

# DXS1V

10/15/20 M TRIBAND ANTENNA

IN “V-SHAPED”

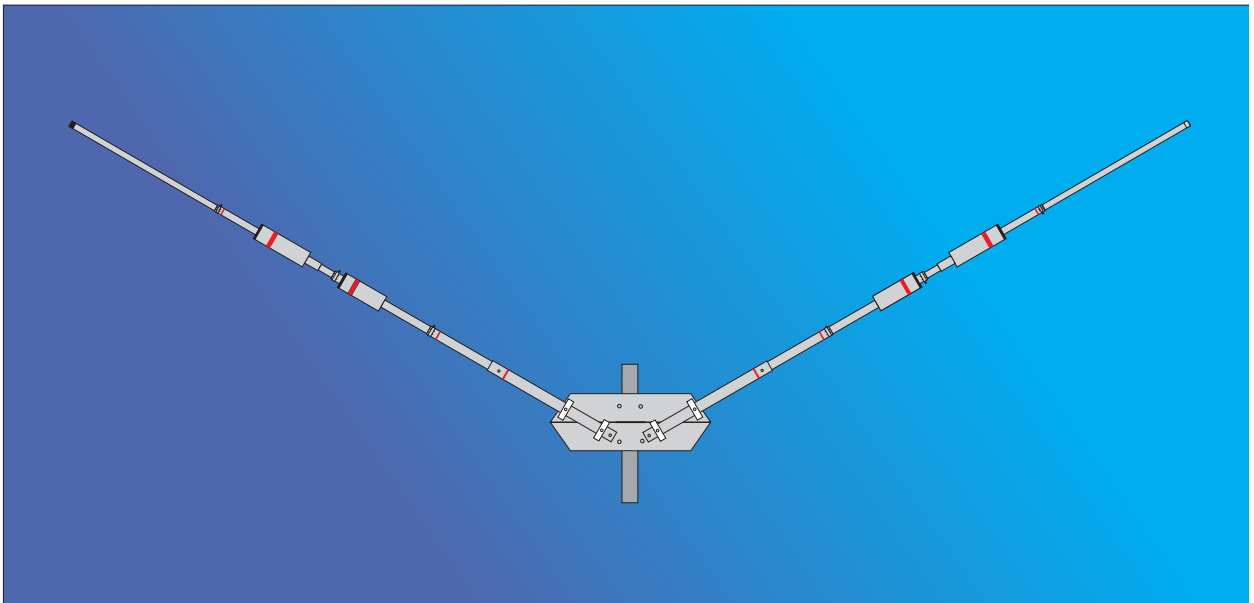

Thank you for purchasing our products. Be sure to read the manual, it is important to better understand the product to make the most of it.

## ASSEMBLY AND INSTALLATION INSTRUCTIONS

### 1. GENERAL INFORMATION

DIEX manufactures a range of antennas designed and produced to give top performance and reliable long lasting service. They are completely manufactured of non-corrosive materials. The antennas come partly factory-assembled in order to facilitate and expedite your labor.

#### 1.1. Introduction and Description

This manual explains how to assemble the DIEX DXS V SERIES. The DXS1V is a V-shaped bidirectional triband antenna covering the 10/15/20m bands. The power limit is 1500w pep.

#### 1.2. Owner Assistance

If assistance or service is needed, your local dealer should be contacted first. In the unlikely event, you need further information you may get in touch with DIEX by email.  
e-mail: diexantennas@gmail.com

#### 1.3. Specifications

MODEL	DXS1V
BAND	10/15/20 M
GAIN	2,4 DBI
2:1 SWR BANDWIDTH	+ 500khz (10/20M) +180khz (15m)
MAX. INPUT PWR	1500 W PEP
>ELEMENT/MINIMUM SPACE	780cm / 687 cm
TURNING RADIUS	345 cm
MAST DIAMETER	1 ¼" TO 2"
WIND-LOAD AREA	0,20 m <sup>2</sup>
WEIGHT	4,2 Kg

#### 1.4. SAFETY FIRST!

Get acquainted with and observe strictly the requirements and instructions of your local legislation. Direct grounding of the antenna and the tower structure is essential as protection from lightning strikes and static electricity. The entire earth-connection system must meet your local standard requirements.

Do not install the antenna close to power lines and cables, as their proximity, arc-over or contact with them during assembly, installation, and exploitation is hazardous and can be lethal.

Do not work alone! You must have at least one assistant always when you work on the antenna. If you have any doubt concerning the safety, please consult your dealer or engage a professional company.

#### 1.5. Location

The antenna should be mounted on a support tower structure at a height between 10 and 15 meters (33-50ft) above the ground level. It must be located in the clear, away from trees, power installations, buildings, other antennas etc. Such objects can be dangerous and they can reduce the antenna efficiency or cause interference. If metal guy wires are used for the tower, they should be broken electrically with strain insulators, at 2 meters (6 ft) apart or less.

#### 1.6. Your first steps

The first step to installation is to fully read this manual. Then, carefully inspect the shipping cartons for any physical damage. DIEX ships antennas in highly protected containers, but it cannot assure that mistreatment by shippers will not occur. If there is any such damage, notify your DIEX dealer immediately.

Failure to do so may invalidate your warranty.  
 Select a large and clear area to assemble the antenna.  
 The DIEX production uses metric (European) system of measurement units.

2. Assembly the DXS1 following the instructions as per the diagrams and illustrations, make the alignment, connect the coaxial, measurements and adjustments and finally attach to the mast.

**LIST OF COMPONENTS AND PARTS BY SECTION**

**DRIVE – (RED) Leave with 10cm of space between the elements.**

ITEM	DESCRIPTION	QTY
1	ALUMINUM PIPES 1 1/8" 1ª SECTION	02
2	ALUMINUM PIPES 1" 2ª SECTION	02
3	1ª TRAP (28 cm)	02
4	2ª TRAP (30,5 cm)	02
5	ALUMINUM PIPES 3/4" (FINAL)	02
SPV	DRIVE SUPPORT "V"	01
TB	INSULATOR PEAD	04
GU1	"V" BOLT WITH SUPPORT	02
A1	CLAMP	04
A2/A3	CLAMP	06
EC	RUBBER COVER 3/4"	02

**2. 1 ASSEMBLING**

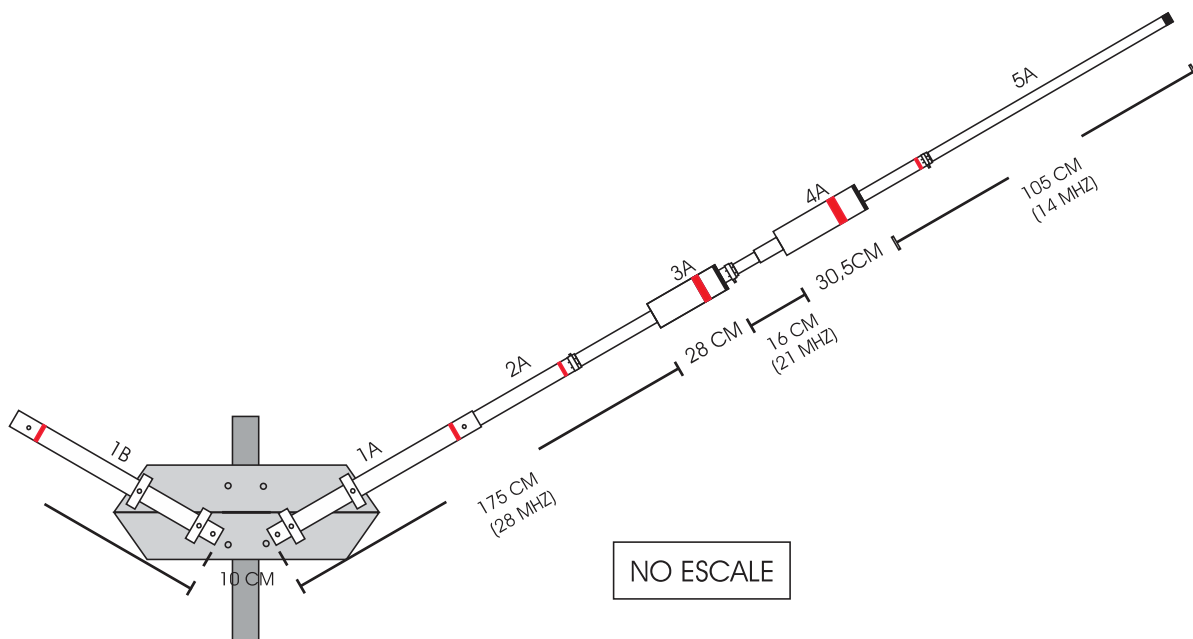

2.2- Installing insulators (IS) on the support (SP).

2.2.1 - Fix the screws (PS) inside the support (SP) in insulators (IS) that should be as Figure 1.

Figure 1



Figure 2

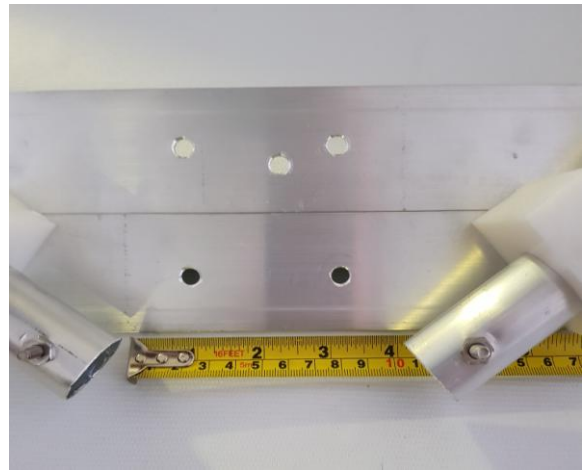

2.3 - Fixing elements in insulators.

2.3.1 - Enter the element (1) in insulators and lock with screws (PS) at the top of the insulators.

2.3.2 - Leave a space of 10cm between the elements 1A and 1B.

2.3.3 - Place the contact screws (PC) as shown in figure 2.

Figure 2.1

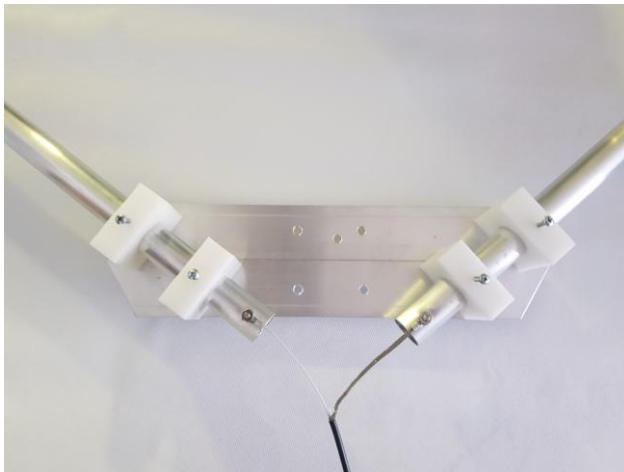
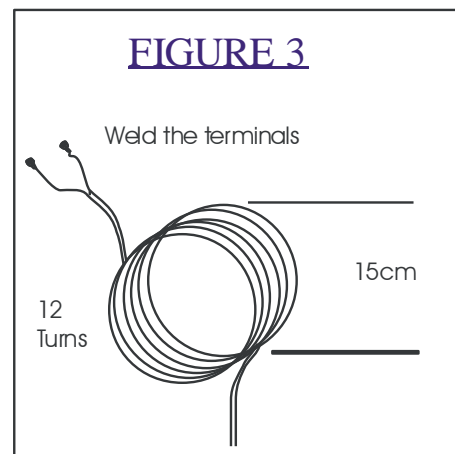

Figure 3



2.3.4 - Connecting the coaxial cable to the antenna Figure 2.1.

The cable connection is open type, see the shock detail in figure 3, it can be done with the coaxial cable itself, strip 10 cm and separate the wires, solder the terminals and leave only 20 cm of space until the start of the shock, they are 12 turns in a diameter of 15cm, use a form for the turns to be well made and parallel, DO NOT use cell cables as the dielectric is made of foam and can deform when making the turns, thus altering the impedance, impairing the functioning.

2.4 - Finishing the installation.

2.4.1 - Place the clip V in support as Figure 4/5 and install in mast in Maximum 2", attach the cable to the mast leaving off to avoid traction on the terminals.

Figures 4

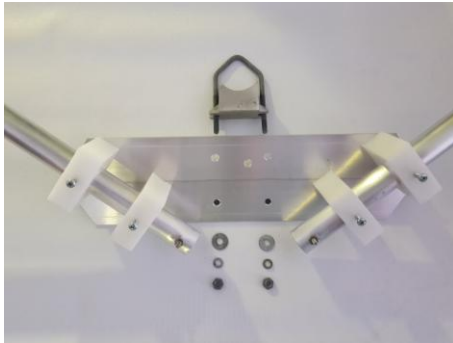
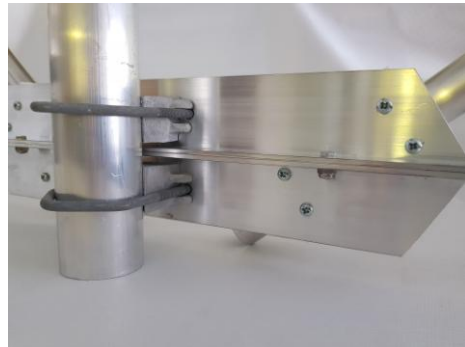

Figure 5



2.4.2 - Perform the installation of the highest antenna possible and free of obstacles, other antennas, walls, etc. For optimum performance and good SWR install 10m height of the base of the antenna or at least 5.50m.

### 3 - Adjusting SWR

3.1 - With the antenna mounted and installed in the correct place, check SWR.

3.2 - If there is a need for adjustments, make small adjustments to the element in 1 band at a time, starting at 10m and then at 15 and 20m increasing if you want to lower the resonance frequency or decreasing if you want to up the resonance frequency, as the adjustment of one band can interfere with the adjustment of another band, always mark what you are doing and then put the same measurement on the other side of the antenna.

3.2.1 - Use a good meter that is reliable. Stay away from the antenna during measurements as your body can cause an erroneous reading. A SWR of 2:1 or less is satisfactory and will not decrease efficiency, if greater than 2:1, do a general check on measurements, position of traps and connections.

3.2.2-The SWR verification must be done in the definitive place, where the antenna must be installed. Measurements with the antenna close to the ground are wrong and will not hold up when raising the antenna.

3.2.3-The ideal height for installation is  $\frac{1}{2}$  wave from the ground or buildings, if you do not have this possibility, use  $\frac{1}{4}$  wave or at least  $\frac{1}{8}$  wave, however the efficiency and bandwidth can be changed.

3.2.4-Remember, bigger antenna, lower frequency or smaller antenna, higher frequency.

3.2.5-Find the resonance point on the antenna (smallest SWR) and use this reminder to see if you need to raise or lower the antenna to get the frequency you want as the center.

3.3-Raise the antenna and, if necessary, repeat the operations, the time invested in the adjustments returns in quality of operation.

The contents of this manual are subject to change without notice.

### **WARRANTY**

Diex antenna products are guaranteed for One year against manufacturing defects, Diex may repair or replace parts or all of the product at its own discretion within the warranty period. Damage caused by lightning, falling, forces of nature, misuse, installation by an unqualified person, i.e., improper, negligent or incorrect assembly is not covered by the warranty. Products that undergo any adaptation or alteration or repairs by unauthorized service automatically void the warranty.

Manual DXS1V fe

Rua Almirante Lobo 310 – Ipiranga – São Paulo – SP – Brazil

TELEPHONE: +55-11-9-7616-9780 –Whatsapp/Telegram – E-mail: diexantennas@gmail.com.br