

Series 16 – Open Circuit Board Controls

- ▶ Solid State Reliability
- ▶ Spade Terminals
- ▶ Time Delays Available
- ▶ U.L. “Motor Control”
- ▶ Optional Dirty Electrode Detection*
- ▶ AC Current Minimizes Electrolysis
- ▶ Compact Size
- ▶ Low-Voltage Sensor
- ▶ LED Monitoring

Series 16 – General Purpose Control

- New Microprocessor Design

Engineered for general purpose single-level or differential applications, these economy priced controls have spade terminals for easy wiring and provide sensitivities up to 1 million ohm/cm.

Series 16D – DPDT Load Contacts

Same features and specifications as Series 16, but these controls also have DPDT load contacts to eliminate the need for slave relays.

Specifications

Contact Design	
Series 16	1 N.O. & 1 N.C. (1 form C)*
Series 16D	2 N.O. & 2 N.C. (2 form C)
Contact Rating (120, 240 VAC)	
Series 16	10 amp Resistive 1/3 hp*
Series 16D	5 amp Resistive 1/10 hp
Mode of Operation	Direct/Inverse, factory set
Sensitivity	0-1M ohm, factory set
Primary Voltage	120 VAC, 240 VAC, 24 VAC, 208 VAC (+10%/-15%) 50/60 Hz 208/240: 187 V min. to 255 V max. VAC 50/60 Hz
Secondary Voltage	12 VAC, 1.5 mA
Temperature	-40°F to +150°F (-40°C to +65°C)
Approvals	U.L. 508 File # E44426
Terminal Style	Spade connection
Options	Time Delays, Retrofit Plate, Time Out. See page E-11 for descriptions.

How to Order

Use the **Bold** characters from the chart below to construct a product code.

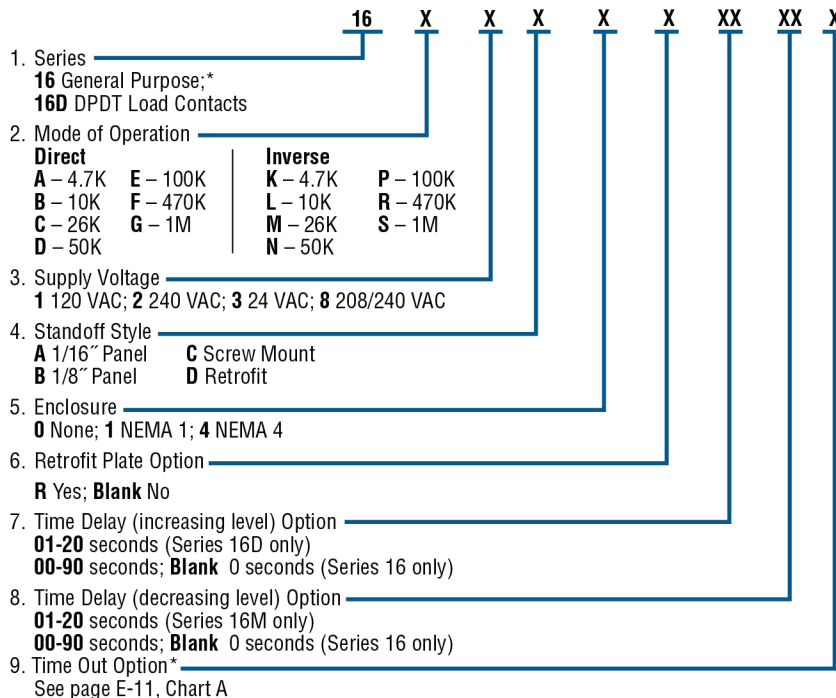

* New Series 16 Microprocessor Design only.



Series 16

Applications

- Single-Level Service
- Point Level
- Valve Control
- Low-Water Cutoff
- Differential Service
- Alarms
- Pump Control

Dimensions

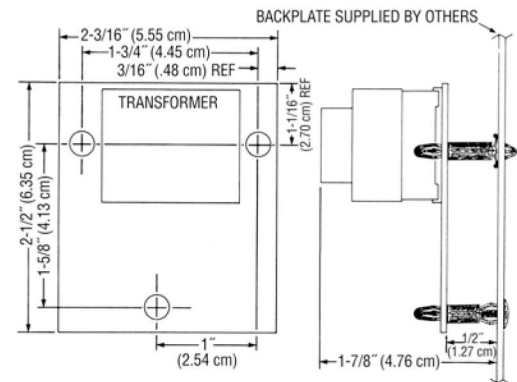

Wiring

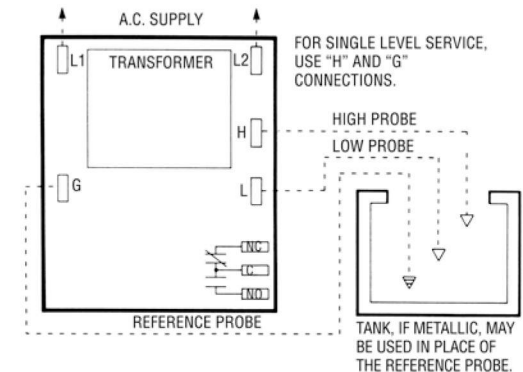

Note: Series 16D similar to Series 16, but with DPDT load contacts.