

## Single-stage safety solenoid valves

MVD, MVD/5,  
MVDLE/5

**DUNGS®**



### Technical description

The DUNGS safety solenoid valve MVD, MVD/5, MVDLE/5 is a single-stage automatic shut-off valve as per EN 161 for gas burners and gas appliances.

- Max. operating pressure up to 200, 360 or 500 mbar
- normally closed
- MVD: fast opening
- MVDLE: Slow opening with adjustable fast stroke for start gas volume
- Main volume adjustable (MVD/MVDLE)
- DC solenoid, rectifier wiring with radio interference suppression in terminal box with PG screw union
- Mountable closed position signal contact to monitor closed position of valve (.../5)
- Pipe thread as per ISO 7/1
- Flange connection as per DIN 2633, ISO 7005
- Reliable function, rugged and maintenance-free

- On request, design without non-ferrous metals

### Application

The solenoid valve is used for securing, limiting, shutting off and releasing gas supply to gas burners and gas appliances.

The DUNGS safety solenoid valve MV... is suitable for gases of families 1, 2, 3 and other neutral gaseous media.

### Approval

EU type test approval as per EU Gas Appliance Directive.

Approvals in other important gas-consuming countries.

Special designs for the North American market with U<sub>L</sub>, FM and CSA registrations.

<b>MV/5</b>	Single-stage solenoid valve, normally when closed, fast opening, fast closing.
<b>MVD/5</b>	Single-stage solenoid valve, normally when closed, fast opening, fast closing, manual limitation of flowing gas volume by adjusting main volume.
<b>MVDLE/5</b>	One-stage solenoid valve, normally when closed, slow opening, fast closing. Opening time adjustment with fast stroke range. Main volume adjustment.

## Specifications

Nominal diameters	10 15 20 25 40 50 65 80 100 125 150 200
Pipe thread as per ISO 7/1, Rp	3/8 1/2 3/4 1 1 1/2 2 2 1/2
Flange	Connection flange as per DIN 2501 Part 1, to fit preweld flanges as per DIN 2633 (PN 16) DN 20 to DN 200, ISO 7005 - 1 (PN 16), ISO 7005 - 2 (PN 16)
Max. operating pressure	up to 200 mbar (20 kPa), 360 mbar (36 kPa) or up to 500 (50 kPa) mbar - refer to type overview
Solenoid valve	Valve as per EN 161, Class A, Group 2, single-stage mode
Pressure stage	PN 1
Closing time	< 1 s
Opening time	< 1 s for MVDLE approx. 20 s at room temperature 20°C and without fast stroke
Fast stroke	Adjustable
Main volume adjustment	Manually adjustable on MVD and MVDLE
Materials of gas-conveying parts	Housing: aluminium, steel, brass Seals: NBR basis
Voltage/frequency	230 V AC (+10 % -15 %); 50-60 Hz - other voltages on request Refer to
Rating / power consumption	type overview
Switch-on duration	100 %
Degree of protection Electrical	IP 54, IP 65 on request
connection	At screw terminals via PG* 11 cable gland (* = heavy-gauge conduit thread) Plug connection as per DIN 43650 can be retrofitted
Switching rate	MVD.../5: max. 1000/h MVD 2200, MVDLE.../5: max. 100/h MV 5100/5 S, MV 2125/5 S, MV 2150/5 S: max. 20/h
Measuring/ignition gas connection	G 1/4 ISO 118, on both sides in inlet section, additionally G 3/4 on input side, form size DN 40 (flange) upwards
Dirt trap	Sieve installed, mesh width 1 mm
Ambient temperature	-15 °C to + 60 °C
Installation position	Solenoid from vertically upright to horizontally lying
Closed position signal contact Valve	Type K01/1, DIN-tested, mountable on DN 10 - DN 150
proving system	Type VDK 200 A S02, mountable via G 1/4 test connection, Type VPS 504, mountable with adapter up to DN 80
Accessories	K01 closed position signal contact, see Datasheet 12.01 211 202 Equipment plug for line socket, DIN 43650 215 733

Type	p <sub>max.</sub>	DN / Rp	Sole-	Order No.	P <sub>max.</sub>	I <sub>max.</sub>	Opening	Dimensions [mm]						Weight
			noid No.		[VA]	~ (AC) 230 V	time	ø a	b	c	d	e	f	[kg]
MVD 203/5	360	Rp 3/8	100	108 571	15	0.08	< 1 s	50	60	90	75	155	190	0.85
MVD 205/5	360	Rp 1/2	100	013 102	15	0.08	< 1 s	50	75	135	75	113	200	1.00
MVD 207/5	200	Rp 3/4	150	013 227	32	0.13	< 1 s	60	100	135	80	160	190	1.75
MVD 207/5	360	Rp 3/4	200	121 962	25	0.15	< 1 s	75	100	135	80	160	190	2.4
MVD 210/5	360	Rp 1	200	013 490	25	0.15	< 1 s	75	110	135	90	165	190	2.45
MVD 215/5	200	Rp 1 1/2	280	015 446	60	0.26	< 1 s	80	150	170	116	210	255	4.3
MVD 215/5	360	Rp 1 1/2	300	129 977	60	0.30	< 1 s	95	150	170	116	210	255	5.4
MVD 220/5	200	Rp 2	300	011 767	60	0.30	< 1 s	95	170	175	130	220	255	5.90
MVD 225/5	200	Rp 2 1/2	400	119 701	90	0.48	< 1 s	115	230	215	165	270	325	10.90
MVDLE 203/5	360	Rp 3/8	100	108 597	15	0.08	approx. 20 s	50	60	135	75	155	190	0.95
MVDLE 205/5	360	Rp 1/2	100	013 284	15	0.08	approx. 20 s	50	75	135	75	155	200	1.10
MVDLE 207/7	360	Rp 3/4	200	013 276	25	0.15	approx. 20 s	75	100	165	80	190	190	2.55
MVDLE 210/5	360	Rp 1	200	013 524	25	0.13	approx. 20 s	75	110	165	90	195	190	2.75
MVDLE 215/5	200	Rp 1 1/2	280	015 412	60	0.26	approx. 20 s	80	150	205	116	245	255	4.4
MVDLE 215/5	360	Rp 1 1/2	300	122 002	60	0.30	approx. 20 s	95	150	205	116	245	255	5.5
MVDLE 220/5	200	Rp 2	300	011 775	60	0.26	approx. 20 s	95	170	205	130	250	255	6.20
MVDLE 225/5	200	Rp 2 1/2	400	118 935	90	0.48	approx. 20 s	115	230	295	165	350	320	11.40
MVD 503/5	500	Rp 3/8	100	158 090	15	0.08	< 1 s	50	60	90	75	155	190	0.85
MVD 505/5	500	Rp 1/2	100	158 110	15	0.08	< 1 s	50	75	90	75	113	200	1.00
MVD 507/5	500	Rp 3/4	200	157 530	25	0.15	< 1 s	75	100	135	80	160	190	2.40
MVD 510/5	500	Rp 1	200	157 540	25	0.15	< 1 s	75	110	135	90	165	190	2.60
MVD 515/5	500	Rp 1 1/2	300	157 550	60	0.30	< 1 s	95	150	175	116	210	255	5.40
MVD 520/5	500	Rp 2	400	167 200	90	0.48	< 1 s	115	170	190	130	235	300	8.80
MVD 525/5	500	Rp 2 1/2	500	170 750	80	0.42	< 1 s	130	230	215	165	270	370	14.50
MVDLE 503/5	500	Rp 3/8	100	222 077	15	0.08	approx. 20 s	50	60	135	75	155	190	0.80
MVDLE 505/5	500	Rp 1/2	120	222 078	24	0.11	approx. 20 s	50	75	150	75	170	220	1.00
MVDLE 507/5	500	Rp 3/4	200	222 079	25	0.15	approx. 20 s	75	100	165	80	190	190	1.70
MVDLE 510/5	500	Rp 1	250	222 080	30	0.12	approx. 20 s	75	110	190	90	220	213	2.60
MVDLE 515/5	500	Rp 1 1/2	300	222 801	60	0.30	approx. 20 s	95	150	205	116	245	255	5.6
MVDLE 520/5	500	Rp 2	400	222 082	90	0.48	approx. 20 s	115	170	225	130	270	300	11.10
MVD 2020/5	200	DN 20	150	110 841	32	0.13	< 1 s	60	150	135	105	160	190	2.3
MVD 2020/5	360	DN 20	200	on request	25	0.15	< 1 s	75	150	135	105	160	190	2.9
MVD 2025/5	360	DN 25	200	110 882	25	0.13	< 1 s	75	160	165	115	195	190	3.50
MVD 2040/5	200	DN 40	280	111 146	60	0.26	< 1 s	80	200	170	150	210	255	6.8
MVD 2040/5	360	DN 40	300	119 906	60	0.30	< 1 s	95	200	170	150	210	255	7.0
MVD 2050/5	200	DN 50	300	111 187	50	0.26	< 1 s	95	230	175	165	230	255	7.70
MVD 2065/5	200	DN 65	400	169 390	90	0.48	< 1 s	115	290	215	185	275	320	12.70
MVD 2080/5	200	DN 80	500	169 400	80	0.42	< 1 s	130	310	250	200	305	360	26.50
MVD 2100/5	200	DN 100	550	169 410	90	0.48	< 1 s	150	350	310	240	395	480	31.00
MVDLE 2020/5	360	DN 20	200	110 858	25	0.13	approx. 20 s	75	150	165	105	190	190	3.50
MVDLE 2025/5	360	DN 25	200	110 890	25	0.13	approx. 20 s	75	160	165	115	195	190	4.00
MVDLE 2040/5	200	DN 40	280	119 914	60	0.26	approx. 20 s	80	200	205	150	245	255	6.9
MVDLE 2040/5	360	DN 40	300	111 153	80	0.30	approx. 20 s	95	200	205	150	245	255	7.1
MVDLE 2050/5	200	DN 50	300	111 195	60	0.26	approx. 20 s	95	230	205	165	250	255	7.50
MVDLE 2065/5	200	DN 65	400	170 930	90	0.48	approx. 20 s	115	290	295	185	350	320	13.30
MVDLE 2080/5	200	DN 80	500	170 940	80	0.42	approx. 20 s	130	310	320	200	390	360	26.50
MVDLE 2100/5	200	DN 100	550	170 950	90	0.48	approx. 20 s	150	350	385	240	470	465	31.00
MVD 5020/5	500	DN 20	200	170 600	25	0.13	< 1 s	75	150	135	105	160	190	3.50
MVD 5025/5	500	DN 25	200	170 630	25	0.13	< 1 s	75	160	135	115	165	190	4.00
MVD 5040/5	500	DN 40	300	170 660	60	0.26	< 1 s	95	200	170	150	230	255	7.00
MVD 5050/5	500	DN 50	400	170 690	90	0.48	< 1 s	115	230	190	165	235	300	12.00
MVD 5065/5	500	DN 65	500	165 510	80	0.42	< 1 s	130	290	235	185	295	370	17.00
MVD 5080/5	500	DN 80	550	165 640	90	0.50	< 1 s	150	310	290	200	360	465	32.00
MVD 5100/5	500	DN 100	60E	166 150	90	7.5*	< 1 s	170	350	360	240	418	600	42.00
MVDLE 5020/5	500	DN 20	200	222 084	25	0.13	ca. 20 s	75	150	165	80	190	190	3.50
MVDLE 5025/5	500	DN 25	250	222 085	30	0.12	ca. 20 s	75	160	190	90	220	213	3.90

**Dimensions [mm] MVD**  
**203 - 525/5, MVDLE**  
**2020/5 - 5100/5**

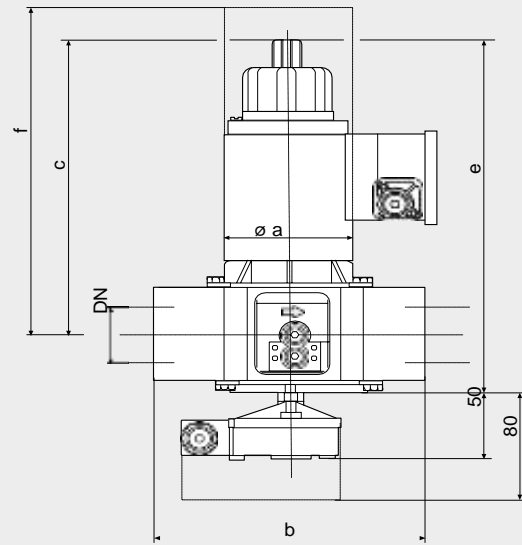
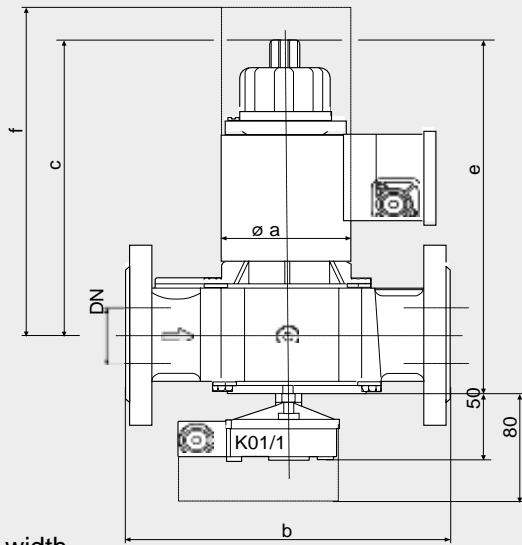

d = largest width  
 K01/1 closed position indicator

**Dimensions [mm]**  
**MV 5100/5 S - MVD 2200**

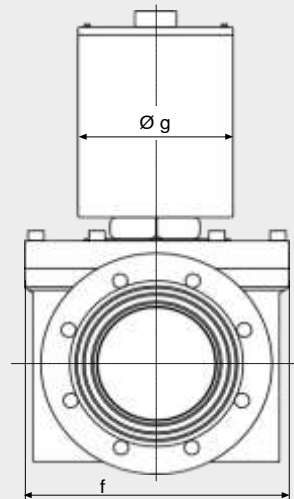
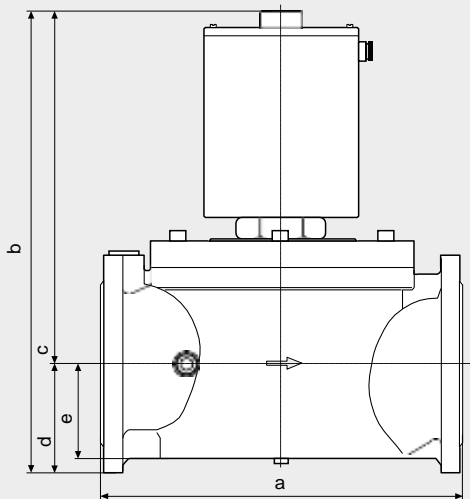

Type	P <sub>max.</sub>	DN / Rp	Order No.	Sole- noid No.	P <sub>max.</sub> [VA]*	I <sub>max.</sub> ~(AC) time 230 V [A]**	Opening Dimensions[mm]							Weight [kg]	
							a	b	c	d	e	f	g		
<b>MV 5100/5 S</b>	500	DN 100	220 754	60S	90	7.5	< 1 s	350	465	365	240	80	100	170	39.0
<b>MV 2125/5 S</b>	200	DN 125	224 681	60S	90	10	< 1 s	400	531	406	290	112	125	170	56.0
<b>MV 2150/5 S</b>	200	DN 150	224 682	61S	90	10	< 1 s	480	582	439	290	125	143	170	62.0
<b>MVD 5100/5</b>	500	DN 100	166 150	60E	90	7.5	< 1 s	350	465	365	240	80	100	170	39.0
<b>MVD 5125/5</b>	500	DN 125	159 840	61E	90	10	< 1 s	400	531	406	290	112	125	170	56.0
<b>MVD 5150/5</b>	500	DN 150	160 350	61E	90	10	< 1 s	480	582	439	290	125	143	170	62.0
<b>MVD 2200</b>	200	DN 200	213 892	70E	90	10	< 1 s	600	760	590	415	160	170	214	123.0

\* Electrical rating in open state  
 \*\* Switch-on current for approx. 3 s

## Type MVD.../5

## Type MVDLE/5

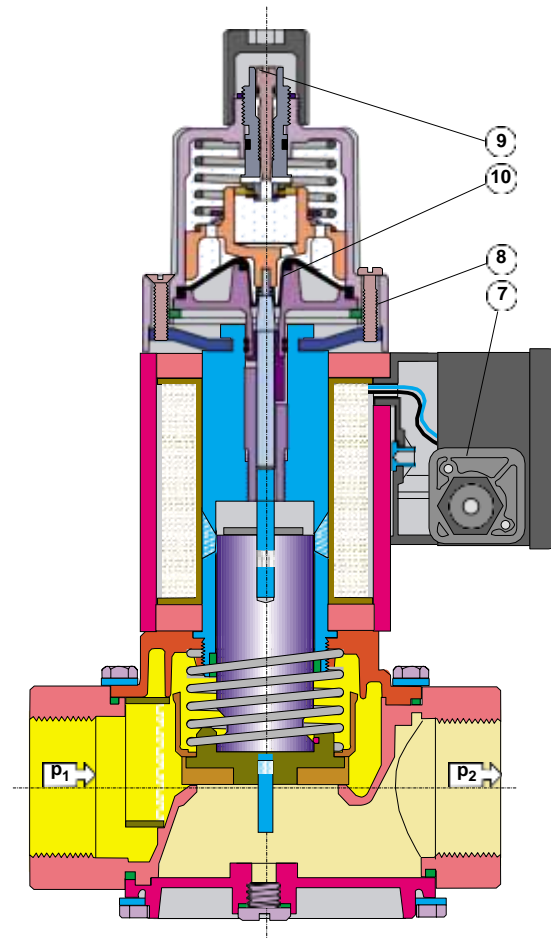
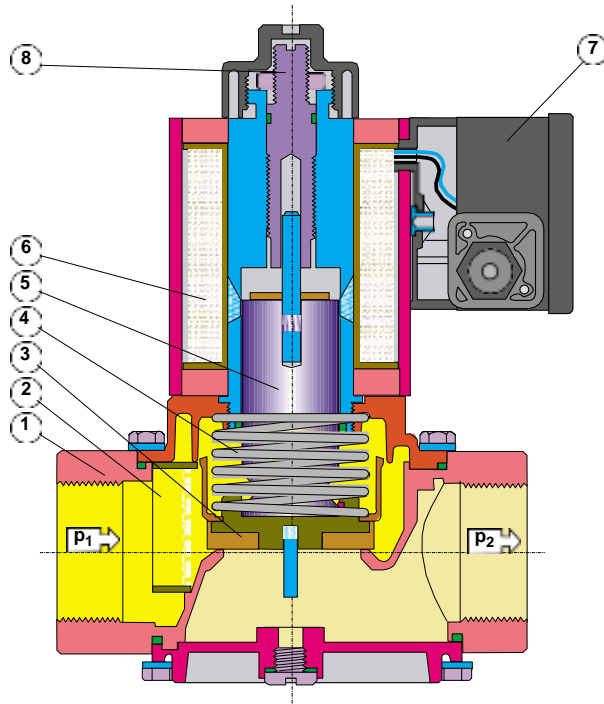

- 1 Housing
- 2 Sieve
- 3 Valve plate
- 4 Closing spring

- 5 Armature
- 6 Solenoid coil
- 7 Electrical connection

- Setting
- 8 - Main volume
- 9 - Fast stroke
- 10 - Hydraulic brake

### Functional description

The DUNGS safety solenoid valve is an automatic shut-off valve operated with auxiliary power. The electromagnetic drive opens against the force of the closing spring

4. The stroke of armature 5 can be limited by the setting screw 8. The hydraulic brake 10 permits slow opening. Fast stroke 9 can be adjusted.

If the auxiliary power is interrupted (operating voltage), closing spring 4 closes the valve within 1 second. The closed position of the valve can be monitored by a mountable closed position signal contact.

$$\dot{V}_{\text{verwendetes Gas/gas used/ gaz utilisé/gas utilizzato}} = V_{\text{Luft/air/air/aria}}^{\circ} \times f$$

f =

$$f = \sqrt{\frac{\text{Dichte des verwendeten Gases}}{\text{Dichte Luft}}}$$

Spec. weight of gas used / poids spécifique du gaz utilisé / peso específico del gas utilizado

Spec. weight air / poids spécifique de l'air / peso específico aria

Gasart  
Type of gas  
Type de gaz  
Tipo di gas

Dichte  
Spec. Wgt.  
poids spécifique  
Peso específico  
[kg/m<sup>3</sup>]

dv

f

Erdgas/Nat. Gas/  
Gaz naturel/Gas metano

0.81

0.65

1.24

Stadtgas/City gas/  
Gaz de ville/Gas città

0.58

0.47

1.46

Flüssiggas/LPG/  
Gaz liquide/Gas liquido

2.08

1.67

0.77

Luft/Air/  
Air/Aria

1.24

1.00

1.00

Single-stage safety  
solenoid valves  
MVD, MVD/5,  
MVDLE/5

DUNGS®

Flow diagram

