



MODEL AFS-A

APPLICATION

Model AFS-A is a general purpose airflow proving switch typically applied to package burners, furnaces, and fuel-burning equipment. AFS-A accurately senses positive, negative, or differential air pressure.

DESCRIPTION & OPERATION

The plated housing contains a diaphragm, a calibration spring and a snap-acting SPDT switch.

An enclosure cover guards against accidental contact with the live switch terminal screws and the set point adjusting screw. The enclosure cover accepts a 1/2" conduit connection.

MOUNTING (SEE FIGURE 1)

Select a mounting location that is free from vibration. The AFS-A must be mounted with the diaphragm in any vertical plane in order to obtain the lowest specified operating set point. Do not mount with the sample line connections in the "up" position.

Surface-mount the switch to a flange via the 1" -14 externally threaded connector with pal nut. This connector is also internally threaded (1/4" - 18 NPT) for rigid mounting to a pipe nipple.

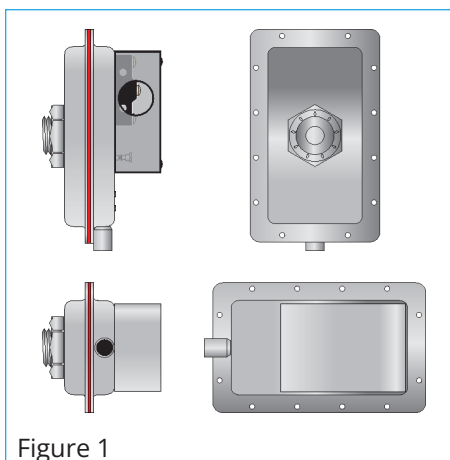

Figure 1



AIR SAMPLING CONNECTION (SEE FIGURE 2)

Refer to Figure 2 to identify the high pressure inlet (H) and the low pressure inlet (L). AFS-A is equipped with a 1/4" - 18 NPT female connector ("H") and a 1/8" - 27 NPT female connector ("L"). The sample connection located on the low pressure side of the diaphragm accepts 1/8" pipe. The sample connection located on the high pressure side of the diaphragm accepts 1/4" pipe.

For sample lines of up to 10 feet, 1/8" pipe is acceptable. For lines up to 20 feet, use 1/4" pipe. For lines up to 60 feet, use 1/2" pipe. For each right angle bend, add 4 feet to the computed sample line length to determine correct pipe size.

Locate the sampling probe a minimum of 1-1/2 duct diameters downstream from the air source. Install the sam-

pling probe as close to the center of the airstream as possible.

Select one of the five application options listed below, and connect the sample lines as recommended.

POSITIVE PRESSURE ONLY: Connect the sample line to inlet H; inlet L remains open to the atmosphere.

NEGATIVE PRESSURE ONLY: Connect the sample line to inlet L; inlet H remains open to the atmosphere.

TWO NEGATIVE SAMPLES: Connect the higher negative sample to inlet L. Connect the lower negative sample to inlet H.

TWO POSITIVE SAMPLES: Connect the higher positive sample to inlet H. Connect the lower positive sample to inlet L.

ONE POSITIVE AND ONE NEGATIVE: Connect the positive sample to inlet H. Connect the negative sample to inlet L.

ELECTRICAL CONNECTIONS

(SEE FIGURES 3 & 4)

Before pressure is applied to the diaphragm, the switch contacts will be in the normally closed (NC) position. The snap switch has screw top terminals with cup washers. Wire alarm and control applications as shown in Figure 4.

FIELD ADJUSTMENT

AFS-A has an adjustment range of 0.05 to 12.0" wc., ± 0.02 " wc. To adjust the set point, turn the adjusting screw counterclockwise until motion has stopped. Next, turn the adjusting screw 4 complete turns clockwise to engage the calibration spring. From this point, the next ten turns will be used for the actual calibration. Each full turn represents approximately 1.2" wc. Please note: To properly calibrate an air switch, a digital manometer or other measuring device should be used to confirm the actual set point.

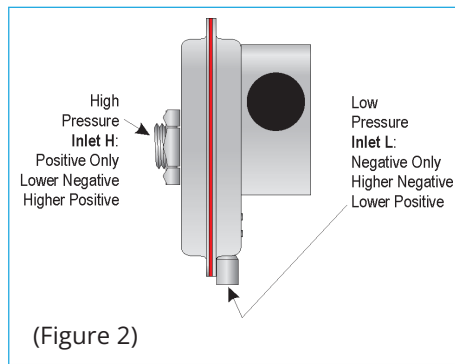

(Figure 2)

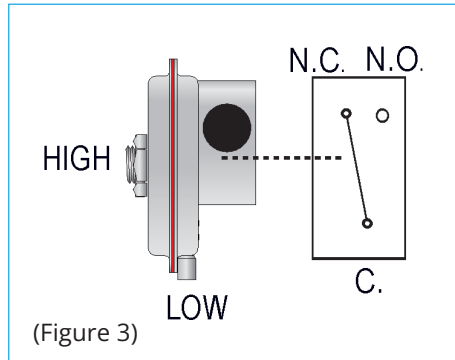

(Figure 3)

To prove excessive air flow or pressure:

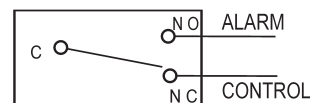

To prove insufficient air flow or pressure:

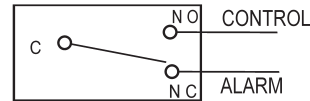

(Figure 4)

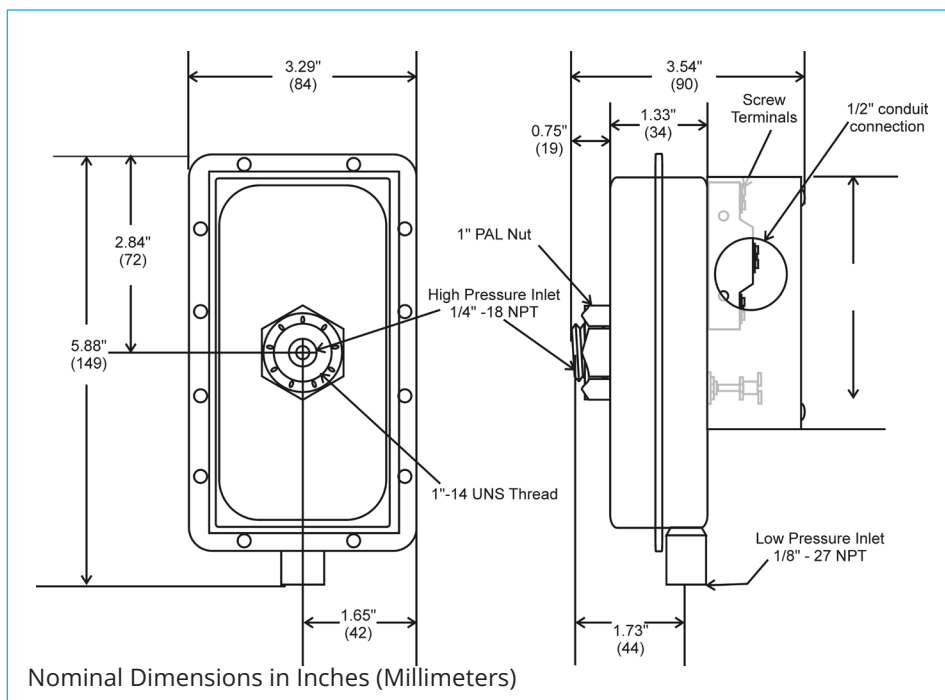

Nominal Dimensions in Inches (Millimeters)

SPECIFICATIONS MODEL AFS-A AIR PRESSURE SENSING SWITCH WITH ADJUSTABLE SET POINT



Mounting Position:

Mount with the diaphragm in any vertical plane.

Set Point Range:

0.05 \pm 0.02" wc to 12.0" wc
(1.27 mm wc to 304.8 mm wc) (0 to 0.43 psi)

Field Adjustable "Operate Range":

0.07" wc to 12.0" wc

Field Adjustable "Release Range":

0.04" wc to 11.2" wc

Approximate Switching Differential:

Progressive, increasing from 0.02 \pm 0.01" wc at minimum set point to approximately 0.8" wc at maximum set point

Measured Media:

Air, or combustion by-products that will not degrade silicone

Maximum Pressure: 1/2 psi (0.03 bar)

Operating Temperature Range:

-40 °F to 180 °F (-40 °C to 82 °C)

Life:

100,000 cycles minimum at 1/2 psi maximum pressure each cycle and at maximum rated electrical load

Electrical Rating:

300 VA pilot duty at 115 to 277 V ac,
15 Amps noninductive to 277 V ac, 60 Hz

Contact Arrangement:

SPDT

Electrical Connections:

Screw-type terminals with cup washers

Conduit Opening:

7/8" diameter opening accepts 1/2" conduit.

Sample Line Connectors:

1/4" - 18 NPT female (high pressure inlet)
1/8" - 27 NPT female (low pressure inlet)

Sample Line Connections:

Connectors accept 1/4" OD rigid or semi-rigid tubing.

Approvals: UL, CSA

Shipping Weight: 1.2 lbs.

Accessories:

- Sample line probes
- Orifice plugs (pulsation dampers)