

FM Starpoint Combiner

13 kW, 2 Pole

BAND II

10 year GUARANTEE

SPECIFICATIONS	200 mm Series	Option
FREQUENCY	87 - 108 MHz	
STANDARD ORDER	2 Poles	with temperature compensation
APPLICATION	FM combining & Spurious supress	
IMPEDANCE	50 Ohm	
NB RETURN LOSS (VSWR)	>26 dB (1.1)	
NB INPUT CONNECTOR	3 1/8" unflange	4 1/2" unflange
OUTPUT CONNECTOR	3 1/8" unflange	4 1/2" unflange
TEMPERATURE STABILITY	≤ 3 kHz / °C (without temp. comp.)	≤ 0.5 kHz / °C (with temp. comp.)
MAX PRODUCT TEMPERATURE	70 °C	
ENVIROMENTAL CONDITION	0 to 70 °C IP40	

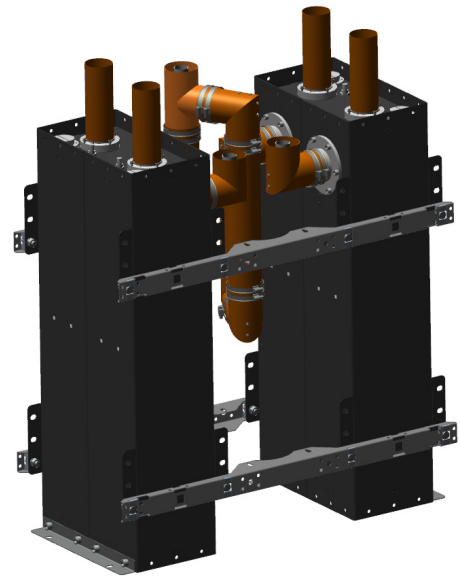

DIMENSIONS AND WEIGHT	
INDICATIVE DIMENSIONS	935 x 439 x 1146 mm
L x W x H	(36.8 x 17.3 x 45.1 in)
STANDARD FRAME	Stand alone
COLOUR	Black and aluminium

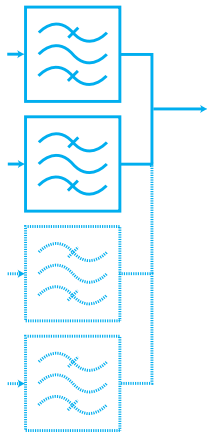

Article structure:
ARTICLE: SP22C20C-0P33-2
SP = Combiner Type
2 = Frequency band
2 = Number of poles
C = Cavity based
20 = Cavity size
C = Version
C = without temp. comp. D = with temp. comp.
0 = Number of cross coupling
0 = without
P = Coating
P = blackpainted
3 = Narrowband connection
3 = 3 1/8" unflange, 4 = 4 1/2" unflange
3 = Output connection
3 = 3 1/8" unflange, 4 = 4 1/2" unflange
2 = Number of inputs

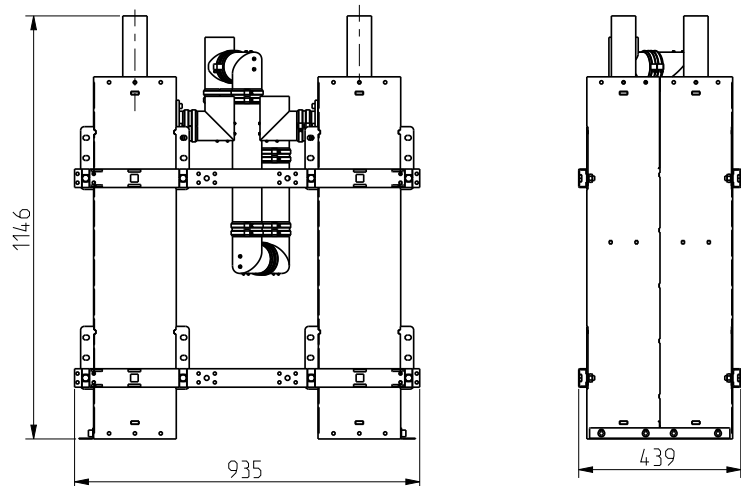

Example of design, may be changed depending on channel allocation and No of inputs.
 Subjected to change without prior notice.

ARTICLE	SP22C20x-0Pxx-2					SP22C20x-0Pxx-3					SP22C20x-0Pxx-4				
NUMER OF INPUTS	2					3					4				
MIN CHANNEL SPACING	6.0 MHz	5.0 MHz	4.0 MHz	3.0 MHz	2.2 MHz	6.0 MHz	5.0 MHz	4.0 MHz	3.0 MHz	2.2 MHz	6.0 MHz	5.0 MHz	4.0 MHz	3.0 MHz	2.2 MHz
MAX INPUT POWER / INPUT	13 kW	10 kW	8.4 kW	6.8 kW	4.9 kW	13 kW	10 kW	8.4 kW	6.8 kW	4.9 kW	13 kW	10 kW	8.4 kW	6.8 kW	4.9 kW
INSERTION LOSS (dB)															
Centre frequency	<0.2	<0.2	<0.2	<0.3	<0.4	<0.2	<0.2	<0.3	<0.3	<0.4	<0.3	<0.3	<0.3	<0.4	<0.5
±150 kHz	<0.2	<0.2	<0.2	<0.3	<0.5	<0.2	<0.2	<0.3	<0.4	<0.5	<0.3	<0.3	<0.3	<0.4	<0.6
ISOLATION BETWEEN INPUTS															
Input frequency spacing															
±2.2 MHz	-	-	-	-	>30 dB	-	-	-	-	>30 dB	-	-	-	-	>30 dB
±3.0 MHz	-	-	-	>30 dB	>35 dB	-	-	-	>30 dB	>35 dB	-	-	-	>30 dB	>35 dB
±4.0 MHz	-	-	>30 dB	>35 dB	>40 dB	-	-	>30 dB	>35 dB	>40 dB	-	-	>30 dB	>35 dB	>40 dB
±5.0 MHz	-	>30 dB	>35 dB	>35 dB	>40 dB	-	>30 dB	>35 dB	>35 dB	>40 dB	-	>30 dB	>35 dB	>35 dB	>40 dB
±6.0 MHz	>30 dB	>35 dB	>35 dB	>40 dB	>45 dB	>30 dB	>35 dB	>35 dB	>40 dB	>45 dB	>30 dB	>35 dB	>35 dB	>40 dB	>45 dB
±8.0 MHz	>35 dB	>40 dB	>40 dB	>45 dB	>50 dB	>35 dB	>40 dB	>40 dB	>45 dB	>50 dB	>35 dB	>40 dB	>40 dB	>45 dB	>50 dB
WEIGHT	60 kg (132.3 lb)					90 kg (198.4 lb)					120 kg (264.6 lb)				

* Data in table is typical data. at 100 MHz. The combiner can be tuned for other specifications or bandwidth. Please contact us for a designed specification.
 ** All average power values and technical data refer to an ambient temperature of +20 °C with normal airflow. The product can have a maximum surface temperature of +70 °C. Maximum power capacity may be lower depending on channel allocation. Data are subjected to change without prior notice.