



# UHF Constant Impedance Combiner

5 kW rms, 6 Pole, Compact



SPECIFICATIONS	140 mm Compact Series
FREQUENCY	470 - 862 MHz
BANDWIDTH	6 - 8 MHz
STANDARD ORDER	6 Poles single cross coupling
OPTIONAL ORDER	6 Poles with or without double cross coupling
APPLICATION	Adjacent Ch combining
ATV	Spurious suppress
DVB	Non critical mask
ATSC	Stringent mask
ISDB	Non critical mask
IMPEDANCE	50 Ohm
NB RETURN LOSS (VSWR)	>26 dB (<1.11)
WB RETURN LOSS (VSWR)	>26 dB (<1.11), UHF band >30 dB (<1.07), 2 specified channels
MAX OUTPUT POWER RATING**	5 kW rms 1 5/8" (coupler type G) 15 kW rms 3 1/8" (coupler type J)
NB INPUT CONNECTOR	1 5/8" unflange
WB STANDARD INPUT CONNECTOR	3 1/8" unflange (coupler type J)
WB OPTIONAL INPUT CONNECTORS	1 5/8" unflange (coupler type G)
STANDARD OUTPUT CONNECTOR	3 1/8" unflange (coupler type J)
OPTIONAL OUTPUT CONNECTORS	1 5/8" unflange (coupler type G)
TEMPERATURE STABILITY	< 2 kHz / °C
MAX PRODUCT TEMPERATURE	70 °C
ENVIROMENTAL CONDITION	-5 to 70 °C IP40

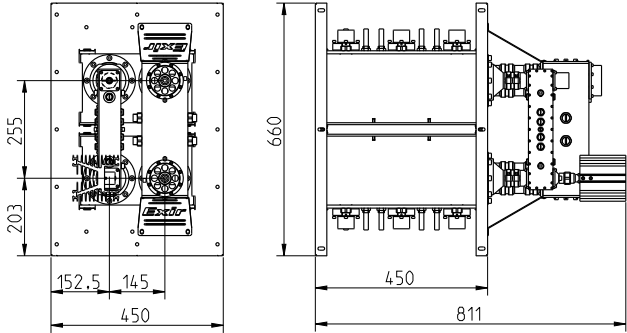

DIMENSIONS AND WEIGHT	
DIMENSIONS	811 x 450 x 660 mm
L x W x H	(31.9 x 17.7 x 26.0 in)
WEIGHT	90 kg (198.4 lb)
STANDARD FRAME	Stand alone / 19"
COLOUR	Black and aluminium

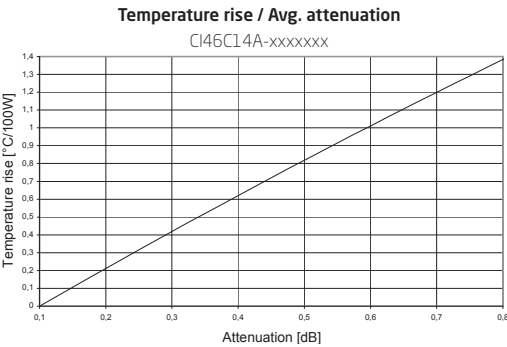
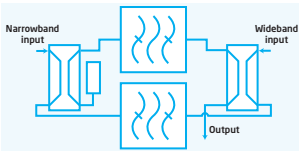

**Article structure:**  
**ARTICLE: CI46C14A-1PGJ133**

- CI** = Combiner Type
- 4** = Frequency band
- 6** = Number of poles
- C** = Cavity based
- 14** = Cavity size
- A** = Version
- 1** = Number of cross coupling  
0 = without, 1 = single, 2 = double
- P** = Coating  
0 = without, P = painted, N = painted & silver plated
- G** = Narrowband coupler  
G = 54mm
- J** = Wideband coupler  
G = 54mm, J = 110mm
- 1** = Narrowband connection  
1 = 1 5/8" unflange, 7 = 7/8" unflange
- 3** = Wideband connection  
1 = 1 5/8" unflange, 3 = 3 1/8" unflange
- 3** = Output connection  
1 = 1 5/8" unflange, 3 = 3 1/8" unflange

TYPICAL DATA*	8 MHz DVB-T/2	6 MHz ISDB-T	6 MHz ATSC
ARTICLE NO	CI46C14A-1Pxxxxx	CI46C14A-1Pxxxxx	CI46C14A-1Pxxxxx
<b>NB INSERTION LOSS</b>			
Avg. signal bandwidth	<0.49 dB	<0.59 dB	<0.57 dB
Centre frequency	<0.40 dB	<0.52 dB	<0.53 dB
Signal band edge	± 3.88 MHz <1.25 dB (3,8 MHz 0,99 dB)	± 2.79 MHz <0.85 dB	± 2.69 MHz <0.70 dB
	± 4.2 MHz >5 dB	± 3.15 MHz >1.30 dB	± 3.5 MHz >1.50 dB
	± 6.0 MHz >16 dB	± 4.5 MHz >17 dB	± 6.0 MHz >29 dB
	± 12.0 MHz >41 dB	± 9.0 MHz >47 dB	± 9.0 MHz >63 dB
<b>WB INSERTION LOSS</b>			
	± 24 MHz <0.10 dB	± 18 MHz <0.10 dB	± 18 MHz <0.10 dB
	± 16 MHz <0.10 dB	± 12 MHz <0.10 dB	± 12 MHz <0.10 dB
	± 8.0 MHz <0.20 dB	± 6 MHz <0.20 dB	± 6 MHz <0.20 dB
<b>ISOLATION</b>			
NARROWBAND - WIDEBAND	>36 dB	>36 dB	>36 dB
WIDEBAND - NARROWBAND @			
	± 4.2 MHz >36 dB	± 3.21 MHz >36 dB	± 3.31 MHz >36 dB
	± 8.0 MHz >60 dB	± 6 MHz >65 dB	± 6 MHz >75 dB
	± 16 MHz >85 dB	± 12 MHz >85 dB	± 12 MHz >95 dB
	± 24 MHz >95 dB	± 18 MHz >100 dB	± 18 MHz >110 dB
NB GROUP DELAY VARIATION	<315 ns	<150 ns	<75 ns
NB MAX INPUT POWER RATING**	5.0 kW / 13 dB (crest factor)	4.0 kW / 13 dB (crest factor)	4.2 kW / 11 dB (crest factor)
TEMPERATURE RISE	<0.8 °C / 100 W	<1.0 °C / 100 W	<1.0 °C / 100 W
MASK COMPLIANT	Non critical mask	Non critical mask	Stringent mask

\* Data in table is typical data at 666 MHz. To fulfil mask transmitter shoulder level must be >36 dB. The combiner can be tuned for other specifications or bandwidth. Please contact us for a designed specification.  
\*\* Max power rating at <50 °C temprice at max frequency. Data are subjected to change without prior notice.