

# 2400 Series

# FREEMAN MARINE CAST HATCHES

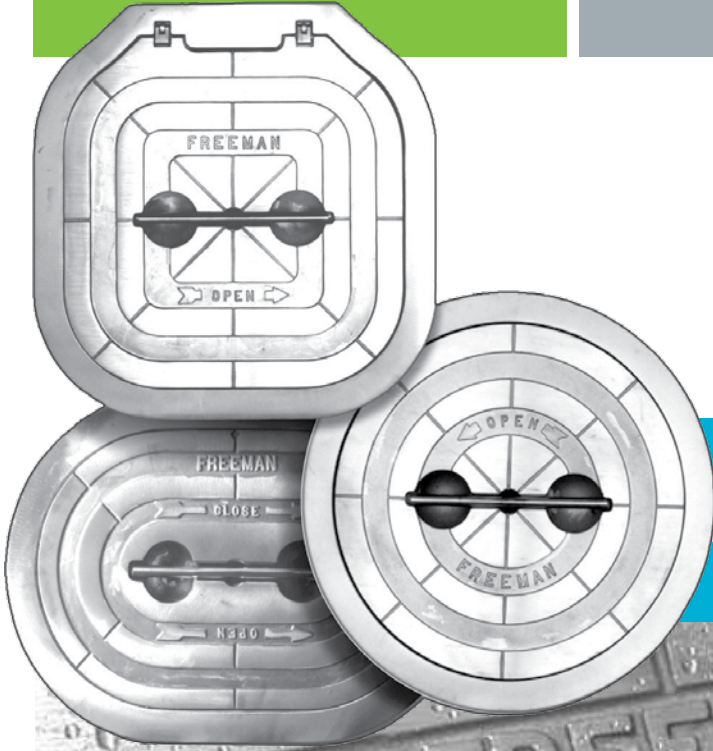

We are Passionate About Delivering  
Reliable *SOLUTIONS*  
Superior *QUALITY*  
World-Class *SUPPORT*



## Manufacturing Excellence



CONSULT | CREATE | DESIGN | MANUFACTURE | DELIVER

## ISO 9001:2015

Compliance with  
ISO 9001:2015  
Certified by TÜV Rheinland  
Of North America, Inc.

### Quality Policy Statement

- Consistently meet or exceed our customer’s expectation for product quality and performance.
- Consistently meet or exceed our customer’s expectation for product and service delivery.
- Continuously improve our processes and systems.
- Provide employee training to better serve our customers and to support personal growth.

#### CERTIFICATES AND ACCEPTANCES

AdvanTec’s Freeman cast hatch line has various approvals and certifications. Our hatches have been granted American Bureau of Shipping (ABS) Product Design Assessment Certification for 109 different models. Each of these models can be used on a number of ABS classed vessels in locations specified in the design assessment.

AdvanTec Marine constantly monitors maritime regulations, standards and classification society activities related to closure approvals.

#### AdvanTec Marine closures have received specific intended use acceptance by:

- ABS - American Bureau of Shipping
- DNV - Det Norske Veritas
- LR - Lloyds Register of Shipping
- GL - Germanischer Lloyds
- BV - Bureau Veritas
- MCA - Maritime Coastguard Agency
- RS - Russian Maritime Register of shipping
- RINA - RINA S.P.A., Italy
- CRS - Croatian Registry of Shipping
- USCG - US Coast Guard
- CCG - Canadian Coast Guard (Transport Canada)
- ABYC - American Boat & Yacht Council

✓ **Buy America Act Compliant** (52.225-1)

### APPROVALS AT A GLANCE

- ABS - type approval, certificate no. 13-HS1082451-PDA
- Lloyd’s Register - type approval certificate no. 03/00088(E3) & 9/60003(E1)
- U.S. Coast Guard, CE, ISO-12216 compliant

Approvals have been awarded and may be obtained for specific intended uses. AdvanTec Cast Hatches are currently in use on Coast Guard vessels and Naval craft of all types.

AdvanTec Marine can assist with specific intended use applications.



Over 350 self righting vessels 100% completely outfitted with AdvanTec hatches, doors, windows & portlights. The people you trust, trust AdvanTec Marine.

# CAST HATCHES

# 2400 Series



• LIFT OUT



• SURFACE HINGES

### Freeman Cast Hatches Attributes

- Evenly spaced dogging arms exert uniform force on the cover plate.
- Handle position shows when dogging arms are engaged or disengaged.
- Handle is always attached. Hatch and handle fit flush with the deck with the handle in a recessed locked position.
- Watertight hatches, designed to seal up to 30' intermittent head, the double-sealing gasket seals tighter under pressure.
- Versatile installation, hatches can be installed in steel, aluminum, wood, or fiber glass decks.
- Complete units include aluminum or steel mounting rings for bolt-in or weld-in installations.
- Dogging mechanism assures smooth consistent action; no binding or jamming.
- Quick-acting dogging eliminates over or under tightening; hatch operates the same each time.

- **TOP VALUE**
- **VERSATILE**
- **FAST ACTING**
- **RELIABLE**
- **EASY LIFT**
- **LOW MAINTENANCE**



• **CONCEALED YOKE HINGE**  
(Optional, selected models)

## Service. Value. Experience.

### ***FREEMAN Hatches have more quick-acting flush hatch experience, models and features than any manufacturer***

AdvanTec Marine's Freeman hatches are used on a wide variety of fishing boats, tugs, barges, research vessels, offshore tenders, rescue craft and other workboats. The Freeman hatch is designed for new boats, or replacing other hatches in standard openings, or for improving existing craft.

The hatches are fast acting and easy to use. Simply grasp the handle and pull, the shaft slides into place, and with less than a quarter turn, completely disengages the locking mechanism. The dogs and linked handle do the work smoothly in just a second.

Our easy lift system allows simple removal. With the locking mechanism disengaged, the hatch is resting on the deck ring and can be lifted out with one hand.

### HINGED HATCHES

For hinged models the unique hinging device allows the hatch to be opened more than 180° and "floats" when the hatch is closed to facilitate a tighter seal. Round hatches 18" and larger, and all oval and square hatches with aluminum covers are available hinged from the factory.

*Close-up view of standard Freeman "floating" hinge installed on hatch assembly, right.*

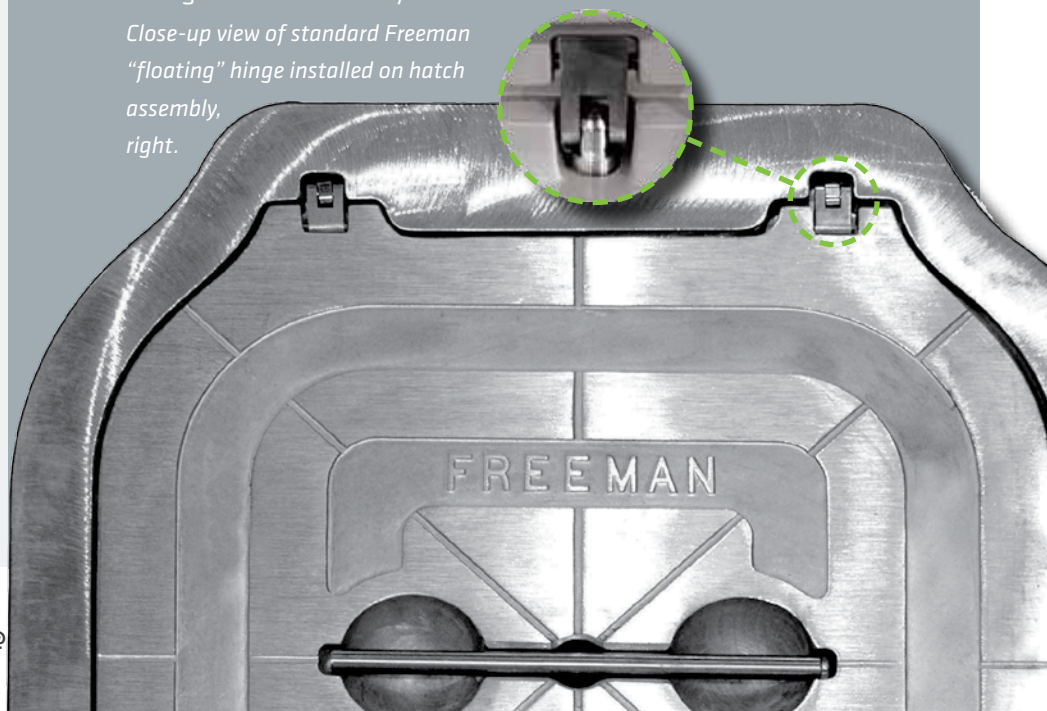

## Quality. Capability.

### Two Important Features Distinguish the Freeman Cast Hatch from Other Designs

- **Built in T-Handle**
- **Easy Operating Dogging Mechanism**

The standard pocketed, stainless steel T-handle is built in, permanently part of the hatch. Grasp the handle and pull, the shaft slides up into place, and with less than a quarter of a turn the locking mechanism completely disengages. The alignment of the handle shows when dogging arms are engaged or disengaged.

### Knife-edge or Compression Sealing?

#### Compression Seal 2400 Series Hatches

These hatches have easy-to-clean spigots, feature long gasket life, and are economical to purchase.



• Aluminum Deck Rings are intended to be weld installed into aluminum decks and bolt installed into other deck materials.

• Steel Deck Rings are to be weld installed into steel decks only.

• Watertight seal to 30 foot intermittent head, continuous 10 foot head top-loaded pressure (on properly installed and adjusted hatch assemblies).

#### Knife-edge Seal 2400 Series Hatches

These hatches feature a coaming with drain gutter and an aggressive sealing rim edge. A drain fitting can be installed to minimize water from entering enclosure when hatch is initially opened.



• Aluminum Deck Rings are intended to be weld installed into aluminum decks and bolt installed into other deck materials.

• Steel Deck Rings are to be weld installed into steel decks only.

#### TYPICAL HATCH COVER ASSEMBLY

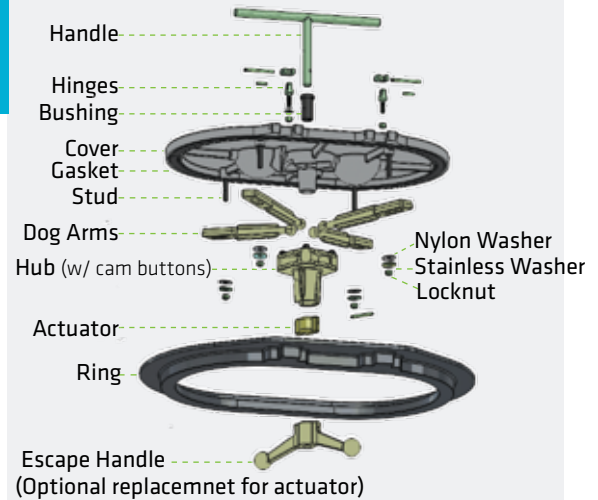

Cam at center of rotating mechanism exponentially increases force through fulcrum at the opposite end of the dog arm.

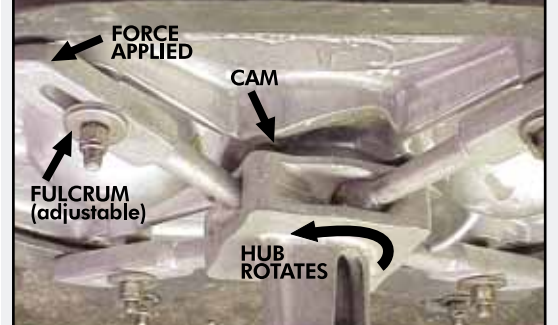

Evenly spaced dogging arms (either 3, 4 or 8 depending on size of hatch) exert uniform sealing pressure on the cover plate. The unique design, fit, and adjustability of Freeman's dogging mechanism assure smooth, consistent action; no binding or jamming of parts.

# CAST HATCHES - Oval

# 2400 Series



15" x 24" Oval lift-out,  
Aluminum ring



15" x 24" Oval hinged,  
Steel ring, Inside view



15" x 24" Oval lift-out,  
Steel ring



15" x 24" Oval hinged,  
Steel ring



Knife Edge Seal w/  
Aluminum Deck Ring  
A-K

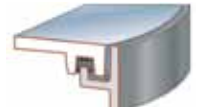
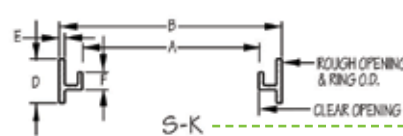

Knife Edge Seal w/  
Steel Deck Ring  
S-K



Compression Seal w/  
Aluminum Deck Ring  
A-C



Compression Seal w/  
Steel Deck Ring  
S-C

PART NO	SIZE	SHAPE	STYLE	RING	HATCH DIMENSIONS								COVER DIMENSIONS				MECHANISM	ASSEMBLY WEIGHT			
					CLEAR OPENING		ROUGH OPENING*		OVERALL (cover + ring)				MATERIAL		OVERALL			STD MATERIAL	DOG Qty	LBS	KGS
					A (in)	A (mm)	B (in)	B (mm)	C (in)	C (mm)	D	E	F	THICKNESS	(in)	(mm)					
2431-0002	12"x18"	Oval	Lift-Out	A-C	12.0x18.0	305x457	15.0x21.0	381x533	18.8x24.8	478x630	1.5	0.31	NA	ALUM	0.28	14.1x20.3	358x516	ALUM ALLOY	4	29	13.2
2431-0003	12"x18"	Oval	Lift-Out	S-C	12.0x18.0	305x457	14.8x19.8	376x503	14.8x19.8	376x503	1.3	0.25	NA	ALUM	0.29	14.1x20.3	358x516	ALUM ALLOY	4	30	13.6
2471-0002	12"x18"	Oval	Hinged	A-C	12.0x18.0	305x457	15.0x21.0	381x533	18.8x24.8	478x630	1.5	0.31	NA	ALUM	0.28	14.1x20.3	358x516	ALUM ALLOY	4	31	14.1
2471-0003	12"x18"	Oval	Hinged	S-C	12.0x18.0	305x457	14.8x20.8	376x503	17.2x20.8	437x529	1.3	0.25	NA	ALUM	0.29	14.1x20.3	358x516	ALUM ALLOY	4	31	14.1
2433-0002	15"x24"	Oval	Lift-Out	A-C	14.8x23.7	376x603	17.7x26.7	450x677	21.3x30.3	541x770	1.5	0.25	NA	ALUM	0.22	16.3x25.9	414x658	ALUM ALLOY	4	35	15.9
2433-0003	15"x24"	Oval	Lift-Out	S-C	14.8x23.7	376x603	17.5x26.5	445x673	17.5x26.5	445x673	1.3	0.25	NA	ALUM	0.22	16.3x25.9	414x658	ALUM ALLOY	4	37	16.8
2434-0002	15"x24"	Oval	Lift-Out	A-K	15.2x24.2	386x615	17.9x26.9	455x684	21.0x30.0	533x762	1.6	0.31	0.6	ALUM	0.21	17.7x26.7	450x678	ALUM ALLOY	4	35	15.9
2434-0003	15"x24"	Oval	Lift-Out	S-K	15.2x24.2	386x615	17.9x26.7	454x678	17.9x26.7	454x678	2.5	0.31	0.25	ALUM	0.21	17.6x26.4	447x671	ALUM ALLOY	4	54	24.5
2473-0002	15"x24"	Oval	Hinged	A-C	14.6x23.5	371x597	17.6x26.5	447x673	21.6x30.5	549x775	1.5	0.31	NA	ALUM	0.2	16.1x25.7	409x653	ALUM ALLOY	4	37	16.8
2473-0003	15"x24"	Oval	Hinged	S-C	14.6x23.5	371x597	17.6x26.5	440x670	19.7x26.5	500x673	1.3	0.31	0.25	ALUM	0.2	16.1x25.7	409x653	ALUM ALLOY	4	38	17.2
2474-0002	15"x24"	Oval	Hinged	A-K	15.2x24.2	388x615	17.2x26.2	437x665	21.0x30.0	533x762	1.6	0.31	0.6	ALUM	0.21	17.4x26.3	442x668	ALUM ALLOY	4	35	15.9
2474-0003	15"x24"	Oval	Hinged	S-K	15.2x24.2	388x615	20.1x26.7	454x678	20.1x26.7	510x678	2.5	0.31	0.25	ALUM	0.21	17.0x26.1	432x668	ALUM ALLOY	4	60	27.2
2483-0107	15"x24"	Oval	Lift-Out	S-C	15.1x24.1	384x613	16.8x25.6	427x650	16.8x25.6	427x650	1.5	0.25	NA	DUCT IRON	0.38	17.0x26.1	432x668	STAIN STEEL	4	85	28.6
2435-0002	19"x26"	Oval	Lift-Out	A-K	19.2x26.2	488x665	21.2x28.2	538x716	25.0x32.0	635x813	1.6	0.31	0.6	ALUM	0.29	21.5x28.4	546x721	ALUM ALLOY	4	43	19.5
2435-0003	19"x26"	Oval	Lift-Out	S-K	19.2x26.2	488x665	21.7x28.7	551x729	21.7x28.7	551x729	2.5	0.31	0.25	ALUM	0.29	21.3x28.4	546x721	ALUM ALLOY	4	61	27.7
2475-0002	19"x26"	Oval	Hinged	A-K	19.2x26.2	488x665	21.2x28.2	538x716	27.2x32.4	691x823	1.6	0.31	0.6	ALUM	0.29	21.3x28.4	546x721	ALUM ALLOY	4	44	20
2475-0003	19"x26"	Oval	Hinged	S-K	19.2x26.2	488x665	24.0x28.8	610x732	24.0x28.8	610x732	2.5	0.31	0.25	ALUM	0.29	21.3x28.4	546x721	ALUM ALLOY	4	67	30

\*ROUGH OPENING DIMENSIONS DO NOT INCLUDE HINGE POCKETS

# 2400 Series

# CAST HATCHES - Round



24" Round lift-out,  
Steel ring



8" Round lift-out, Aluminum ring



18" Round lift-out,  
Steel ring



20" Round hinged,  
Aluminum ring

PART NO	SIZE	SHAPE	STYLE	RING	HATCH DIMENSIONS									COVER DIMENSIONS				MECHANISM		ASSEMBLY WEIGHT	
					CLEAR OPENING		ROUGH OPENING*		OVERALL (cover + ring)					MATERIAL		OVERALL		STD MATERIAL	DOG Qty	LBS	KGS
					A (in)	A (mm)	B (in)	B (mm)	C (in)	C (mm)	D	E	F	MTRL	THKNSS	in	mm				
2401-0002	8"	Round	Lift-Out	A-C	7.9	201	10.3	262	12.2	310	1.1	0.31	NA	ALUM	0.23	9.8	249	ALLUM ALLOY	3	8	3.6
2402-0002	12"	Round	Lift-Out	A-C	11.9	302	14.8	376	17.4	442	1.3	0.31	NA	ALUM	0.19	13.9	353	ALLUM ALLOY	3	13	5.9
2402-0003	12"	Round	Lift-Out	S-C	11.9	302	14.5	368	14.7	373	1.3	0.25	NA	ALUM	0.19	13.9	353	ALLUM ALLOY	3	16	7.3
2403-0002	15"	Round	Lift-Out	A-C	15	381	17.8	452	12.5	546	1.3	0.31	NA	ALUM	0.29	17	432	ALLUM ALLOY	3	23	10.4
2403-0003	15"	Round	Lift-Out	S-C	15	381	17.6	447	17.8	452	1.3	0.25	NA	ALUM	0.29	17	432	ALLUM ALLOY	3	26	11.8
2404-0002	18"	Round	Lift-Out	A-C	18	457	20.9	530	24.5	622	1.4	0.31	NA	ALUM	0.26	20	508	ALLUM ALLOY	3	30	13.6
2404-0003	18"	Round	Lift-Out	S-C	18	457	20.5	521	20.7	526	1.3	0.25	NA	ALUM	0.26	20	508	ALLUM ALLOY	3	32	14.5
2405-0002	18"	Round	Lift-Out	A-K	18	457	20	508	24	607	1.5	0.38	0.8	ALUM	0.24	20.4	518	ALLUM ALLOY	3	38	17.2
2405-0003	18"	Round	Lift-Out	S-K	18	457	20.6	523	21.1	536	2.5	0.31	1	ALUM	0.24	20.7	526	ALLUM ALLOY	3	36	16.3
2441-0002	18"	Round	Hinged	A-C	18	457	25.7	653	24.5	622	1.6	0.27	NA	ALUM	0.38	20	508	ALLUM ALLOY	3	35	15.9
2441-0003	18"	Round	Hinged	S-C	18	457	20.8	528	20.5	521	1.3	0.25	NA	ALUM	0.38	20	508	ALLUM ALLOY	3	38	17.2
2442-0002	18"	Round	Hinged	A-K	18	457	20.7	527	24.5	607	1.5	0.38	0.8	ALUM	0.24	20.7	526	ALLUM ALLOY	3	39	17.7
2442-0003	18"	Round	Hinged	S-K	18	457	20.6	523	22.9	580	2.5	0.31	1	ALUM	0.24	20.7	526	ALLUM ALLOY	3	42	19.1
2481-0107	18"	Round	Lift-Out	S-C	18	457	20.5	521	20.3	516	1.5	0.25	NA	DUCT IRON	0.41	19.9	505	STAIN STEEL	3	75	34
2406-0002	20"	Round	Lift-Out	A-C	19.8	503	22.8	579	26.5	673	1.3	0.31	NA	ALUM	0.26	21.9	556	ALLUM ALLOY	4	36	16.3
2406-0003	20"	Round	Lift-Out	S-C	19.8	503	22.4	569	22.3	566	1.3	0.25	NA	ALUM	0.26	21.9	556	ALLUM ALLOY	4	37	16.8
2407-0002	20"	Round	Lift-Out	A-K	20	508	22	559	26	660	1.4	0.38	0.7	ALUM	0.35	21.9	556	ALLUM ALLOY	4	44	20
2407-0003	20"	Round	Lift-Out	S-K	20	508	22.6	574	22.3	566	2.5	0.31	1	ALUM	0.35	21.6	549	ALLUM ALLOY	4	41	18.6
2443-0002	20"	Round	Hinged	A-C	19.6	498	22.8	579	26.5	673	1.7	0.4	NA	ALUM	0.29	21.9	556	ALLUM ALLOY	4	44	20
2443-0003	20"	Round	Hinged	S-C	19.6	498	22.4	569	22.1	561	1.3	0.25	NA	ALUM	0.29	21.9	556	ALLUM ALLOY	4	47	21.3
2444-0002	20"	Round	Hinged	A-K	20	508	22	559	26	660	1.4	0.38	0.7	ALUM	0.35	22.4	569	ALLUM ALLOY	4	45	20.4
2444-0003	20"	Round	Hinged	S-K	20	508	22.6	579	22.9	582	2.5	0.31	1	ALUM	0.35	22.4	569	ALLUM ALLOY	4	48	21.8

\*ROUGH OPENING DIMENSIONS DO NOT INCLUDE HINGE POCKETS #DUCTILE IRON (see page 13 for loading limits)

# CAST HATCHES - Round

# 2400 Series



Knife Edge Seal w/  
Aluminum Deck Ring  
A-K

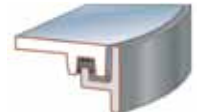
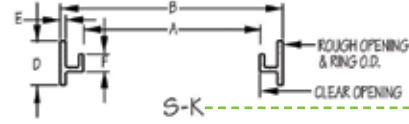

Knife Edge Seal w/  
Steel Deck Ring  
S-K



Compression Seal w/  
Aluminum Deck Ring  
A-C

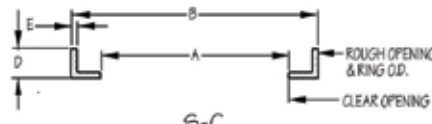
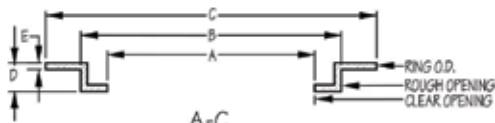

Compression Seal w/  
Steel Deck Ring  
S-C

PART NO	SIZE	SHAPE	STYLE	RING	DIMENSIONS								COVER				MECHANISM			ASSEMBLY WEIGHT	
					CLEAR OPENING		ROUGH OPENING*		OVERALL				OVERALL		STD MATERIAL	DOG Qty	LBS	KGS			
					A (in)	A (mm)	B (in)	B (mm)	C (in)	C (mm)	D	E	F	MTRL					THKNSS	in	mm
2408-0002	22"	ROUND	LIFT-OUT	A-C	22	559	24.8	630	28.5	724	1.6	0.31	NA	ALUM	0.31	24	610	ALUM ALLOY	4	39	17.7
2408-0003	22"	ROUND	LIFT-OUT	S-C	22	559	24.6	625	24.7	627	1.5	0.25	NA	ALUM	0.31	24	610	ALUM ALLOY	4	40	18.1
2411-0002	24"	ROUND	LIFT-OUT	A-C	23.3	592	26.6	676	30.5	775	1.4	0.31	NA	ALUM	0.37	25.8	665	ALUM ALLOY	4	52	23.6
2411-0003	24"	ROUND	LIFT-OUT	S-C	23.3	592	26.7	679	26.2	665	1.5	0.25	NA	ALUM	0.37	25.8	665	ALUM ALLOY	4	54	24.5
2412-0002	24"	ROUND	LIFT-OUT	A-K	24.1	612	27.1	689	30.6	778	1.6	0.38	0.6	ALUM	0.42	26.5	673	ALUM ALLOY	4	65	29.5
2412-0003	24"	ROUND	LIFT-OUT	S-K	24.1	612	26.7	678	26.5	673	2.5	0.31	1.0	ALUM	0.42	26.2	665	ALUM ALLOY	4	59	28.8
2447-0002	24"	ROUND	HINGED	A-C	23.4	594	26.4	671	30.5	775	1.7	0.4	NA	ALUM	0.41	25.8	665	ALUM ALLOY	4	59	28.8
2447-0003	24"	ROUND	HINGED	S-C	23.4	594	26.5	673	29.3	743	1.5	0.25	NA	ALUM	0.41	25.8	665	ALUM ALLOY	4	62	28.1
2448-0002	24"	ROUND	HINGED	A-K	24.1	612	26.1	663	30.6	777	1.6	0.38	0.6	ALUM	0.42	25.8	665	ALUM ALLOY	4	66	29.9
2448-0003	24"	ROUND	HINGED	S-K	24.1	612	26.7	678	26.3	668	2.5	0.31	1.0	ALUM	0.42	25.8	655	ALUM ALLOY	4	65	29.5
2482-0107	24"	ROUND	LIFT-OUT	S-C	23.3	592	26.5	673	26.3	668	1.5	0.25	NA	#DUCT IRON	0.36	25.8	655	STAIN STEEL	4	110	49.9
2415-0006	30"	ROUND	LIFT-OUT	A-C	30	762	33.5	851	37.3	947	1.4	0.31	NA	ALUM	0.41	32.5	826	STAIN STEEL	4	81	36.7
2415-0007	30"	ROUND	LIFT-OUT	S-C	30	762	33.3	846	33.1	841	1.3	0.25	NA	ALUM	0.39	32.5	826	STAIN STEEL	4	87	39.5
2452-0006	30"	ROUND	HINGED	A-C	30	762	33.5	851	37.3	947	1.7	0.4	NA	ALUM	0.46	32.5	826	STAIN STEEL	4	82	37.2
2452-0007	30"	ROUND	HINGED	S-C	30	762	33.3	846	33.1	841	1.5	0.25	NA	ALUM	0.49	32.5	826	STAIN STEEL	4	118	53.5

\*ROUGH OPENING DIMENSIONS DO NOT INCLUDE HINGE POCKETS

#DUCTILE IRON (see page 13 for loading limits)



photo by Alicia Myrick

# 2400 Series

# CAST HATCHES - Rectangular/Square



22" Square hinged, Inside view



22" Square hinged, Steel ring



18" x 24" Rectangular Hinged, Aluminum ring



22" Square hinged, Aluminum ring



Knife Edge Seal w/ Aluminum Deck Ring A-K

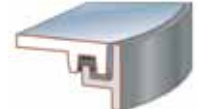
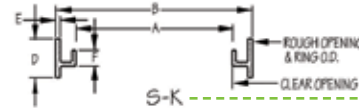
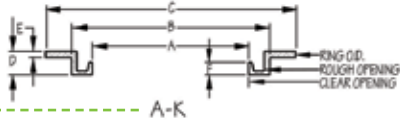

Knife Edge Seal w/ Steel Deck Ring S-K

PART NO	SIZE	SHAPE	STYLE	RING	HATCH DIMENSIONS											MECHANISM		ASSEMBLY WEIGHT		
					CLEAR OPENING		ROUGH OPENING*		OVERALL (cover + ring)				COVER		STD MATERIAL	DOC Qty	LBS	KGS		
					A (in)	A (mm)	B (in)	B (mm)	C (in)	C (mm)	D	E	F	MTRL					THKNSS	
2421-0002	18"x24"	Rectangle	Lift-Out	A-K	18.0x24.0	457x610	20.5x26.5	521x673	24.5x30.5	622x775	1.6	0.38	0.7	ALUM	0.2	ALUM ALLOY	4	36	16.3	
2421-0003	18"x24"	Rectangle	Lift-Out	S-K	18.0x24.0	457x610	20.5x26.5	521x673	20.4x26.4	518x671	2.5	0.31	0.9	ALUM	0.2	ALUM ALLOY	4	61	27.7	
2461-0002	18"x24"	Rectangle	Hinged	A-K	18.0x24.0	457x610	20.5x26.5	521x673	24.5x30.5	622x775	1.6	0.38	0.7	ALUM	0.2	ALUM ALLOY	4	36	16.3	
2461-0003	18"x24"	Rectangle	Hinged	S-K	18.0x24.0	457x610	20.5x26.4	521x673	22.8x26.3	579x668	2.5	0.31	0.9	ALUM	0.2	ALUM ALLOY	4	61	27.7	
2436-0002	24"x28"	Rectangle	Lift-Out	A-K	24.6x28.6	625x727	27.5x31.5	699x799	31.2x35.2	793x894	1.6	0.38	0.7	ALUM	0.2	ALUM ALLOY	4	61	27	
2436-0003	24"x28"	Rectangle	Lift-Out	S-K	24.6x28.6	625x727	27.5x31.5	699x799	27.1x31.1	688x790	2.5	0.31	0.9	ALUM	0.3	ALUM ALLOY	4	83	37.4	
2476-0002	24"x28"	Rectangle	Hinged	A-K	24.6x28.4	629x724	29.6x31.4	752x797	33.1x34.9	840x887	1.6	0.38	0.7	ALUM	0.3	ALUM ALLOY	4	62	28.1	
2476-0003	24"x28"	Rectangle	Hinged	S-K	24.6x28.4	629x724	29.6x31.4	752x797	29.6x33.1	752x841	2.5	0.31	0.9	ALUM	0.3	ALUM ALLOY	4	84	37.9	
2429-0002	30"x36"	Rectangle	Lift-Out	A-K	30.5x36.5	775x927	32.8x38.8	834x987	36.3x42.3	923x1075	2.5	0.31	0.9	ALUM	0.3	ALUM ALLOY	8	102	46.3	
2429-0003	30"x36"	Rectangle	Lift-Out	S-K	30.5x36.5	775x927	33.5x39.5	850x1003	33.5x39.5	850x1003	2.5	0.31	0.9	ALUM	0.3	ALUM ALLOY	8	119	54	
2469-0002	30"x36"	Rectangle	Hinged	A-K	30.6x36.6	776x930	32.8x38.8	834x987	38.1x42.3	967x1075	1.6	0.38	0.7	ALUM	0.3	ALUM ALLOY	8	93	42.4	
2469-0003	30"x36"	Rectangle	Hinged	S-K	30.0x36.0	762x914	33.5x39.5	850x1003	37.5x39.3	952x998	2.5	0.31	0.9	ALUM	0.3	ALUM ALLOY	8	130	59	
2422-0002	20"x20"	Square	Lift-Out	A-K	20.3x20.3	517x517	22.8x22.8	579x579	26.8x26.8	681x681	1.6	0.38	0.7	ALUM	0.5	ALUM ALLOY	4	43	19.5	
2422-0003	20"x20"	Square	Lift-Out	S-K	20.3x20.3	517x517	22.8x22.8	579x579	22.5x22.5	572x572	2.5	0.31	0.9	ALUM	0.5	ALUM ALLOY	4	74	33.6	
2462-0002	20"x20"	Square	Hinged	A-K	20.3x20.3	517x517	22.8x22.8	579x579	28.2x26.4	715x672	1.6	0.38	0.7	ALUM	0.3	ALUM ALLOY	4	45	20.4	
2462-0003	20"x20"	Square	Hinged	S-K	20.3x20.3	517x517	22.8x22.8	579x579	25.2x22.8	640x579	2.5	0.31	0.9	ALUM	0.3	ALUM ALLOY	4	76	34.5	
2423-0002	22"x22"	Square	Lift-Out	A-K	22.0x22.0	559x559	24.5x24.5	622x622	28.5x28.5	724x724	1.6	0.38	0.7	ALUM	0.3	ALUM ALLOY	4	45	20.4	
2423-0003	22"x22"	Square	Lift-Out	S-K	22.0x22.0	559x559	24.5x24.5	622x622	24.7x24.7	627x627	2.5	0.31	0.9	ALUM	0.3	ALUM ALLOY	4	92	41.7	
2463-0002	22"x22"	Square	Hinged	A-K	22.0x22.0	559x559	24.5x24.5	622x622	28.5x28.5	724x724	1.6	0.38	0.7	ALUM	0.3	ALUM ALLOY	4	46	20.9	
2463-0003	22"x22"	Square	Hinged	S-K	22.0x22.0	559x559	24.5x24.5	622x622	26.8x24.3	681x617	2.5	0.31	0.9	ALUM	0.3	ALUM ALLOY	4	92	41.7	
2423-0002	22"x22"	Square	Lift-Out	A-K	22.0x22.0	559x559	24.5x24.5	622x622	28.5x28.5	724x724	1.6	0.38	0.7	ALUM	0.3	ALUM ALLOY	4	45	20.4	
2423-0003	22"x22"	Square	Lift-Out	S-K	22.0x22.0	559x559	24.5x24.5	622x622	24.6x24.9	625x625	2.5	0.31	0.9	ALUM	0.3	ALUM ALLOY	4	92	41.7	
2424-0002	24"x24"	Square	Lift-Out	A-K	24.6x24.6	625x625	27.5x27.5	697x697	31.2x31.2	792x792	1.6	0.38	0.7	ALUM	0.3	ALUM ALLOY	4	63	28.6	
2424-0003	24"x24"	Square	Lift-Out	S-K	24.0x24.0	610x610	27.4x27.4	695x695	27.4x27.4	695x695	2.5	0.31	0.9	ALUM	0.3	ALUM ALLOY	4	82	37.2	

\*ROUGH OPENING DIMENSIONS DO NOT INCLUDE HINGE POCKETS

\*\*REQUIRES ESCAPE HANDLE AS STANDARD

Continued on next page



# CAST HATCHES - Square

# 2400 Series



Knife Edge Seal w/  
Aluminum Deck Ring  
A-K

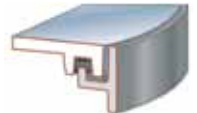
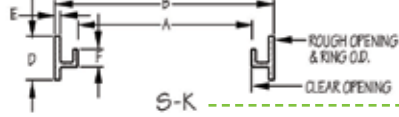
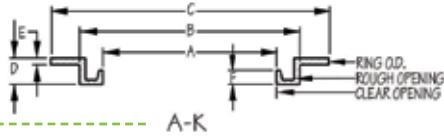

Knife Edge Seal w/  
Steel Deck Ring  
S-K

PART NO	SIZE	SHAPE	STYLE	RING	DIMENSIONS											MECHANISM		ASSEMBLY WEIGHT	
					CLEAR OPENING		ROUGH OPENING*		OVERALL				COVER		STD MATERIAL	DOG Qty	LBS	KGS	
					A (in)	A (mm)	B (in)	B (mm)	C (in)	C (mm)	D	E	F	MTRL					THKNSS
2480-0106	24"x24"	Square	Hinged	A-K	24.8x24.8	630x630	27.3x29.2	693x742	31.2x35.2	793x894	1.6	0.38	0.7	D I	0.3	STAIN STEEL	4	133	60.3
2480-0107	24"x24"	Square	Hinged	S-K	24.7x24.7	629x629	27.4x29.5	695x748	29.6x27.4	752x695	2.5	0.31	0.9	D I	0.3	STAIN STEEL	4	155	70.3
2464-0002	24"x24"	Square	Hinged	A-K	24.0x24.0	610x610	27.5x27.5	698x698	33.1x31.2	840x792	1.6	0.38	0.7	ALUM	0.3	ALUM ALLOY	4	59	26.7
2464-0003	24"x24"	Square	Hinged	S-K	24.0x24.0	610x610	27.4x27.4	695x695	29.6x27.4	695x695	2.5	0.31	0.9	ALUM	0.3	ALUM ALLOY	4	87	39.5
2427-0002	27"x27"	Square	Lift-Out	A-K	27.2x27.2	690x690	29.6x29.6	752x752	33.6x33.6	854x854	1.6	0.32	0.8	ALUM	0.3	ALUM ALLOY	4	63	28.6
2427-0003	27"x27"	Square	Lift-Out	S-K	27.2x27.2	690x690	29.6x29.6	750x750	29.6x29.6	752x752	2.5	0.31	1.9	ALUM	0.3	ALUM ALLOY	4	85	38.6
2426-0006	30"x30"	Square	Lift-Out	A-K	30.0x30.0	762x762	32.5x32.5	826x826	36.5x36.5	927x927	1.6	0.25	0.7	ALUM	0.3	STAIN STEEL	4	75	31
2426-0007	30"x30"	Square	Lift-Out	S-K	30.0x30.0	762x762	32.5x32.5	826x826	32.6x32.6	828x828	2.5	0.31	0.9	ALUM	0.3	STAIN STEEL	4	113	51.3
2466-0006	30"x30"	Square	Hinged	A-K	30.0x30.0	762x762	32.5x32.5	826x826	36.5x36.5	927x927	1.6	0.25	0.7	ALUM	0.2	STAIN STEEL	4	78	35.4
2466-0007	30"x30"	Square	Hinged	S-K	30.0x30.0	762x762	32.5x32.5	826x826	34.8x32.6	884x829	2.5	0.31	0.9	ALUM	0.2	STAIN STEEL	4	114	51.7
2428-0002 0001**	36"x36"	Square	Lift-Out	A-K	36.0x36.0	914x914	39.3x39.3	998x998	42.5x42.5	1080x1080	2.5	0.31	0.9	ALUM	0.4	ALUM ALLOY	8	104	48
2428-0003 0001**	36"x36"	Square	Lift-Out	S-K	36.0x36.0	914x914	39.3x39.3	998x998	39.2x39.0	996x991	2.5	0.31	0.9	ALUM	0.4	ALUM ALLOY	8	134	60.8
2468-0002 0001**	36"x36"	Square	Hinged	A-K	36.0x36.0	914x914	39.3x39.3	998x998	44.2x42.2	1067x1067	2.5	0.31	0.9	ALUM	0.3	ALUM ALLOY	8	119	54
2468-0003 0001**	36"x36"	Square	Hinged	S-K	36.0x36.0	914x914	39.3x39.3	998x998	43.6x39.3	1106x997	2.5	0.31	0.9	ALUM	0.3	ALUM ALLOY	8	149	67.6

\*ROUGH OPENING DIMENSIONS DO NOT INCLUDE HINGE POCKETS

\*\*REQUIRES ESCAPE HANDLE AS STANDARD

#DUCTILE IRON (see page 13 for loading limits)



## Handle Options

### Inside Escape Handle Options

-0001 **0031-2064**  
[AL] w/ Pin  
18" Hatches and larger

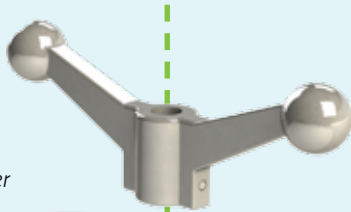

-0002 **0031-2065**  
7.5" O. D.  
[AL] w/ Pin  
20" Hatch and larger



-0003 **0031-2087**  
12.5" O.D.  
[AL] w/ Pin  
20" Hatches and larger



-0004 **0031-2119**  
[SS mill finish] w/ Pin  
Use with hatches that have SS  
dogging mechanism



### Topside Handle Options



**Standard Handle**  
**0031-2158**  
[SS] Standard  
Integral Handle  
Includes o-ring and pin

### Optional Removable Handles:

**0435-2012**  
Winch Handle  
Use with Flat Top  
Bi-square Spindle



**0031-2264**  
Interlocking T-Wrench  
Use with Interlocking  
Spindle



**0021-2008**  
T-Style Wrench Handle  
Use with T-Style  
Slot Spindle



## Hinge Options



**0461-2205**  
[SS] Standard  
Hinge Assembly  
Double Acting  
Allows cover to lay flat



**0461-2202**  
[SS] Standard  
Hinge Assembly  
Single Pivot  
Use with hold open or  
Gas Shocks

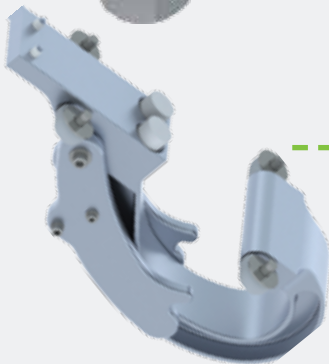

**0461-2077**  
Yoke Hinge, Concealed  
Includes Hold Open

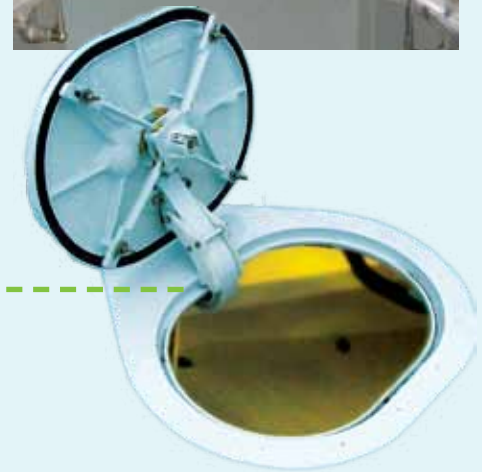

**0461-2071**  
[SS] 2 x 4 Hinge, Raised  
Flush with Teak

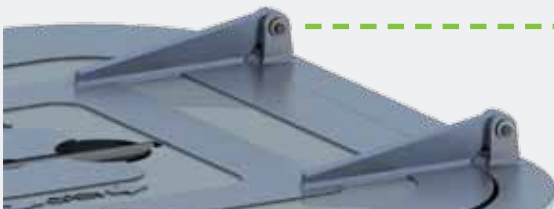

**0462-2021**  
Blade Hinge  
Use with Raised Coaming &  
Vertical Mount Hatches



## Hold Open Options

### Miscellaneous Options

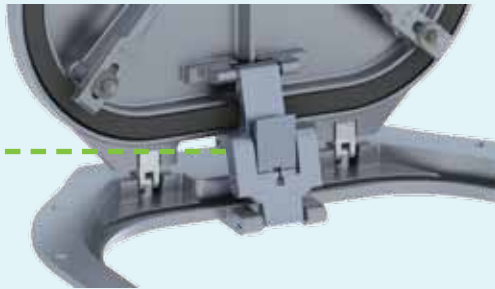
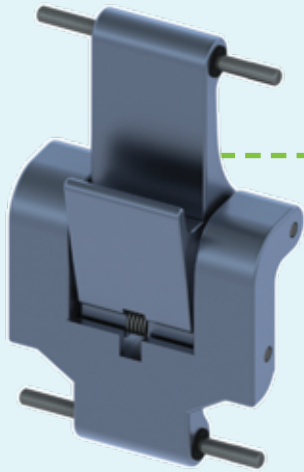

**0031-2007**  
Hold Open  
Use with 18", 20", 24", 18"x24", 15"x24",  
20"x20", 22"x22", 24"x24", 19"x26"

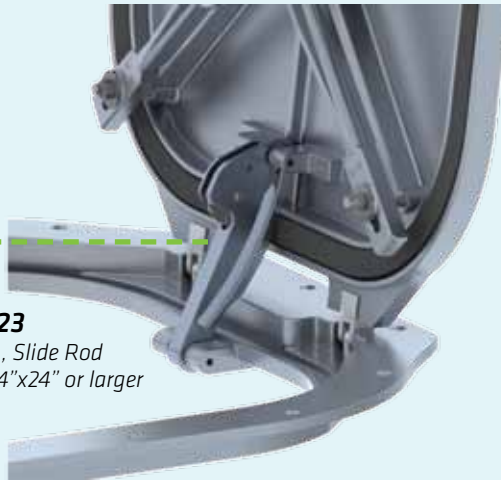

**0423-1023**  
Hold Open, Slide Rod  
Use with 24"x24" or larger



**Gas Shocks [2]/Hatch**  
20"x20" up to 36"x36"  
Square or Rectangular hatches only

**Coaming Drain**  
Use with Knife-Edge



**Drill & Countersink**  
Aluminum Rings with Flange

**Sensor Assembly**  
Magnetic Contact  
Senses if hatch isn't  
Dogged Completely

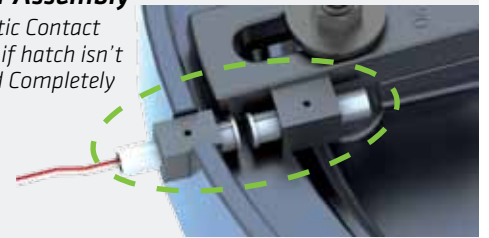

Hatch Shown  
with Inside Escape Handle, Drain Hold Open  
Ring Drilled and Countersunk

## Ductile Iron Loading Limits

Below is the maximum allowable loading for cast iron covers listed and their aluminium equivalents. The following values CANNOT be used to extrapolate loading limits on other models or cover/ring combinations.

Hatch Part Number, Description	Max Load kN (lbf)	Max Load- Fatigue kN (lbf)	Max Watertight pressure kPa (psi)	Comment
2483-1101 (0136-4001), Oval 15"x24" Cast Iron	13 (2900)	-	28 (4)	All rings excluding aluminium
2433-1001 (2433-3001), Oval 15"x24" Aluminium	2.5 (550)	1.5 (350)	28 (4)	All rings, As cast
2482-1101 (0136-4003), Round 24" Cast Iron	17 (3800)	-	43 (6.2)	All rings excluding aluminium
2411-1001 (2411-3001), Round 24" Aluminium	4.5 (1000)	3 (650)	43 (6.2)	All rings, As cast
2481-1101 (0136-4002), Round 18" Cast Iron	16 (3600)	-	38 (5.5)	All rings excluding aluminium
2404-1001 (0111-4106), Round 18" Aluminium	3 (650)	2 (450)	38 (5.5)	All rings, As cast
2480-1101 (0136-4006), Hinged Square 24"x24" Cast Iron	*3.5 (800)	-	*55 (8)	All rings excluding aluminium
2464-1001 (2464-3001), Hinged Square 24"x24" Aluminium	1.5 (350)	1 (200)	55 (8)	All rings, As cast
* Failure mode is non-typical and found at hinge pin				

CONSULT | CREATE | DESIGN | MANUFACTURE | DELIVER

### Definitions

- **Max load:** maximum point load acceptable on any point on top of the cover.
- **Max load-fatigue:** maximum cyclic point load acceptable on any point on top of the cover. Higher loads will result in non-infinite fatigue life which may be acceptable in certain applications.
- **Max watertightness pressure:** Maximum tank test pressure (inside direction).

### Analysis

The load results are based on finite element analysis of hatch/ring combinations. In the case of aluminium castings, the fatigue limit is also included as it is lower than the yield limit. A 2x safety factor was assumed in all instances.

The watertightness pressures listed are based on Type Approvals and previous sealing results. Note that only the aluminium models hold TA certificates.

**Higher loading results may be acceptable based on the application and other requirements. Please contact Engineering if additional clarity is required.**

## Quick Availability.

### GUARANTEED QUALITY

These items are in stock or ready to ship within 3 weeks or less, guaranteed. If not, AdvanTec Marine will pay for ground shipping within the Continental North America\*. \*Excluding Alaska & Hawaii.

#### 250 SERIES WEATHERTIGHT DOORS

##### 250 HINGED DOOR & 250 DUTCH DOOR

- Marine Grade .090" Aluminum Captured Panel Skins Mill Finish
- Welded 6063 Flanged Aluminum Frame
- 4" Radius Corners
- Gasket on Frame
- Insulation Korolite Rigid Foam Core
- Bolt-in or Weld-in Frames
- (2) Individual Nylon Dogs
- Stainless Steel Hinges and Fasteners
- Trioving Lockset with 3 keys



250 Hinged



250 Dutch

#### 1212 SERIES WATERTIGHT DOORS

##### HINGED WATERTIGHT DOOR

- Marine Grade Interprime 198 Red Oxide Primer Finish
- Welded Mild Steel, Radius Formed Corners
- Gasket on Door Panel for Long Life and Positive Sealing
- .250" Thick, Outside Mild Steel Panel
- (4) Individual Steel Dogs
- (3) Welded Steel Panel Hinges
- Inside and Outside Steel Pull Handles



1212 Watertight

#### 300X SERIES SLIDING DOORS

##### SINGLE PANEL SLIDING DOOR

- Commercial Duty Closure Designed for Offshore Use
- Marine Grade 6063 Aluminum
- Mill Finish
- Insulation Korolite Rigid Foam Core
- Tempered Window
- Trioving Lockset with 3 keys



300X Sliding

## Our Brands



Diamond  
Sea Glaze



**FREEMAN**  
MARINE EQUIPMENT



**PACIFIC COAST**  
MARINE



**STEELHEAD**  
**MARINE**



**USA**  
SLIDING  
DOORS

AdvanTec Marine is a member of the  
Advantec Global Group. For more information go to:

[www.advantecglobal.com](http://www.advantecglobal.com)

## *The AdvanTec Advantage*

- Five Marine Brands - Single Source Purchasing
- Service & Installation Available
- Over 120 Years of Combined Technical Experience
- Industry Leading 3-Year Warranty\*
- The Right Product For Your Job

AdvanTec Marine is one of the largest closure manufactures in the world delivering class approved projects, 150,000 **Doors, Windows, Hatches, Cranes, Portlights** and **Components** shipped to over 50 countries.

Made up of collaborating marine brands, AdvanTec Marine has some of the best known brands in the marine industry: **Diamond Sea Glaze, Freeman Marine, Pacific Coast Marine, Steelhead Marine, and USA Sliding Doors.**

The team at AdvanTec is driven by passion and creativity to deliver manufacturing excellence in the marine industry. Combine that with our corporate philosophy that runs deep: Consult, Create, Design, Manufacture & Deliver; and you will see a perfect recipe for consistent innovation.



CONSULT | CREATE | DESIGN | MANUFACTURE | DELIVER

### **AdvanTec's Industry Leading Warranty\***

All Powered Equipment:

- 24 months from shipment + 12 months
- Additional 12 months requires commissioning by AdvanTec Marine or certified technician

All Non-Powered Equipment:

- 36 months from shipment date

# FREEMAN MARINE CAST HATCHES

## Contact



### INFO

www.advantecglobal.com  
www.advantecmarine.com  
sales@advantecglobal.com  
1.800.770.0455

### ADDRESSES

AdvanTec Marine Sales Office  
Suite A-106  
16531 13th Avenue West  
Lynnwood, WA 98037  
USA

AdvanTec Manufacturing USA  
28336 Hunter Creek Rd  
Gold Beach, OR 97444  
USA

AdvanTec Manufacturing Canada  
46373 Progress Way  
Chilliwack, BC V2R 0C3  
Canada



## Replacement Parts

Freeman hatch gaskets and bushings, for periodic scheduled maintenance, and parts to repair a damaged hatch are always available. AdvanTec Manufacturing USA and its distributors keep substantial inventories of these items in stock for immediate shipment.

AdvanTec Marine supports all of its brands with replacement parts. Our specialized parts team can assist.

### Parts information and where-to-buy:

[www.freemanmarine.com](http://www.freemanmarine.com) | [am.parts@advantecglobal.com](mailto:am.parts@advantecglobal.com) | 1.800.770.0455 Replacement Parts

### For drawings of individual hatches, see product catalog:

[www.advantecglobal.com/marine/freeman-marine/hatches/2400-series/cast-aluminum-flush-deck/](http://www.advantecglobal.com/marine/freeman-marine/hatches/2400-series/cast-aluminum-flush-deck/)

CONSULT | CREATE | DESIGN | MANUFACTURE | DELIVER