

Standard Connector 30

Part N ^o	Description	Weight
SV1910V	Standard Connector 30	12 g

Application: An inexpensive and simple connection for profiles. The t-slot is not deformed when the joint is made, giving greater stability to the joint. At the same time, the fastener guarantees no twisting of the joined profiles.

Material: steel, zinc-plated

- Assembly:**
- Insert the standard fastener into the t-slot from the end of the profile
 - bore hole for Km 8: $\varnothing 8.5$ mm, 15 mm from the profile end, 30 mm deep
 - bore for cap screw head: $\varnothing 13$ mm, 15 mm from the profile end, 10.5 mm deep
 - Tap center hole of mating profile with an M8 thread.

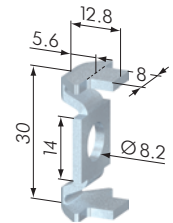
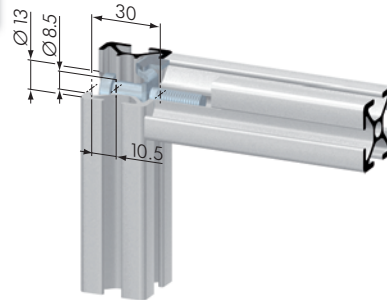
30

SV1910V
Central Fastener 20 EL / EQ

Part N ^o	Description	Weight
SV1501V	Central Fastener 20 EL	8 g
SV1500V	Central Fastener 20 EQ	8 g
SB1332	Machining Central Fastener	

Application: All-purpose universal fastener. The twist-in anchor, with an anti-twist feature, can be fixed in the profile t-slot at any point.

Material: steel, zinc-plated

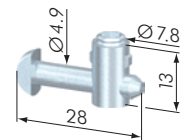
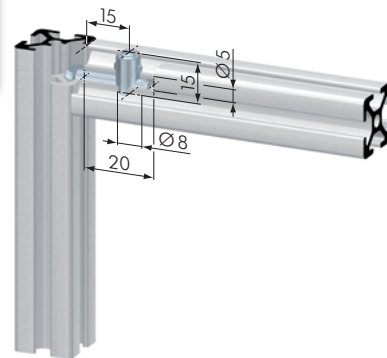
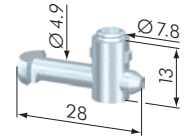
- Assembly:**
- bore hole for the barrel housing: $\varnothing 8$ mm, 15 mm from the profile end, 15 mm deep
 - bore for center hole on end of profile for anchor: $\varnothing 5$ mm, 25 mm deep

20

SV1501V

SV1500V