

# PALETTI

## Linear Slide Actuators – Belt Driven – 150 Lbs. Omega Configuration

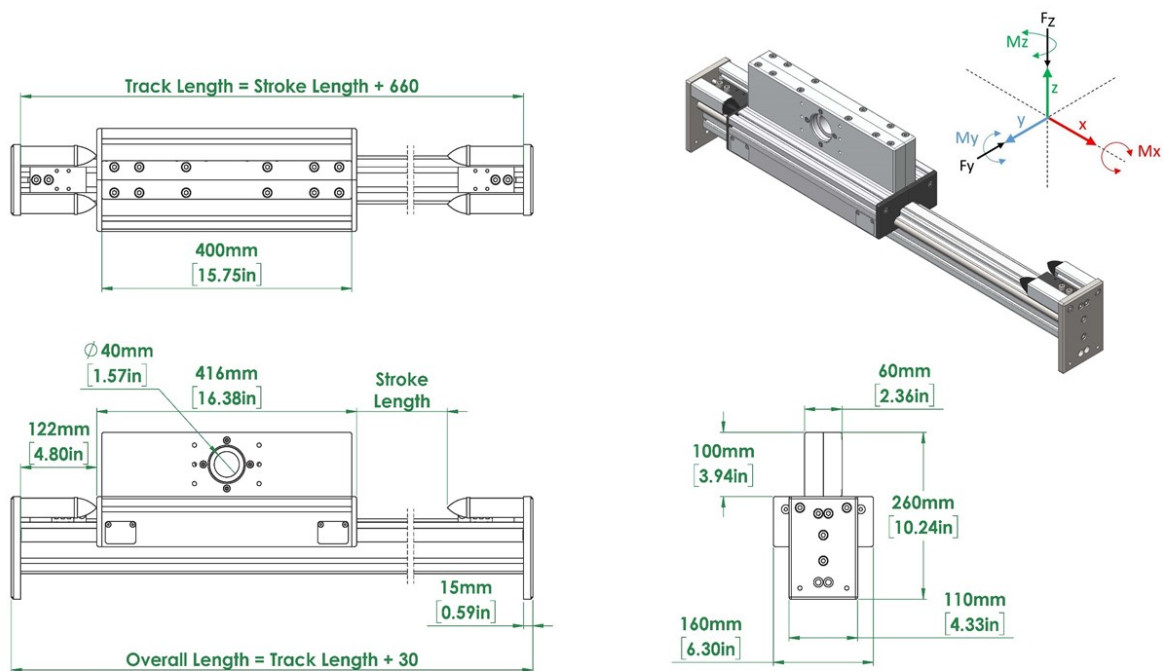

Model	Max Dynamic Load (Lb/N)	Static Axial Load (Fz)(Lb/N)	Static Radial Load (Fy)(Lb/N)	Static Moment Load (Mz)(in-lb/Nm)	Static Moment Load (My)(in-lb/Nm)	Static Moment Load (Mx)(in-lb/Nm)
BTRO150	150 / 667	450 / 2000	875 / 3900	5797 / 655	3142 / 355	531 / 60
	Max Speed	Pulley Pitch Diameter (mm)	Pulley Torque (in-lb/Nm)	Belt Tensile Strength (Lb/N)	Elongation	Carriage Weight (kg)
	8 m/s	89.13	619 / 70	675 / 3000	.1% @ 102 N	15.5

Please Note - the numbers in these drawings and tables represent performance parameters for our standard model. We can always customize a model more specifically to your application. Actual performance will vary pending motor/gearing selection.

When high speeds and long travel distances (20+feet) are required, Paletti toothed belt driven linear roller-slide actuator systems are ideally suited for your material handling and positioning tasks. Toothed belt driven linear systems are easy to incorporate into single or multi axis applications and offer long service life with minimal noise and maintenance.

The Omega configuration shown above is most commonly used in applications where it is desirable for the motorized carriage position to be fixed, and the rail then translates.

Some additional product advantages with Paletti belt driven slide actuators:

- ◆ AT10 tooth profile belts with easy tensioning and zero backlash
- ◆ Multiple belt material options – pending application needs
- ◆ End of carriage covers with lubrication ports and brushes to help keep the rails clean
- ◆ Easy to perform maintenance – without removal from the machine
- ◆ Single piece carriage and rail construction, with corrosion resistant component options

Since our actuators, aluminum framing, and conveyors all use the same 8mm T-Slot, it is very easy for us to configure and/or build an entire system or machine base.

**We believe in being accessible, so contact us today to learn more!**