

# PALETTI

## Linear Slide Actuators – Ball Screw Driven – 350 Lbs. Upright Configuration

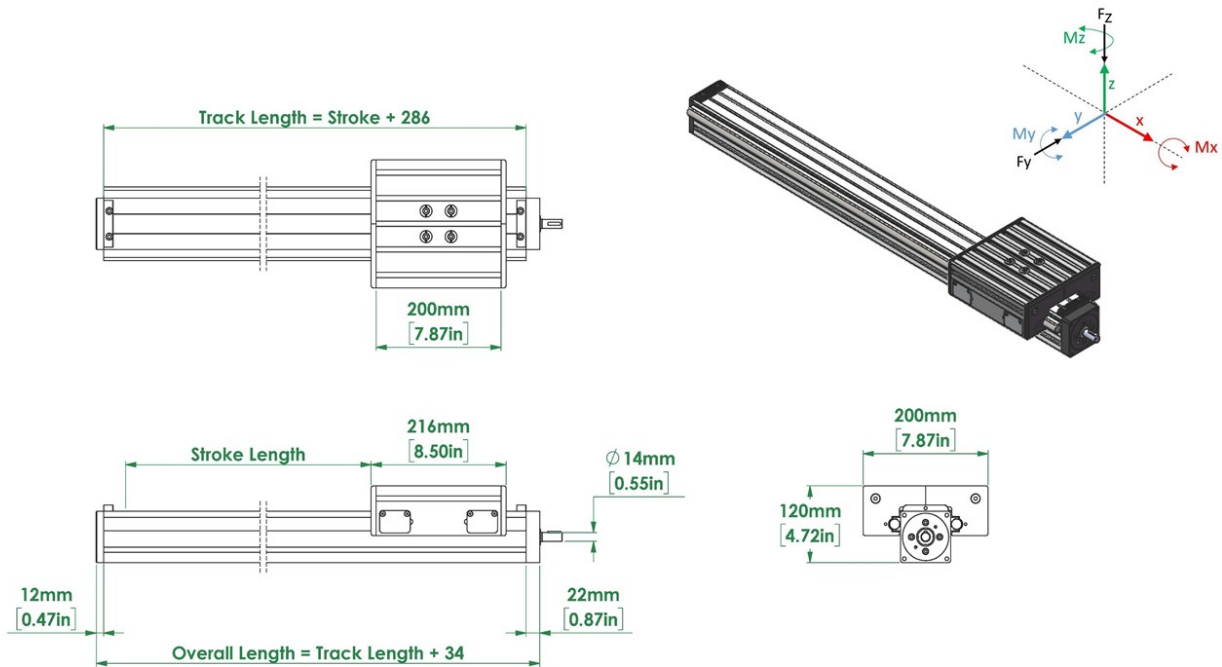

Model	Max Dynamic Load (Lb/N)	Static Axial Load (Fz)(Lb/N)	Static Radial Load (Fy)(Lb/N)	Static Moment Load (Mz)(in-lb/Nm)	Static Moment Load (My)(in-lb/Nm)	Static Moment Load (Mx)(in-lb/Nm)
BARU350G	350 / 1555	450 / 2000	875 / 3900	2390 / 270	1239 / 140	885 / 100
	Max Speed	Torque to Raise 1kN (in-lb/Nm)	Screw Diameter and Pitch (mm)	Screw and Nut Backlash (mm)	Movement Efficiency	Carriage Weight (kg)
	0.635 m/s - 25 in/s	31.33 / 3.54	20 x 20	0.041	90%	6.4

Please Note - the numbers in these drawings and tables represent performance parameters for our standard model. We can always customize a model more specifically to your application. Actual performance will vary pending motor/gearing selection.

Paletti ball screw driven, roller-slide actuators are ideally suited for your material handling and positioning tasks. Our screw actuators are easy to incorporate into single or multi axis applications, and offer long service life with minimal noise and maintenance. All Paletti screw actuators have the classic fixed (double bearing) – float (single bearing) supports, custom bearing supports can be accommodated.

Our 20mm x 20mm ball screw slide actuators – are highly efficient, capable of high speeds, and can offer long life spans and high duty cycles. The torque requirements for these models can be high.

Some additional product advantages with Paletti ball screw driven slide actuators:

- ◆ Guided motion – all in one unit
- ◆ External to the rail carriage configuration with hardened and ground rollers and rails
- ◆ Lead error held to +/- 52µm / 300mm
- ◆ End of carriage covers with lubrication ports and brushes to help keep the rails clean
- ◆ Single piece carriage and rail construction, with corrosion resistant component options

Since our actuators, aluminum framing, and conveyors all use the same 8mm T-Slot, it is very easy for us to configure and/or build an entire system or machine base.

**We believe in being accessible, so contact us today to learn more!**