

PALETTI

PRECISE, DURABLE, INDIVIDUAL

ALUMINIUM PROFILES AND AUTOMATION SYSTEM SOLUTIONS FOR INDUSTRY

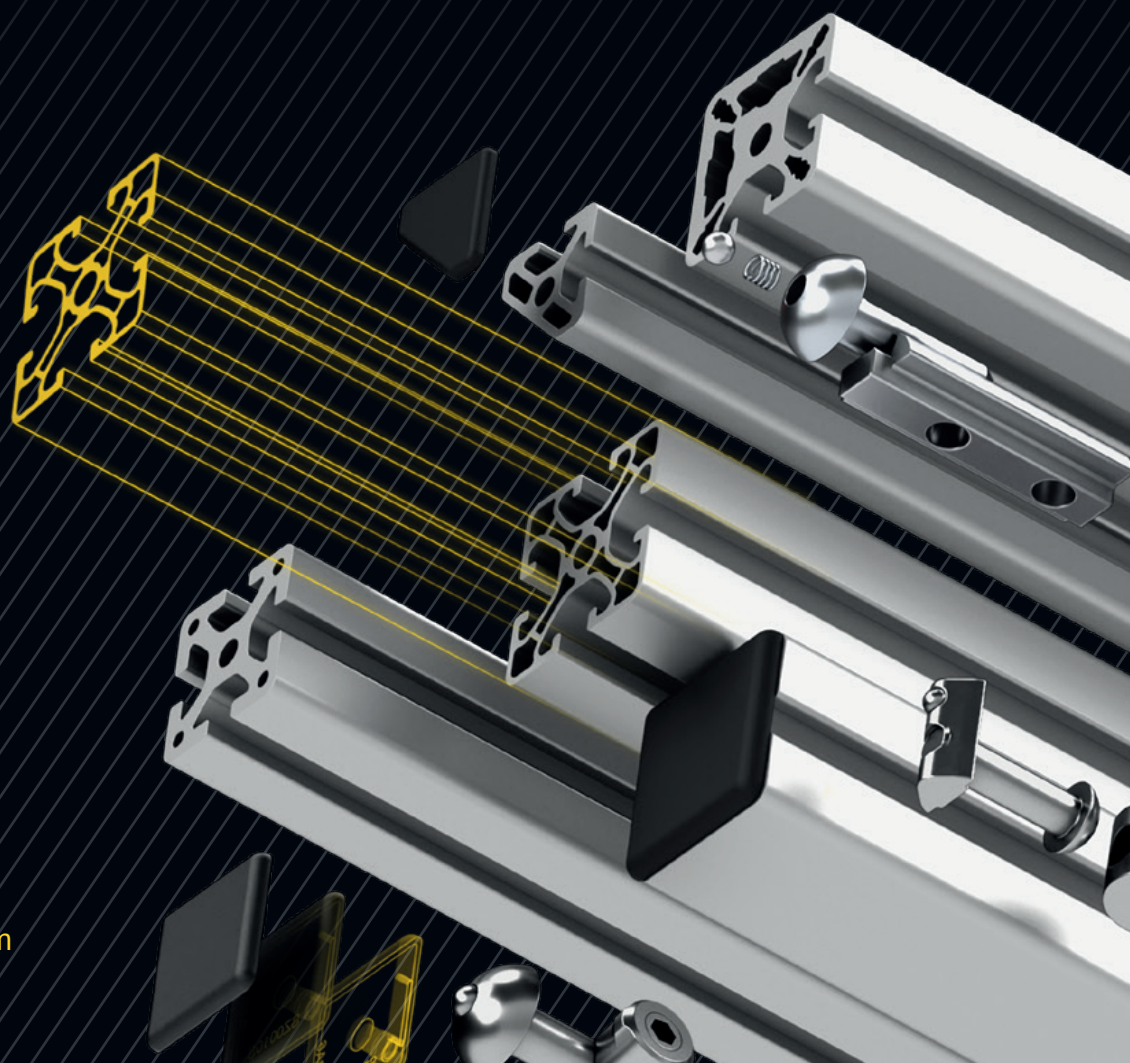

www.paletti-group.com

ABOUT US

ABOUT THE PALETTI GROUP

Everything's perfect with Paletti – when the company was founded, this statement was our namesake. And as casual as the saying may seem, it reflects exactly what our customers can expect: Anyone who chooses aluminium profiles or system solutions from Paletti always makes a good choice.



WHAT WE DO

We manufacture innovative production equipment that supports flexibility and efficiency in mechanical and automation engineering. Our focus is on the development and production of a modular profile system made of aluminium. This forms the basis for individual customer solutions.



WHAT SERVICE WE OFFER

We offer a professional all-round service. From planning to development and production to the installation in the plant. Our experts support our customers in every step of the process.



HOW WE WORK

We are equipped with the most modern CNC-machines and testing rooms. Our qualified team of engineers and specialists works on the basis of CAD/CAM and supports our customers with creativity, flexibility and commitment.



WHAT ADVANTAGES WE HAVE

We are only satisfied when our customers are. And to achieve this, we place particular emphasis on: highest quality, absolute precision work, an optimal price/performance ratio and timely order processing

THE APPROPRIATE SOLUTION

THE FIELDS OF APPLICATION

With our aluminium profiles and system solutions, we can be found in – almost – all areas of application. Industrial Machinery – Automation – Metrology – Material Handling – Conveyor technology – Laser safety enclosures – Cleanroom solutions – Protection and Separating Wall System – Laboratories – Medical technology – Industry – Private Applications. Wherever aluminium profiles can support the work of our customers, we demonstrate that you can rely on our profiles all around.



IT STARTS WITH A STRONG BASE

STANDARD ALUMINIUM PROFILES

Aluminium profiles are used in almost all industries. That's why at Paletti you will find a wide range of extruded aluminium profiles that impress with the highest precision, durability and sustainability and that can be used in a wide variety of industries, and applications.

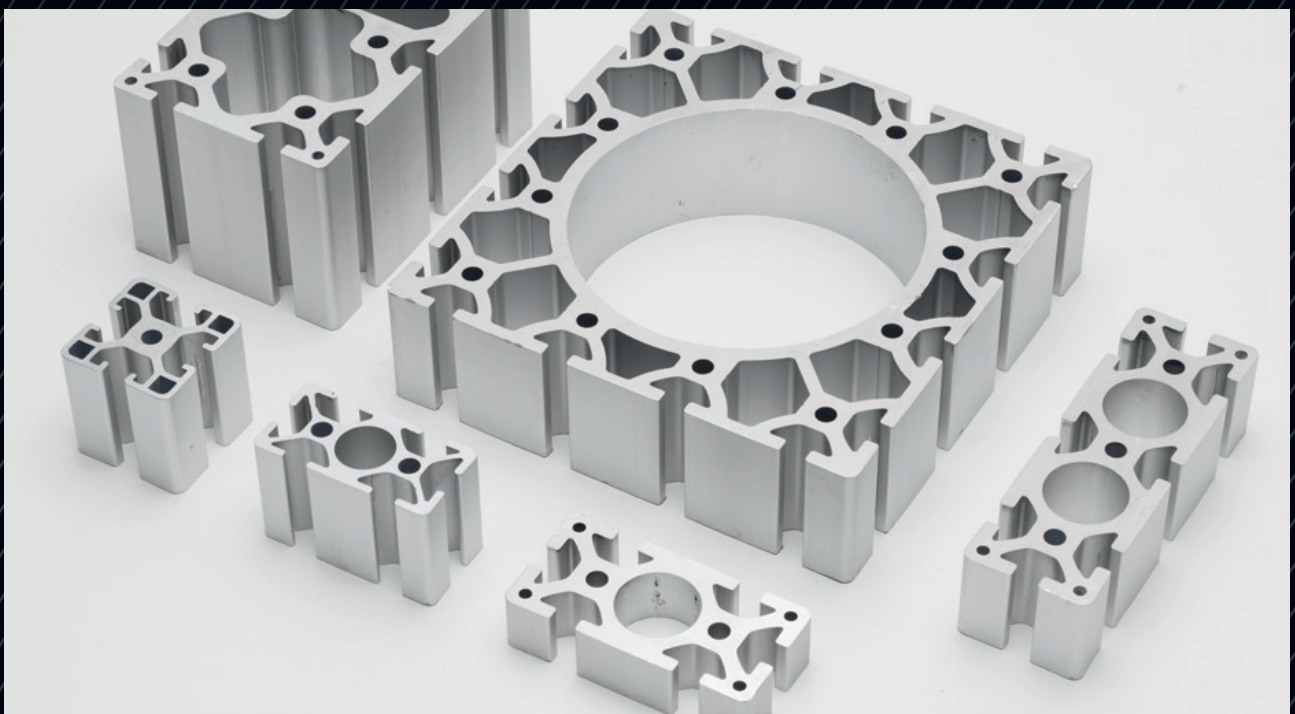

UNIVERSAL APPLICATIONS

PROFILE SYSTEMS

The solution fits the need, which is why Paletti uses the highest quality aluminium profiles to ensure the best solution for your application.

Paletti's aluminium profile systems were developed as a modular profile system to meet the requirements of mechanical and automation engineering. As a result, they are compatible with each other, particularly torsion-resistant, versatile and have become indispensable in a wide range of sectors and industries. They come in different series, dimensions and thicknesses (geometries). They are easy to assemble and can be easily combined with other

Paletti assemblies, e.g. laser safety enclosures, linear systems, conveyor and workstation systems. All installed elements are reusable, protected with an anodized layer against environmental influences such as moisture, air and light, and thus sustainable in their use. Or in other words: Our aluminium profile systems deliver what Paletti promises.

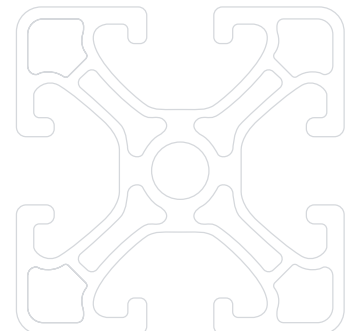

PALETTI ALUMINIUM PROFILE

OUR SERIES

Our profile series are designed with an 8 mm t-slot geometry. With the exception of profile series 20 with a 5 mm t-slot geometry.

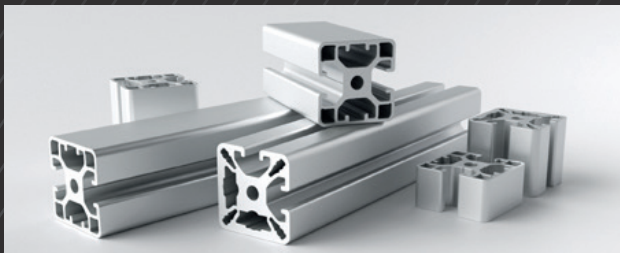

PROFILES 40



PROFILES 30



PROFILES 20



INCH PROFILES

PALETTI ALUMINIUM PROFILES

FASTENERS AND SERVICE



FASTENERS

With the right connection technology, our aluminium profiles can be combined precisely and with high stability. It's easily customizable for any application. It is as simple as that!

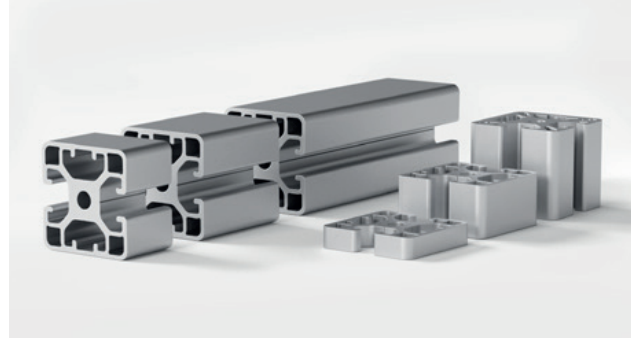

MACHINING OF PROFILES AND COMPONENTS

We are also the specialists when it comes to machining aluminium profiles. With our CNC-controlled machining centers we mill, saw or drill the aluminium profile if required.



PROFILES FOR PROTECTION AND SEPARATION SYSTEMS

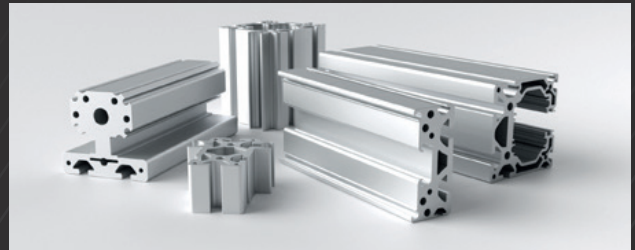

PROFILES FOR LINEAR TECHNOLOGY



PROFILES FOR LASER SAFETY ENCLOSURES

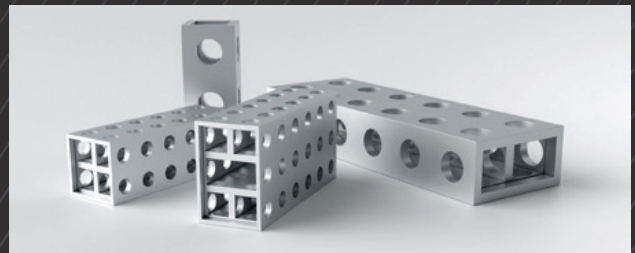

PRECISION PROFILES



SPECIAL PROFILES



You can find our full range of profiles here.

PALETTI ALUMINIUM PROFILES

BOUNDLESS DIVERSITY

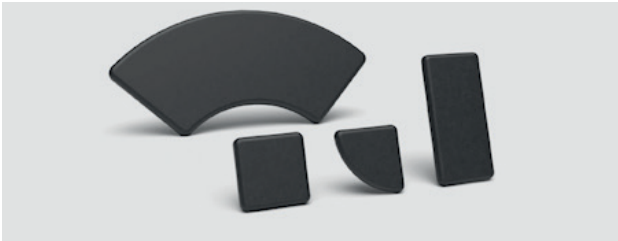

COVER CAPS



FOOT, FLOOR AND PORTAL PLATES



CABLE DUCTS + COVERS



PNEUMATIC CONNECTOR

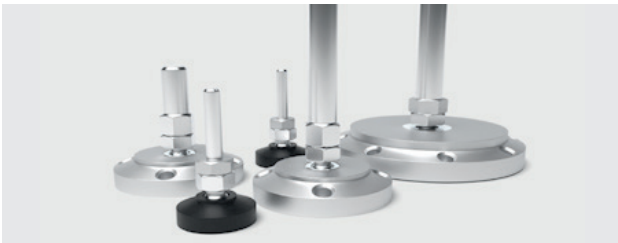

ADJUSTABLE FEET



ANGLE FEET



HINGES AND JOINTS



WHEELS + ROLLERS

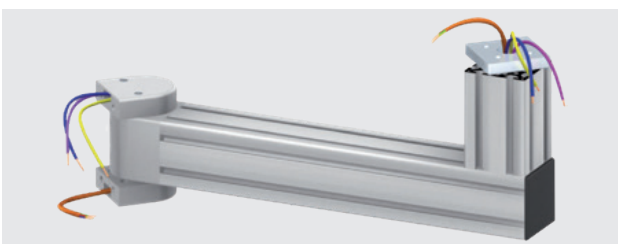

MONITOR / SCREEN HOLDER

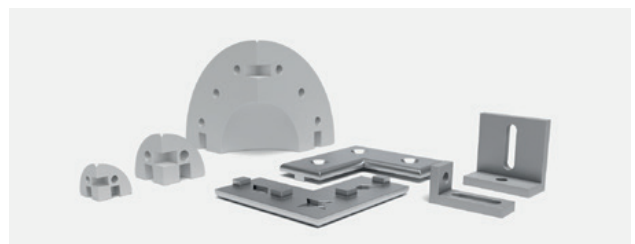

MOUNTING BRACKET, ROUND CORNER AND KNOT METALSHEETS

SAFELY SEPARATED

PROTECTION AND SEPARATING WALL SYSTEMS

For more than 25 years, Paletti has been producing a wide variety of protective and safety guarding for people and machines.

Regardless of whether people need to be protected or demarcated from machines, work or office areas – when

it comes to protective and partition walls, we are exactly the right contact. For more than 25 years, Paletti has been producing a wide variety of safety devices – from fencing with wire mesh to protection systems with panel elements to complete machine enclosures.

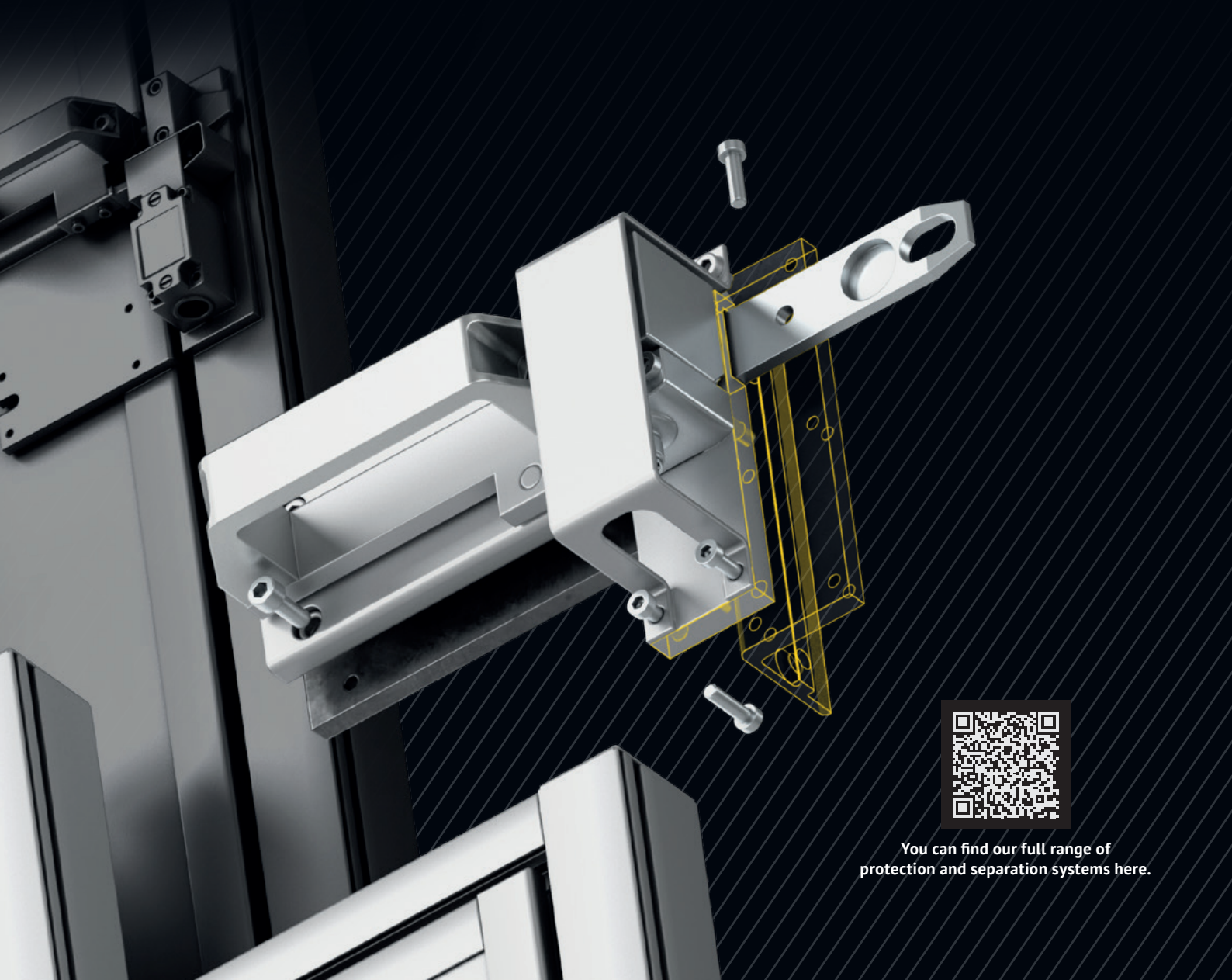

You can find our full range of protection and separation systems here.

PROTECTION AND SEPARATING WALL SYSTEMS

PRECISE PROTECTION



PROTECTIVE FENCES

With our flexible protective fence system, you can build a custom-fit, complete security system.



SEPARATING WALLS

Perfect protection for people and consistent safeguarding of machines – our partition wall systems are based on the Paletti aluminium profiles and can therefore be easily extended or modified as required.



SAFEGUARDINGS

Paletti offers guards that are mounted directly on your machine.

INDIVIDUAL, FLEXIBLE, ERGONOMIC

ASSEMBLY AND WORKSTATION SYSTEMS

Paletti offers a wide range of workstations for all work requirements – from assembly workstations and packing tables to laboratory or office workstations. Each workstation is tailored to the customer's needs for more efficiency at work, making them unique and ergonomic.

From design and assembly to commissioning, we work closely with you to fulfill the customer's requirements. Thanks to our modular aluminium profile system, we can easily expand, rebuild and add to all designs at any time.

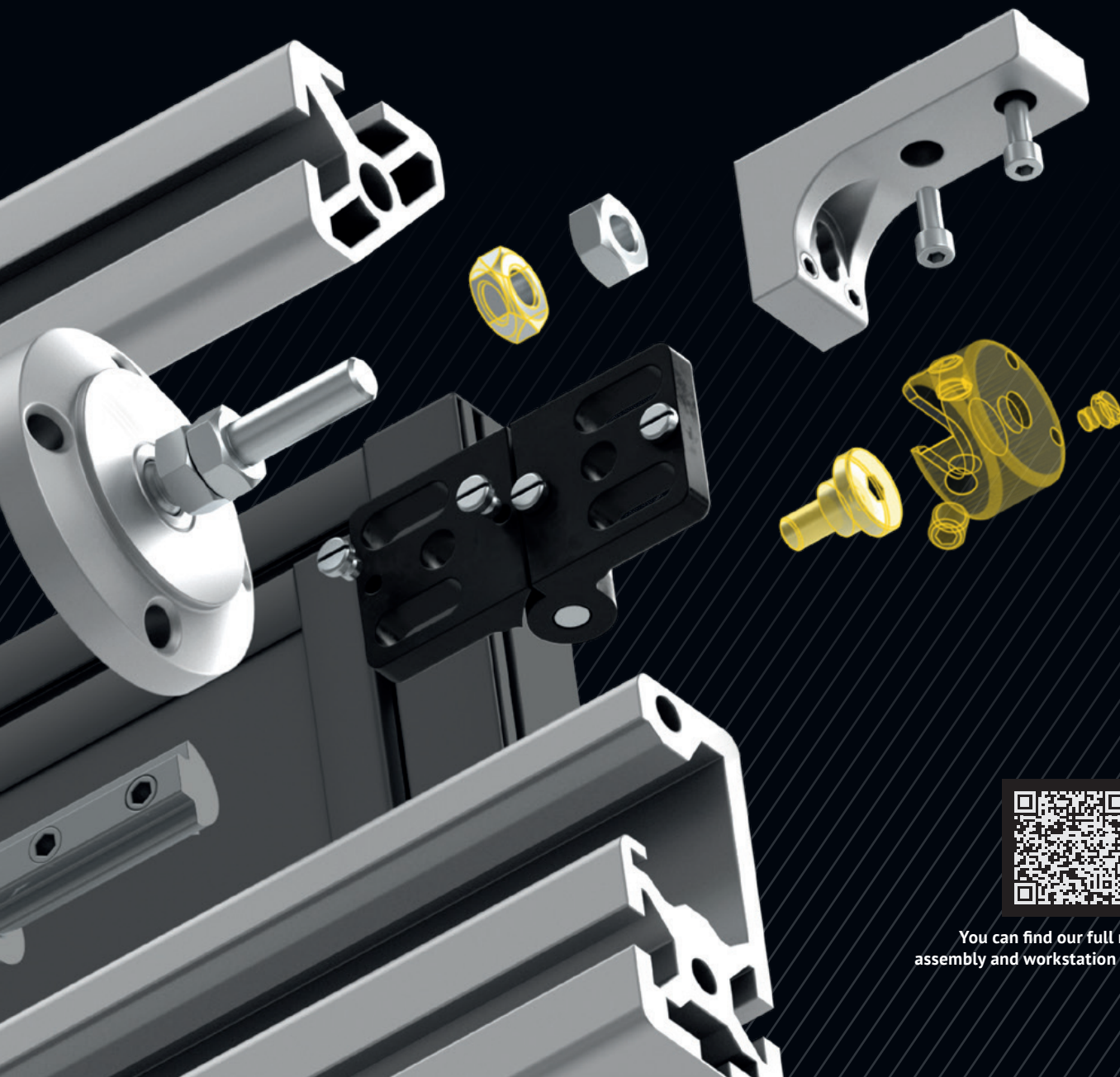

You can find our full range of
assembly and workstation systems here.

ALUMINIUM PROFILE-MODULAR SYSTEM

ASSEMBLY WORKSTATIONS & WORKBENCHES

The requirements for assembly and testing workstations or workbenches are complex due to the wide variety of work processes and changing workplaces. With our modular aluminium profile system, we design the right solution. Workstations can be individual, ergonomic or interlinked and are durable and individually tailored to you. A wide range of options such as worktops, drawers, surface elements, ESD accessories, container holders, workstation lights, power outlets or media channels can be mounted to adapt the workstations and workplaces to current and future production processes using our accessories.



ALUMINIUM PROFILE-MODULAR SYSTEM

CUSTOM FURNITURE AND DISPLAY TABLES

The individual office desks in a wood/aluminium combination can be designed as individual or group workplace solutions. Paletti tables can also be made from closed profiles, with additional chrome plating options and glass work surfaces. The open chambers of the table legs allow connection cables to be routed safely and cleanly. The open grooves on the profiles can also be closed by cover profiles. Thanks to the modular aluminium profile system and a wide variety of processing and supplemental options, we leave nothing to be desired. We design your co-working space with you.



MATERIAL IN MOTION

CONVEYOR TECHNOLOGY

Our conveyor systems are durable, flexible and always precisely tailored to our customer's needs. You can rely on us. Thanks to our extensive line of modular aluminium profiles, Paletti's conveyor systems are durable, flexible, sustainable and always configured to your exact needs.

We offer customers an extensive range of fully customi-

zable solutions that are easily assembled using Paletti's proven connection and clip technology. Similarly, our T-slot construction provides simple mounting options that make it easy to customize and add accessories. As a result, our conveyor systems can be quickly disassembled, replaced, and expanded upon to meet your evolving material handling needs.

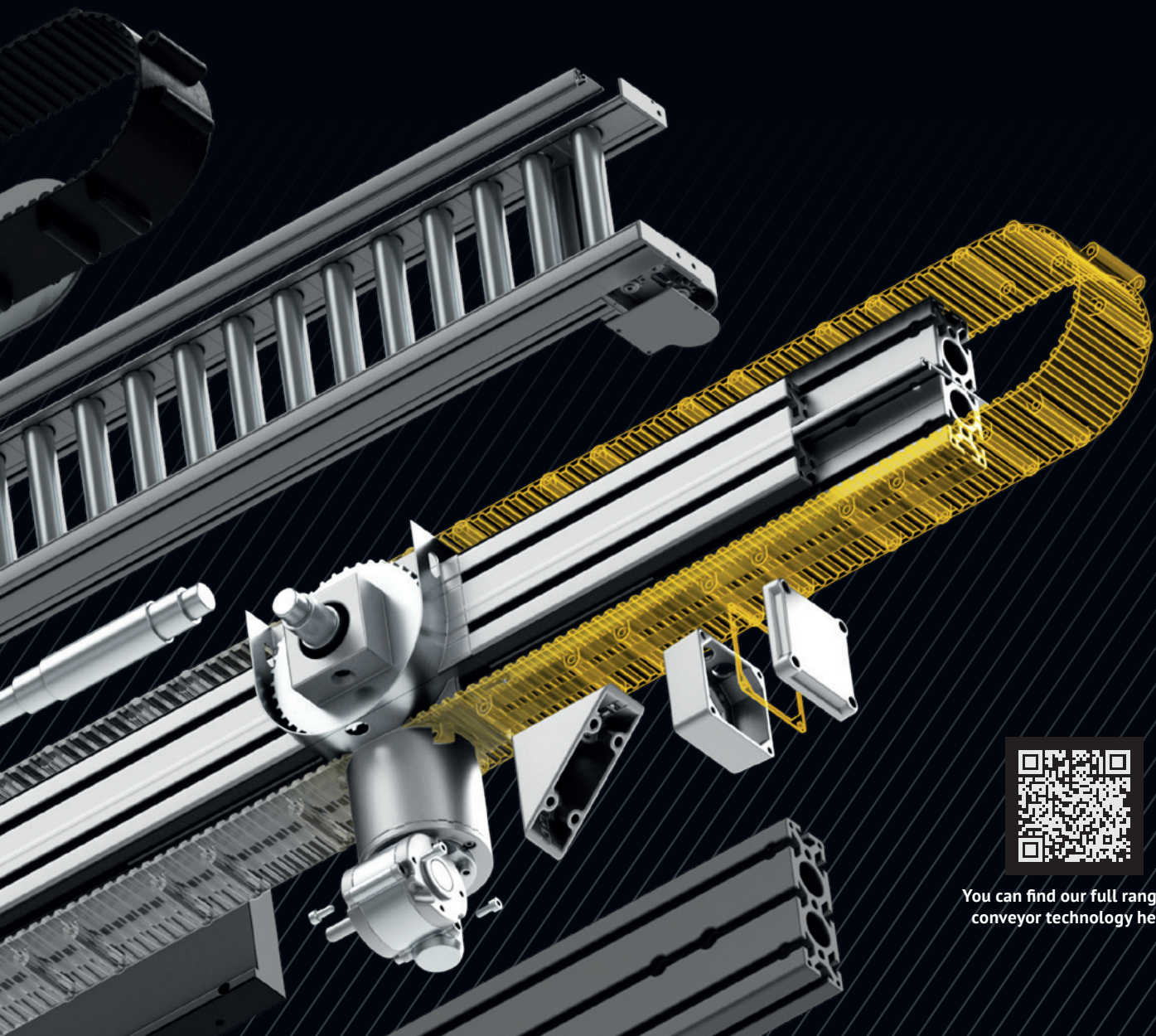

You can find our full range of conveyor technology here.

CONVEYOR TECHNOLOGY

MATERIAL IN MOTION



FLAT BELT CONVEYOR

The belt conveyor framework is constructed from our standard profiles Raster 40. The wood or metal sheet is used to support the conveyor belt. The conveyor belts are purchased to customer requirements.

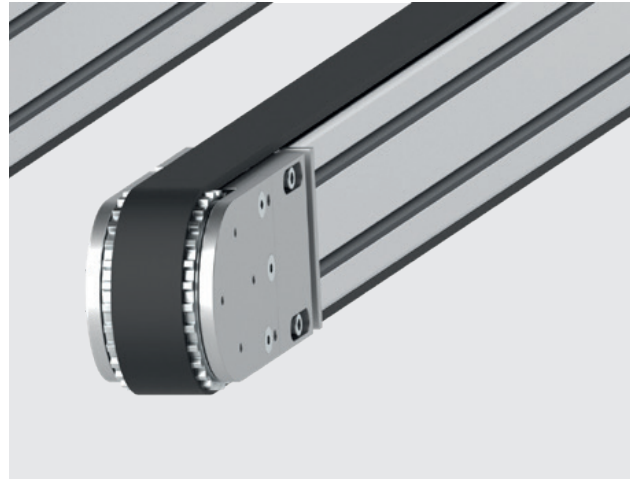

TIMING BELT CONVEYOR

Paletti's standard Raster 40 profiles form the robust frame of the timing belt conveyors. The conveyors have a selection of drive units available to suit most needs. Power is transmitted via a gearbox, with the conveyor belt being tensioned by two deflection units.



ROLLER CONVEYOR

For driven roller conveyors, Paletti manufactures a special profile consisting of four individual profiles for easy assembly and disassembly. For non-driven roller conveyors, the standard profile is used. In conjunction with some additional systems, any conveyor or transport job can be accomplished.

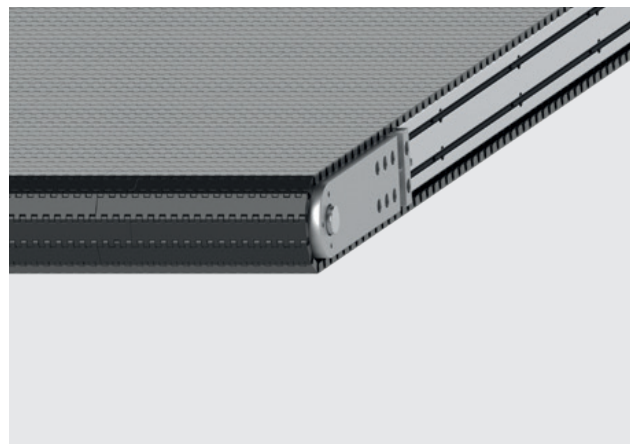

PLASTIC LINK CHAIN CONVEYOR

Conveyor belts with link chains – also known as modular belts – are used in particular for the transport of unit loads, which sometimes have to go around bends. The basis for this are again standard profiles 40 as well as the proven drive components.

THERE IS MOVEMENT IN HERE

LINEAR TECHNOLOGY

When reliable and precise movements are required, Paletti offers a range of linear motion systems that will fit your needs. Our linear actuator product line includes timing belt drives, recirculating ball screw or trapezoidal drives, and non-driven linear slides. Paletti's linear actuators can be adapted to fit individual customer requirements, whether as a single linear axis, or a multi-axis gantry system additional with a combination of electric motors and gearbox units.

Based on our versatile modular profile system and our CNC machining capabilities, we design your linear system according to your needs and requirements.

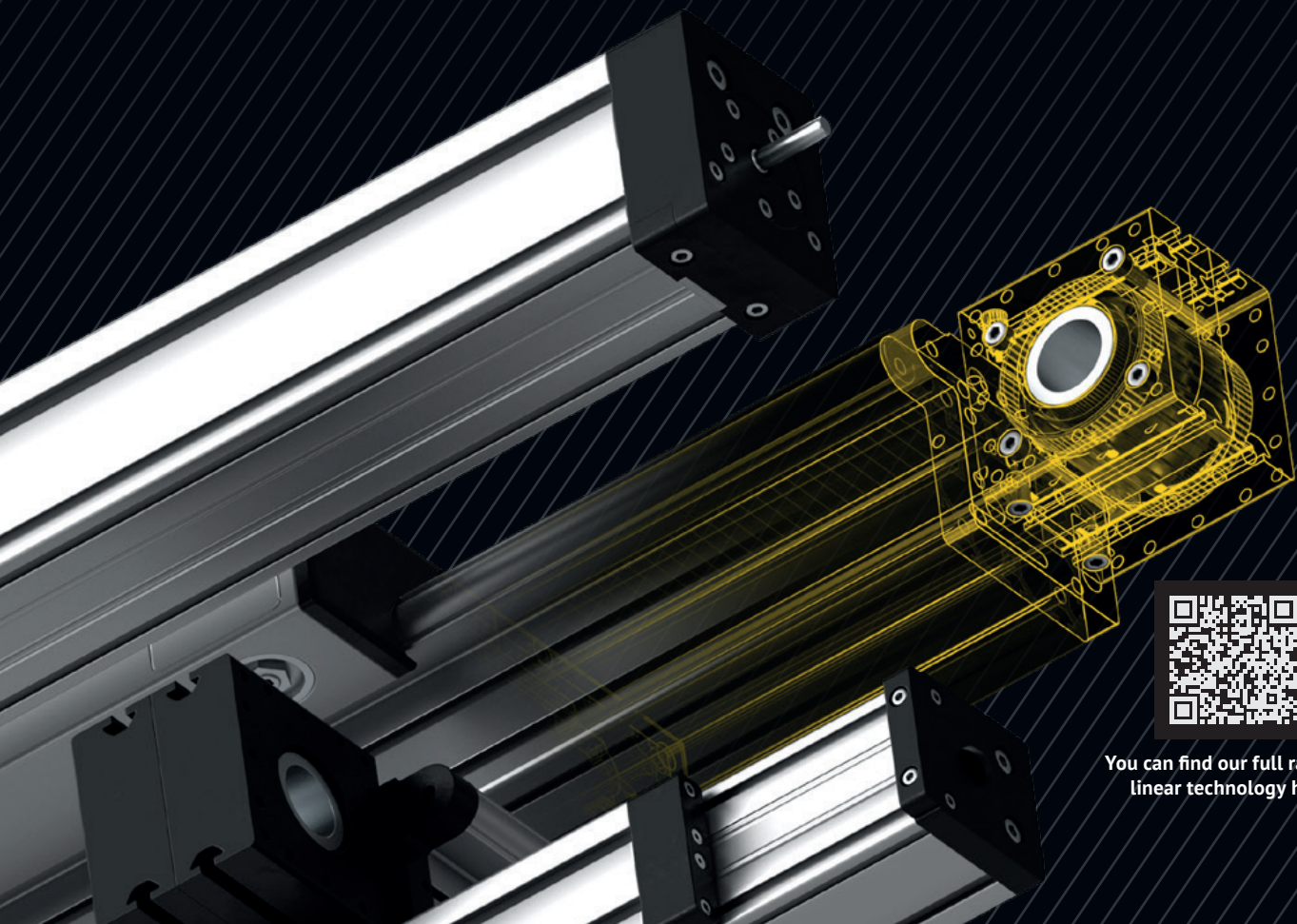

You can find our full range of linear technology here.

LINEAR TECHNOLOGY

FLEXIBLE AND RELIABLE



INTERNAL DOUBLE GUIDE WITH TIMING BELT DRIVE

Designed for high forces and fast speeds. To protect the internal guides against dirt, the profile is closed with a cover strip.

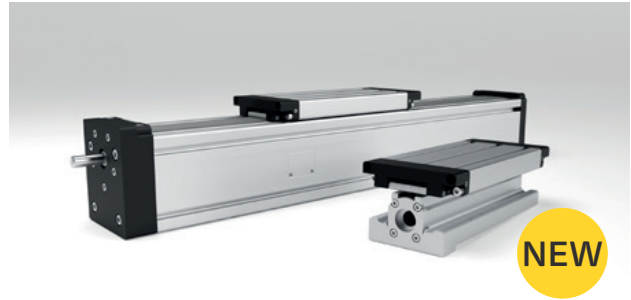

INTERNAL DOUBLE GUIDE WITH SPINDLE DRIVE

Designed for high forces and high positioning accuracy. To protect the internal guides against dirt, the profile is closed with a cover strip.

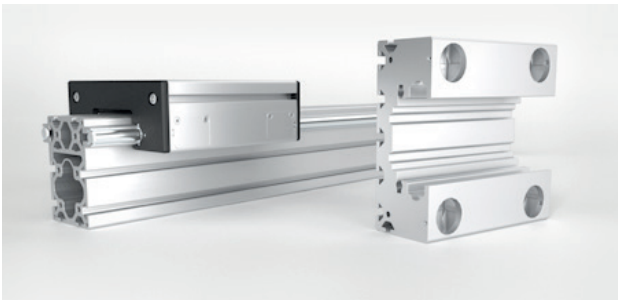

LINEAR GUIDE SYSTEMS

Linear systems for carrying load for manual positioning or parallel guidance.



TIMING BELT DRIVEN LINEAR SYSTEMS

Linear systems for long strokes and high speeds. Paletti also offers Omega drives for Z-axis pick and placement needs.

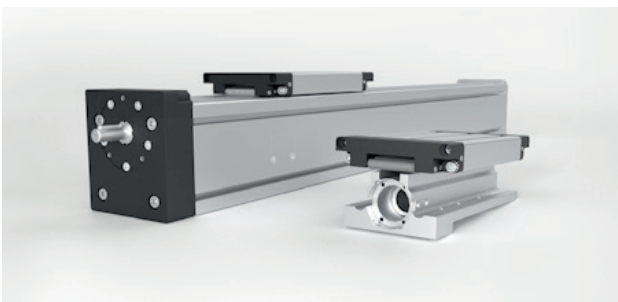

BALL SCREW AND TRAPEZOIDAL SCREW DRIVEN LINEAR SYSTEMS

Linear systems ideally suited for larger forces and high positioning accuracy.

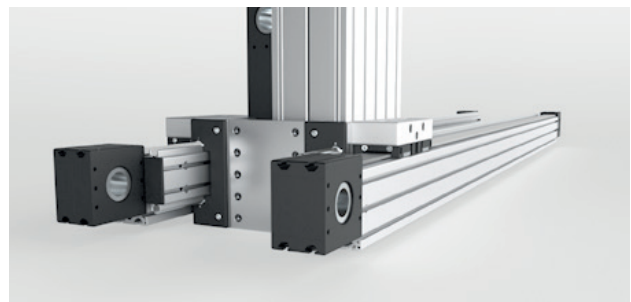

MULTI-AXIS GANTRY SYSTEMS

By combining individual linear axis our engineers are able to produce complex multi-axis gantry systems according to the customer's requirements.

SAFE IS SAFE

TESTING TECHNOLOGY

With a targeted policy of expansion, the Paletti Group expands its know-how in the field of test benches and will in future handle this area completely in-house.

A major focus of the test benches is furniture testing, where we now supply everything from a single source, from planning and execution to installation and training at the customer's premises. Through the constant further development of the test benches together with the testing institutes and manufacturers, our specialists achieve the optimal adaptations to the demanding requirements of the testing task.

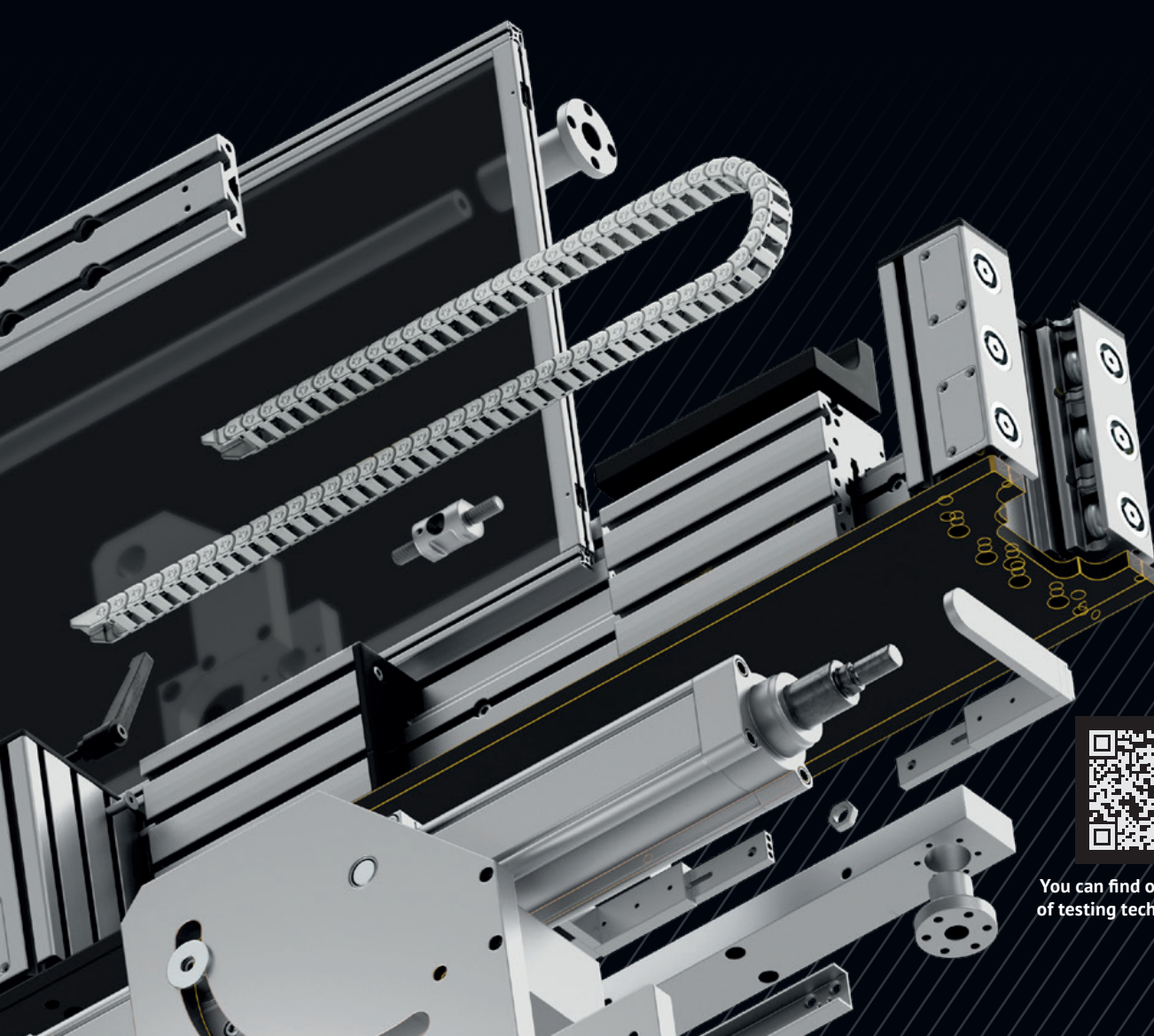

You can find our full range of testing technology here.

TEST STAND TECHNOLOGY

CREATIVE, INDIVIDUAL AND RELIABLE

For many years, Paletti has been a reliable and innovative partner for test engineering requirements with its extensive range of aluminum profiles. Thanks to this experience, all test stands are delivered with the well-known quality, technical perfection and powerful software for Windows PCs.

All test sequences and control parameters are recorded and monitored in real time. The predefined test sequences

can be parameterised and described via the test item management. By using Ethernet, you can be sure that you are using state-of-the-art technology.

The integrated transducers and parameter management offer you the possibility to calibrate and adjust all actuators and sensors conveniently. Modern tools such as curve recorders, auto-calibration and trend analysis are available for this purpose.

TEST BENCHES FOR THE FURNITURE INDUSTRY

- ▶ Furniture fittings testing
- ▶ Seat and chair testing
- ▶ Table and mattress testing
- ▶ Armrest testing

DEVELOPMENT AND COMPONENT TEST BENCHES

- ▶ Endurance testing
- ▶ Vibration- and production testing
- ▶ 20 t test press

TEST BENCHES FOR TEST INSTITUTES AND MANUFACTURERS

- ▶ Multicontour testing
- ▶ Linear axis testing
- ▶ Bending-change testing
- ▶ Side-to-side testing
- ▶ Displacement testing

Double folding hinge test bench for furniture

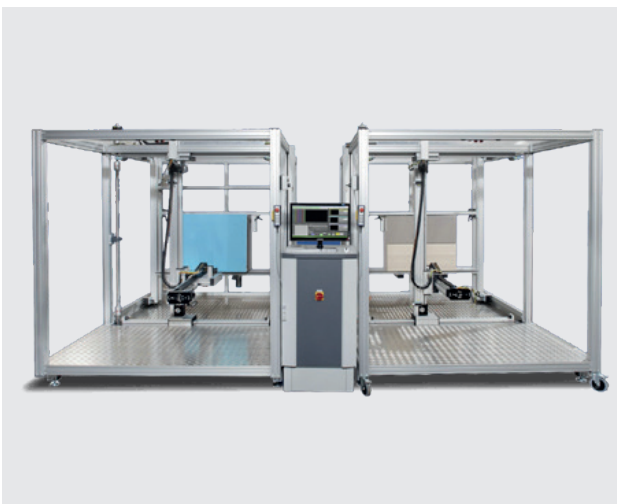

Bending change test stand with servo axes



ON THE SAFE SIDE

LASER SAFETY ENCLOSURES MADE FROM ALUMINIUM PROFILES

Paletti's self-supporting laser enclosures are suitable for applications with high-power lasers up to 8 kW and higher and have a worldwide patented system design. They fulfill the safety and quality requirements per ANSI and EN standards, and are tested and certified according to DIN EN 60825 "Laser equipment" and DIN EN ISO 11553-1:2005 "Laser processing machines".

The modular structure of our aluminium profiles makes it possible to create protective enclosures of almost any

shape and size. Thanks to our patented wall structure and flexible corner system, radii or corners can also be created outside 90°. Paletti's standard 40 series t-slotted profiles can be easily integrated into our safety enclosures thanks to the common 8mm t-slot in the profiles.

By the way: Our protective enclosures can also be configured as soundproof enclosures by adding sound-absorbing panels.

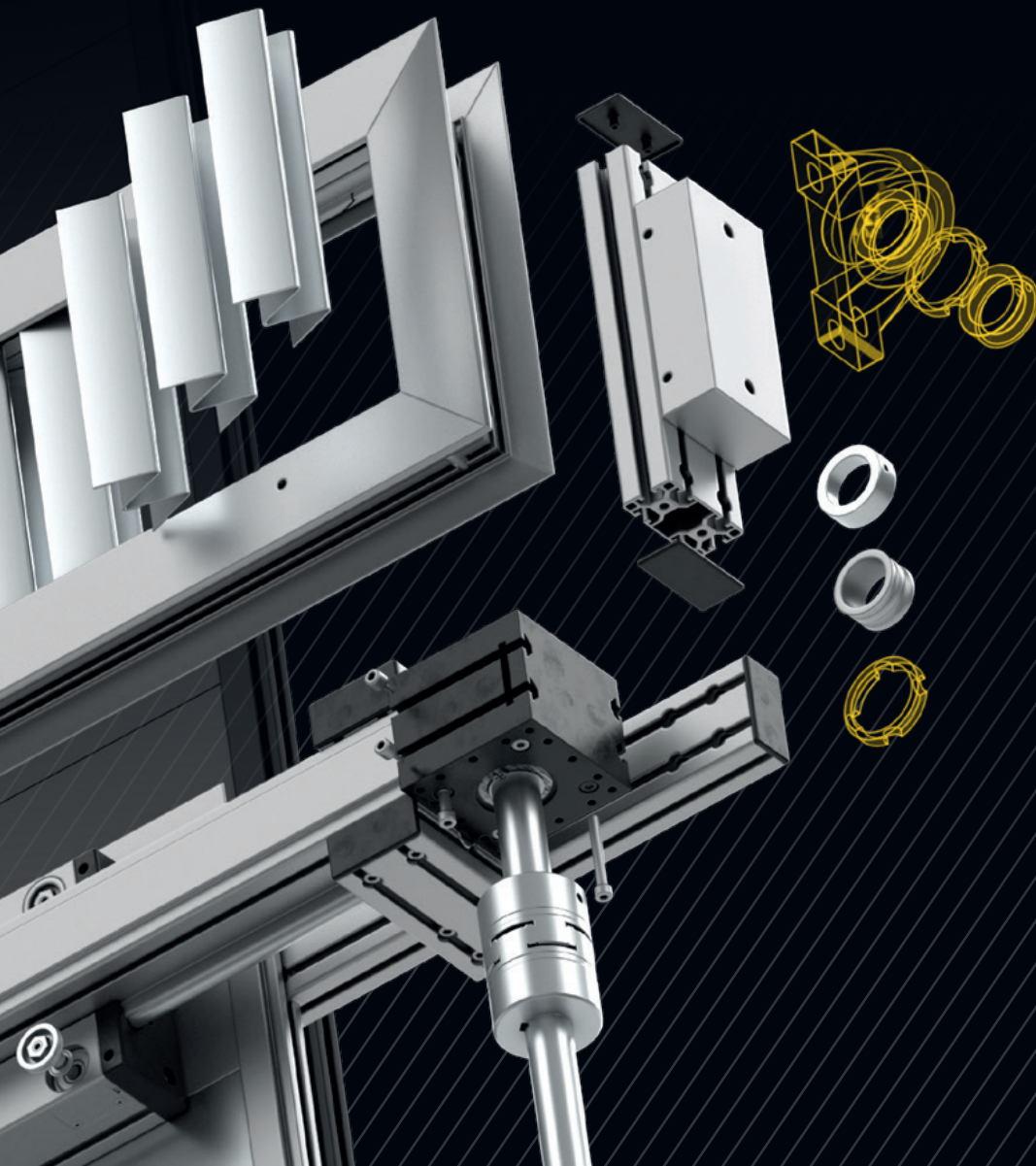

You can find our full range of laser safety enclosures [here](#).

LASER SAFETY ENCLOSURES

PROFILES WITH SAFETY REQUIREMENTS

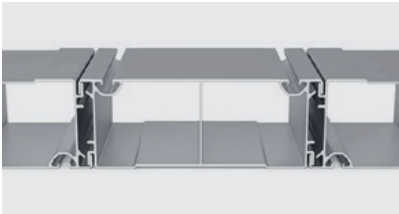

WALL PROFILES

- ▶ Ideal, interlocking labyrinth system
- ▶ Double-walled structure
- ▶ 8 mm t-slot which is compatible to 40 mm profile series
- ▶ Light tight
- ▶ Protection against laser radiation up to 4 kW cw-Nd-YAG disk

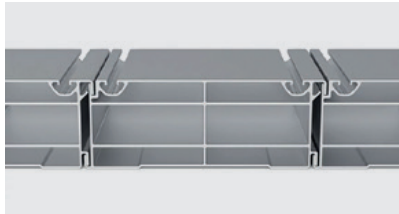

WALL PROFILES – FOCUS AREA DESIGN

- ▶ Ideal, interlocking labyrinth system
- ▶ Four-walled structure for higher power laser applications
- ▶ 8 mm t-slot which is compatible to 40 mm profile series
- ▶ Light tight
- ▶ Protection against laser radiation up to 6 / 8 kW cw-Nd-YAG

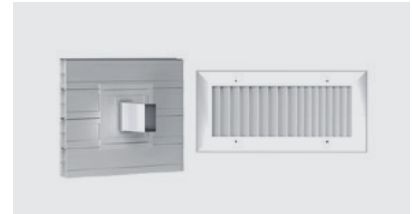

ACCESSORIES

In addition, we supply all the accessory components needed for a safe and functional booth, such as laser safe air vents, cable and fiber optic entries, pipe bushings, fire suppression, etc.

LASER SAFETY ENCLOSURES

OPTIMAL ACCESS

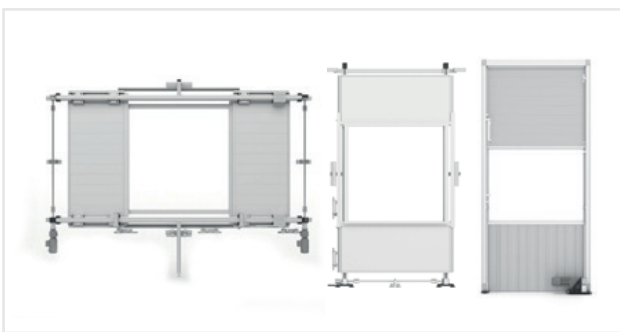

PROCESS DOORS, VERTICAL DOORS, SLIDING DOORS & TURNTABLE DOORS

Along with the laser safety enclosure, we offer high speed vertical process gates, lifting gates and sliding process gates that are optimally tailored to the enclosure.



MAINTENANCE AND ACCESS DOORS

Paletti also produces custom-fit doors for personnel who work at and in the laser safety enclosures, or have to carry out maintenance tasks.

IF IT CAN NOT BE ACCURATE ENOUGH

PRECISION TECHNOLOGY

We develop and manufacture a kit of aluminium precision profiles, which is used to create measuring fixtures, master jigs, inspection and testing fixtures, or base frames for cubbies and gauges. For this purpose, there is a wide range of accessories for tuning, adjusting or even

changing the pickup points. The system is designed to be reproducibly disassembled and assembled at any time.

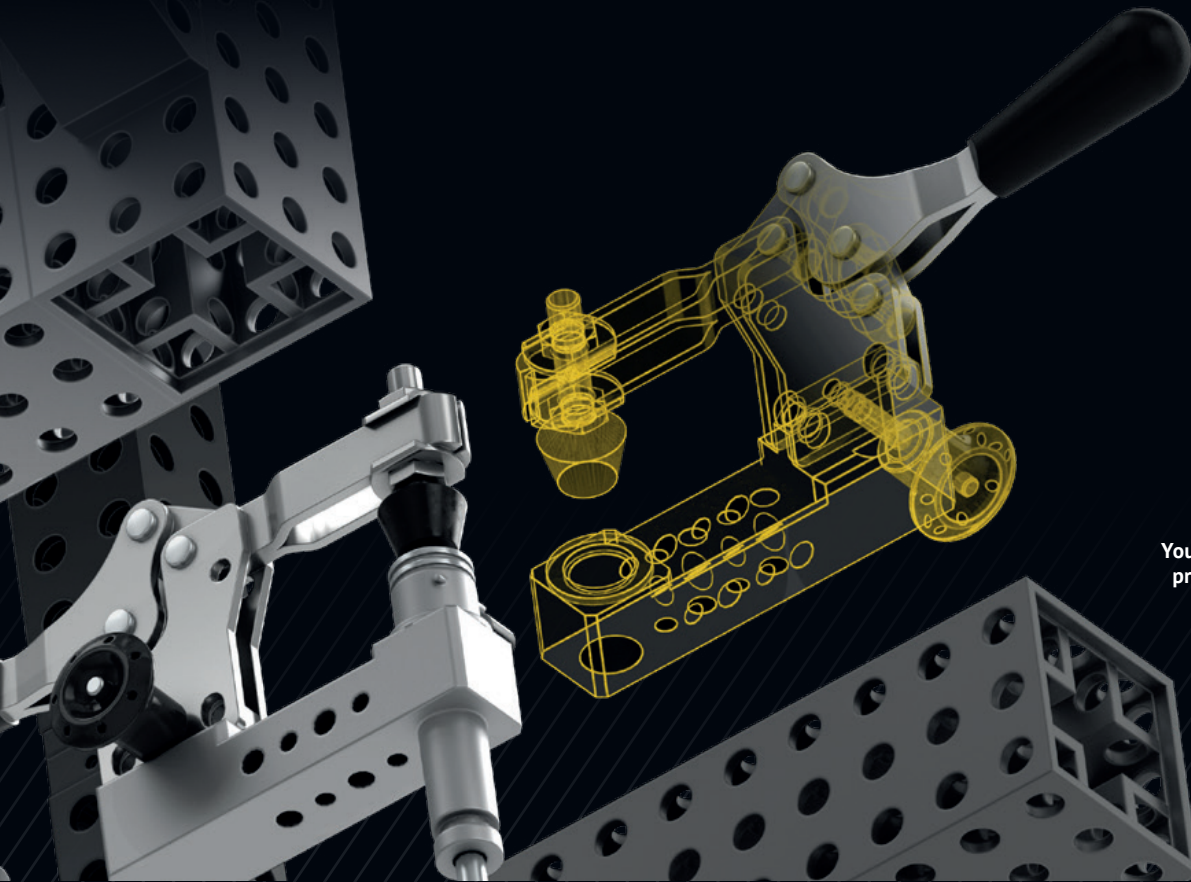

You can find our full range of precision technology here.

THE BASIS OF OUR PRECISION ENGINEERING

SYSTEM STRUCTURE

- ▶ precise aluminium profiles in grid 25, 40, 50
- ▶ high-strength profiles due to special alloys
- ▶ torsion-resistant system
- ▶ Profiles completely equipped with grid holes
- ▶ Connections through the use of face shims and pin bushings with form and force fit
- ▶ Stable, extensive connection system and coordinated accessories
- ▶ Always available stock

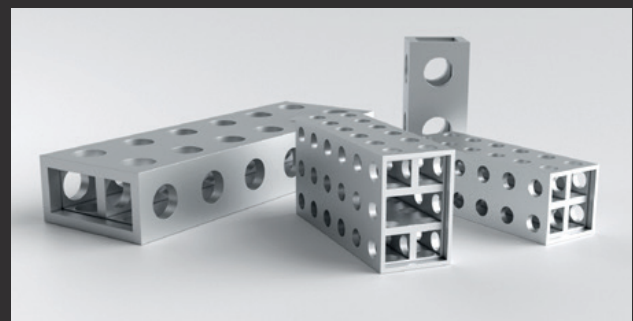

PRECISION TECHNOLOGY

MODULAR AND FLEXIBLE

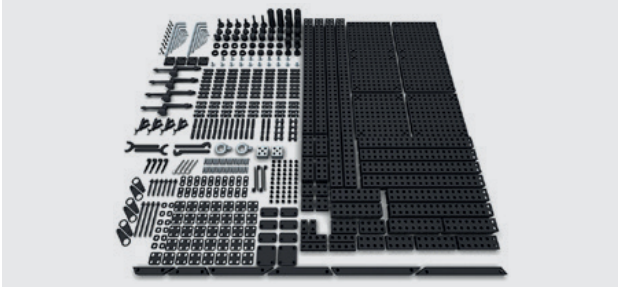

MODULAR SYSTEM FOR MEASUREMENT RECORDING

Is ideal in the application for flexible setups for measurement recordings. These find their application, e.g., in small series, in the training and/or in laboratories.

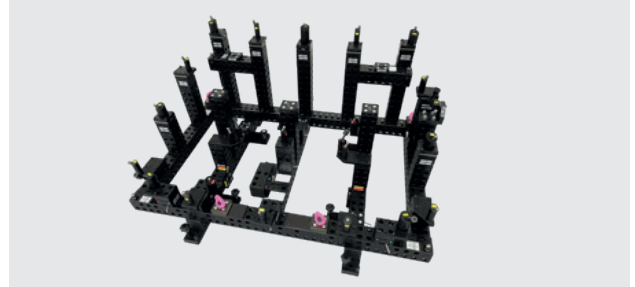

COMPONENT RECORDINGS / MEASUREMENT RECORDINGS

The Paletti precision system is designed for modular, flexible setup of measuring fixtures. This concept allows the fixtures to be created in a cost-efficient, reproducible manner, and retooling is also possible

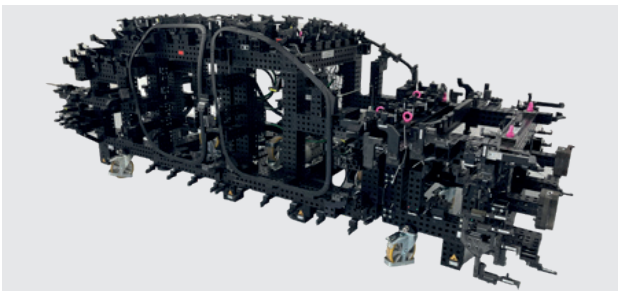

MASTER BUCK

When the highest accuracy is required, Paletti's master blocks are the first choice. Individually adaptable. Components from a wide variety of areas can be fixed and joined in this way.



JOIN MASTER BUCK

Individual parts from sub-welding groups are picked up at the join master buck and joined to form complete assemblies. These are used to analyze stress-free joining and to set up the production equipment.



PERFORATED GRID, SANDWICH PANELS, BASE FRAME, SWING FRAME SYSTEMS

Our perforated grid plates or base frame systems are the ideal basis for the flexible construction of measuring fixtures and devices. They are made of aluminium and are available in natural or black anodized.

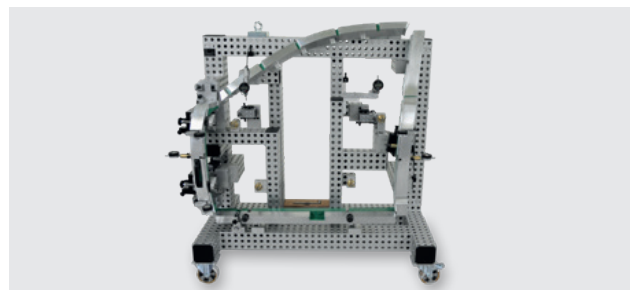

GAUGES, CUBES AND ANALYSIS DEVICES

Our standard components form the basis for gauges and analysis devices. These can also be reused several times, so that highly flexible but also cost-effective fixtures can be created by exchanging the test flanges.

EVERYWHERE IN USE

PALETTI WORLDWIDE

Always nearby - when it comes to working with aluminium profiles and designing system solutions, Paletti is a competent partner with subsidiaries, system partners and representatives worldwide.



HEADQUARTERS MINDEN

Paletti Profilsysteme GmbH & Co. KG
Gewerbepark Meißen 17
32423 Minden
Phone +49 571 38 73 03-0
Fax +49 571 3 69 97
sales@paletti-group.com
www.paletti-group.com



PETERSHAGEN FACTORY

Paletti Profilsysteme GmbH & Co. KG
Dingbreite 15
32469 Petershagen
Phone +49 571 38 73 03-0
Fax +49 571 3 69 97
sales@paletti-group.com
www.paletti-group.com



PALETTI, USA

Paletti USA LLC
145 Keystone Drive
USA-Montgomeryville, PA 18936
Phone +1 267 2 89 00 20
Fax +49 571 3 69 97
sales@palettiusa.com
www.paletti-group.com



PALETTI, GB

Paletti UK LTD
4 Britannia Way
The Valley, Lancashire BL2 2HH
Phone +44 1204 522 123
Fax +44 1204 522 101
sales@palettiuk.com
www.paletti-group.com

SYSTEM PARTNER



Combiflex Produktie & Montage B.V.
Merwedeweg 7
3621 LP Breukelen, Niederlande
Phone +31 346 264 174
Fax +31 346 264 774
info@trapo.nl
www.trapo.nl



BSC Anlagenbau GmbH
Am Industriepark 19
A-9431 St. Stefan, Österreich
Phone +43 4352 81 340
Fax +43 4352 81 340 89
office@bsc-anlagenbau.at
www.bsc-anlagenbau.at



Promatec Automation AG
Gewerbestraße 9
CH-4552 Derendingen, Schweiz
Phone +41 326 82 00 82
Fax +41 326 82 00 89
info@promatec.ch
www.promatec.ch



LIHENG Tech (shanghai) Co., Ltd
Qualified Checking & Measuring
Solution Partner
3911 JIASONG BEI Rd. JIADING District
201805 Shanghai
Volksrepublik China

WE WORK HAND IN HAND

REPRESENTATIONS



ERO-Führungen GmbH

Weißkreuzstraße 16
79843 Unadingen
Germany
Phone +49 7707 158 0
vertrieb@ero-fuehrungen.de
www.ero-fuehrungen.de



IPS-Tec

Poststraße 1
08459 Neukirchen, Germany
Phone +49 3762 7 59 31 00
Fax +49 3762 7 59 31 19
info@ips-tec.de
www.ips-tec.de



Rollco A/S

Skomagervej 13 E
7100 Vejle
Denmark
Phone +45 75 52 26 66
info@rollco.dk
www.rollco.dk



Rollco AB

Box 22234
25024 Helsingborg
Sweden
Phone +46 42 15 00 40
info@rollco.se
www.rollco.se



Rollco OY

Sarankulmankatu 12
33900 Tampere
Finland
Phone +358 207 57 97 90
info@rollco.fi
www.rollco.fi



Rollco Norge AS

Industrigata 6
3414 Lierstranda
Norway
Phone +47 32 84 00 34
info@rollco.no
www.rollco.no



AS-Mechanics bvba

Groenstraat 5930
BE-3800 Sint-Truiden
Belgium
Phone +32 11 78 48 74
info@as-mechanics.be
www.as-mechanics.be



Multiengineering ET

bul. Tsarigradsko sh. 72
BG-1113 Sofia, Bulgarian
Phone +359 28 75 21 09
Fax +359 28 75 21 09
multiengineering@gmail.com
www.multiengineering-bg.com



MMT s.r.o.

Revoluční 40, CZ-46601 Jablonec nad Nisou
Czech Republic
Phone +420 483 35 69 11
Fax +420 483 35 69 10
mmt@mmt.cz
www.mmt.cz



Baccara Automation Control

IL-18915 Kvutzat Geva, Israel
Phone +9 72 46 53 59 60
Fax +9 72 46 53 14 45
sales@baccara.co.il
www.baccara.co.il



Mecano Sistemi S.r.l

Via Consorziiale Saronnino, 70/16
I-21040 ORIGGIO (VA), Italy
Phone +39 029 67 09 05 0
Fax +39 029 67 09 39 6
mecanosistemi@tin.it
www.mecanosistemi.it



IAS Sp. z o.o.

ul. Mydlana 7,
PL-51-502 Wrocław, Poland
Phone +48 071 707 24 00
Fax +48 697 908 484
office@ia-solution.com
www.ia-solution.com



Klare Technologies (Pty) Ltd

226 Market Street Fairland
Johannesburg Gauteng, 2030, South Africa
Phone +27 11 794 9684
Mobile +27 71 473 0180
sales@klaretech.com
www.klaretech.com



Danubelt s.r.o.

Seberiniho 1
SK-821 03 Bratislava
Slovakia
www.danubelt.sk



FACORT

Rua de Entrecampinhos,118
4435-687 Baguim do Monte
Portugal
Phone 00351 229 774 600
www.facort.com

PALETTI

EVERYTHING HAS ITS PLACE

ENGINEERED SYSTEM SOLUTIONS



PROFILE TECHNOLOGY



PROTECTION AND SEPARATION SYSTEMS



ASSEMBLY AND WORKSTATION SYSTEMS



CONVEYOR TECHNOLOGY



LINEAR TECHNOLOGY



TESTING TECHNOLOGY



LASER SAFETY ENCLOSURES



PRECISION ENGINEERING

Paletti Profilsysteme GmbH & Co. KG

Gewerbepark Meißen 17
D-32423 Minden
Phone +49 (571) 38 73 03-0
Fax +49 (571) 3 69 97
sales@paletti-group.com
www.paletti-group.com