

CUTTING TO SIZE:

STEP 1 Mask, measure and mark for cutting. **IMPORTANT:** Check measurements.

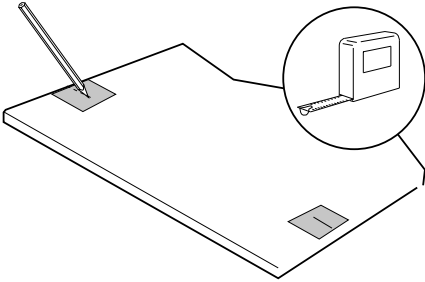

STEP 2 Cut with track or circular saw. We recommend a 3 pass cut.

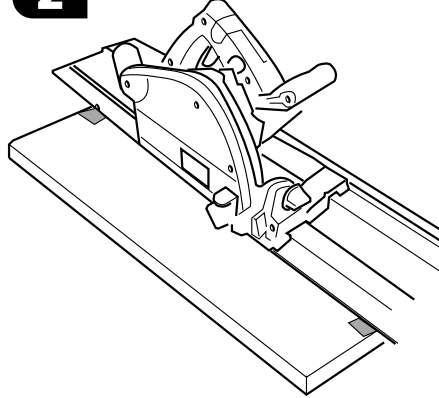

STEP 3 Finish edge with router, 2-3mm final skim pass.

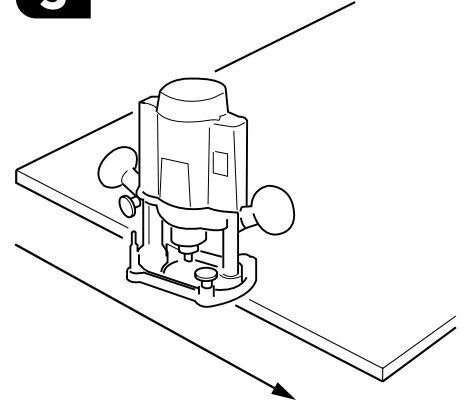

JOINING:

STEP 1 Secure a standard worktop jig to the worktop and router the dog bones using a 6mm cutter to a depth of 8mm. A standard 30mm guide bush can be used.

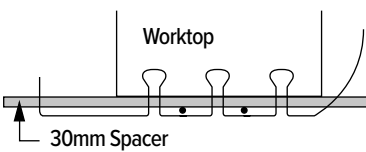
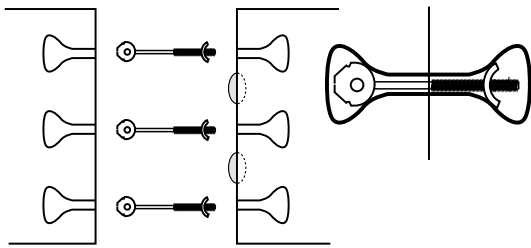

It is important to note that unless a ZipBolt compatible worktop jig is being used, you must pack the front edge of the worktop out using a 30mm spacer.

STEP 2 Cut the biscuit slots. We recommend three ZipBolts and two biscuits per joint.

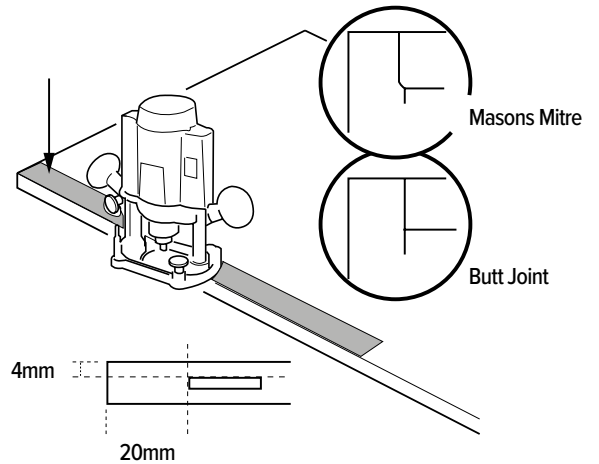

STEP 3 Dry fit the tops to check alignment. Apply the epoxy resin to both the biscuit grooves and along the edge. Fit the biscuits into position and bring the two surfaces together.

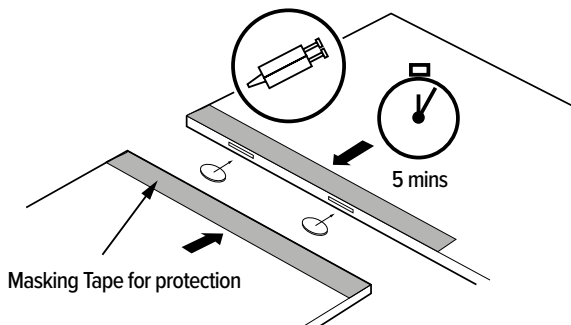

STEP 4 Tighten the ZipBolts checking the top surfaces are flush. Remove any excess glue using the supplied alcohol wipes immediately. The adhesive will cure in around 5 minutes.

