



FRB Series

Three-lobe Roots Blower



FRB Three-lobe Roots Blower

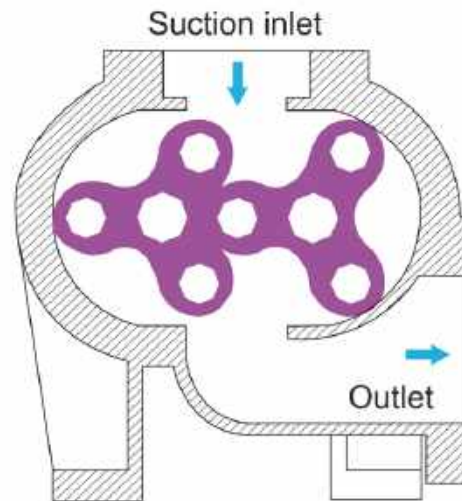

Theory

FRB is a displacement blower, the pressure can be adjusted according to the requirement of the user in allowing range, there are two impellers in the blower body which rotate in the opposite direction, in order to let the impeller rotate, there are some tiny gap between the impeller to body, impeller to impeller. When the impeller rotates through the suction inlet, it can gather an amount of air between the body and impeller, then the impeller go on rotating, and the air will be pressured, the pressure in the body will rise, finally the air has been send to the outlet.

Features

- Wide range of capacity and presure.
Calibre : 32mm-400mm (1.25"-16")
Capacity : 0.38-283m³/min (13-9985CFM)
Pressure : The pressure of one-stage FRB type
up to 8000mmAq (0.8kgf/cm²)
- Delivers completely oil-free air.
- Low oscillation and low noise by dynamic balance which revised by computer.
- Smaller change in capacity against change in pressure.
- High efficiency due to special impeller design, great air-delivery low power.
- Simpler and solider structure, less trouble.
- Highest quality pilot & accurate great applied, long life and low noise assured.
- Standardized product with strict quality control.
- Our rotor has used the most advanced technic, one time for all working process of the siz-shaft method, to enhance the precision.



Externality Construction

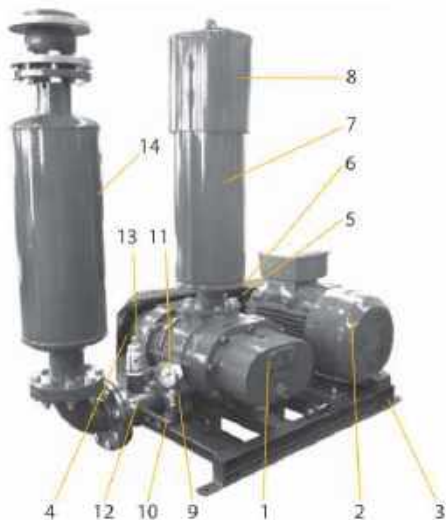

No.	Name
1	Blower body
2	Motor
3	Foundation
4	Pulley
5	Driving belt
6	Belt cover
7	Suction silencer
8	Rain cover
9	Check valve
10	Gauge Pipe
11	Outlet pressure gauge
12	T-joint
13	Relief valve
14	Outlet silencer

Note: FRB-32/FRB-40 Without Outlet Silencer

Type Description

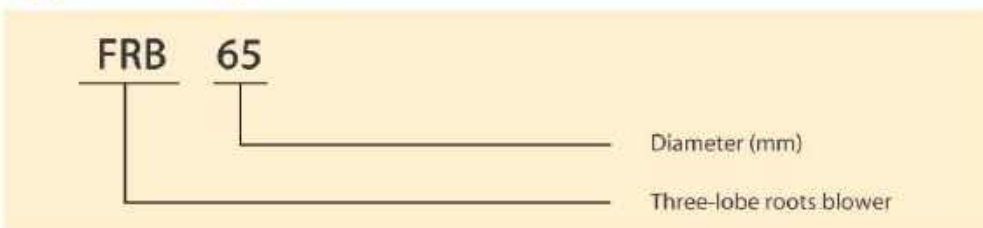

No.	Name	Material	
		GB	JIS
1	Casing	HT250	FC250
2	Bearing housing	HT250	FC250
3	Oil box	HT250	FC250
4	Oil splash	Q235	SS400
5	Bearing washer	Q235	SS400
6	Framework oil seal	NBR	NBR
7	Pulley	HT250	FC250
8	Drive rotor	HT250	FC250
9	Driven rotor	HT250	FC250
10	V-ring	VITON	VITON
11	Bearing	GCr15	SUJ2
12	Gear	20CrMnTi	20CrMnTi
13	Lock washer	Q235	SS400
14	Lock nut	45	S45C
15	Gear box	HT250	FC250
16	Lubrication plug	45	S45C
17	Oil gauge	Assembly	Assembly
18	Purge plug	45	S45C

Note: Different model has a little difference.

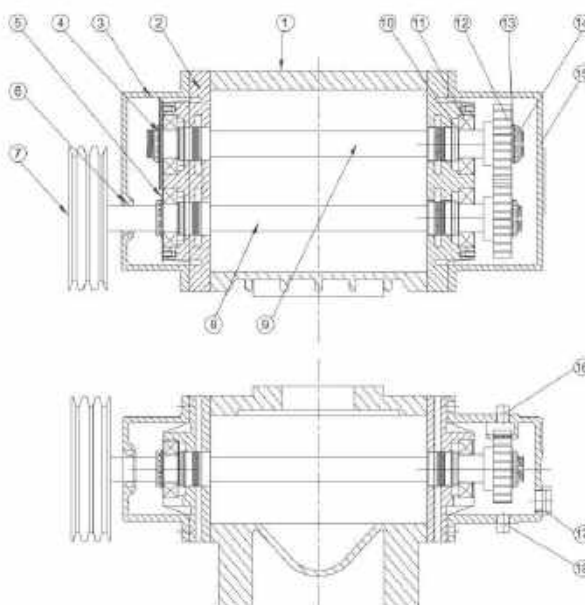

Conversion Table

PRESSURE	atm	kPa	bar	lbt/in ² (psi)	kgf/cm ²	inHg	ftAq	mmHg(Torr)	mmAq
1 atm	1	101.325	1.01325	14.696	1.0333	29.921	33.914	760	10333
1 kPa	0.0099	1	0.01	0.145	0.0102	0.295	0.335	7.5	102
1 bar	0.9869	100	1	14.504	1.0198	29.53	33.47	750	10198
1 lbt/in ² (psi)	0.068	6.894	0.0689	1	0.0703	2.036	2.308	51.71	703
1 kgf/cm ²	0.968	98.062	0.981	14.228	1	28.96	32.82	735.53	10000
1 inHg	0.0334	3.3863	0.0339	0.491	0.0345	1	1.133	25.4	345.3
1 ftAq	0.0295	2.99	0.0299	0.434	0.0305	0.882	1	22.42	304.8
1 mmHg(Torr)	0.013	0.1338	0.00138	0.019	0.0014	0.04	0.045	1	13.6
1 mmAq	0.000097	0.0098	0.000098	0.0014	0.0001	0.003	0.0033	0.074	1

CAPACITY	m ³ /min	l/min	cm ³ /s	in ³ /s	ft ³ /min(cfm)
1 m ³ /min	1	1000	1666.7	1016	35.288
1 l/min	0.001	1	16.67	1.02	0.0353
1 cm ³ /s	0.00006	0.06	1	0.061	0.002
1 in ³ /s	0.00098	0.983	16.39	1	0.035
1 ft ³ /min(cfm)	0.028	28.32	471.95	28.8	1

Pressure Conversion Formula

$$1 \text{ kPa} = 1000 \text{ Pa} = 1000 \text{ N/m}^2$$

$$1 \text{ mbar} = 10.198 \text{ mmAq}$$

$$1 \text{ mmHg(Torr)} = 133.8 \text{ Pa}$$

Working Directions Of Performance Table

1. The performance parameter indicate the type, caliber, revolutions, discharge pressure, actual inlet air capacity and shaft power of the blower.
2. The performance parameter indicate the air quantity in standard suction condition (20°C temperature, absolute pressure 1.0332 kgf/cm² and relative humidity 65%).
3. The reference air capacity (0°C temperature and absolute pressure 1.0332 kgf/cm²) is generally indicated in Nm³/min.
4. The inlet air capacity can be converted as following.

$$Q_2 = Q_1 \times \frac{P_1}{P_2} \times \frac{273 + T_2}{273 + T_1}$$

Q₁ : Air capacity (m³/min) based on absolute pressure P₁ (mmAq) and temperature T₁(°C)

Q₂ : Air capacity (m³/min) based on absolute pressure P₂ (mmAq) and temperature T₂(°C)

5. The motor power is 1.1~1.3 multiple of shaft power.
6. The error of the parameter is about 5%.



Performance Parameters

Qs(m³/min) Pressure(mmAq) La(kW)

Type	RPM	1000mmAq		2000mmAq		3000mmAq		4000mmAq		5000mmAq		6000mmAq		7000mmAq		8000mmAq	
		Qs	La	Qs	La	Qs	La	Qs	La	Qs	La	Qs	La	Qs	La	Qs	La
FRB-32	1500	0.56	0.17	0.51	0.28	0.47	0.40	0.43	0.51	0.40	0.62	0.38	0.73	-	-	-	-
	1750	0.68	0.20	0.62	0.33	0.58	0.46	0.55	0.59	0.52	0.72	0.49	0.86	-	-	-	-
	2000	0.79	0.23	0.74	0.38	0.70	0.53	0.66	0.68	0.63	0.83	0.61	0.98	-	-	-	-
	2300	0.93	0.26	0.88	0.43	0.84	0.61	0.80	0.78	0.77	0.95	0.74	1.13	-	-	-	-
	2600	1.07	0.29	1.02	0.49	0.97	0.68	0.94	0.88	0.91	1.08	0.88	1.27	-	-	-	-
	3000	1.25	0.34	1.20	0.56	1.16	0.79	1.12	1.02	1.09	1.24	1.07	1.47	-	-	-	-
FRB-40	850	1.02	0.42	0.89	0.64	0.79	0.85	0.71	1.07	0.63	1.29	-	-	-	-	-	-
	950	1.18	0.47	1.05	0.71	0.95	0.95	0.86	1.20	0.79	1.44	-	-	-	-	-	-
	1050	1.33	0.52	1.20	0.79	1.10	1.06	1.02	1.32	0.94	1.59	-	-	-	-	-	-
	1150	1.49	0.57	1.36	0.86	1.26	1.16	1.18	1.45	1.10	1.74	-	-	-	-	-	-
	1250	1.65	0.62	1.52	0.94	1.42	1.26	1.33	1.58	1.26	1.90	1.19	2.22	1.13	2.54	1.07	2.86
	1350	1.80	0.67	1.67	1.01	1.57	1.36	1.49	1.70	1.42	2.05	1.35	2.39	1.29	2.74	1.23	3.08
	1450	1.96	0.71	1.83	1.09	1.73	1.46	1.65	1.83	1.57	2.20	1.50	2.57	1.44	2.94	1.39	3.31
	1550	2.12	0.76	1.99	1.16	1.89	1.56	1.80	1.95	1.73	2.35	1.66	2.75	1.60	3.15	1.54	3.54
	1650	2.27	0.81	2.14	1.24	2.04	1.66	1.96	2.08	1.89	2.50	1.82	2.93	1.76	3.35	1.70	3.77
	1750	2.43	0.86	2.30	1.31	2.20	1.76	2.12	2.21	2.04	2.65	1.98	3.10	1.91	3.55	1.86	4.00
1850	2.59	0.91	2.46	1.39	2.36	1.86	2.27	2.33	2.20	2.81	2.13	3.28	2.07	3.75	2.01	4.23	
1950	2.74	0.96	2.61	1.46	2.51	1.96	2.43	2.46	2.36	2.96	2.29	3.46	2.23	3.96	2.17	4.46	
FRB-50	850	1.81	0.61	1.64	0.97	1.52	1.34	1.41	1.70	1.31	2.06	1.22	2.42	1.14	2.79	1.07	3.15
	950	2.07	0.68	1.91	1.09	1.78	1.49	1.67	1.90	1.57	2.30	1.48	2.71	1.40	3.11	1.33	3.52
	1050	2.34	0.75	2.17	1.20	2.04	1.65	1.93	2.10	1.83	2.55	1.75	2.99	1.67	3.44	1.59	3.89
	1150	2.60	0.82	2.43	1.32	2.30	1.81	2.19	2.30	2.09	2.79	2.01	3.28	1.93	3.77	1.85	4.26
	1250	2.86	0.90	2.69	1.43	2.56	1.96	2.45	2.50	2.35	3.03	2.27	3.56	2.19	4.10	2.11	4.63
	1350	3.12	0.97	2.95	1.54	2.82	2.12	2.71	2.70	2.62	3.27	2.53	3.85	2.45	4.42	2.37	5.00
	1450	3.38	1.04	3.21	1.66	3.08	2.28	2.97	2.90	2.88	3.51	2.79	4.13	2.71	4.75	2.64	5.37
	1550	3.64	1.11	3.47	1.77	3.34	2.43	3.23	3.10	3.14	3.76	3.05	4.42	2.97	5.08	2.90	5.74
	1650	3.90	1.18	3.73	1.89	3.61	2.59	3.50	3.30	3.40	4.00	3.31	4.70	3.23	5.41	3.16	6.11
	1750	4.16	1.26	4.00	2.00	3.87	2.75	3.76	3.50	3.66	4.24	3.57	4.99	3.49	5.74	3.42	6.48
1850	4.43	1.33	4.26	2.12	4.13	2.91	4.02	3.70	3.92	4.48	3.84	5.27	3.76	6.06	3.68	6.85	
1950	4.69	1.40	4.52	2.23	4.39	3.06	4.28	3.89	4.18	4.73	4.10	5.56	4.02	6.39	3.94	7.22	
FRB-65	850	2.38	0.79	2.16	1.18	2.00	1.66	1.86	2.13	1.74	2.60	1.63	3.07	1.53	3.54	1.44	4.01
	950	2.71	0.88	2.50	1.32	2.34	1.85	2.20	2.38	2.08	2.91	1.97	3.43	1.87	3.96	1.78	4.49
	1050	3.05	0.97	2.84	1.46	2.68	2.05	2.54	2.63	2.42	3.21	2.31	3.79	2.21	4.38	2.12	4.96
	1150	3.39	1.06	3.18	1.60	3.02	2.24	2.88	2.88	2.76	3.52	2.65	4.15	2.55	4.79	2.46	5.43
	1250	3.73	1.16	3.52	1.74	3.36	2.44	3.22	3.13	3.10	3.82	2.99	4.52	2.89	5.21	2.80	5.90
	1350	4.07	1.25	3.86	1.88	3.70	2.63	3.56	3.38	3.44	4.13	3.33	4.88	3.23	5.63	3.14	6.38
	1450	4.41	1.34	4.20	2.02	4.04	2.83	3.90	3.63	3.78	4.43	3.67	5.24	3.57	6.04	3.48	6.85
	1550	4.75	1.43	4.54	2.16	4.38	3.02	4.24	3.88	4.12	4.74	4.01	5.60	3.91	6.46	3.82	7.32
	1650	5.09	1.53	4.88	2.30	4.72	3.22	4.58	4.13	4.46	5.05	4.35	5.96	4.25	6.88	4.16	7.79
	1750	5.43	1.62	5.22	2.44	5.06	3.41	4.92	4.38	4.80	5.35	4.69	6.32	4.59	7.29	4.50	8.26
1850	5.77	1.71	5.56	2.58	5.40	3.61	5.26	4.63	5.14	5.66	5.03	6.68	4.93	7.71	4.84	8.74	
1950	6.11	1.80	5.90	2.72	5.74	3.80	5.60	4.88	5.48	5.96	5.37	7.05	5.27	8.13	5.18	9.21	
FRB-80	800	4.11	1.30	3.83	2.09	3.62	2.87	3.44	3.65	3.28	4.44	3.13	5.22	3.00	6.00	2.87	6.78
	900	4.71	1.47	4.43	2.35	4.22	3.23	4.03	4.11	3.87	4.99	3.73	5.87	3.60	6.75	3.47	7.63
	1000	5.31	1.63	5.03	2.61	4.82	3.59	4.63	4.57	4.47	5.55	4.33	6.52	4.20	7.50	4.07	8.48
	1100	5.91	1.79	5.63	2.87	5.42	3.95	5.23	5.02	5.07	6.10	4.93	7.18	4.79	8.25	4.67	9.33



Performance Parameters

Qs(m³/min) Pressure(mmAq) La(kW)

Type	RPM	1000mmAq		2000mmAq		3000mmAq		4000mmAq		5000mmAq		6000mmAq		7000mmAq		8000mmAq	
		Qs	La	Qs	La	Qs	La	Qs	La	Qs	La	Qs	La	Qs	La	Qs	La
FRB-80	1200	6.51	1.96	6.23	3.13	6.01	4.31	5.83	5.48	5.67	6.65	5.53	7.83	5.39	9.00	5.27	10.18
	1300	7.11	2.12	6.83	3.39	6.61	4.66	6.43	5.94	6.27	7.21	6.13	8.48	5.99	9.75	5.87	11.03
	1400	7.71	2.28	7.43	3.65	7.21	5.02	7.03	6.39	6.87	7.76	6.73	9.13	6.59	10.50	6.47	11.87
	1500	8.31	2.45	8.03	3.91	7.81	5.38	7.63	6.85	7.47	8.32	7.32	9.79	7.19	11.25	7.07	12.72
	1600	8.91	2.61	8.63	4.18	8.41	5.74	8.23	7.31	8.07	8.87	7.92	10.44	7.79	12.00	7.67	13.57
	1650	9.21	2.69	8.93	4.31	8.71	5.92	8.53	7.54	8.37	9.15	8.22	10.76	8.09	12.38	7.97	13.99
	1750	9.81	2.85	9.53	4.57	9.31	6.28	9.13	7.99	8.97	9.70	8.82	11.42	8.69	13.13	8.57	14.84
	1850	10.41	3.02	10.12	4.83	9.91	6.64	9.73	8.45	9.57	10.26	9.42	12.07	9.29	13.88	9.16	15.69
	1950	11.00	3.18	10.72	5.09	10.51	7.00	10.33	8.91	10.17	10.81	10.02	12.72	9.89	14.63	9.76	16.54
	FRB-100	800	5.78	1.98	5.39	3.07	5.09	4.17	4.84	5.26	4.62	6.36	4.42	7.46	4.24	8.55	4.07
900		6.61	2.22	6.23	3.46	5.93	4.69	5.68	5.92	5.46	7.15	5.26	8.39	5.08	9.62	4.91	10.85
1000		7.45	2.47	7.07	3.84	6.77	5.21	6.52	6.58	6.30	7.95	6.10	9.32	5.91	10.69	5.74	12.06
1100		8.29	2.72	7.90	4.22	7.61	5.73	7.36	7.24	7.14	8.74	6.94	10.25	6.75	11.76	6.58	13.27
1200		9.13	2.96	8.74	4.61	8.45	6.25	8.20	7.90	7.98	9.54	7.78	11.18	7.59	12.83	7.42	14.47
1300		9.97	3.21	9.58	4.99	9.29	6.77	9.03	8.55	8.81	10.33	8.61	12.12	8.43	13.90	8.26	15.68
1400		10.81	3.46	10.42	5.37	10.12	7.29	9.87	9.21	9.65	11.13	9.45	13.05	9.27	14.97	9.10	16.88
1500		11.65	3.70	11.26	5.76	10.96	7.81	10.71	9.87	10.49	11.92	10.29	13.98	10.11	16.03	9.94	18.09
1600		12.49	3.95	12.10	6.14	11.80	8.33	11.55	10.53	11.33	12.72	11.13	14.91	10.95	17.10	10.78	19.30
1650		12.91	4.07	12.52	6.33	12.22	8.60	11.97	10.86	11.75	13.12	11.55	15.38	11.37	17.64	11.20	19.90
FRB-125A	780	8.59	2.61	8.17	4.18	7.85	5.74	7.58	7.31	7.34	8.88	7.13	10.44	6.93	12.01	6.75	13.58
	830	9.20	2.78	8.78	4.44	8.46	6.11	8.20	7.78	7.96	9.45	7.74	11.11	7.55	12.78	7.36	14.45
	880	9.82	2.95	9.40	4.71	9.08	6.48	8.81	8.25	8.57	10.01	8.36	11.78	8.16	13.55	7.98	15.32
	930	10.43	3.11	10.01	4.98	9.69	6.85	9.42	8.72	9.19	10.58	8.97	12.45	8.78	14.32	8.59	16.19
	990	11.17	3.31	10.75	5.30	10.43	7.29	10.16	9.28	9.93	11.27	9.71	13.25	9.51	15.24	9.33	17.23
	1050	11.91	3.51	11.49	5.62	11.17	7.73	10.90	9.84	10.66	11.95	10.45	14.06	10.25	16.17	10.07	18.28
	1110	12.64	3.72	12.23	5.94	11.91	8.17	11.64	10.40	11.40	12.63	11.19	14.86	10.99	17.09	10.81	19.32
	1180	13.50	3.95	13.09	6.32	12.77	8.69	12.50	11.06	12.26	13.43	12.05	15.80	11.85	18.17	11.67	20.54
	1250	14.36	4.18	13.95	6.69	13.63	9.20	13.36	11.71	13.12	14.23	12.91	16.74	12.71	19.25	12.53	21.76
	1320	15.23	4.42	14.81	7.07	14.49	9.72	14.22	12.37	13.98	15.02	13.77	17.67	13.57	20.32	13.39	22.97
FRB-125	780	12.64	3.82	12.08	6.11	11.64	8.39	11.27	10.68	10.95	12.97	10.66	15.26	10.39	17.55	10.14	19.84
	830	13.54	4.06	12.97	6.50	12.54	8.93	12.17	11.37	11.85	13.81	11.55	16.24	11.28	18.68	11.03	21.11
	880	14.44	4.30	13.87	6.89	13.44	9.47	13.07	12.05	12.75	14.64	12.45	17.22	12.18	19.80	11.93	22.39
	930	15.34	4.55	14.77	7.28	14.34	10.01	13.97	12.74	13.64	15.47	13.35	18.20	13.08	20.93	12.83	23.66
	990	16.42	4.84	15.85	7.75	15.41	10.65	15.05	13.56	14.72	16.47	14.43	19.37	14.16	22.28	13.91	25.18
	1050	17.50	5.14	16.93	8.22	16.49	11.30	16.12	14.38	15.80	17.46	15.51	20.55	15.24	23.63	14.99	26.71
	1110	18.57	5.43	18.01	8.69	17.57	11.95	17.20	15.20	16.88	18.46	16.59	21.72	16.32	24.98	16.07	28.24
	1180	19.83	5.77	19.26	9.24	18.83	12.70	18.46	16.16	18.14	19.63	17.84	23.09	17.57	26.55	17.32	30.02



Performance Parameters

Qs(m³/min) Pressure(mmAq) La(kW)

Type	RPM	1000mmAq		2000mmAq		3000mmAq		4000mmAq		5000mmAq		6000mmAq		7000mmAq		8000mmAq	
		Qs	La	Qs	La	Qs	La	Qs	La	Qs	La	Qs	La	Qs	La	Qs	La
		FRB-125	1250	21.09	6.11	20.52	9.78	20.09	13.45	19.72	17.12	19.39	20.79	19.10	24.46	18.83	28.13
	1320	22.35	6.46	21.78	10.33	21.34	14.21	20.98	18.08	20.65	21.96	20.36	25.83	20.09	29.70	19.84	33.58
	1390	23.61	6.80	23.04	10.88	22.60	14.96	22.23	19.04	21.91	23.12	21.62	27.20	21.35	31.28	21.10	35.36
	1470	25.04	7.19	24.48	11.51	24.04	15.82	23.67	20.14	23.35	24.45	23.06	28.76	22.79	33.08	22.53	37.39
	1560	26.66	7.63	26.09	12.21	25.66	16.79	25.29	21.37	24.97	25.95	24.67	30.53	24.40	35.10	24.15	39.68
	1650	28.28	8.07	27.71	12.91	27.27	17.76	26.91	22.60	26.58	27.44	26.29	32.29	26.02	37.13	25.77	41.97
	1750	30.08	8.56	29.51	13.70	29.07	18.83	28.70	23.97	28.38	29.11	28.09	34.24	27.82	39.38	27.57	44.52
	1850	31.87	9.05	31.30	14.48	30.87	19.91	30.50	25.34	30.18	30.77	29.88	36.20	29.61	41.63	29.36	47.06
FRB-150	780	16.35	4.92	15.64	7.87	15.09	10.82	14.62	13.78	14.22	16.73	13.85	19.68	13.51	22.63	13.20	25.59
	830	17.51	5.24	16.79	8.38	16.25	11.52	15.78	14.66	15.38	17.80	15.01	20.94	14.67	24.08	14.35	27.23
	880	18.67	5.55	17.95	8.88	17.40	12.21	16.94	15.54	16.53	18.87	16.17	22.20	15.83	25.53	15.51	28.87
	930	19.83	5.87	19.11	9.39	18.56	12.91	18.10	16.43	17.69	19.95	17.33	23.47	16.99	26.99	16.67	30.51
	990	21.22	6.24	20.50	9.99	19.95	13.74	19.49	17.49	19.08	21.23	18.72	24.98	18.38	28.73	18.06	32.47
	1050	22.61	6.62	21.89	10.60	21.34	14.57	20.88	18.55	20.47	22.52	20.11	26.49	19.77	30.47	19.45	34.44
	1110	24.00	7.00	23.28	11.20	22.73	15.40	22.27	19.61	21.86	23.81	21.50	28.01	21.16	32.21	20.84	36.41
	1180	25.62	7.44	24.90	11.91	24.36	16.38	23.89	20.84	23.49	25.31	23.12	29.77	22.78	34.24	22.46	38.71
	1250	27.24	7.89	26.53	12.62	25.98	17.35	25.52	22.08	25.11	26.81	24.74	31.54	24.40	36.27	24.09	41.00
	1320	28.86	8.33	28.15	13.32	27.60	18.32	27.14	23.31	26.73	28.31	26.36	33.31	26.02	38.30	25.71	43.30
	1390	30.48	8.77	29.77	14.03	29.22	19.29	28.76	24.55	28.35	29.81	27.98	35.07	27.65	40.33	27.33	45.59
	1470	32.34	9.27	31.62	14.84	31.08	20.40	30.61	25.96	30.21	31.53	29.84	37.09	29.50	42.65	29.18	48.22
	1560	34.42	9.84	33.71	15.74	33.16	21.65	32.70	27.55	32.29	33.46	31.92	39.36	31.59	45.27	31.27	51.17
	1650	36.51	10.41	35.80	16.65	35.25	22.90	34.78	29.14	34.38	35.39	34.01	41.63	33.67	47.88	33.36	54.12
	1750	38.83	11.04	38.11	17.66	37.56	24.29	37.10	30.91	36.69	37.53	36.33	44.16	35.99	50.78	35.67	57.40
	1850	41.14	11.67	40.43	18.67	39.88	25.67	39.42	32.68	39.01	39.68	38.64	46.68	38.31	53.68	37.99	60.68
FRB-200A	830	28.66	8.40	27.75	13.44	27.06	18.48	26.47	23.51	25.96	28.55	25.49	33.59	25.06	38.63	24.66	43.67
	880	30.52	8.90	29.61	14.25	28.92	19.59	28.33	24.93	27.81	30.27	27.35	35.62	26.92	40.96	26.52	46.30
	930	32.38	9.41	31.47	15.06	30.78	20.70	30.19	26.35	29.67	31.99	29.21	37.84	28.78	43.29	28.38	48.93
	990	34.61	10.02	33.70	16.03	33.01	22.04	32.42	28.05	31.90	34.06	31.44	40.07	31.01	46.08	30.61	52.09
	1050	36.84	10.62	35.93	17.00	35.24	23.37	34.65	29.75	34.13	36.12	33.67	42.50	33.24	48.87	32.84	55.25
	1110	39.07	11.23	38.16	17.97	37.47	24.71	36.88	31.45	36.36	38.19	35.90	44.92	35.47	51.66	35.07	58.40
	1180	41.67	11.94	40.76	19.10	40.07	26.27	39.48	33.43	38.96	40.59	38.50	47.76	38.07	54.92	37.67	62.08
	1250	44.27	12.65	43.37	20.24	42.67	27.82	42.08	35.41	41.57	43.00	41.10	50.59	40.67	58.18	40.27	65.77
	1320	46.87	13.36	45.97	21.37	45.27	29.38	44.69	37.40	44.17	45.41	43.70	53.42	43.27	61.44	42.87	69.45
	1390	49.48	14.06	48.57	22.50	47.87	30.94	47.29	39.38	46.77	47.82	46.30	56.26	45.87	64.70	45.47	73.13
	1470	52.45	14.87	51.54	23.80	50.85	32.72	50.26	41.65	49.74	50.57	49.28	59.49	48.85	68.42	48.45	77.34
FRB-200	880	39.61	11.45	38.59	18.32	37.81	25.19	37.16	32.05	36.58	38.92	36.06	45.79	35.58	52.66	35.13	59.53
	930	42.00	12.10	40.98	19.36	40.20	26.62	39.55	33.88	38.97	41.13	38.45	48.39	37.97	55.65	37.52	62.91
	990	44.86	12.88	43.85	20.61	43.07	28.33	42.41	36.06	41.84	43.79	41.31	51.52	40.83	59.24	40.39	66.97
	1050	47.73	13.66	46.72	21.86	45.94	30.05	45.28	38.25	44.70	46.44	44.18	54.64	43.70	62.83	43.25	71.03
	1110	50.60	14.44	49.58	23.10	48.81	31.77	48.15	40.43	47.57	49.10	47.05	57.76	46.57	66.42	46.12	75.09
	1180	53.94	15.35	52.93	24.56	52.15	33.77	51.49	42.98	50.92	52.19	50.39	61.40	49.91	70.61	49.47	79.82
	1250	57.29	16.26	56.27	26.02	55.50	35.77	54.84	45.53	54.26	55.29	53.74	65.05	53.26	74.80	52.81	84.56
	1320	60.63	17.17	59.62	27.48	58.84	37.78	58.18	48.08	57.61	58.38	57.08	68.69	56.60	78.99	56.16	89.29
	1390	63.98	18.08	62.96	28.93	62.19	39.78	61.53	50.63	60.95	61.48	60.43	72.33	59.95	83.18	59.50	94.03
	1470	67.80	19.12	66.79	30.60	66.01	42.07	65.35	53.55	64.78	65.02	64.25	76.49	63.77	87.97	63.33	99.44



Performance Parameters

Qs(m³/min) Pressure(mmAq) La(kW)

Type	RPM	1000mmAq		2000mmAq		3000mmAq		4000mmAq		5000mmAq		6000mmAq		7000mmAq		8000mmAq																																																																																																																																																																																																																																																																																																																																																																																																																																																																																																																																																																																																																																																																																																																																																																																																			
		Qs	La	Qs	La	Qs	La	Qs	La	Qs	La	Qs	La	Qs	La	Qs	La																																																																																																																																																																																																																																																																																																																																																																																																																																																																																																																																																																																																																																																																																																																																																																																																		
		FRB-250 <tr><td rowspan="10">FRB-250</td><td>830</td><td>50.02</td><td>14.40</td><td>48.83</td><td>23.03</td><td>47.92</td><td>31.67</td><td>47.15</td><td>40.31</td><td>46.48</td><td>48.95</td><td>45.87</td><td>57.59</td><td>45.30</td><td>66.22</td><td>44.78</td><td>74.86</td></tr> <tr><td>880</td><td>53.21</td><td>15.26</td><td>52.02</td><td>24.42</td><td>51.11</td><td>33.58</td><td>50.34</td><td>42.74</td><td>49.66</td><td>51.90</td><td>49.05</td><td>61.06</td><td>48.49</td><td>70.21</td><td>47.97</td><td>79.37</td></tr> <tr><td>930</td><td>56.39</td><td>16.13</td><td>55.20</td><td>25.81</td><td>54.29</td><td>35.49</td><td>53.53</td><td>45.17</td><td>52.85</td><td>54.85</td><td>52.24</td><td>64.52</td><td>51.68</td><td>74.20</td><td>51.15</td><td>83.88</td></tr> <tr><td>990</td><td>60.21</td><td>17.17</td><td>59.03</td><td>27.48</td><td>58.12</td><td>37.78</td><td>57.35</td><td>48.08</td><td>56.67</td><td>58.38</td><td>56.06</td><td>68.69</td><td>55.50</td><td>78.99</td><td>54.97</td><td>89.29</td></tr> <tr><td>1050</td><td>64.04</td><td>18.21</td><td>62.85</td><td>29.14</td><td>61.94</td><td>40.07</td><td>61.17</td><td>51.00</td><td>60.50</td><td>61.92</td><td>59.88</td><td>72.85</td><td>59.32</td><td>83.78</td><td>58.80</td><td>94.71</td></tr> <tr><td>1110</td><td>67.86</td><td>19.25</td><td>66.67</td><td>30.81</td><td>65.76</td><td>42.36</td><td>64.99</td><td>53.91</td><td>64.32</td><td>65.46</td><td>63.71</td><td>77.01</td><td>63.14</td><td>88.57</td><td>62.62</td><td>100.12</td></tr> <tr><td>1180</td><td>72.32</td><td>20.47</td><td>71.13</td><td>32.75</td><td>70.22</td><td>45.03</td><td>69.46</td><td>57.31</td><td>68.78</td><td>69.59</td><td>68.17</td><td>81.87</td><td>67.60</td><td>94.15</td><td>67.08</td><td>106.43</td></tr> <tr><td>1250</td><td>76.78</td><td>21.68</td><td>75.59</td><td>34.69</td><td>74.68</td><td>47.70</td><td>73.92</td><td>60.71</td><td>73.24</td><td>73.72</td><td>72.63</td><td>86.73</td><td>72.06</td><td>99.74</td><td>71.54</td><td>112.75</td></tr> <tr><td>1320</td><td>81.24</td><td>22.90</td><td>80.05</td><td>36.63</td><td>79.14</td><td>50.37</td><td>78.38</td><td>64.11</td><td>77.70</td><td>77.85</td><td>77.09</td><td>91.58</td><td>76.53</td><td>105.32</td><td>76.00</td><td>119.06</td></tr> <tr><td>1390</td><td>85.70</td><td>24.11</td><td>84.51</td><td>38.58</td><td>83.60</td><td>53.04</td><td>82.84</td><td>67.51</td><td>82.16</td><td>81.97</td><td>81.55</td><td>96.44</td><td>80.99</td><td>110.91</td><td>80.46</td><td>125.37</td></tr> <tr><td>1470</td><td>90.80</td><td>25.50</td><td>89.61</td><td>40.80</td><td>88.70</td><td>56.10</td><td>87.93</td><td>71.39</td><td>87.26</td><td>86.69</td><td>86.65</td><td>101.99</td><td>86.08</td><td>117.29</td><td>85.56</td><td>132.59</td></tr> FRB-300A <tr><td rowspan="10">FRB-300A</td><td>830</td><td>66.52</td><td>19.20</td><td>64.86</td><td>30.71</td><td>63.59</td><td>42.23</td><td>62.52</td><td>53.75</td><td>61.57</td><td>65.26</td><td>60.72</td><td>76.78</td><td>59.94</td><td>88.30</td><td>59.21</td><td>99.82</td></tr> <tr><td>880</td><td>70.76</td><td>20.35</td><td>69.11</td><td>32.56</td><td>67.84</td><td>44.77</td><td>66.77</td><td>56.99</td><td>65.82</td><td>69.20</td><td>64.97</td><td>81.41</td><td>64.18</td><td>93.62</td><td>63.45</td><td>105.83</td></tr> <tr><td>930</td><td>75.01</td><td>21.51</td><td>73.36</td><td>34.41</td><td>72.09</td><td>47.32</td><td>71.01</td><td>60.22</td><td>70.07</td><td>73.13</td><td>69.22</td><td>86.03</td><td>68.43</td><td>98.94</td><td>67.70</td><td>111.84</td></tr> <tr><td>990</td><td>80.11</td><td>22.90</td><td>78.45</td><td>36.63</td><td>77.18</td><td>50.37</td><td>76.11</td><td>64.11</td><td>75.17</td><td>77.85</td><td>74.31</td><td>91.58</td><td>73.53</td><td>105.32</td><td>72.80</td><td>119.06</td></tr> <tr><td>1050</td><td>85.21</td><td>24.28</td><td>83.55</td><td>38.85</td><td>82.28</td><td>53.42</td><td>81.21</td><td>67.99</td><td>80.27</td><td>82.56</td><td>79.41</td><td>97.13</td><td>78.63</td><td>111.70</td><td>77.90</td><td>126.27</td></tr> <tr><td>1110</td><td>90.30</td><td>25.67</td><td>88.65</td><td>41.07</td><td>87.38</td><td>56.48</td><td>86.31</td><td>71.88</td><td>85.36</td><td>87.28</td><td>84.51</td><td>102.68</td><td>83.72</td><td>118.09</td><td>82.99</td><td>133.49</td></tr> <tr><td>1180</td><td>96.25</td><td>27.29</td><td>94.60</td><td>43.66</td><td>93.32</td><td>60.04</td><td>92.25</td><td>76.41</td><td>91.31</td><td>92.79</td><td>90.46</td><td>109.16</td><td>89.67</td><td>125.53</td><td>88.94</td><td>141.91</td></tr> <tr><td>1250</td><td>102.20</td><td>28.91</td><td>100.54</td><td>46.25</td><td>99.27</td><td>63.60</td><td>98.20</td><td>80.95</td><td>97.26</td><td>98.29</td><td>96.40</td><td>115.64</td><td>95.62</td><td>132.98</td><td>94.89</td><td>150.33</td></tr> <tr><td>1320</td><td>108.15</td><td>30.53</td><td>106.49</td><td>48.84</td><td>105.22</td><td>67.16</td><td>104.15</td><td>85.48</td><td>103.20</td><td>103.79</td><td>102.35</td><td>122.11</td><td>101.57</td><td>140.43</td><td>100.84</td><td>158.75</td></tr> <tr><td>1390</td><td>114.09</td><td>32.15</td><td>112.44</td><td>51.43</td><td>111.17</td><td>70.72</td><td>110.09</td><td>90.01</td><td>109.15</td><td>109.30</td><td>108.30</td><td>128.59</td><td>107.51</td><td>147.88</td><td>106.78</td><td>167.16</td></tr> <tr><td>1470</td><td>120.89</td><td>34.00</td><td>119.23</td><td>54.40</td><td>117.96</td><td>74.79</td><td>116.89</td><td>95.19</td><td>115.95</td><td>115.59</td><td>115.09</td><td>135.99</td><td>114.31</td><td>156.39</td><td>113.58</td><td>176.78</td></tr> FRB-300 <tr><td rowspan="10">FRB-300</td><td>800</td><td>101.28</td><td>29.11</td><td>98.93</td><td>46.58</td><td>97.12</td><td>64.05</td><td>95.60</td><td>81.52</td><td>94.26</td><td>98.99</td><td>93.05</td><td>116.46</td><td>91.94</td><td>133.92</td><td>90.90</td><td>151.39</td></tr> <tr><td>900</td><td>114.64</td><td>32.75</td><td>112.30</td><td>52.40</td><td>110.49</td><td>72.06</td><td>108.97</td><td>91.71</td><td>107.63</td><td>111.36</td><td>106.42</td><td>131.01</td><td>105.31</td><td>150.66</td><td>104.27</td><td>170.32</td></tr> <tr><td>1000</td><td>128.01</td><td>36.39</td><td>125.66</td><td>58.23</td><td>123.86</td><td>80.06</td><td>122.34</td><td>101.90</td><td>121.00</td><td>123.73</td><td>119.79</td><td>145.57</td><td>118.68</td><td>167.40</td><td>117.64</td><td>189.24</td></tr> <tr><td>1100</td><td>141.38</td><td>40.05</td><td>139.03</td><td>64.05</td><td>137.23</td><td>88.07</td><td>135.71</td><td>112.09</td><td>134.37</td><td>136.11</td><td>133.16</td><td>160.13</td><td>132.05</td><td>184.14</td><td>131.01</td><td>208.16</td></tr> <tr><td>1200</td><td>154.75</td><td>43.67</td><td>152.40</td><td>69.87</td><td>150.60</td><td>96.08</td><td>149.08</td><td>122.28</td><td>147.74</td><td>148.48</td><td>146.53</td><td>174.68</td><td>145.41</td><td>200.89</td><td>144.38</td><td>227.09</td></tr> <tr><td>1300</td><td>168.12</td><td>47.31</td><td>165.77</td><td>75.70</td><td>163.97</td><td>104.08</td><td>162.45</td><td>132.47</td><td>161.11</td><td>160.85</td><td>159.90</td><td>189.24</td><td>158.78</td><td>217.63</td><td>157.75</td><td>246.01</td></tr> <tr><td>1400</td><td>181.49</td><td>50.95</td><td>179.14</td><td>81.52</td><td>177.34</td><td>112.09</td><td>175.82</td><td>142.66</td><td>174.48</td><td>173.23</td><td>173.27</td><td>203.80</td><td>172.15</td><td>234.37</td><td>171.12</td><td>264.94</td></tr> <tr><td>600</td><td>118.60</td><td>34.31</td><td>115.52</td><td>54.90</td><td>113.16</td><td>75.49</td><td>111.16</td><td>96.08</td><td>109.40</td><td>116.66</td><td>107.82</td><td>137.25</td><td>106.36</td><td>157.84</td><td>105.00</td><td>178.43</td></tr> <tr><td>700</td><td>139.61</td><td>40.03</td><td>136.53</td><td>64.05</td><td>134.16</td><td>88.07</td><td>132.17</td><td>112.09</td><td>130.41</td><td>136.11</td><td>128.82</td><td>160.13</td><td>127.36</td><td>184.14</td><td>126.00</td><td>208.16</td></tr> <tr><td>800</td><td>160.62</td><td>45.75</td><td>157.54</td><td>73.20</td><td>155.17</td><td>100.65</td><td>153.18</td><td>128.10</td><td>151.42</td><td>155.55</td><td>149.83</td><td>183.00</td><td>148.37</td><td>210.45</td><td>147.01</td><td>237.90</td></tr> FRB-350 <tr><td rowspan="10">FRB-350</td><td>900</td><td>181.63</td><td>51.47</td><td>178.54</td><td>82.35</td><td>176.18</td><td>113.23</td><td>174.19</td><td>144.11</td><td>172.43</td><td>174.99</td><td>170.84</td><td>205.88</td><td>169.38</td><td>236.76</td><td>168.02</td><td>267.64</td></tr> <tr><td>1000</td><td>202.64</td><td>57.19</td><td>199.55</td><td>91.50</td><td>197.19</td><td>125.81</td><td>195.19</td><td>160.13</td><td>193.44</td><td>194.44</td><td>191.85</td><td>228.75</td><td>190.39</td><td>263.06</td><td>189.03</td><td>297.38</td></tr> <tr><td>1100</td><td>223.64</td><td>62.91</td><td>220.56</td><td>100.65</td><td>218.19</td><td>138.39</td><td>216.20</td><td>176.14</td><td>214.44</td><td>213.68</td><td>212.86</td><td>251.63</td><td>211.39</td><td>289.37</td><td>210.04</td><td>327.11</td></tr> <tr><td>1200</td><td>244.65</td><td>68.63</td><td>241.57</td><td>109.80</td><td>239.20</td><td>150.98</td><td>237.21</td><td>192.15</td><td>235.45</td><td>233.33</td><td>233.86</td><td>274.50</td><td>232.40</td><td>315.68</td><td>231.04</td><td>356.85</td></tr> <tr><td>1300</td><td>265.66</td><td>74.34</td><td>262.58</td><td>118.95</td><td>260.21</td><td>163.56</td><td>258.22</td><td>208.16</td><td>256.46</td><td>252.77</td><td>254.87</td><td>297.38</td><td>253.41</td><td>341.98</td><td>252.05</td><td>386.59</td></tr> <tr><td>1400</td><td>286.67</td><td>80.06</td><td>283.58</td><td>128.10</td><td>281.22</td><td>176.14</td><td>279.22</td><td>224.18</td><td>277.47</td><td>272.21</td><td>275.88</td><td>320.25</td><td>274.42</td><td>368.29</td><td>273.06</td><td>416.33</td></tr> <tr><td>600</td><td>137.87</td><td>39.77</td><td>134.46</td><td>63.63</td><td>131.84</td><td>87.50</td><td>129.64</td><td>111.36</td><td>127.69</td><td>135.22</td><td>125.94</td><td>159.09</td><td>124.32</td><td>182.95</td><td>122.82</td><td>206.81</td></tr> <tr><td>700</td><td>162.22</td><td>46.40</td><td>158.81</td><td>74.24</td><td>156.19</td><td>102.08</td><td>153.99</td><td>129.92</td><td>152.04</td><td>157.76</td><td>150.29</td><td>185.60</td><td>148.67</td><td>213.44</td><td>147.17</td><td>241.28</td></tr> <tr><td>800</td><td>186.57</td><td>53.03</td><td>183.16</td><td>84.85</td><td>180.54</td><td>116.66</td><td>178.34</td><td>148.48</td><td>176.39</td><td>180.30</td><td>174.64</td><td>212.11</td><td>173.02</td><td>243.93</td><td>171.52</td><td>275.75</td></tr> <tr><td>900</td><td>210.92</td><td>59.66</td><td>207.51</td><td>95.45</td><td>204.89</td><td>131.25</td><td>202.69</td><td>167.04</td><td>200.74</td><td>202.83</td><td>198.99</td><td>238.63</td><td>197.37</td><td>274.42</td><td>195.87</td><td>310.22</td></tr> FRB-400 <tr><td rowspan="6">FRB-400</td><td>1000</td><td>235.27</td><td>66.29</td><td>231.86</td><td>106.06</td><td>229.24</td><td>145.83</td><td>227.04</td><td>185.60</td><td>225.09</td><td>225.37</td><td>223.34</td><td>265.14</td><td>221.72</td><td>304.92</td><td>220.22</td><td>344.69</td></tr> <tr><td>1100</td><td>259.62</td><td>72.91</td><td>256.21</td><td>116.66</td><td>253.59</td><td>160.41</td><td>251.39</td><td>204.16</td><td>249.44</td><td>247.91</td><td>247.69</td><td>291.66</td><td>246.07</td><td>335.41</td><td>244.57</td><td>379.16</td></tr> <tr><td>1200</td><td>283.97</td><td>79.54</td><td>280.56</td><td>127.27</td><td>277.94</td><td>174.99</td><td>275.74</td><td>222.72</td><td>273.79</td><td>270.45</td><td>272.04</td><td>318.17</td><td>270.42</td><td>365.90</td><td>268.92</td><td>413.62</td></tr>																		FRB-250	830	50.02	14.40	48.83	23.03	47.92	31.67	47.15	40.31	46.48	48.95	45.87	57.59	45.30	66.22	44.78	74.86	880	53.21	15.26	52.02	24.42	51.11	33.58	50.34	42.74	49.66	51.90	49.05	61.06	48.49	70.21	47.97	79.37	930	56.39	16.13	55.20	25.81	54.29	35.49	53.53	45.17	52.85	54.85	52.24	64.52	51.68	74.20	51.15	83.88	990	60.21	17.17	59.03	27.48	58.12	37.78	57.35	48.08	56.67	58.38	56.06	68.69	55.50	78.99	54.97	89.29	1050	64.04	18.21	62.85	29.14	61.94	40.07	61.17	51.00	60.50	61.92	59.88	72.85	59.32	83.78	58.80	94.71	1110	67.86	19.25	66.67	30.81	65.76	42.36	64.99	53.91	64.32	65.46	63.71	77.01	63.14	88.57	62.62	100.12	1180	72.32	20.47	71.13	32.75	70.22	45.03	69.46	57.31	68.78	69.59	68.17	81.87	67.60	94.15	67.08	106.43	1250	76.78	21.68	75.59	34.69	74.68	47.70	73.92	60.71	73.24	73.72	72.63	86.73	72.06	99.74	71.54	112.75	1320	81.24	22.90	80.05	36.63	79.14	50.37	78.38	64.11	77.70	77.85	77.09	91.58	76.53	105.32	76.00	119.06	1390	85.70	24.11	84.51	38.58	83.60	53.04	82.84	67.51	82.16	81.97	81.55	96.44	80.99	110.91	80.46	125.37	1470	90.80	25.50	89.61	40.80	88.70	56.10	87.93	71.39	87.26	86.69	86.65	101.99	86.08	117.29	85.56	132.59	FRB-300A	830	66.52	19.20	64.86	30.71	63.59	42.23	62.52	53.75	61.57	65.26	60.72	76.78	59.94	88.30	59.21	99.82	880	70.76	20.35	69.11	32.56	67.84	44.77	66.77	56.99	65.82	69.20	64.97	81.41	64.18	93.62	63.45	105.83	930	75.01	21.51	73.36	34.41	72.09	47.32	71.01	60.22	70.07	73.13	69.22	86.03	68.43	98.94	67.70	111.84	990	80.11	22.90	78.45	36.63	77.18	50.37	76.11	64.11	75.17	77.85	74.31	91.58	73.53	105.32	72.80	119.06	1050	85.21	24.28	83.55	38.85	82.28	53.42	81.21	67.99	80.27	82.56	79.41	97.13	78.63	111.70	77.90	126.27	1110	90.30	25.67	88.65	41.07	87.38	56.48	86.31	71.88	85.36	87.28	84.51	102.68	83.72	118.09	82.99	133.49	1180	96.25	27.29	94.60	43.66	93.32	60.04	92.25	76.41	91.31	92.79	90.46	109.16	89.67	125.53	88.94	141.91	1250	102.20	28.91	100.54	46.25	99.27	63.60	98.20	80.95	97.26	98.29	96.40	115.64	95.62	132.98	94.89	150.33	1320	108.15	30.53	106.49	48.84	105.22	67.16	104.15	85.48	103.20	103.79	102.35	122.11	101.57	140.43	100.84	158.75	1390	114.09	32.15	112.44	51.43	111.17	70.72	110.09	90.01	109.15	109.30	108.30	128.59	107.51	147.88	106.78	167.16	1470	120.89	34.00	119.23	54.40	117.96	74.79	116.89	95.19	115.95	115.59	115.09	135.99	114.31	156.39	113.58	176.78	FRB-300	800	101.28	29.11	98.93	46.58	97.12	64.05	95.60	81.52	94.26	98.99	93.05	116.46	91.94	133.92	90.90	151.39	900	114.64	32.75	112.30	52.40	110.49	72.06	108.97	91.71	107.63	111.36	106.42	131.01	105.31	150.66	104.27	170.32	1000	128.01	36.39	125.66	58.23	123.86	80.06	122.34	101.90	121.00	123.73	119.79	145.57	118.68	167.40	117.64	189.24	1100	141.38	40.05	139.03	64.05	137.23	88.07	135.71	112.09	134.37	136.11	133.16	160.13	132.05	184.14	131.01	208.16	1200	154.75	43.67	152.40	69.87	150.60	96.08	149.08	122.28	147.74	148.48	146.53	174.68	145.41	200.89	144.38	227.09	1300	168.12	47.31	165.77	75.70	163.97	104.08	162.45	132.47	161.11	160.85	159.90	189.24	158.78	217.63	157.75	246.01	1400	181.49	50.95	179.14	81.52	177.34	112.09	175.82	142.66	174.48	173.23	173.27	203.80	172.15	234.37	171.12	264.94	600	118.60	34.31	115.52	54.90	113.16	75.49	111.16	96.08	109.40	116.66	107.82	137.25	106.36	157.84	105.00	178.43	700	139.61	40.03	136.53	64.05	134.16	88.07	132.17	112.09	130.41	136.11	128.82	160.13	127.36	184.14	126.00	208.16	800	160.62	45.75	157.54	73.20	155.17	100.65	153.18	128.10	151.42	155.55	149.83	183.00	148.37	210.45	147.01	237.90	FRB-350	900	181.63	51.47	178.54	82.35	176.18	113.23	174.19	144.11	172.43	174.99	170.84	205.88	169.38	236.76	168.02	267.64	1000	202.64	57.19	199.55	91.50	197.19	125.81	195.19	160.13	193.44	194.44	191.85	228.75	190.39	263.06	189.03	297.38	1100	223.64	62.91	220.56	100.65	218.19	138.39	216.20	176.14	214.44	213.68	212.86	251.63	211.39	289.37	210.04	327.11	1200	244.65	68.63	241.57	109.80	239.20	150.98	237.21	192.15	235.45	233.33	233.86	274.50	232.40	315.68	231.04	356.85	1300	265.66	74.34	262.58	118.95	260.21	163.56	258.22	208.16	256.46	252.77	254.87	297.38	253.41	341.98	252.05	386.59	1400	286.67	80.06	283.58	128.10	281.22	176.14	279.22	224.18	277.47	272.21	275.88	320.25	274.42	368.29	273.06	416.33	600	137.87	39.77	134.46	63.63	131.84	87.50	129.64	111.36	127.69	135.22	125.94	159.09	124.32	182.95	122.82	206.81	700	162.22	46.40	158.81	74.24	156.19	102.08	153.99	129.92	152.04	157.76	150.29	185.60	148.67	213.44	147.17	241.28	800	186.57	53.03	183.16	84.85	180.54	116.66	178.34	148.48	176.39	180.30	174.64	212.11	173.02	243.93	171.52	275.75	900	210.92	59.66	207.51	95.45	204.89	131.25	202.69	167.04	200.74	202.83	198.99	238.63	197.37	274.42	195.87	310.22	FRB-400	1000	235.27	66.29	231.86	106.06	229.24	145.83	227.04	185.60	225.09	225.37	223.34	265.14	221.72	304.92	220.22	344.69	1100	259.62	72.91	256.21	116.66	253.59	160.41	251.39	204.16	249.44	247.91	247.69	291.66	246.07	335.41	244.57	379.16	1200	283.97	79.54	280.56	127.27	277.94	174.99	275.74	222.72	273.79	270.45	272.04	318.17	270.42	365.90
FRB-250	830	50.02	14.40	48.83	23.03	47.92	31.67	47.15	40.31	46.48	48.95	45.87	57.59	45.30	66.22	44.78	74.86																																																																																																																																																																																																																																																																																																																																																																																																																																																																																																																																																																																																																																																																																																																																																																																																		
	880	53.21	15.26	52.02	24.42	51.11	33.58	50.34	42.74	49.66	51.90	49.05	61.06	48.49	70.21	47.97	79.37																																																																																																																																																																																																																																																																																																																																																																																																																																																																																																																																																																																																																																																																																																																																																																																																		
	930	56.39	16.13	55.20	25.81	54.29	35.49	53.53	45.17	52.85	54.85	52.24	64.52	51.68	74.20	51.15	83.88																																																																																																																																																																																																																																																																																																																																																																																																																																																																																																																																																																																																																																																																																																																																																																																																		
	990	60.21	17.17	59.03	27.48	58.12	37.78	57.35	48.08	56.67	58.38	56.06	68.69	55.50	78.99	54.97	89.29																																																																																																																																																																																																																																																																																																																																																																																																																																																																																																																																																																																																																																																																																																																																																																																																		
	1050	64.04	18.21	62.85	29.14	61.94	40.07	61.17	51.00	60.50	61.92	59.88	72.85	59.32	83.78	58.80	94.71																																																																																																																																																																																																																																																																																																																																																																																																																																																																																																																																																																																																																																																																																																																																																																																																		
	1110	67.86	19.25	66.67	30.81	65.76	42.36	64.99	53.91	64.32	65.46	63.71	77.01	63.14	88.57	62.62	100.12																																																																																																																																																																																																																																																																																																																																																																																																																																																																																																																																																																																																																																																																																																																																																																																																		
	1180	72.32	20.47	71.13	32.75	70.22	45.03	69.46	57.31	68.78	69.59	68.17	81.87	67.60	94.15	67.08	106.43																																																																																																																																																																																																																																																																																																																																																																																																																																																																																																																																																																																																																																																																																																																																																																																																		
	1250	76.78	21.68	75.59	34.69	74.68	47.70	73.92	60.71	73.24	73.72	72.63	86.73	72.06	99.74	71.54	112.75																																																																																																																																																																																																																																																																																																																																																																																																																																																																																																																																																																																																																																																																																																																																																																																																		
	1320	81.24	22.90	80.05	36.63	79.14	50.37	78.38	64.11	77.70	77.85	77.09	91.58	76.53	105.32	76.00	119.06																																																																																																																																																																																																																																																																																																																																																																																																																																																																																																																																																																																																																																																																																																																																																																																																		
	1390	85.70	24.11	84.51	38.58	83.60	53.04	82.84	67.51	82.16	81.97	81.55	96.44	80.99	110.91	80.46	125.37																																																																																																																																																																																																																																																																																																																																																																																																																																																																																																																																																																																																																																																																																																																																																																																																		
1470	90.80	25.50	89.61	40.80	88.70	56.10	87.93	71.39	87.26	86.69	86.65	101.99	86.08	117.29	85.56	132.59																																																																																																																																																																																																																																																																																																																																																																																																																																																																																																																																																																																																																																																																																																																																																																																																			
FRB-300A	830	66.52	19.20	64.86	30.71	63.59	42.23	62.52	53.75	61.57	65.26	60.72	76.78	59.94	88.30	59.21	99.82																																																																																																																																																																																																																																																																																																																																																																																																																																																																																																																																																																																																																																																																																																																																																																																																		
	880	70.76	20.35	69.11	32.56	67.84	44.77	66.77	56.99	65.82	69.20	64.97	81.41	64.18	93.62	63.45	105.83																																																																																																																																																																																																																																																																																																																																																																																																																																																																																																																																																																																																																																																																																																																																																																																																		
	930	75.01	21.51	73.36	34.41	72.09	47.32	71.01	60.22	70.07	73.13	69.22	86.03	68.43	98.94	67.70	111.84																																																																																																																																																																																																																																																																																																																																																																																																																																																																																																																																																																																																																																																																																																																																																																																																		
	990	80.11	22.90	78.45	36.63	77.18	50.37	76.11	64.11	75.17	77.85	74.31	91.58	73.53	105.32	72.80	119.06																																																																																																																																																																																																																																																																																																																																																																																																																																																																																																																																																																																																																																																																																																																																																																																																		
	1050	85.21	24.28	83.55	38.85	82.28	53.42	81.21	67.99	80.27	82.56	79.41	97.13	78.63	111.70	77.90	126.27																																																																																																																																																																																																																																																																																																																																																																																																																																																																																																																																																																																																																																																																																																																																																																																																		
	1110	90.30	25.67	88.65	41.07	87.38	56.48	86.31	71.88	85.36	87.28	84.51	102.68	83.72	118.09	82.99	133.49																																																																																																																																																																																																																																																																																																																																																																																																																																																																																																																																																																																																																																																																																																																																																																																																		
	1180	96.25	27.29	94.60	43.66	93.32	60.04	92.25	76.41	91.31	92.79	90.46	109.16	89.67	125.53	88.94	141.91																																																																																																																																																																																																																																																																																																																																																																																																																																																																																																																																																																																																																																																																																																																																																																																																		
	1250	102.20	28.91	100.54	46.25	99.27	63.60	98.20	80.95	97.26	98.29	96.40	115.64	95.62	132.98	94.89	150.33																																																																																																																																																																																																																																																																																																																																																																																																																																																																																																																																																																																																																																																																																																																																																																																																		
	1320	108.15	30.53	106.49	48.84	105.22	67.16	104.15	85.48	103.20	103.79	102.35	122.11	101.57	140.43	100.84	158.75																																																																																																																																																																																																																																																																																																																																																																																																																																																																																																																																																																																																																																																																																																																																																																																																		
	1390	114.09	32.15	112.44	51.43	111.17	70.72	110.09	90.01	109.15	109.30	108.30	128.59	107.51	147.88	106.78	167.16																																																																																																																																																																																																																																																																																																																																																																																																																																																																																																																																																																																																																																																																																																																																																																																																		
1470	120.89	34.00	119.23	54.40	117.96	74.79	116.89	95.19	115.95	115.59	115.09	135.99	114.31	156.39	113.58	176.78																																																																																																																																																																																																																																																																																																																																																																																																																																																																																																																																																																																																																																																																																																																																																																																																			
FRB-300	800	101.28	29.11	98.93	46.58	97.12	64.05	95.60	81.52	94.26	98.99	93.05	116.46	91.94	133.92	90.90	151.39																																																																																																																																																																																																																																																																																																																																																																																																																																																																																																																																																																																																																																																																																																																																																																																																		
	900	114.64	32.75	112.30	52.40	110.49	72.06	108.97	91.71	107.63	111.36	106.42	131.01	105.31	150.66	104.27	170.32																																																																																																																																																																																																																																																																																																																																																																																																																																																																																																																																																																																																																																																																																																																																																																																																		
	1000	128.01	36.39	125.66	58.23	123.86	80.06	122.34	101.90	121.00	123.73	119.79	145.57	118.68	167.40	117.64	189.24																																																																																																																																																																																																																																																																																																																																																																																																																																																																																																																																																																																																																																																																																																																																																																																																		
	1100	141.38	40.05	139.03	64.05	137.23	88.07	135.71	112.09	134.37	136.11	133.16	160.13	132.05	184.14	131.01	208.16																																																																																																																																																																																																																																																																																																																																																																																																																																																																																																																																																																																																																																																																																																																																																																																																		
	1200	154.75	43.67	152.40	69.87	150.60	96.08	149.08	122.28	147.74	148.48	146.53	174.68	145.41	200.89	144.38	227.09																																																																																																																																																																																																																																																																																																																																																																																																																																																																																																																																																																																																																																																																																																																																																																																																		
	1300	168.12	47.31	165.77	75.70	163.97	104.08	162.45	132.47	161.11	160.85	159.90	189.24	158.78	217.63	157.75	246.01																																																																																																																																																																																																																																																																																																																																																																																																																																																																																																																																																																																																																																																																																																																																																																																																		
	1400	181.49	50.95	179.14	81.52	177.34	112.09	175.82	142.66	174.48	173.23	173.27	203.80	172.15	234.37	171.12	264.94																																																																																																																																																																																																																																																																																																																																																																																																																																																																																																																																																																																																																																																																																																																																																																																																		
	600	118.60	34.31	115.52	54.90	113.16	75.49	111.16	96.08	109.40	116.66	107.82	137.25	106.36	157.84	105.00	178.43																																																																																																																																																																																																																																																																																																																																																																																																																																																																																																																																																																																																																																																																																																																																																																																																		
	700	139.61	40.03	136.53	64.05	134.16	88.07	132.17	112.09	130.41	136.11	128.82	160.13	127.36	184.14	126.00	208.16																																																																																																																																																																																																																																																																																																																																																																																																																																																																																																																																																																																																																																																																																																																																																																																																		
	800	160.62	45.75	157.54	73.20	155.17	100.65	153.18	128.10	151.42	155.55	149.83	183.00	148.37	210.45	147.01	237.90																																																																																																																																																																																																																																																																																																																																																																																																																																																																																																																																																																																																																																																																																																																																																																																																		
FRB-350	900	181.63	51.47	178.54	82.35	176.18	113.23	174.19	144.11	172.43	174.99	170.84	205.88	169.38	236.76	168.02	267.64																																																																																																																																																																																																																																																																																																																																																																																																																																																																																																																																																																																																																																																																																																																																																																																																		
	1000	202.64	57.19	199.55	91.50	197.19	125.81	195.19	160.13	193.44	194.44	191.85	228.75	190.39	263.06	189.03	297.38																																																																																																																																																																																																																																																																																																																																																																																																																																																																																																																																																																																																																																																																																																																																																																																																		
	1100	223.64	62.91	220.56	100.65	218.19	138.39	216.20	176.14	214.44	213.68	212.86	251.63	211.39	289.37	210.04	327.11																																																																																																																																																																																																																																																																																																																																																																																																																																																																																																																																																																																																																																																																																																																																																																																																		
	1200	244.65	68.63	241.57	109.80	239.20	150.98	237.21	192.15	235.45	233.33	233.86	274.50	232.40	315.68	231.04	356.85																																																																																																																																																																																																																																																																																																																																																																																																																																																																																																																																																																																																																																																																																																																																																																																																		
	1300	265.66	74.34	262.58	118.95	260.21	163.56	258.22	208.16	256.46	252.77	254.87	297.38	253.41	341.98	252.05	386.59																																																																																																																																																																																																																																																																																																																																																																																																																																																																																																																																																																																																																																																																																																																																																																																																		
	1400	286.67	80.06	283.58	128.10	281.22	176.14	279.22	224.18	277.47	272.21	275.88	320.25	274.42	368.29	273.06	416.33																																																																																																																																																																																																																																																																																																																																																																																																																																																																																																																																																																																																																																																																																																																																																																																																		
	600	137.87	39.77	134.46	63.63	131.84	87.50	129.64	111.36	127.69	135.22	125.94	159.09	124.32	182.95	122.82	206.81																																																																																																																																																																																																																																																																																																																																																																																																																																																																																																																																																																																																																																																																																																																																																																																																		
	700	162.22	46.40	158.81	74.24	156.19	102.08	153.99	129.92	152.04	157.76	150.29	185.60	148.67	213.44	147.17	241.28																																																																																																																																																																																																																																																																																																																																																																																																																																																																																																																																																																																																																																																																																																																																																																																																		
	800	186.57	53.03	183.16	84.85	180.54	116.66	178.34	148.48	176.39	180.30	174.64	212.11	173.02	243.93	171.52	275.75																																																																																																																																																																																																																																																																																																																																																																																																																																																																																																																																																																																																																																																																																																																																																																																																		
	900	210.92	59.66	207.51	95.45	204.89	131.25	202.69	167.04	200.74	202.83	198.99	238.63	197.37	274.42	195.87	310.22																																																																																																																																																																																																																																																																																																																																																																																																																																																																																																																																																																																																																																																																																																																																																																																																		
FRB-400	1000	235.27	66.29	231.86	106.06	229.24	145.83	227.04	185.60	225.09	225.37	223.34	265.14	221.72	304.92	220.22	344.69																																																																																																																																																																																																																																																																																																																																																																																																																																																																																																																																																																																																																																																																																																																																																																																																		
	1100	259.62	72.91	256.21	116.66	253.59	160.41	251.39	204.16	249.44	247.91	247.69	291.66	246.07	335.41	244.57	379.16																																																																																																																																																																																																																																																																																																																																																																																																																																																																																																																																																																																																																																																																																																																																																																																																		
	1200	283.97	79.54	280.56	127.27	277.94	174.99	275.74	222.72	273.79	270.45	272.04	318.17	270.42	365.90	268.92	413.62																																																																																																																																																																																																																																																																																																																																																																																																																																																																																																																																																																																																																																																																																																																																																																																																		



Installation Dimensions (Horizontal Outlet Silencer)

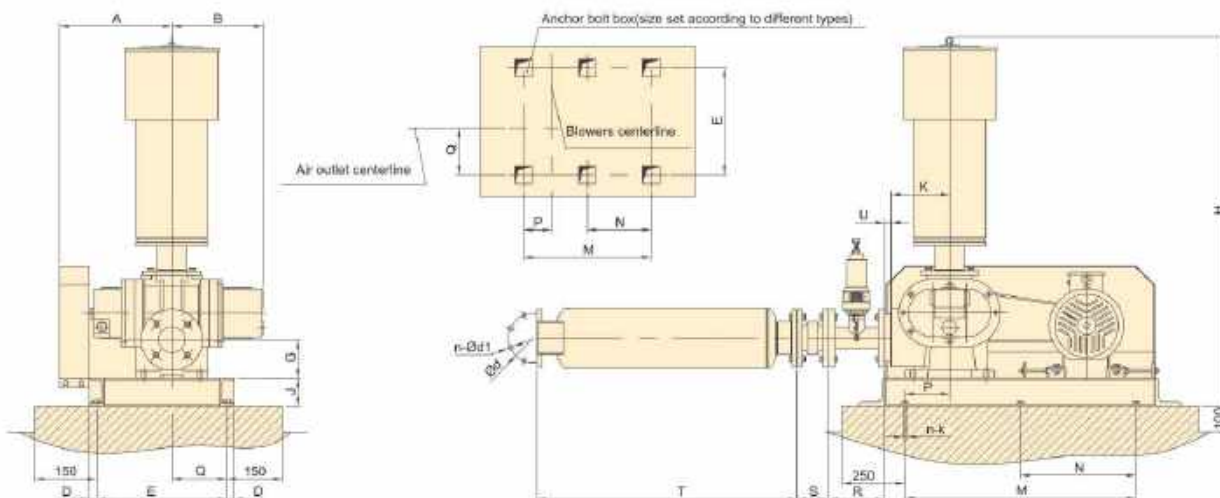

Unit(mm)

Type	A	B	D	E	G	H	J	K	M	N	P	Q	R	S	T	U	d	n-Ød1	n-k
FRB-32	132.5	173	20	290	93	313	56	95	400	-	20	137	-	-	-	96	-	-	4-M10x160
FRB-40	235	238	25	350	104	741	56	140	500	-	98	95	150	-	-	18	110	4-Ø18	4-M12x160
FRB-50	300	278	20	412	103.5	921	80	140	520	-	93	211	150	105	595	18	125	4-Ø18	4-M12x160
FRB-65	323	308	20	412	104	924	80	152	520	-	93	188.5	150	115	595	18	145	4-Ø18	4-M12x160
FRB-80	383	340	20	482	106.5	1241	80	180	700	-	80	238	180	135	795	22	160	8-Ø18	4-M12x160
FRB-100	426	390	20	482	110	1245	80	180	700	-	98	195	180	150	795	22	180	8-Ø18	4-M12x160
FRB-125A	485	370.5	24	602	135	1840	100	250	950	-	178	291	250	165	1260	22	210	8-Ø18	4-M16x220
FRB-125	505	430.5	24	602	157.5	1835	100	262	950	-	182	271	250	165	1260	22	210	8-Ø18	4-M16x220
FRB-150	564	485.5	24	602	163.5	1860	100	250	950	-	182	212	250	180	1260	22	240	8-Ø23	4-M16x220
FRB-200A	519.5	465	30	790	198	2285	160	358	1300	650	313	480.5	250	210	1645	25	295	8-Ø23	6-M20x300
FRB-200	565	515	30	940	194	2285	160	345	1300	650	310	580	250	210	1645	25	295	8-Ø23	6-M20x300
FRB-250	695	590	30	940	216	2520	160	356	1400	700	270	490	250	230	1750	38	350	12-Ø23	6-M20x300
FRB-300A	805	723	30	940	255	2660	160	360	1500	750	248	470	300	250	1850	38	400	12-Ø23	6-M20x300
FRB-300	840	627.5	35	1030	300	2955	250	510	2000	1000	321	487	300	250	1850	38	400	12-Ø23	6-M20x300
FRB-350	946	767	35	1110	300	3367	250	510	2000	1000	325	550	350	255	2500	38	460	16-Ø23	6-M30x400
FRB-400	1020	837	35	1110	300	3663	250	510	2000	1000	325	440	350	255	2700	42	515	16-Ø26	6-M30x400

Note: For FRB-200A and FRB200, if the motor power is higher than 90kW (include 90kw), Please check with us the baseplate dimension.

Anchor bolt

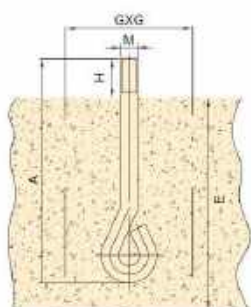

Unit(mm)

M Anchor bolt GB799-88	A	H	E	GxG	Application type
M10	160	32	224	100x100	FRB-32
M12	160	36	224	100x100	FRB-40,50,65,80,100
M16	220	45	275	120x120	FRB-125(A), 150
M20	300	55	345	150x150	FRB-200(A), 250, 300(A)
M30	400	72	428	200x200	FRB-350, 400

- Note: 1. The note E on the drawing is the minimum size, it shall be deepened properly according to the soil condition in the installation place.
2. GxG is the size of the preformed holes for the secondary casting.



Installation Dimensions (Vertical Outlet Silencer)

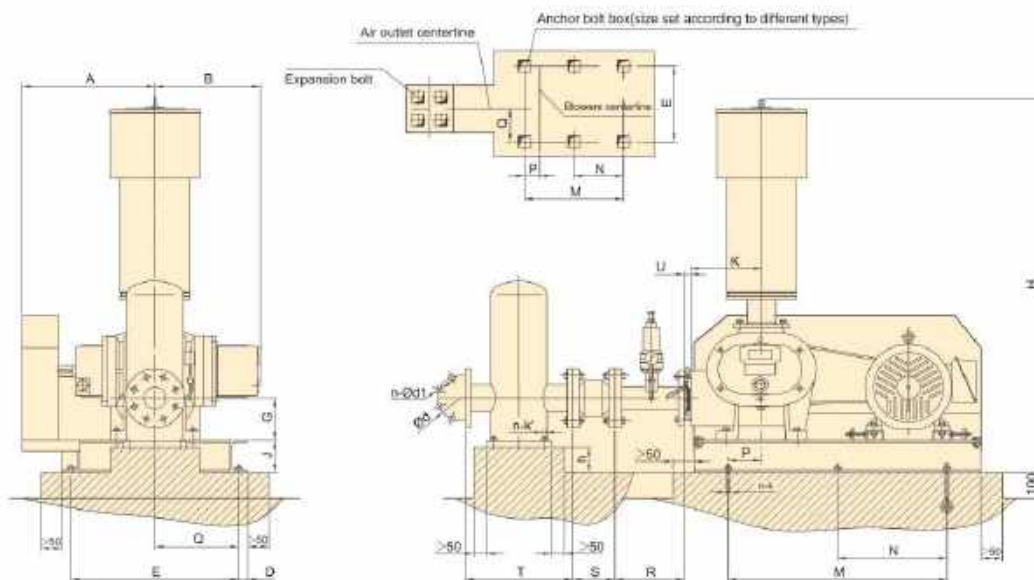

Unit(mm)

Type	A	B	D	E	G	H	h	J	K	M	N	P	Q	R	S	T	U	d	n-Ød1	n-k	n-k'
FRB-50	300	278	20	412	103.5	921	63.5	80	140	520	-	93	211	150	105	300	18	125	4-Ø18	4-M12x160	4-M12x120
FRB-65	323	308	20	412	104	924	54	80	152	520	-	93	188.5	150	115	350	18	145	4-Ø18	4-M12x160	4-M12x120
FRB-80	383	340	20	482	106.5	1241	41.5	80	180	700	-	80	238	180	135	400	22	160	8-Ø18	4-M12x160	4-M12x120
FRB-100	426	390	20	482	110	1245	35	80	180	700	-	98	195	180	150	450	22	180	8-Ø18	4-M12x160	4-M12x120
FRB-125A	485	370.5	24	602	135	1840	45	100	250	950	-	178	291	250	165	500	22	210	8-Ø18	4-M16x220	4-M12x120
FRB-125	505	430.5	24	602	157.5	1835	67.5	100	262	950	-	182	271	250	165	500	22	210	8-Ø18	4-M16x220	4-M12x120
FRB-150	564	485.5	24	602	163.5	1860	53.5	100	250	950	-	182	212	250	180	600	22	240	8-Ø23	4-M16x220	4-M12x120
FRB-200A	519.5	465	30	790	198	2285	102	160	358	1300	650	313	480.5	250	210	650	25	295	8-Ø23	6-M20x300	4-M12x120
FRB-200	565	515	30	940	194	2285	98	160	345	1300	650	310	580	250	210	650	25	295	8-Ø23	6-M20x300	4-M12x120

Note: 1. Above DN250 (included) diameter of FRB blower, can not be configured with vertical outlet silencer.

2. For FRB-200A and FRB-200, if the motor power is higher than 90kW (include 90kW), please check with us the baseplate dimension

Relief valve

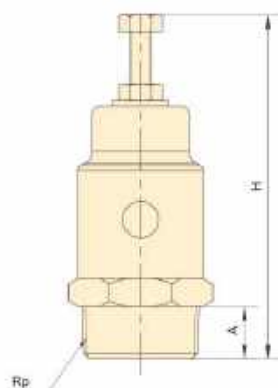

Unit(mm)

Type	A	H	Application type	Weight (kg)
SV 1/2"	15	91.5	FRB-32	0.3
SV1 1/4"	19	145	FRB-40,50,65,80	0.3
SV2"	24	185	FRB-100,125(A), 150	1
SV3"	30	230	FRB-200(A), 250	1.6
SV100	90	490	FRB-300(A)	29
SV150	95	490	FRB-350, 400	38.4

Note: Type SV100/SV150 is connect with flange. Refer to JB/T 1.0Mpa.

Unit(mm)

Suction silencer

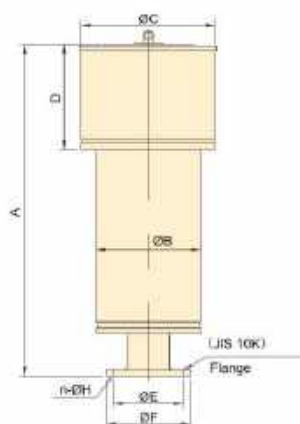

Type	A	B	C	D	E	F	n-ØH	Weight (kg)	Application type
SS32	113	-	105	-	-	-	-	4	FRB-32
SS40	400	133	150	220	105	140	4-Ø14	7	FRB-40
SS50	550	133	150	220	120	155	4-Ø19	10	FRB-50
SS65	550	159	190	280	140	175	4-Ø19	12	FRB-65
SS80	820	219	245	280	150	185	8-Ø19	21	FRB-80
SS100	820	245	273	330	175	210	8-Ø19	27	FRB-100
SS125	1310	273	310	350	210	250	8-Ø23	45	FRB-125A
SS150	1310	299	340	370	240	280	8-Ø23	52	FRB-150
SS200	1500	330	380	370	290	330	12-Ø23	81	FRB-200A
SS250	1700	400	480	550	355	400	12-Ø25	98	FRB-250
SS300	1825	500	600	650	400	445	16-Ø25	135	FRB-300A
SS350	2237	550	676	700	445	490	16-Ø25	200	FRB-350
SS400	2533	600	720	750	510	560	16-Ø27	250	FRB-400

Note: Type SS32 is connect with Rp thread standard 1".

Horizontal outlet silencer

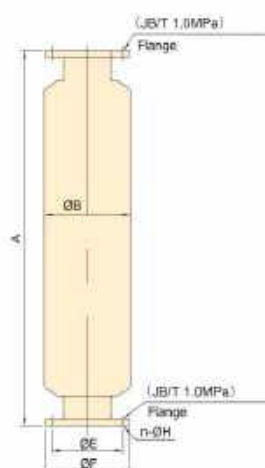

Unit(mm)

Type	A	B	E	F	n-ØH	Weight (kg)	Application type
DS50	595	159	125	160	4-Ø18	12	FRB-50
DS65	595	159	145	180	4-Ø18	13.5	FRB-65
DS80	795	219	160	195	8-Ø18	24	FRB-80
DS100	795	219	180	215	8-Ø18	25	FRB-100
DS125	1260	290	210	245	8-Ø18	48	FRB-125A
DS150	1260	290	240	280	8-Ø23	51	FRB-150
DS200	1645	356	295	335	8-Ø23	79	FRB-200A
DS250	1750	405	350	390	12-Ø23	98	FRB-250
DS300	1850	484	400	440	12-Ø23	140	FRB-300A
DS350	2500	560	460	500	16-Ø23	280	FRB-350
DS400	2700	610	515	565	16-Ø26	340	FRB-400

Vertical outlet silencer

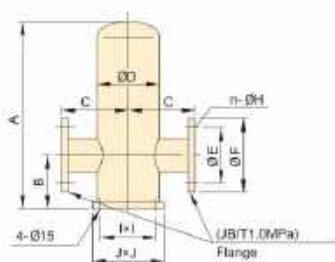

Unit(mm)

Type	A	B	C	D	E	F	n-ØH	I	J	Weight (kg)	Application type
VDS50	420	120	150	140	125	160	4-Ø18	125	160	19.0	FRB-50
VDS65	480	130	175	191	145	180	4-Ø18	170	210	27.0	FRB-65
VDS80	595	145	200	216	160	195	8-Ø18	190	235	36.9	FRB-80
VDS100	660	155	225	267	180	215	8-Ø18	230	280	51.8	FRB-100
VDS125	800	190	250	280	210	245	8-Ø18	240	300	65.9	FRB-125A
VDS150	920	210	300	356	240	280	8-Ø22	290	376	99.6	FRB-150
VDS200	1050	256	325	406	295	335	8-Ø22	350	425	131.5	FRB-200A

Note: Above DN250 (included) diameter of FRB blower, can not be configured with vertical outlet silencer.



Installation Dimensions (Vertical Outlet Silencer)

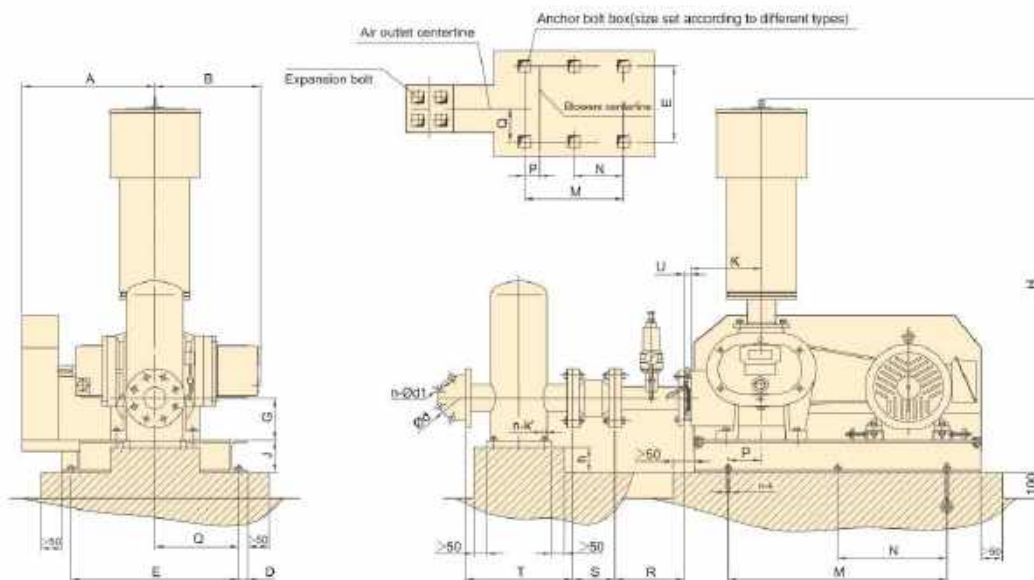

Unit(mm)

Type	A	B	D	E	G	H	h	J	K	M	N	P	Q	R	S	T	U	d	n-Ød1	n-k	n-k'
FRB-50	300	278	20	412	103.5	921	63.5	80	140	520	-	93	211	150	105	300	18	125	4-Ø18	4-M12x160	4-M12x120
FRB-65	323	308	20	412	104	924	54	80	152	520	-	93	188.5	150	115	350	18	145	4-Ø18	4-M12x160	4-M12x120
FRB-80	383	340	20	482	106.5	1241	41.5	80	180	700	-	80	238	180	135	400	22	160	8-Ø18	4-M12x160	4-M12x120
FRB-100	426	390	20	482	110	1245	35	80	180	700	-	98	195	180	150	450	22	180	8-Ø18	4-M12x160	4-M12x120
FRB-125A	485	370.5	24	602	135	1840	45	100	250	950	-	178	291	250	165	500	22	210	8-Ø18	4-M16x220	4-M12x120
FRB-125	505	430.5	24	602	157.5	1835	67.5	100	262	950	-	182	271	250	165	500	22	210	8-Ø18	4-M16x220	4-M12x120
FRB-150	564	485.5	24	602	163.5	1860	53.5	100	250	950	-	182	212	250	180	600	22	240	8-Ø23	4-M16x220	4-M12x120
FRB-200A	519.5	465	30	790	198	2285	102	160	358	1300	650	313	480.5	250	210	650	25	295	8-Ø23	6-M20x300	4-M12x120
FRB-200	565	515	30	940	194	2285	98	160	345	1300	650	310	580	250	210	650	25	295	8-Ø23	6-M20x300	4-M12x120

Note: 1. Above DN250 (included) diameter of FRB blower, can not be configured with vertical outlet silencer.

2. For FRB-200A and FRB-200, if the motor power is higher than 90kW (included 90kW), please check with us the baseplate dimension.

Relief valve

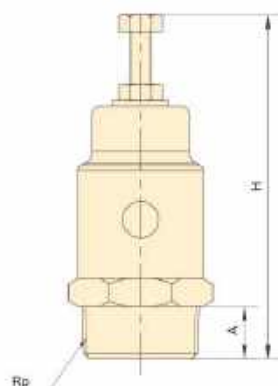

Unit(mm)

Type	A	H	Application type	Weight (kg)
SV 1/1'	15	91.5	FRB-32	0.3
SV1 1/1'	19	145	FRB-40,50,65,80	0.3
SV2'	24	185	FRB-100, 125(A), 150	1
SV3'	30	230	FRB-200(A), 250	1.6
SV100	90	490	FRB-300(A)	29
SV150	95	490	FRB-350, 400	38.4

Note: Type SV100/SV150 is connect with flange. Refer to JB/T 1.0MPa.

For further details, please fulfill the chart below.

Customer _____ Undertaker _____

Name of project _____ Address of project _____

Telephone _____ Fax _____

* Usage	<input type="checkbox"/> Compression		<input type="checkbox"/> Vacuum	
* Local condition	Elevation		Max relative humidity %	
	Local atmospheric pressure		Max air temperature (°C)	
* Gas character	Name		Temperature (°C)	
	Constituents		Ratio of constituent	
Blower's parameter	* Capacity (m ³ /min)		Diameter (mm)	
	* Pressure (mmAq)		Speed (r/min)	
Motor's parameter	Type		voltage (V)	
	Power (kW)		Frequency (Hz)	
	Pole		Others	
Location	<input type="checkbox"/> Indoor install	<input type="checkbox"/> Camping outdoor install	<input type="checkbox"/> Others _____	
* Driving mode	<input type="checkbox"/> Belt-driven(Standard)		<input type="checkbox"/> Direct drive	
Other requirement				

Notes: 1. Please fill in the parameter lists as complete as possible.
 2. The item with "*" must be filled.



Applications

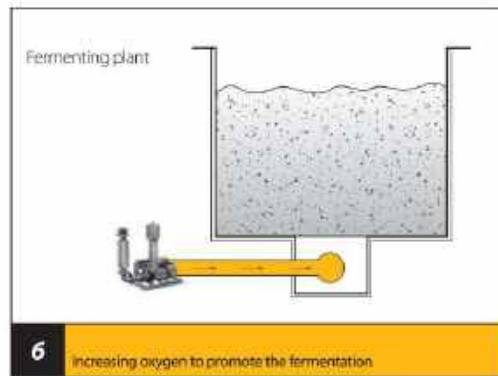
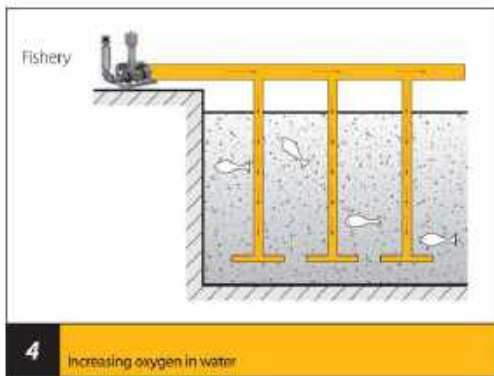
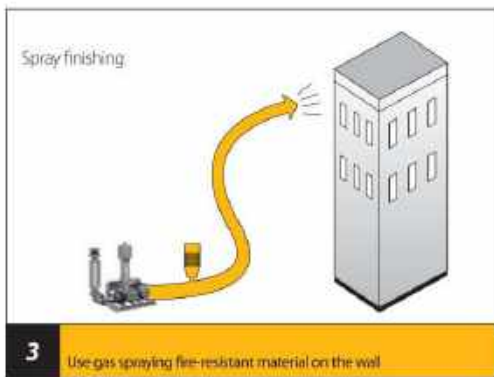
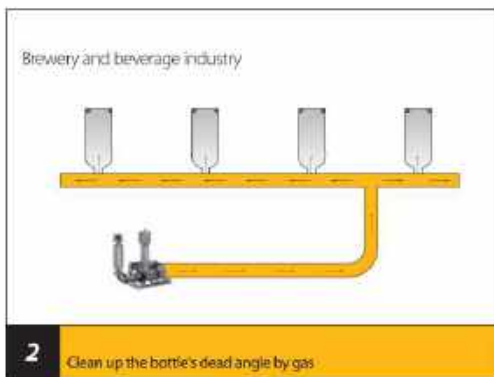
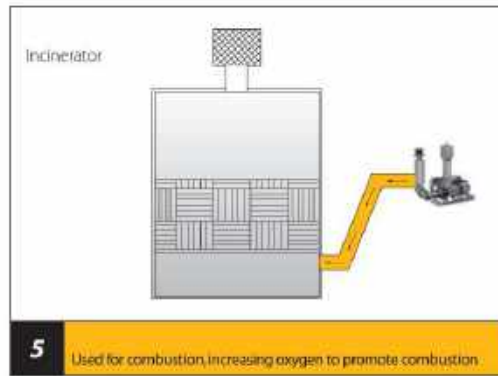
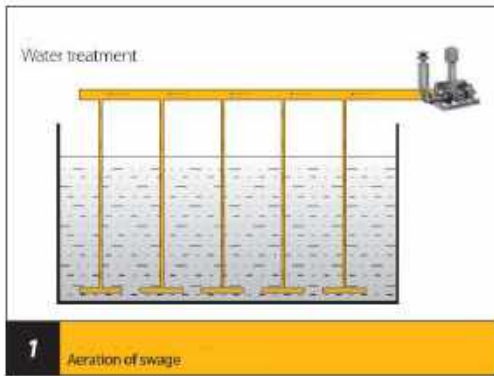

← Incinerator

Water treatment

Brewery and beverage industry

Spray finishing

Fishery

← Fermenting plant





Car washing

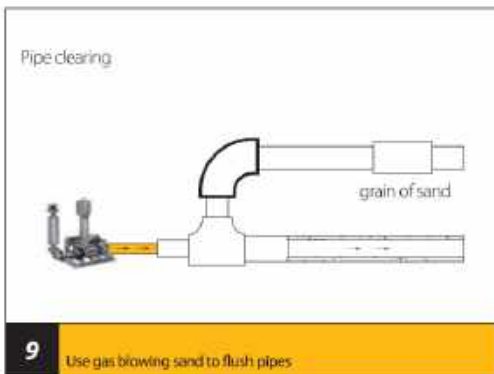

Pipe clearing

Electroplate factory

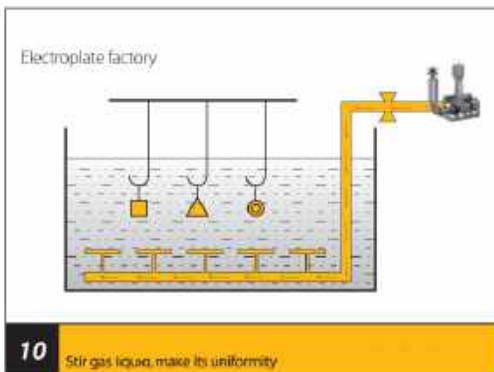

Sauna

Conveying

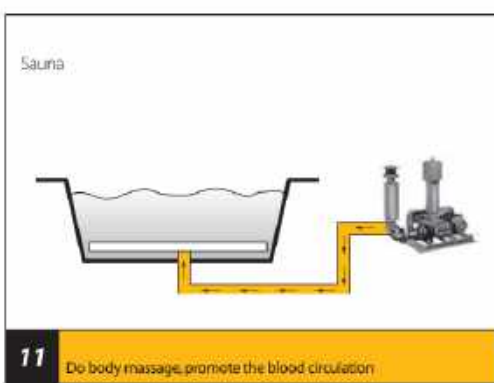

Paper mill

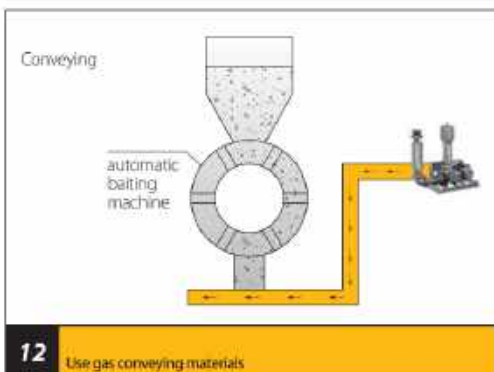
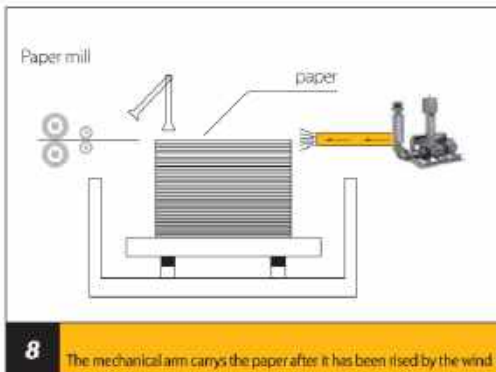



GFLUGO

FRB Series
Three-lobe Roots Blower