

# New Generation Compact Series R410A

076-340 MBH



**Ducted Split with Hermetic Compressor Tropical**

**50 Hz**

# TABLE OF CONTENT

<b>ABOUT THE COMPANY</b>	<b>02</b>
<b>INTRODUCTION</b>	<b>03</b>
<b>NOMENCLATURE</b>	<b>03</b>
<b>UNIT RATING SUMMARY</b>	<b>04</b>
<b>OUTSTANDING FEATURES</b>	<b>05</b>
<b>STANDARD SPECIFICATIONS</b>	<b>06</b>
<b>OPTIONAL SPECIFICATIONS</b>	<b>07</b>
<b>SELECTION PROCEDURE</b>	<b>08</b>
<b>GENERAL DATA</b>	<b>09</b>
<b>PERFORMANCE DATA TABLES</b>	<b>11</b>
<b>UNIT ELECTRICAL DATA</b>	<b>16</b>
<b>FAN PERFORMANCE</b>	<b>17</b>
<b>UNIT DIMENSIONS</b>	<b>19</b>
<b>WIRING DIAGRAMS</b>	<b>38</b>

## ABOUT THE COMPANY

Refrigeration Industries & Storage and Oil Services Company, occupies a leading position as one of the largest industrial companies in Kuwait which was established in 1973. It plays a proactive role in providing various services and diverse activities such as manufacturing, storage, and oil services to meet the needs of customers both inside and outside Kuwait.

Since its inception, RIC has been committed to excellence and advancing its progress, leading to the establishment of the brand (Coolex) in 1986, a true milestone in the Kuwaiti market as the first in the region in the sector of manufacturing air conditioning systems and cooling solutions.

Furthermore, the company has consistently empowered its workforce, enhanced safety and competitiveness, and utilized innovative technologies to launch new products that meet the needs of various sectors, contributing to company's expansion and supporting growth and prosperity.

To ensure the highest performance in the future, RIC harnesses its continuous research to enhance efficiency and quality, while continuing its efforts to manufacture products capable of adapting to climate, environmental, and energy challenges.



## Facts throughout the years

- 1973 Warehouses were established by Amiri Decree.
- 1979 RIC Constructed the Medical Cold Stores Complex, the world's largest at that time.
- 1980 RIC Air Conditioning manufacturing plant set up in Sulaibya.
- 1981 Production of Package & Mini-Split A/Cs started under York-Gulf.
- 1984 RIC was listed in Kuwait Stock Exchange.
- 1986 COOLEX brand Production Launched.
- 1991 RIC rebuilt the manufacturing plant destroyed during the war.
- 1997 Achieved ISO Certification ISO 9001:1994.
- 2002 ETL Designed testing lab became fully operational.
- 2004 Privatization of RIC.
- 2010 COOLEX becomes the first A/C Unit to Pass MEW's new regulations.
- 2010 RIC Factory Renovation and Expansion into neighboring countries.
- 2012 Achieved UL & AHRI Certification for Coolex Units.
- 2014 Achieved SASO Certification for Concealed Ducted Split Series.
- 2014 Achieved EUROVENT Certification for Air Handling Units AHU.
- 2014 Achieved UL Certification for Air Cooled Chillers.
- 2015 Achieved ISO 17025 Certification for Psychrometric Laboratory.
- 2016 Achieved Energy Efficiency Certification for Concealed Ducted Split Series & Rooftop Package units (Kingdom of Bahrain).
- 2016 Acquisition of Gulf Paramount for Electrical Services Company.
- 2021 Acquisition of Kuwait Pipes Industries & Oil Services factory, resulting in a change of the company's name from Refrigeration Industries & Storage Co. to Refrigeration Industries & Storage and Oil Services Co.

**INTRODUCTION**

COOLEX High Efficiency Ducted Split Units are designed specifically for tropical operation with high performance, low power consumption, easy installation and low noise operation.

COOLEX Ducted Split Units can be used for cooling or heating with optional duct electric heater.

**NOMENCLATURE**

**NGC F 175 C 2**

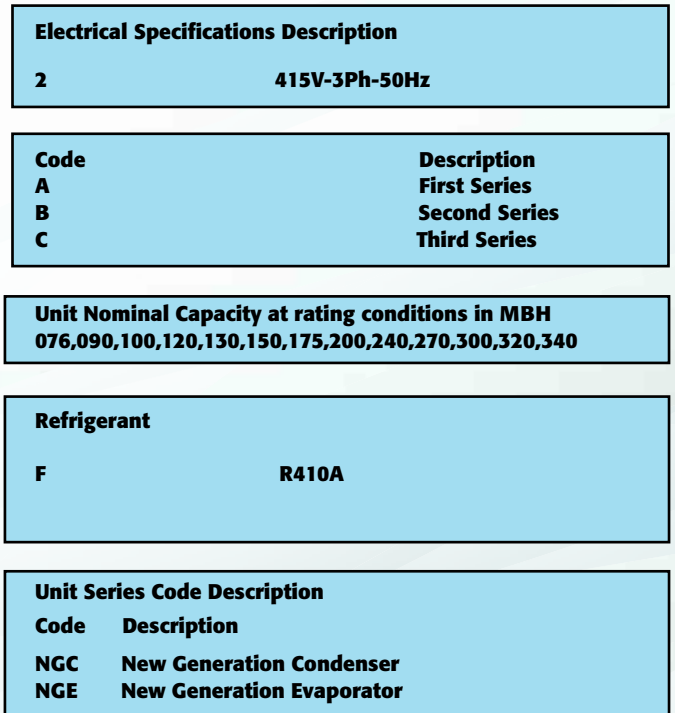

## UNIT RATING SUMMARY

Model	Air Flow (MAX)	Ambient temp 95°F				Ambient temp 115°F				Ambient temp 118.4°F			
		Cooling Capacity	Total Power	kW/Ton	EER	Cooling Capacity	Total Power	kW/Ton	EER	Cooling Capacity	Total Power	kW/Ton	EER
	(CFM)	(MBH)	(kW)			(MBH)	(kW)			(MBH)	(kW)		
NGCF/NGEF-076C2	2621	78.70	5.94	0.91	13.25	71.23	7.09	1.19	10.05	67.92	7.35	1.30	9.24
NGCF/NGEF-090C2	2950	95.99	7.25	0.91	13.24	87.28	8.58	1.18	10.17	85.80	8.81	1.23	9.74
NGCF/NGEF-100C2	3556	103.47	8.30	0.96	12.47	93.38	9.87	1.27	9.46	87.72	10.14	1.39	8.65
NGCF/NGEF-120C2	4010	125.66	10.41	0.99	12.07	114.26	12.11	1.27	9.43	112.32	12.40	1.33	9.06
NGCF/NGEF-130C2	4750	137.78	10.63	0.93	12.96	125.16	12.76	1.22	9.81	117.72	13.12	1.34	8.97
NGCF/NGEF-150C2	5100	153.50	12.46	0.97	12.32	139.45	14.03	1.21	9.94	131.16	14.30	1.31	9.17
NGCF/NGEF-175C2	6282	178.20	15.52	1.05	11.48	161.89	17.49	1.30	9.26	159.12	18.39	1.39	8.65
NGCF/NGEF-200C2	6728	202.14	17.36	1.03	11.64	183.64	19.56	1.28	9.39	178.68	20.62	1.38	8.67
NGCF/NGEF-240C2	8000	238.80	19.64	0.99	12.16	216.93	23.22	1.28	9.34	207.00	24.07	1.40	8.60
NGCF/NGEF-270C2	8700	268.77	21.14	0.94	12.72	249.81	26.78	1.29	9.33	239.40	28.02	1.40	8.54
NGCF/NGEF-300C2	9400	294.21	24.23	0.99	12.14	275.58	29.14	1.27	9.46	264.48	30.28	1.37	8.73
NGCF/NGEF-320C2	9987	314.47	25.81	0.98	12.19	294.56	31.32	1.28	9.40	278.64	32.26	1.39	8.64
NGCF/NGEF-340C2	10300	328.83	27.47	1.00	11.97	308.01	32.97	1.28	9.34	291.36	33.91	1.34	8.59

Rating Conditions: Indoor Temperature = 80°F (26.7°C) DB & 67°F (19.4°C) WB.

## OUT STANDING FEATURES

**Indoor Unit:**

- Compact design
- Low profile
- Low sound power level
- For ducted application
- Single speed motors
- Easy maintenance
- Easy installation
- External terminal box

**Outdoor Unit:**

- High efficiency tropical design
- Galvanized heavy gauge panels, oven baked powder coated
- Designed to operate at severe ambient temperature up to 52°C without tripping
- External service valve with gauge ports
- Coil guard protection
- Microprocessor controller
- 240Volt controls

**Options & Accessories**

- Digital thermostat
- Cleanable air filter

## OUT STANDING FEATURES

### Evaporator's Side

- Easy access to the evaporator side with removable panels for maintenance purpose for the fan, motor, belt, pulleys, and expansion device
- Easy access to drain pan for cleaning



### Compressor's Side

- Easy access to the compressor side with removable coil guard or panel for maintenance purpose for the compressor
- Easy access to condenser fans, and motors



### Electrical Panel

- Easy access to the electrical panels with removable panel for microprocessor access and electrical parts

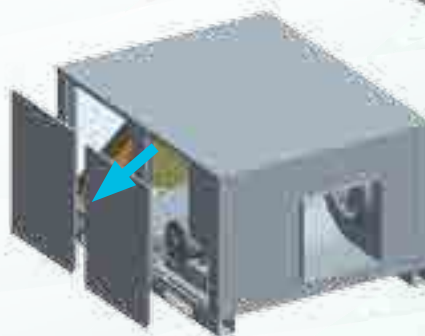

## STANDARD SPECIFICATIONS

### (OUTDOOR UNIT) & (INDOOR UNIT)

#### General

The top discharge condensing units are provided with the latest advanced technology to provide quiet, reliable performance. The straight V-coils adds aesthetical appeal and gives optimum heat transfer efficiency. The access panels & guards provide access to the compressor and to the control box. Removal of top panel gives access to fan motor and coil.

#### Unit Construction

The indoor unit consists of a coil, motor/blower assembly and a drain pan securely mounted on heavy gauge galvanized steel housing.

##### Condenser Fans

Axial type condenser fan are used which precisely match with extra strong fan motor to ensure efficient hot air dissipation.

##### Blower Assembly

The units are provided with centrifugal fans which are statically and dynamically balanced, designed for low sound level operation.

##### Evaporator Coils

The coils are built up of ripple finned seamless copper tubes and mechanically bonded to scientifically designed louvered fins. The assembled coils are factory leak tested under water at a pressure of 350 psig for quality and leak free units.

##### Condenser Fan Motor

The condenser fan motors are a 4/6 poles electric motor which directly drive the condenser fans confirming to BS/IES standards. They are totally enclosed air over type electric motors with built-in thermal protector class F insulation.

##### Condenser Coils

The coils are built up of ripple finned seamless copper tubes and mechanically bonded to scientifically designed louvered fins. The assembled coils are factory leak tested under water at a pressure of 450 [psig] for quality and leak free unit.

##### Unit Casing

The casing sheet metal is fabricated from hot dipped G90, Zinc coating and zero spangle galvanized steel, oven-baked powder coated.

##### Compressor

The compressors are hermetically sealed type. The compressors are equipped with internal motor protector and necessary accessories for safe operation.

##### Evaporator Blower Motor

The evaporator blower motor is Belt Drive the evaporator blower. It is open drip proof type electric motors with built-in thermal protector and permanently lubricated ball bearings class B insulation.

##### Drain Pan

The drain pan is fabricated from galvanized steel. The drain pan is powder coat painted and the outer surface is thermally insulated.

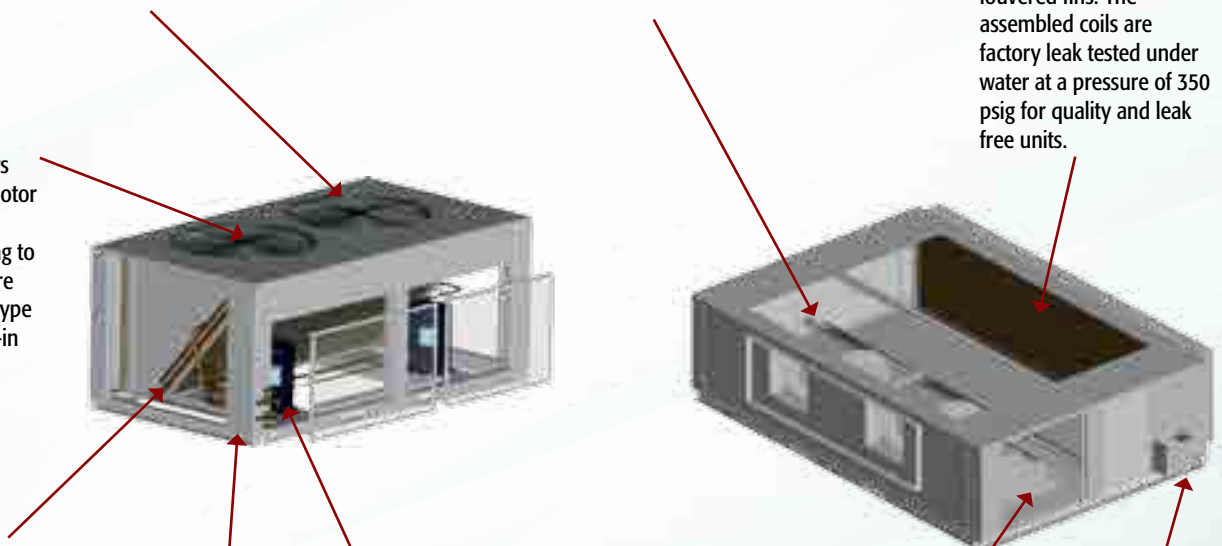

## MICROPROCESSOR BASED CONTROLLER

### Microprocessor Based Controller

The new generation of condensing units is provided with technologically advanced microprocessor based controller, incorporating the following benefits and features:

- Anti-recycle timer
- Compressor lock out function
- Balance loading of compressors
- Compressor lead-lag operation
- Pump down option
- Fault diagnostics
- Indicator lights for high & low pressure safeties

## OPTIONAL SPECIFICATIONS

### Construction & Refrigeration

- Double skin for evaporator side.
- Coil protection materials:
  - a) Polyurethane pre-coat Aluminum fins with copper tubes.
  - b) Tinned copper tubes with copper fins.
- Condenser coil guard.
- Mesh around perimeter of condenser sections.
- Stainless steel drain pan.
- Sight glass
- Vibration isolation for the unit:
  - a) Neoprene rubber pads.
  - b) 1" spring isolator.
- Lockable door for the control panel.
- Pump down solenoid valve (PDS)
- Hot gas bypass valve
- Muffler
- Replaceable filter drier with mechanical shut-off valve

### Electrical

- Electric heaters (open coil type)
- Electric heaters (fin type)
- Compressor circuit breaker
- Mild ambient (fan cycling) control
- Duct sensor
- Adjustable high/low pressure switch
- Anti-ice thermostat
- Volt free contacts
- External overload
- Ultra violet light
- Dirty filter indication
- Fire alarm connection
- Modbus
- Wi-Fi Thermostat

Coolex App



Wi Fi Module



Typical Thermostat



**SELECTION PROCEDURE**

The below example illustrates the selection procedure to assist using this catalog to select the appropriate NGCF/NGEF unit that meets the design requirements.

**Example :**

Design requirements

- Total cooling capacity 195 [MBH]
- Sensible cooling capacity 150 [MBH]
- Design ambient temperature 118.4 [°F]
- Evaporator air flow 7500 [CFM]
- Evaporator entering temperature DB/WB 80/67 [°F/°F]
- External static pressure 0.2 [in.wg]
- Altitude 2000 [ft]
- Power supply 415V / 3Ph / 50Hz

Altitude [ft]	Correction factor
Sea level	1
1000	0.996
2000	0.990
3000	0.984
4000	0.980
5000	0.974
6000	0.965
7000	0.960

Using the correction factor table at the specified altitude, thereby the required capacity will be:

**Corrected capacity** = Required capacity /corr. factor

**Corrected total capacity** = 195 [MBH]/0.99  
= 196.97 MBH

**Corrected sensible capacity** = 150 [MBH]/0.99  
= 151.51 MBH

From the cooling capacity at performance data tables (page 14), the closest selection model to the required capacity is NGCF/NGEF-240 C2 From the performance table:

**Total capacity** = 203.95 [MBH]

**Sensible capacity** = 154.68 [MBH]

**GENERAL DATA**

Outdoor Units		NGCF 076	NGCF 090	NGCF 100	NGCF 120	NGCF 130	NGCF 150
Compressor	Type	Scroll Hermetic					
	Quantity	1	1	1	1	1	2
	Refrigerant	R 410A					
Condenser Fan	Type	Propeller					
	Diameter, mm/Qty	762				610x2	762x2
	Motor Encl./Ins. Class	Totally Enclosed Air Over, Class F					
	Nominal kW (HP)	0.75(1)			1.12 (1.5)	0.56 (0.75)x2	1.1 (1.5)x2
	RPM	900					
Condenser Coil	Type	Enhanced Fins and Tubes					
	Number of Rows	2R/3R					
Refrigerant Charge	kg	7.2	7.7	9.1	9.3	9.2	6.5/5.9
Weight	kg	190	195	206	217	241	540

Indoor Units		NGEF 076	NGEF 090	NGEF 100	NGEF 120	NGEF 130	NGEF 150
Evaporator Blower	Type	Centrifugal Forward Curve DWDI					
	Motor Encl./Ins. Class	Open Drip-Proof, Class B					
	Nominal kW (HP)	0.75 (1)	1.5 (2.0)				2.2 (3)
Evaporator Coil	Type	Enhanced Fins and Tubes					
	Row/FPI	3R/4R					
Air Filter	Min. filter Thickness, mm	25					
	Type	Washable Aluminum Mesh					
Expansion Devices	Type	Thermal Expansion Valve					
Operating Weight	kg	127	160	166	176	181	185

**GENERAL DATA**

Outdoor Units		NGCF 175	NGCF 200	NGCF 240	NGCF 270	NGCF 300	NGCF 320	NGCF 340
Compressor	Type	Scroll Hermetic						
	Quantity	2	2	2	2	2	2	2
	Refrigerant	R 410A						
Condenser Fan	Type	Propeller						
	Diameter, mm/Qty	762/2						800x2
	Motor Encl./Ins. Class	Totally Enclosed Air Over, Class F						
	Nominal kW (HP)	2 x 1.10 (1.5)						2 x 1.25 (1.7)
	RPM	900						
Condenser Coil	Type	Enhanced Fins and Tubes						
	Number of Rows	2R/3R						
Refrigerant Charge	kg	6/5.3	12.3/11.3	12.1/System	12.5/System	13/System	13.2/System	13.5/System
Weight	kg	550	700	718	757	861	920	942

Indoor Units		NGEF 175	NGEF 200	NGEF 240	NGEF 270	NGEF 300	NGEF 320	NGEF 340
Evaporator Blower	Type	Centrifugal Forward Curve DWDI						
	Motor Encl./Ins. Class	Open Drip-Proof, Class B						
	Nominal kW (HP)	3.73(5.0)	3.73(5.0)	3.73(5.0)	3.73(5.0)	5.6(7.5)	5.6(7.5)	5.6(7.5)
Evaporator Coil	Type	Enhanced Fins and Tubes						
	Row/FPI	3R/4R						
Air Filter	Min. filter Thickness, mm	50						
	Type	Washable Aluminum Mesh						
Expansion Devices	Type	Thermal Expansion Valve						
Operating Weight	kg	295	299	387	408	464	508	508

**PERFORMANCE DATA TABLES**

Model	Air On Evaporator			Condenser Ambient Temperature											
	Air Flow		Temp ° F	95° F			115° F			118.4° F			125° F		
	CFM	DB	WB	Capacity Btu/Hr		kw Input	Capacity Btu/Hr		kw Input	Capacity Btu/Hr		kw Input	Capacity Btu/Hr		kw Input
				Total	Sen.		Total	Sen.		Total	Sen.		Total	Sen.	
NGCF/NGEF-076C2	2200	84.2	66.2	75,413	64,101	5.85	67,919	57,731	6.98	64,696	54,991	7.17	61,562	52,327	7.6
		80.0	67.0	76,592	52,197	5.85	69,305	49,141	6.98	66,016	44,880	7.17	62,818	43,057	7.60
		74.0	62.0	67,510	47,255	5.53	61,087	44,488	6.59	57,947	38,272	6.77	55,142	36,709	7.18
		68.0	57.0	58,665	42,220	5.35	53,083	39,749	6.32	50,087	32,044	6.45	47,676	30,742	6.89
	2400	84.2	66.2	76,326	67,930	5.88	69,064	61,467	7.02	65,813	58,573	7.21	62,614	55,727	7.64
		80.0	67.0	77,609	53,230	5.88	70,225	50,113	7.02	66,919	45,842	7.21	63,667	43,981	7.64
		74.0	62.0	68,401	48,235	5.60	61,894	45,411	6.68	58,738	39,048	6.86	55,894	37,467	7.27
		68.0	57.0	59,444	42,931	5.38	53,789	40,418	6.37	50,779	32,850	6.53	48,334	31,045	6.93
	2621	84.2	66.2	77,814	73,923	5.94	70,424	66,903	7.09	67,153	63,795	7.35	63,892	60,697	7.72
		80.0	67.0	78,703	54,223	5.94	71,229	51,064	7.09	67,920	46,876	7.35	64,622	44,886	7.72
		74.0	62.0	69,357	49,072	5.65	62,758	46,199	6.74	59,587	39,883	6.93	56,701	38,262	7.34
		68.0	57.0	60,280	43,854	5.40	54,544	41,286	6.43	51,521	33,752	6.60	49,039	32,053	7.00
NGCF/NGEF-090C2	2600	84.2	66.2	91,550	77,817	7.14	83,226	70,742	8.45	81,796	69,526	8.67	77,699	66,044	9.19
		80.0	67.0	93,418	65,640	7.14	84,924	61,593	8.45	83,465	60,904	8.67	79,285	58,469	9.19
		74.0	62.0	82,341	59,425	6.74	74,854	55,761	7.98	73,568	55,137	8.20	69,884	52,933	8.69
		68.0	57.0	71,553	53,094	6.53	65,047	49,821	7.66	63,928	49,264	7.81	60,727	47,294	8.33
	2800	84.2	66.2	93,094	82,854	7.18	84,629	75,320	8.50	83,175	74,025	8.72	79,010	70,319	9.25
		80.0	67.0	94,659	66,939	7.18	86,052	62,812	8.50	84,573	62,109	8.72	80,338	59,626	9.25
		74.0	62.0	83,428	60,658	6.83	75,842	56,919	8.09	74,539	56,282	8.30	70,806	54,032	8.80
		68.0	57.0	72,504	53,988	6.56	65,911	50,659	7.71	64,778	50,093	7.91	61,533	48,090	8.39
	2950	84.2	66.2	94,909	90,163	7.25	86,295	81,980	8.58	84,831	80,589	8.81	80,589	76,560	9.34
		80.0	67.0	95,993	68,188	7.25	87,281	64,003	8.58	85,800	62,452	8.81	81,510	60,760	9.34
		74.0	62.0	84,594	61,710	6.90	76,902	57,906	8.17	75,580	57,258	8.38	71,795	54,969	8.89
		68.0	57.0	73,522	55,148	6.59	66,837	51,749	7.79	65,688	51,170	7.98	62,398	49,124	8.47
NGCF/NGEF-100C2	2800	84.2	66.2	98,685	83,882	8.17	89,044	75,687	9.72	83,521	70,992	9.98	79,144	67,272	10.58
		80.0	67.0	100,699	66,347	8.17	90,861	62,757	9.72	85,225	65,102	9.98	80,759	62,617	10.58
		74.0	62.0	88,758	60,064	7.72	80,087	56,815	9.18	74,652	55,615	9.43	70,715	53,479	10.00
		68.0	57.0	77,129	53,665	7.47	69,594	50,763	8.81	64,353	46,644	8.99	60,842	44,708	9.59
	3200	84.2	66.2	100,349	89,311	8.22	90,545	80,585	9.78	84,980	75,632	10.04	80,531	71,673	10.64
		80.0	67.0	102,036	67,660	8.22	92,067	63,999	9.78	86,409	66,332	10.04	81,885	63,798	10.64
		74.0	62.0	89,930	61,311	7.82	81,144	57,995	9.30	75,689	56,608	9.56	71,700	54,430	10.13
		68.0	57.0	78,154	54,568	7.51	70,518	51,617	8.87	65,260	47,671	9.10	61,794	45,823	9.66
	3556	84.2	66.2	102,305	97,190	8.30	92,328	87,712	9.87	86,729	82,393	10.14	82,188	78,079	10.75
		80.0	67.0	103,474	68,922	8.30	93,383	65,213	9.87	87,720	67,539	10.14	83,127	64,955	10.75
		74.0	62.0	91,186	62,374	7.90	82,278	59,001	9.39	76,801	57,671	9.65	72,757	55,453	10.23
		68.0	57.0	79,252	55,741	7.55	71,509	52,727	8.96	66,232	48,381	9.19	62,717	46,505	9.75

Note: Capacity in KW= (Btu/hr)\*0.0003. Cooling capacities are gross ratings  
Power Input is Total Power (kW)

**PERFORMANCE DATA TABLES**

Model	Air On Evaporator			Condenser Ambient Temperature											
	Air Flow		Temp ° F	95° F			115° F			118.4° F			125° F		
	CFM	DB	WB	Capacity Btu/Hr		kw Input	Capacity Btu/Hr		kw Input	Capacity Btu/Hr		kw Input	Capacity Btu/Hr		kw Input
				Total	Sen.		Total	Sen.		Total	Sen.		Total	Sen.	
NGCF/NGEF-120C2	3200	84.2	66.2	119,847	101,870	10.24	108,950	92,607	11.91	107,078	91,016	12.20	101,715	86,458	12.93
		80.0	67.0	122,293	81,130	10.25	111,173	75,733	11.92	109,263	74,814	12.21	103,791	71,823	12.94
		74.0	62.0	107,792	73,448	9.69	97,991	68,562	11.27	96,307	67,731	11.54	91,484	65,023	12.23
		68.0	57.0	93,670	65,623	9.38	85,152	61,258	10.81	83,688	60,515	10.99	79,497	58,096	11.73
	3600	84.2	66.2	121,869	108,464	10.30	110,787	98,601	11.98	108,882	96,905	12.27	103,431	92,054	13.09
		80.0	67.0	123,918	82,736	10.31	112,650	77,232	11.99	110,713	76,295	12.28	105,170	73,245	13.02
		74.0	62.0	109,215	74,972	9.81	99,284	69,985	11.41	97,578	69,137	11.69	92,691	66,373	12.39
		68.0	57.0	94,914	66,727	9.42	86,283	62,289	10.88	84,800	61,534	11.13	80,553	59,074	11.81
	4010	84.2	66.2	124,244	118,032	10.40	112,968	107,320	12.10	11,1051	105,499	12.39	105,499	100,224	13.13
		80.0	67.0	125,664	84,279	10.41	114,259	78,696	12.11	112,320	79,591	12.40	106,704	74,637	13.14
		74.0	62.0	110,741	76,272	9.91	100,672	71,199	11.52	98,941	70,336	11.80	93,986	67,524	12.51
		68.0	57.0	96,248	68,162	9.47	87,495	63,628	10.99	85,991	62,857	11.24	81,684	60,343	11.92

NGCF/NGEF-130C2	4000	84.2	66.2	131,402	111,692	10.46	119,346	101,444	12.55	112,084	95,271	12.91	107,241	91,155	13.68
		80.0	67.0	134,084	86,247	10.47	121,782	83,828	12.56	114,371	89,254	12.92	109,430	86,786	13.69
		74.0	62.0	118,184	78,080	9.89	107,342	75,891	11.87	100,182	76,288	12.21	95,951	74,264	12.94
		68.0	57.0	102,701	69,762	9.57	93,277	67,806	11.39	86,361	64,020	11.63	82,822	62,411	12.41
	4300	84.2	66.2	133,619	118,921	10.52	121,359	108,009	12.62	114,043	101,498	12.98	109,106	97,104	13.76
		80.0	67.0	135,865	87,954	10.53	123,399	85,487	12.63	115,960	90,905	12.99	110,940	88,372	13.77
		74.0	62.0	119,745	79,700	10.02	108,759	77,466	12.02	101,574	77,621	12.37	97,273	75,542	13.11
		68.0	57.0	104,065	70,936	9.62	94,517	68,948	11.46	87,579	65,400	11.78	83,978	63,739	12.50
	4750	84.2	66.2	136,223	129,411	10.63	123,748	117,561	12.75	116,390	110,571	13.11	111,348	105,780	13.90
		80.0	67.0	137,779	89,594	10.63	125,162	87,109	12.76	117,720	92,525	13.12	112,620	89,925	13.91
		74.0	62.0	121,418	81,082	10.11	110,278	78,810	12.14	103,067	79,046	12.48	98,691	76,898	13.23
		68.0	57.0	105,527	72,461	9.67	95,845	70,430	11.57	88,883	66,350	11.89	85,218	64,640	12.62

NGCF/NGEF-150C2	4200	84.2	66.2	146,391	124,433	12.25	132,970	113,025	13.80	124,880	106,148	14.07	119,859	101,880	14.91
		80.0	67.0	149,379	98,781	12.26	135,684	90,935	13.81	127,429	94,937	14.08	122,305	91,879	14.92
		74.0	62.0	131,666	89,427	11.59	119,596	82,325	13.05	111,620	81,126	13.30	107,287	78,622	14.10
		68.0	57.0	114,416	79,901	11.22	103,926	73,555	12.52	96,221	68,062	12.67	92,659	66,079	13.53
	4700	84.2	66.2	148,860	132,486	12.33	135,213	120,339	13.89	127,063	113,086	14.15	121,938	108,525	14.99
		80.0	67.0	151,363	100,736	12.34	137,486	92,735	13.90	129,199	96,710	14.16	123,988	93,582	15.01
		74.0	62.0	133,404	91,283	11.74	121,174	84,034	13.22	113,171	82,557	13.48	108,760	79,994	14.29
		68.0	57.0	115,935	81,245	11.27	105,306	74,793	12.61	97,578	69,544	12.83	93,948	67,505	13.62
	5100	84.2	66.2	151,762	144,174	12.45	137,875	130,981	14.02	129,678	123,194	14.29	124,438	118,216	15.14
		80.0	67.0	153,496	102,615	12.46	139,450	94,494	14.03	131,160	98,450	14.30	125,860	95,250	15.16
		74.0	62.0	135,268	92,866	11.85	122,867	85,492	13.35	114,834	84,089	13.61	110,340	81,450	14.42
		68.0	57.0	117,565	82,991	11.33	106,786	76,401	12.73	99,031	70,564	12.96	95,329	68,471	13.75

Note: Capacity in KW= (Btu/hr)\*0.0003. Cooling capacities are gross ratings  
Power Input is Total Power (kW)

**PERFORMANCE DATA TABLES**

Model	Air On Evaporator			Condenser Ambient Temperature											
	Air Flow		Temp ° F	95° F			115° F			118.4° F			125° F		
	CFM	DB	WB	Capacity Btu/Hr		kw Input	Capacity Btu/Hr		kw Input	Capacity Btu/Hr		kw Input	Capacity Btu/Hr		kw Input
				Total	Sen.		Total	Sen.		Total	Sen.		Total	Sen.	
NGCF/NGEF-175C2	5100	84.2	66.2	169,951	144,458	15.25	154,370	131,214	17.19	151,693	128,939	17.50	144,096	122,482	18.56
		80.0	67.0	173,419	122,132	15.28	157,520	112,431	17.22	154,789	110,780	17.54	147,037	106,351	18.60
		74.0	62.0	152,855	110,567	14.44	138,843	101,786	16.27	136,435	100,292	16.58	129,602	96,282	17.57
		68.0	57.0	132,829	98,788	14.05	120,651	90,943	15.60	118,558	89,608	15.79	112,621	86,026	16.86
	5700	84.2	66.2	172,818	153,808	15.34	156,973	139,706	17.29	154,290	137,318	17.61	146,528	130,410	18.67
		80.0	67.0	175,723	124,549	15.37	159,612	114,657	17.32	156,844	112,973	17.65	148,991	108,457	18.71
		74.0	62.0	154,874	112,861	14.63	140,675	103,899	16.48	138,235	102,374	16.79	131,312	98,281	17.80
		68.0	57.0	134,593	100,451	13.98	122,254	92,474	15.71	120,133	91,116	15.99	114,116	87,473	16.97
	6282	84.2	66.2	176,185	167,376	15.49	160,053	152,051	17.46	157,322	149,456	18.35	149,456	141,983	18.85
		80.0	67.0	178,198	126,873	15.52	161,892	116,831	17.49	159,120	114,795	18.39	151,164	110,519	18.89
		74.0	62.0	157,037	114,819	14.77	142,640	105,701	16.64	140,167	104,150	16.96	133,147	99,985	17.97
		68.0	57.0	136,485	102,610	14.11	123,971	94,462	15.86	121,821	93,075	16.15	115,719	89,353	17.13

NGCF/NGEF-200C2	6000	84.2	66.2	192,786	163,868	17.06	175,111	148,845	19.21	172,075	146,264	19.58	163,458	138,939	20.76
		80.0	67.0	196,720	142,871	17.09	178,685	131,523	19.25	175,587	129,592	19.62	166,794	124,410	20.80
		74.0	62.0	173,394	129,343	16.15	157,498	119,070	18.19	154,767	117,322	18.54	147,016	112,631	19.65
		68.0	57.0	150,677	115,563	15.71	136,862	106,386	17.45	134,487	104,824	17.66	127,753	100,634	18.85
	6300	84.2	66.2	196,037	174,473	17.16	178,064	158,477	19.33	174,976	155,729	19.70	166,216	147,932	20.88
		80.0	67.0	199,333	145,698	17.19	181,058	134,126	19.37	177,918	130,157	19.74	169,010	126,874	20.92
		74.0	62.0	175,683	132,026	16.36	159,577	121,542	18.43	156,809	119,758	18.78	148,956	114,970	19.91
		68.0	57.0	152,678	117,508	15.63	138,680	108,176	17.57	136,275	106,588	17.89	129,449	102,326	18.98
	6728	84.2	66.2	199,858	189,865	17.33	181,570	172,492	19.52	176,661	167,828	20.58	169,538	161,061	21.09
		80.0	67.0	202,142	148,417	17.36	183,645	136,670	19.56	178,680	131,315	20.62	171,475	129,286	21.13
		74.0	62.0	178,138	134,316	16.52	161,806	123,650	18.61	159,000	121,835	18.96	151,037	116,964	20.10
		68.0	57.0	154,823	120,034	15.79	140,628	110,502	17.74	138,189	108,880	18.06	131,268	104,526	19.16

NGCF/NGEF-240C2	7000	84.2	66.2	184,201	156,571	19.29	168,567	143,282	22.81	163,174	138,698	23.41	157,571	133,936	24.82
		80.0	67.0	232,391	165,038	19.33	211,070	143,148	22.86	201,196	151,919	23.46	187,360	128,055	24.87
		74.0	62.0	204,834	149,410	18.27	186,042	129,595	21.60	176,604	130,132	22.17	163,998	109,067	23.50
		68.0	57.0	177,998	133,493	17.68	161,666	115,789	20.72	152,649	109,508	21.12	141,244	91,155	22.54
	7500	84.2	66.2	187,308	166,704	19.41	171,409	152,554	22.95	165,961	147,705	23.55	160,229	142,604	24.97
		80.0	67.0	235,477	168,304	19.45	213,872	145,981	23.00	203,950	154,679	23.60	189,977	130,705	25.02
		74.0	62.0	207,539	152,510	18.51	188,498	132,285	21.88	179,016	132,358	22.46	166,290	111,205	23.81
		68.0	57.0	180,362	135,739	17.77	163,814	117,738	20.86	154,760	111,824	21.39	143,248	93,365	22.70
	8000	84.2	66.2	190,958	181,410	19.60	174,784	166,045	23.17	169,305	160,840	24.02	163,433	155,261	25.21
		80.0	67.0	238,795	171,444	19.64	216,928	148,750	23.22	207,000	157,386	24.07	192,890	133,300	25.26
		74.0	62.0	210,438	155,156	18.68	191,131	134,579	22.09	181,604	134,744	22.67	168,748	113,474	24.03
		68.0	57.0	182,897	138,657	17.85	166,115	120,269	21.06	157,021	113,408	21.59	145,396	94,874	22.91

Note: Capacity in KW= (Btu/hr)\*0.0003. Cooling capacities are gross ratings  
Power Input is Total Power (kW)

**PERFORMANCE DATA TABLES**

Model	Air On Evaporator			Condenser Ambient Temperature											
	Air Flow		Temp ° F	95° F			115° F			118.4° F			125° F		
	CFM	DB	WB	Capacity Btu/Hr		kw Input	Capacity Btu/Hr		kw Input	Capacity Btu/Hr		kw Input	Capacity Btu/Hr		kw Input
				Total	Sen.		Total	Sen.		Total	Sen.		Total	Sen.	
NGCF/NGEF-270C2	8000	84.2	66.2	256,335	217,884	20.73	238,200	202,470	26.26	228,034	193,829	27.20	217,271	184,680	28.83
		80.0	67.0	261,566	170,752	20.81	243,061	155,997	26.37	232,688	159,220	27.31	221,705	153,083	28.95
		74.0	62.0	230,550	154,583	19.66	214,240	141,227	24.91	204,246	136,215	25.81	194,687	131,015	27.36
		68.0	57.0	200,345	138,115	19.03	186,169	126,182	23.90	181,542	120,960	24.58	168,371	110,151	26.24
	8300	84.2	66.2	260,658	231,986	20.85	242,157	215,520	26.41	231,973	206,456	27.36	221,016	196,705	29.00
		80.0	67.0	265,040	174,131	20.93	246,288	159,085	26.52	235,873	162,257	27.47	224,732	156,000	29.12
		74.0	62.0	233,594	157,791	19.92	217,068	144,159	25.24	207,036	138,665	26.14	197,336	133,363	27.71
		68.0	57.0	203,005	140,439	19.13	188,643	128,306	24.06	178,983	117,013	24.90	170,689	112,598	26.42
	8700	84.2	66.2	265,738	252,451	21.06	246,985	234,636	26.67	236,695	224,861	27.91	225,523	214,247	29.28
		80.0	67.0	268,774	177,379	21.14	249,807	162,102	26.78	239,400	165,238	28.02	228,100	158,858	29.40
		74.0	62.0	236,857	160,527	20.11	220,100	146,659	25.48	210,029	141,297	26.40	200,179	135,866	27.98
		68.0	57.0	205,858	143,458	19.22	191,293	131,064	24.29	181,598	118,761	25.13	173,173	114,252	26.67
NGCF/NGEF-300C2	8200	84.2	66.2	280,590	238,501	23.75	262,776	223,360	28.58	251,924	214,135	29.39	237,959	202,265	31.16
		80.0	67.0	286,316	204,178	23.85	268,139	186,085	28.69	257,065	164,780	29.51	242,815	157,463	31.29
		74.0	62.0	252,365	184,844	22.54	236,345	168,466	27.11	225,644	140,415	27.89	212,967	134,078	29.56
		68.0	57.0	219,302	165,152	21.82	205,378	150,519	26.01	195,037	117,468	26.57	183,894	112,056	28.36
	8700	84.2	66.2	285,323	253,938	23.89	267,207	237,814	28.74	256,275	228,084	29.57	242,090	215,460	31.34
		80.0	67.0	290,120	208,219	23.99	271,699	189,767	28.86	260,583	168,402	29.69	246,160	160,941	31.47
		74.0	62.0	255,698	188,680	22.83	239,464	171,963	27.47	228,726	143,338	28.26	215,894	136,880	29.95
		68.0	57.0	222,215	167,931	21.93	208,106	153,052	26.19	197,734	120,503	26.91	186,455	114,965	28.55
	9400	84.2	66.2	290,883	276,339	24.13	272,468	258,844	29.02	261,492	248,418	30.16	247,057	234,704	31.65
		80.0	67.0	294,207	212,103	24.23	275,581	193,366	29.14	264,480	171,955	30.28	249,880	164,348	31.78
		74.0	62.0	259,270	191,952	23.05	242,809	174,946	27.73	232,032	146,484	28.53	219,035	139,873	30.24
		68.0	57.0	225,337	171,541	22.03	211,030	156,343	26.44	200,623	122,591	27.16	189,199	116,946	28.83
NGCF/NGEF-320C2	9000	84.2	66.2	299,918	254,930	25.31	280,877	238,745	30.72	265,300	225,505	31.63	252,338	214,488	33.53
		80.0	67.0	306,039	217,124	25.41	286,609	199,540	30.84	270,714	175,375	31.76	257,488	167,516	33.66
		74.0	62.0	269,749	196,564	24.01	252,625	180,648	29.14	237,129	149,158	30.01	225,584	142,472	31.81
		68.0	57.0	234,409	175,624	23.24	219,525	161,403	27.95	204,413	124,471	28.59	194,508	118,708	30.52
	9400	84.2	66.2	304,977	271,429	25.46	285,613	254,196	30.90	269,937	240,244	31.82	256,747	228,504	33.72
		80.0	67.0	310,104	221,421	25.56	290,415	203,489	31.02	274,475	179,265	31.95	261,063	171,252	33.86
		74.0	62.0	273,311	200,643	24.32	255,959	184,397	29.52	240,423	152,296	30.40	228,713	145,483	32.23
		68.0	57.0	237,522	178,579	23.35	222,441	164,120	28.14	207,296	127,717	28.95	197,245	122,011	30.72
	9987	84.2	66.2	310,920	295,374	25.71	291,236	276,674	31.19	275,492	261,718	32.13	262,046	248,944	34.06
		80.0	67.0	314,473	225,552	25.81	294,564	207,349	31.32	278,640	183,081	32.26	265,040	174,911	34.20
		74.0	62.0	277,130	204,123	24.56	259,535	187,596	29.80	243,957	155,671	30.70	232,070	148,693	32.54
		68.0	57.0	240,859	182,418	23.46	225,566	167,648	28.41	210,384	129,965	29.23	200,179	124,143	31.02

Note: Capacity in KW= (Btu/hr)\*0.0003. Cooling capacities are gross ratings  
Power Input is Total Power (kW)

**PERFORMANCE DATA TABLES**

Model	Air On Evaporator			Condenser Ambient Temperature												
	Air Flow		Temp ° F	95° F				115° F			118.4° F			125° F		
	CFM	DB	WB	Capacity Btu/Hr		kw Input	Capacity Btu/Hr		kw Input	Capacity Btu/Hr		kw Input	Capacity Btu/Hr		kw Input	
				Total	Sen.		Total	Sen.		Total	Sen.		Total	Sen.		
<b>NGCF/NGEF-340C2</b>	9400	84.2	66.2	313,609	266,567	26.93	293,699	249,644	32.33	277,411	235,799	33.25	263,879	224,297	35.25	
		80.0	67.0	320,009	224,318	27.04	299,693	213,065	32.46	283,072	180,138	33.38	269,264	171,696	35.39	
		74.0	62.0	282,063	203,077	25.55	264,157	192,891	30.68	247,954	152,998	31.55	235,903	145,815	33.44	
		68.0	57.0	245,109	181,443	24.73	229,546	172,342	29.43	213,745	127,477	30.05	203,409	121,485	32.08	
	9800	84.2	66.2	318,899	283,820	27.09	298,651	265,800	32.53	282,309	251,255	33.45	268,488	238,955	35.46	
		80.0	67.0	324,260	228,757	27.20	303,672	217,282	32.66	287,005	184,317	33.58	273,002	175,710	35.60	
		74.0	62.0	285,787	207,291	25.89	267,643	196,895	31.08	251,398	156,369	31.96	239,175	149,052	33.88	
		68.0	57.0	248,364	184,496	24.86	232,596	175,243	29.63	216,760	130,963	30.43	206,271	124,834	32.30	
	10300	84.2	66.2	32,5114	308,858	27.36	304,530	289,304	32.84	288,068	273,665	33.77	274,029	260,327	35.80	
		80.0	67.0	328,829	233,025	27.47	308,010	221,402	32.97	291,360	188,418	33.91	277,160	179,640	35.94	
		74.0	62.0	289,780	210,886	26.13	271,383	200,311	31.37	255,093	160,000	32.27	242,685	152,504	34.20	
		68.0	57.0	251,854	188,462	24.97	235,863	179,011	29.91	219,989	133,383	30.73	209,338	127,125	32.61	

Note: Capacity in KW= (Btu/hr)\*0.0003. Cooling capacities are gross ratings  
Power Input is Total Power (kW)

**UNIT ELECTRICAL DATA**

Outdoor Units		NGCF-076	NGCF-090	NGCF-100	NGCF-120	NGCF-130	NGCF-150
Unit Power Supply	Volt	415					
	Phase	3					
	Hz	50					
Compressor	V - Ph - Hz	415-3-50					
	RLA	13.6	14.5	16.4	17.9	20.8	13.6 each
	LRA	100	100	128	139	144	100 each
Condenser Fan Motor	V - Ph - Hz	415-3-50					
	kW (hp)	0.75 (1)	0.75 (1)	0.75 (1)	1.12 (1.5)	2x0.56 (3/4)	2x1.12 (1.5)
	FLA	2.43	2.43	2.43	3	1.6 each	3 each
Unit Ampacity, Ampere		19.4	20.6	22.9	25.4	29.2	36.6
Max. Fuse Size, Ampere		30	35	35	40	50	50
Minimum Wire Size, mm <sup>2</sup>		4	6	6	6	10	16

Indoor Units		NGEF-076	NGEF-090	NGEF-100	NGEF-120	NGEF-130	NGEF-150
Unit Power Supply	Volt	415					
	Phase	3					
	Hz	50					
Blower Motor	V - Ph - Hz	415-3-50					
	kW (hp)	0.75 (1)	1.5 (2)	1.5 (2)	1.5 (2)	1.5 (2)	2.24 (3)
	FLA	2.4	2.4	4.3	4.3	4.3	4.6
Max. Fuse Size, Ampere		5	5	10	10	10	10
Minimum Wire Size, mm <sup>2</sup>		2.5	2.5	2.5	2.5	2.5	2.5

Outdoor Units		NGCF-175	NGCF-200	NGCF-240	NGCF-270	NGCF-300	NGCF-320	NGCF-340
Unit Power Supply	Volt	415						
	Phase	3						
	Hz	50						
Compressor	V - Ph - Hz	415-3-50						
	RLA	14.5/13.6	14.5 each	17.9 each	20.8/17.9	20.8 each	24.3 each	27.9/24.3
	LRA	101/100	100 each	139 each	144/139	144 each	140 each	173/140
Condenser Fan Motor	V - Ph - Hz	415-3-50						
	kW (hp)	2x 1.12(1.5)	2x 1.12(1.5)	2x 1.10(1.5)	2x 1.10(1.5)	2x 1.10(1.5)	2x 1.10(1.5)	2x 1.5(2)
	FLA	3 each	3 each	3 each	3 each	3 each	3 each	3.8 each
Unit Ampacity, Ampere		37.7	38.6	46.3	49.9	52.8	60.7	66.8
Max. Fuse Size, Ampere		50	50	60	70	70	80	90
Minimum Wire Size, mm <sup>2</sup>		16	16	16	16	25	25	30

Indoor Units		NGEF-175	NGEF-200	NGEF-240	NGEF-270	NGEF-300	NGEF-320	NGEF-340
Unit Power Supply	Volt	415						
	Phase	3						
	Hz	50						
Blower Motor	V - Ph - Hz	415-3-50						
	kW (hp)	3.7(5.0)	3.7(5.0)	3.7(5.0)	3.7(5.0)	5.6(7.5)	5.6(7.5)	5.6(7.5)
	FLA	7.2	7.2	7.2	7.2	10.7	10.7	10.7
Max. Fuse Size, Ampere		15	15	16	16	20	20	20
Minimum Wire Size, mm <sup>2</sup>		2.5	2.5	2.5	2.5	2.5	2.5	2.5

**LEGEND:**

- FLA - Full Load Amps
- RLA - Rated Load Amps
- LRA - Locked Rotor Amps

FAN PERFORMANCE

Model	CFM	External Static Pressure [in.wg]																			
		0.10		0.20		0.30		0.40		0.50		0.60		0.70		0.80		0.90		1.00	
		RPM	BHP	RPM	BHP	RPM	BHP	RPM	BHP	RPM	BHP	RPM	BHP	RPM	BHP	RPM	BHP	RPM	BHP	RPM	BHP
NGEC-076	2200	770	0.55	810	0.60	848	0.64	886	0.70	923	0.75	-	-	-	-	-	-	-	-	-	-
	2400	776	0.63	814	0.67	851	0.72	887	0.78	922	0.83	-	-	-	-	-	-	-	-	-	-
	2621	784	0.71	821	0.76	856	0.82	891	0.87	-	-	-	-	-	-	-	-	-	-	-	-
NGEC-090	2600	632	0.64	668	0.70	703	0.77	736	0.85	-	-	-	-	-	-	-	-	-	-	-	-
	2800	632	0.69	666	0.76	700	0.84	732	0.91	764	0.99	795	1.06	-	-	-	-	-	-	-	-
	2950	632	0.74	665	0.81	698	0.88	730	0.96	762	1.04	792	1.12	822	1.20	851	1.28	-	-	-	-
NGEC-100	2800	632	0.69	666	0.76	700	0.84	732	0.91	764	0.99	795	1.06	-	-	-	-	-	-	-	-
	3200	634	0.82	666	0.90	698	0.97	729	1.05	759	1.13	789	1.22	818	1.30	846	1.39	874	1.47	901	1.56
	3556	641	0.98	672	1.06	702	1.14	731	1.22	760	1.31	788	1.39	815	1.48	842	1.57	869	1.66	895	1.76

Model	CFM	External Static Pressure [in.wg]																			
		0.30		0.40		0.60		0.80		1.00		1.20		1.40		1.60		1.80		2.00	
		RPM	BHP	RPM	BHP	RPM	BHP	RPM	BHP	RPM	BHP	RPM	BHP	RPM	BHP	RPM	BHP	RPM	BHP	RPM	BHP
NGEF-120	3200	708	0.84	738	1.00	798	1.15	857	1.34	-	-	-	-	-	-	-	-	-	-	-	-
	3600	713	1.06	742	1.14	798	1.30	853	1.47	906	1.66	957	1.86	1008	2.06	-	-	-	-	-	-
	4010	721	1.23	749	1.34	803	1.49	855	1.68	905	1.86	953	2.05	1001	2.27	1048	2.48	1094	2.71	1139	2.94
NGEF-130	4000	721	1.23	749	1.34	803	1.49	855	1.68	905	1.86	953	2.05	1001	2.27	1048	2.48	1094	2.71	1139	2.94
	4300	728	1.39	756	1.47	808	1.65	859	1.84	907	2.02	954	2.23	1000	2.44	1045	2.65	1089	2.87	1132	3.10
	4750	740	1.61	766	1.70	818	1.89	866	2.09	913	2.29	958	2.49	1002	2.71	1045	2.92	1087	3.15	1128	3.38
NGEF-150	4200	726	1.34	753	1.42	806	1.60	857	1.78	906	1.97	954	2.17	1000	2.37	1045	2.59	1090	2.82	1134	3.04
	4700	737	1.55	764	1.65	815	1.84	864	2.02	911	2.23	957	2.43	1001	2.63	1045	2.86	1087	3.07	1129	3.31
	5100	752	1.85	778	1.96	828	2.14	875	2.36	921	2.56	965	2.77	1007	2.99	1049	3.22	1089	3.44	1129	3.69
NGEF-175	5100	859	1.80	892	1.90	954	2.10	1014	2.32	1071	2.52	1126	2.74	1179	2.94	1231	3.16	1281	3.38	1329	3.60
	5700	878	2.20	909	2.30	968	2.54	1025	2.78	1080	3.00	1133	3.24	1185	3.46	1235	3.70	1283	3.94	1330	4.18
	6282	902	2.66	930	2.78	986	3.04	1041	3.28	1093	3.54	1145	3.80	1194	4.06	1242	4.32	1289	4.58	1335	4.82
NGEF-200	6000	889	2.42	919	2.54	977	2.78	1032	3.02	1086	3.26	1139	3.50	1189	3.76	1238	4.00	1286	4.24	1332	4.50
	6300	902	2.66	930	2.78	986	3.04	1041	3.28	1093	3.54	1145	3.80	1194	4.06	1242	4.32	1289	4.58	1335	4.82
	6728	921	3.02	949	3.16	1002	3.42	1054	3.70	1105	3.98	1155	4.24	1203	4.52	1250	4.80	1296	5.06	1341	5.34
NGEF-240	7000	884	2.66	915	2.82	975	3.10	1031	3.38	1085	3.66	1137	3.96	1188	4.24	1237	4.54	1286	4.84	1333	5.16
	7500	898	3.04	929	3.18	987	3.50	1042	3.80	1095	4.10	1146	4.40	1195	4.76	1243	5.02	1290	5.34	1336	5.66
	8000	914	3.44	943	3.60	1001	3.92	1055	4.24	1107	4.58	1156	4.90	1204	5.22	1251	5.56	1297	5.88	1342	6.22
NGEF-270	8000	709	2.66	737	2.84	791	3.20	843	3.58	893	3.96	942	4.36	989	4.78	1035	5.20	1080	5.62	1124	6.08
	8300	712	2.82	740	3.00	793	3.16	844	3.76	893	4.14	941	4.56	983	4.98	1033	5.40	1078	5.84	1121	6.30
	8700	742	3.12	769	3.30	795	3.48	845	3.88	894	4.28	941	4.68	987	5.12	1032	5.54	1076	6.00	1119	6.44

See Note on pg. 18

## FAN PERFORMANCE

Model	CFM	External Static Pressure [in.wg]																					
		0.40		0.50		0.60		0.80		1.00		1.20		1.40		1.60		1.80		2.00			
		RPM	BHP	RPM	BHP	RPM	BHP	RPM	BHP	RPM	BHP	RPM	BHP	RPM	BHP	RPM	BHP	RPM	BHP	RPM	BHP		
NGEF-300	8200	739	2.94	766	3.12	792	3.32	843	3.70	893	4.08	941	4.50	988	4.90	1034	5.34	1078	5.78	1122	6.22		
	8700	742	3.12	769	3.30	795	3.48	845	3.88	894	4.28	941	4.68	987	5.12	1032	5.54	1076	6.00	1119	6.44		
	9400	753	3.68	779	3.88	804	4.08	852	4.48	899	4.90	944	5.34	988	5.78	1031	6.24	1073	6.70	1114	7.18		
NGEF-320	9000	748	3.42	774	3.62	799	3.80	849	4.20	896	4.62	942	5.04	987	5.46	1031	5.92	1074	6.38	1116	6.84		
	9400	753	3.68	779	3.88	804	4.08	852	4.48	899	4.90	944	5.34	988	5.78	1031	6.24	1073	6.70	1114	7.18		
	9987	762	4.10	787	4.32	812	4.46	859	4.94	904	5.38	948	5.82	991	6.28	1033	6.74	1074	7.22	1114	7.72		
NGEF-340	9400	753	3.68	779	3.88	804	4.08	852	4.48	899	4.90	944	5.34	988	5.78	1031	6.24	1073	6.70	1114	7.18		
	9800	759	3.96	785	4.16	809	4.36	857	4.78	902	5.22	947	5.66	990	6.10	1032	6.56	1073	7.04	1114	7.52		
	10300	766	4.18	790	4.46	814	4.64	861	5.10	906	5.54	950	6.00	992	6.46	1034	6.92	1074	7.40	1114	7.90		

## LEGEND:

RPM : Fan Speed in revolution per minute  
 BHP : Fan absorbed power

## Note:

1. Internal Static pressure is based on pressure drops through evaporator coil, fan casing and 2" washable filters.
2. Blue shaded area indicates the operating range of a standard motor and drive combination.
3. Green shaded area indicates the operating range of a standard motor with non standard drive combination.
4. Gray shaded area indicates operating range using non standard motor and drive combination.
5. To determine the power of motor to be installed, just multiply the value of the absorbed power indicated above by 1.2.

# UNIT DIMENSIONS

## Indoor Unit

**NGEF-076**

ALL DIMENSIONS ARE IN MM

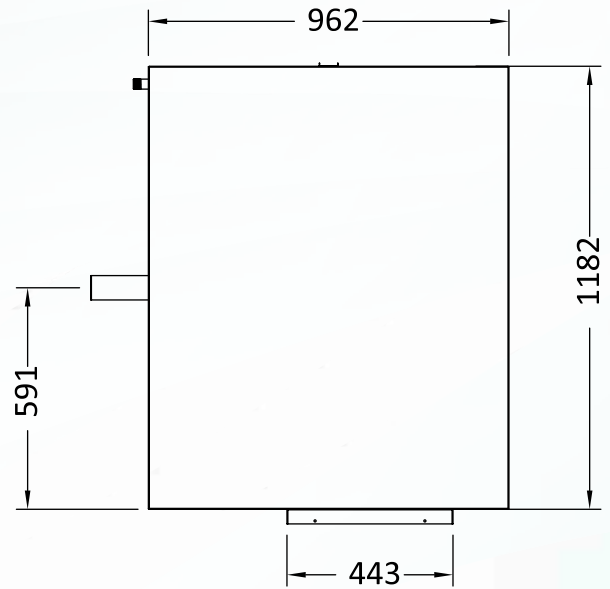

TOP VIEW

Ø22.2 SUCTION CONN.  
Ø12.7 LIQUID CONN.  
Ø27 DRAIN CONN.

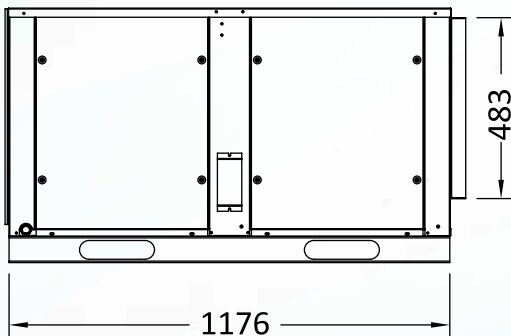

SIDE VIEW

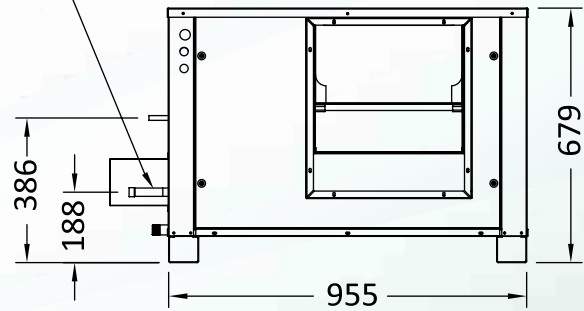

FRONT VIEW

# UNIT DIMENSIONS

## Outdoor Unit

**NGCF-076**

ALL DIMENSIONS ARE IN MM

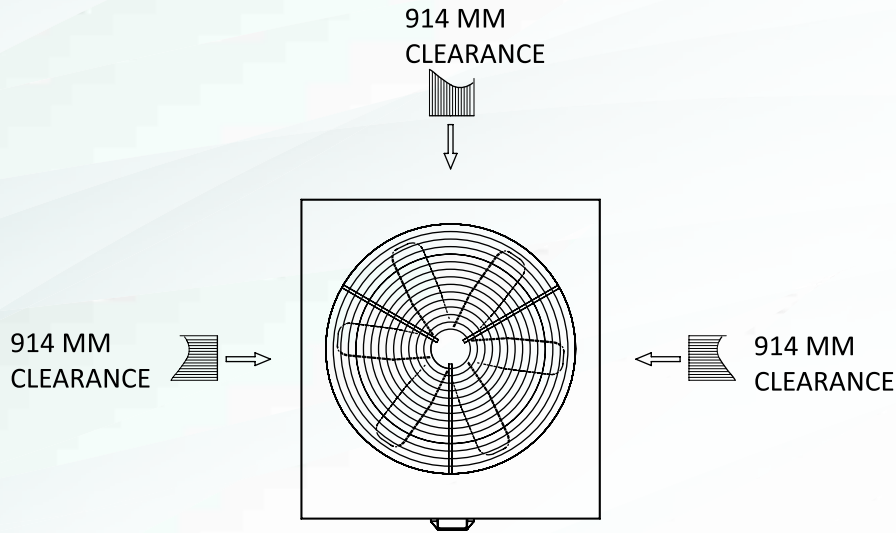

TOP VIEW

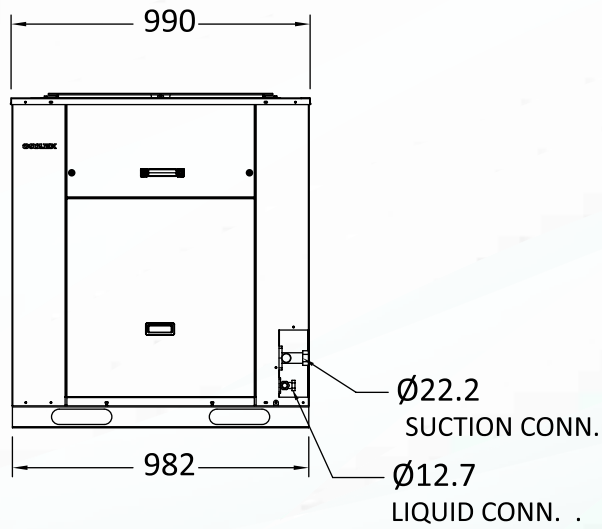

SIDE VIEW

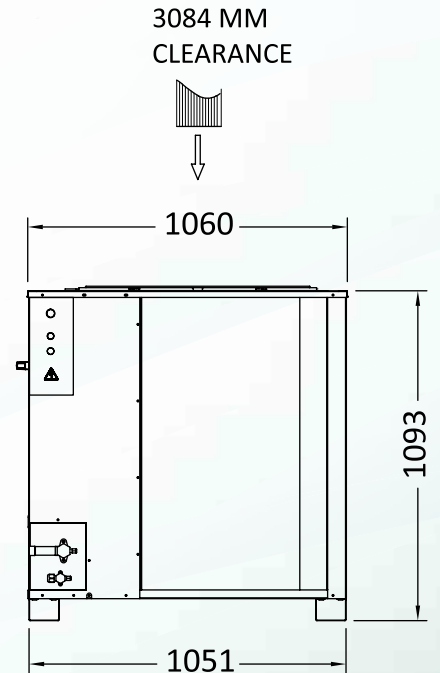

FRONT VIEW

**UNIT DIMENSIONS**

**Indoor Unit**

**NGEF-090**

ALL DIMENSIONS ARE IN MM

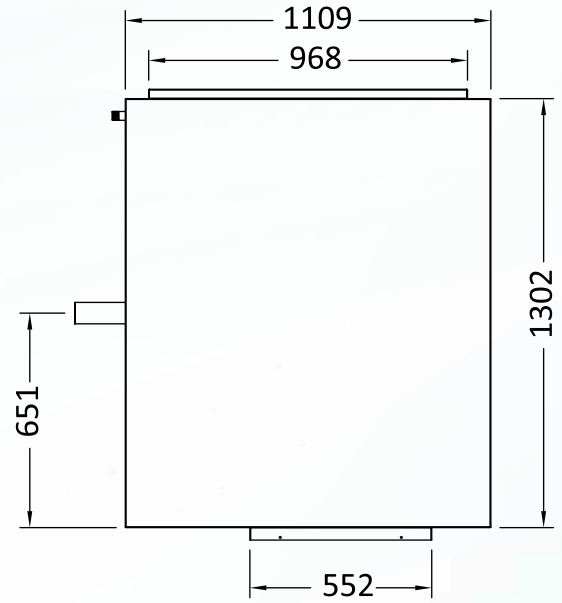

**TOP VIEW**

Ø28.6 SUCTION CONN.  
 Ø15.9 LIQUID CONN.  
 Ø27.0 DRAIN CONN.

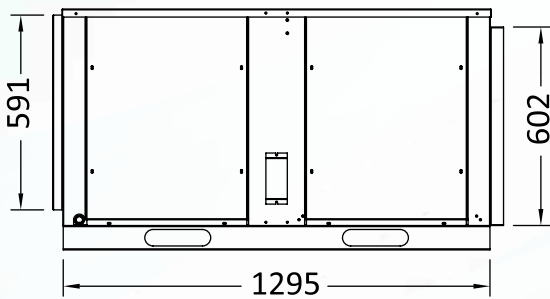

**SIDE VIEW**

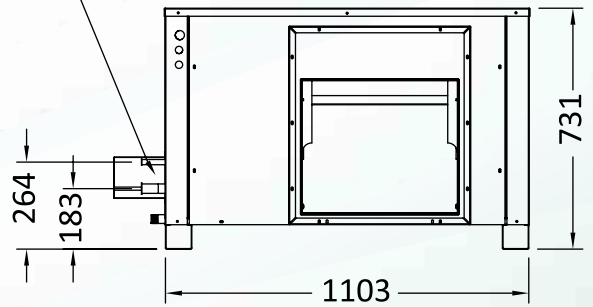

**FRONT VIEW**

**UNIT DIMENSIONS**

**Outdoor Unit**

**NGCF-090**

ALL DIMENSIONS ARE IN MM

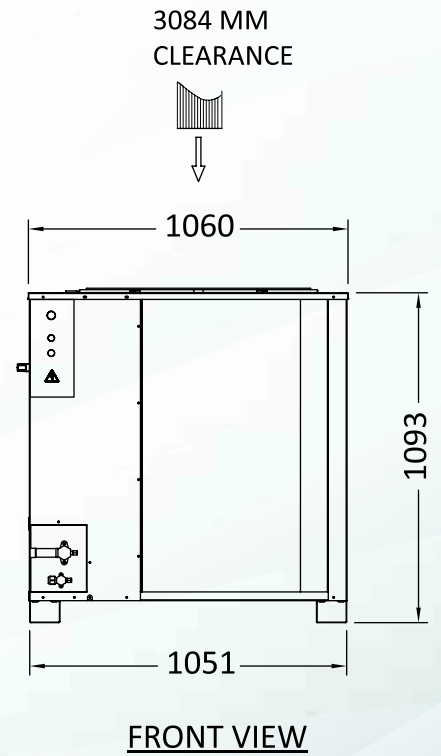
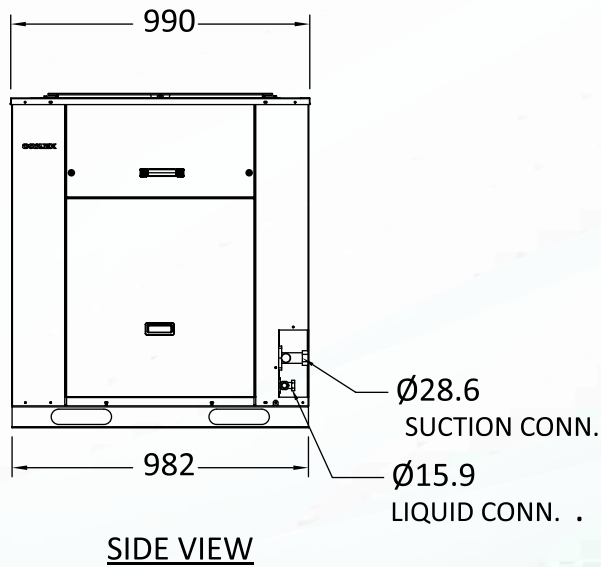
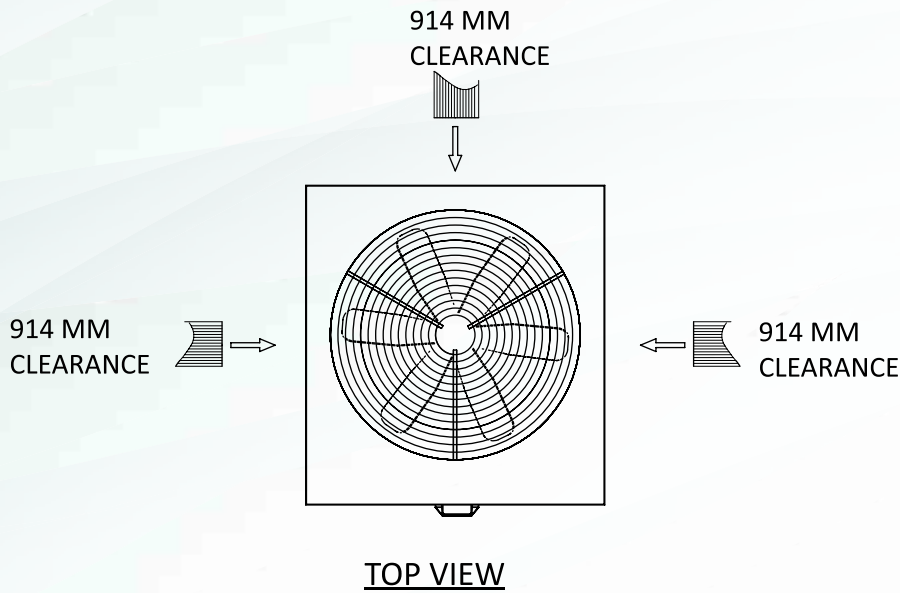

**UNIT DIMENSIONS**

**Indoor Unit**

**NGEF-100/120**

ALL DIMENSIONS ARE IN MM

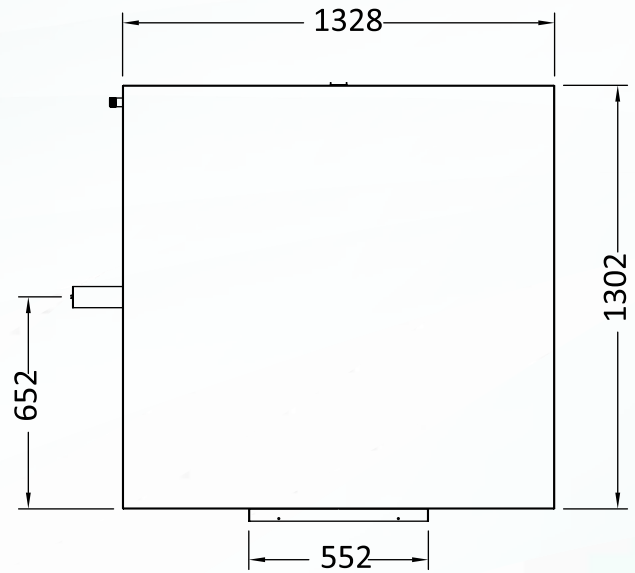

**TOP VIEW**

Ø28.6 SUCTION CONN.  
 Ø15.9 LIQUID CONN.  
 Ø27.0 DRAIN CONN.

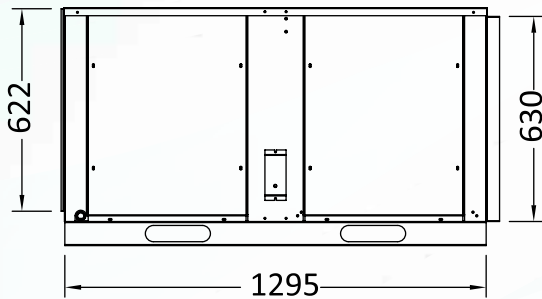

**SIDE VIEW**

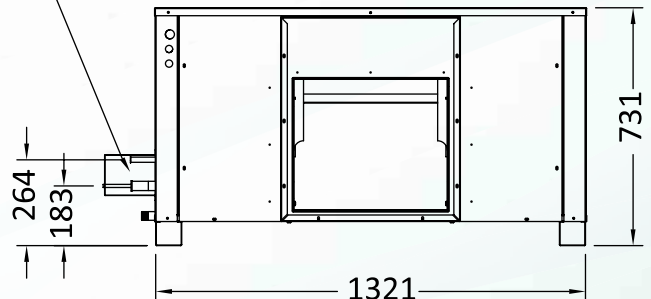

**FRONT VIEW**

**UNIT DIMENSIONS**

**Outdoor Unit**

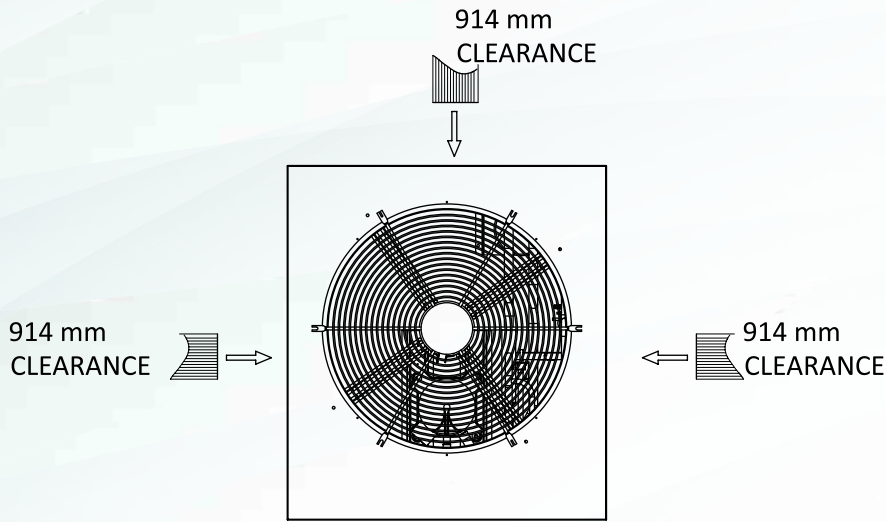

**TOP VIEW**

**NGCF-100/120**

ALL DIMENSIONS ARE IN MM

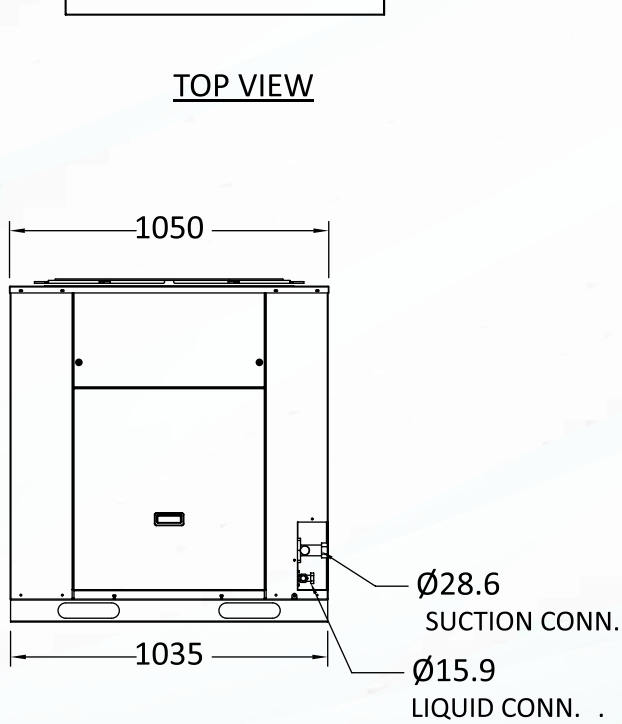

**SIDE VIEW**

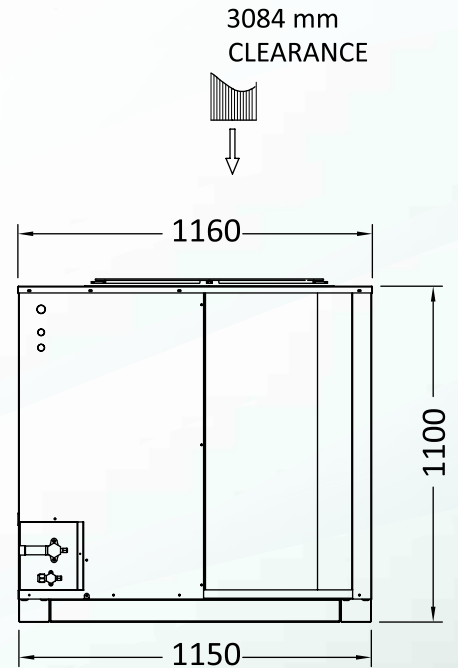

**FRONT VIEW**

**UNIT DIMENSIONS**

**Indoor Unit**

**NGEF-130**

ALL DIMENSIONS ARE IN MM

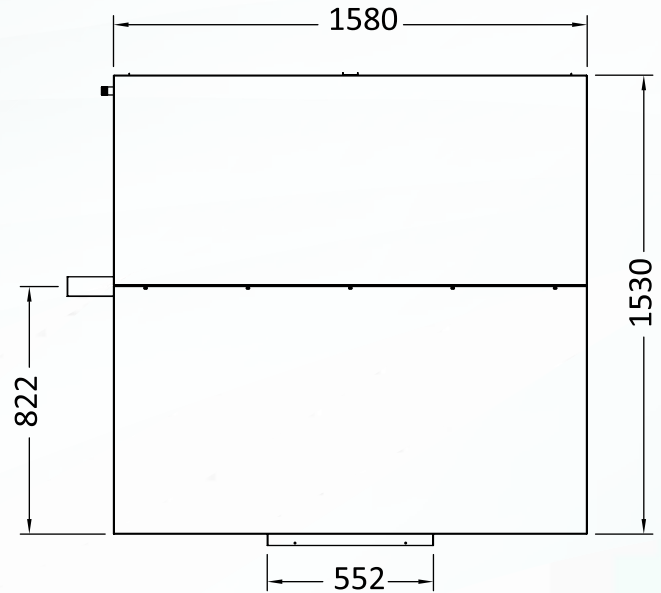

**TOP VIEW**

Ø34.9 SUCTION CONN.  
 Ø15.9 LIQUID CONN.  
 Ø42.0 DRAIN CONN.

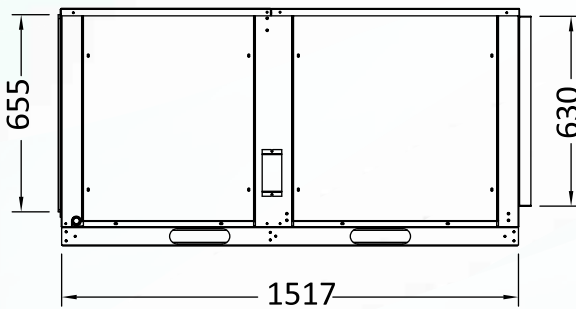

**SIDE VIEW**

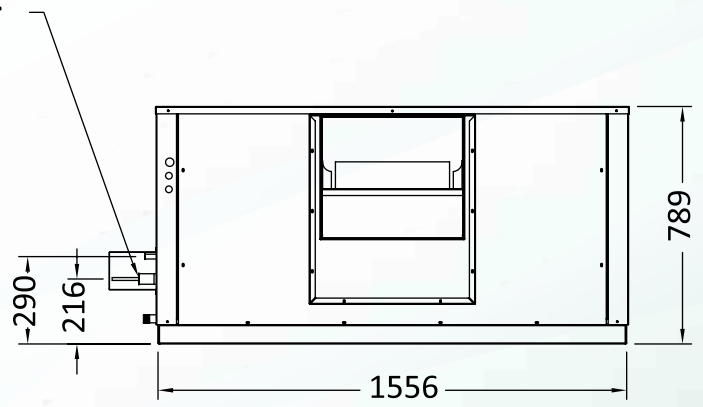

**FRONT VIEW**

**UNIT DIMENSIONS**

**Outdoor Unit**

**NGCF-130**

ALL DIMENSIONS ARE IN MM

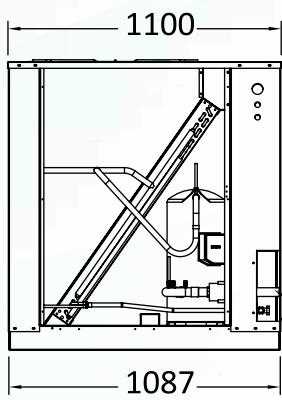
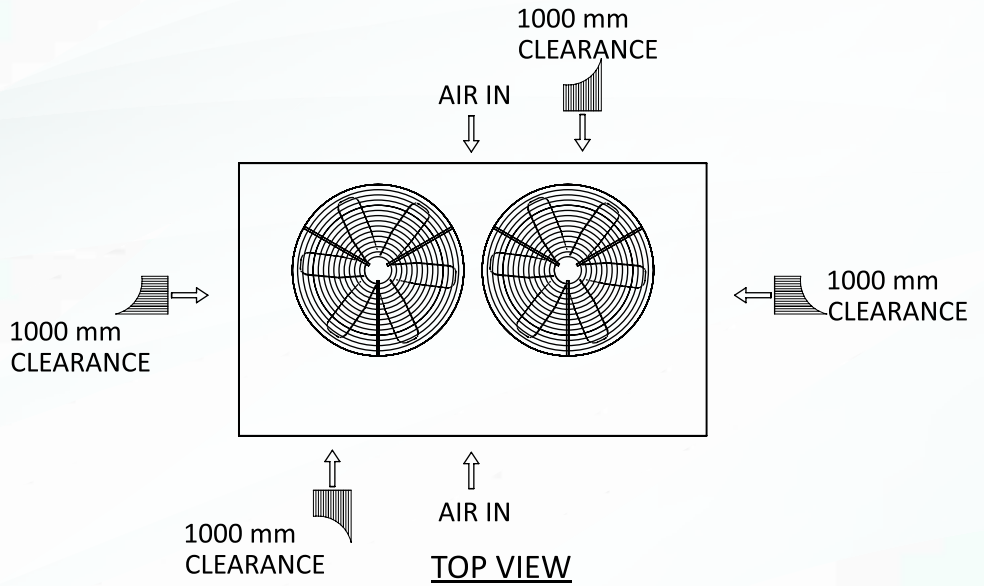

**SIDE VIEW**

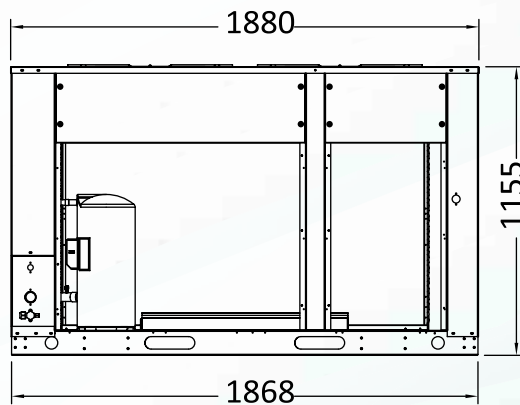

**FRONT VIEW**

**UNIT DIMENSIONS**

**Indoor Unit**

**NGEF-150**

ALL DIMENSIONS ARE IN MM

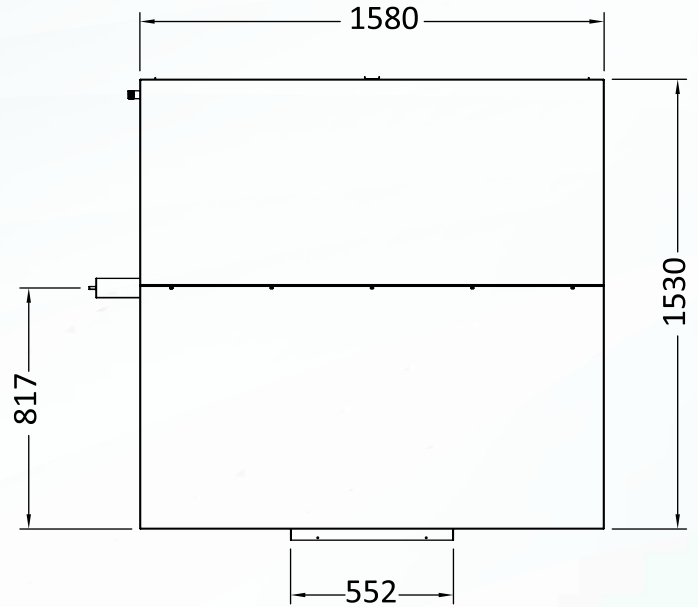

**TOP VIEW**

Ø22.2 SUCTION CONN.  
 Ø12.7 LIQUID CONN.  
 Ø42.0 DRAIN CONN.

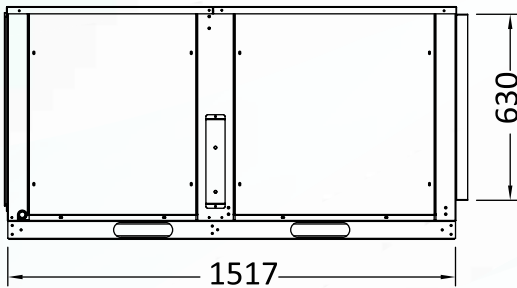

**SIDE VIEW**

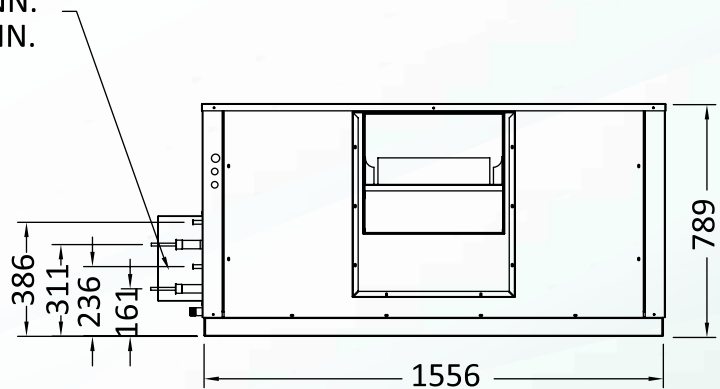

**FRONT VIEW**

**UNIT DIMENSIONS**

**Outdoor Unit**

**NGCF-150**

ALL DIMENSIONS ARE IN MM

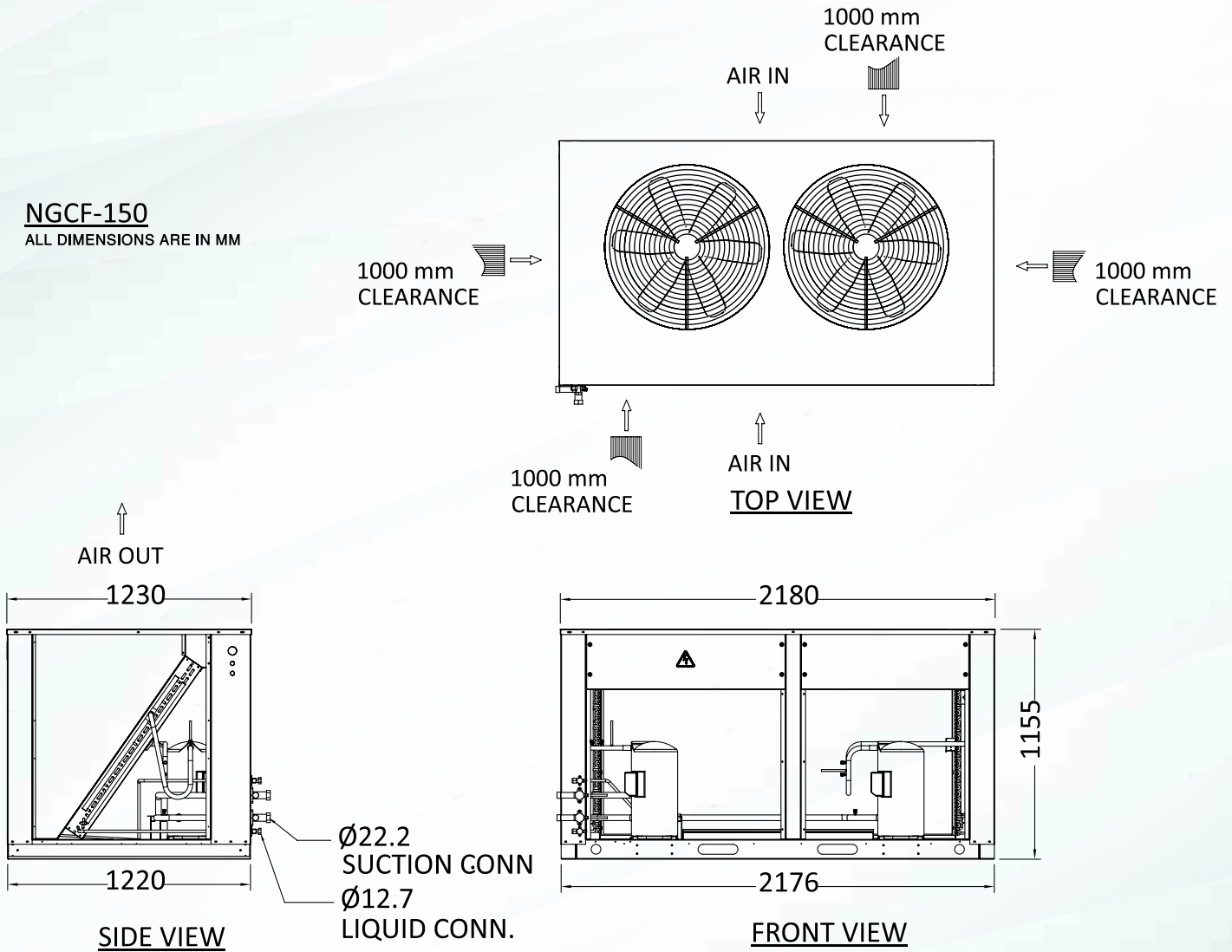

**UNIT DIMENSIONS**

**Indoor Unit**

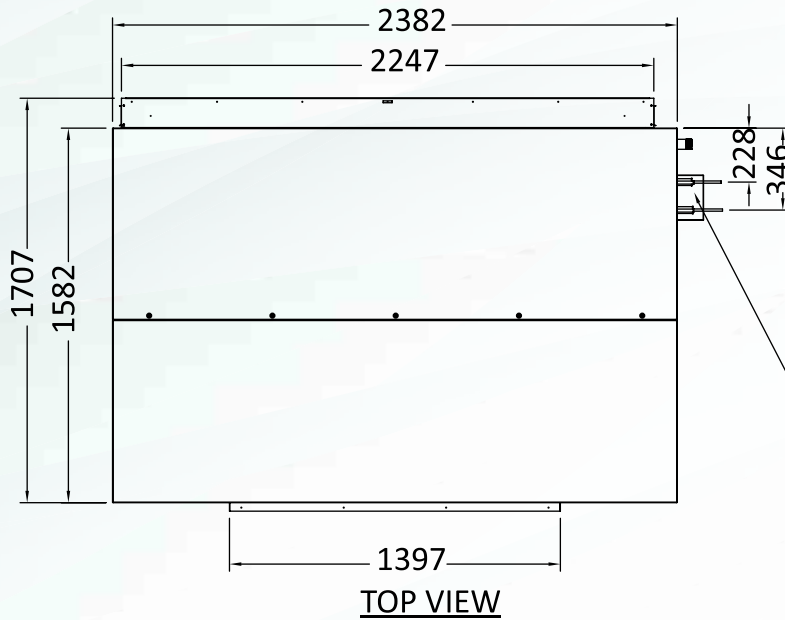

**NGEF-175/200**  
ALL DIMENSIONS ARE IN MM

Ø28.6 SUCTION CONN.  
Ø12.7 LIQUID CONN.  
Ø42.0 DRAIN CONN.

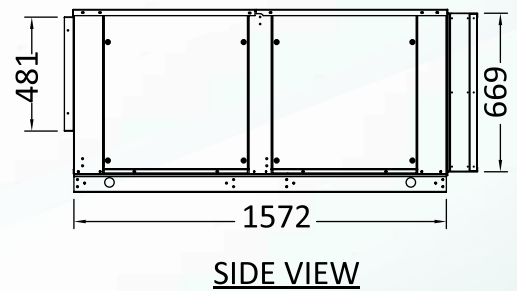
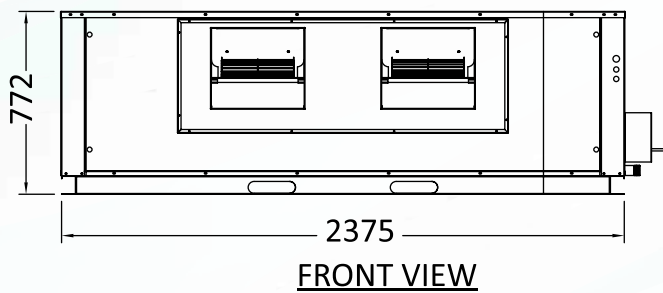

**UNIT DIMENSIONS**

**Outdoor Unit**

**NGCF-175**

ALL DIMENSIONS ARE IN MM

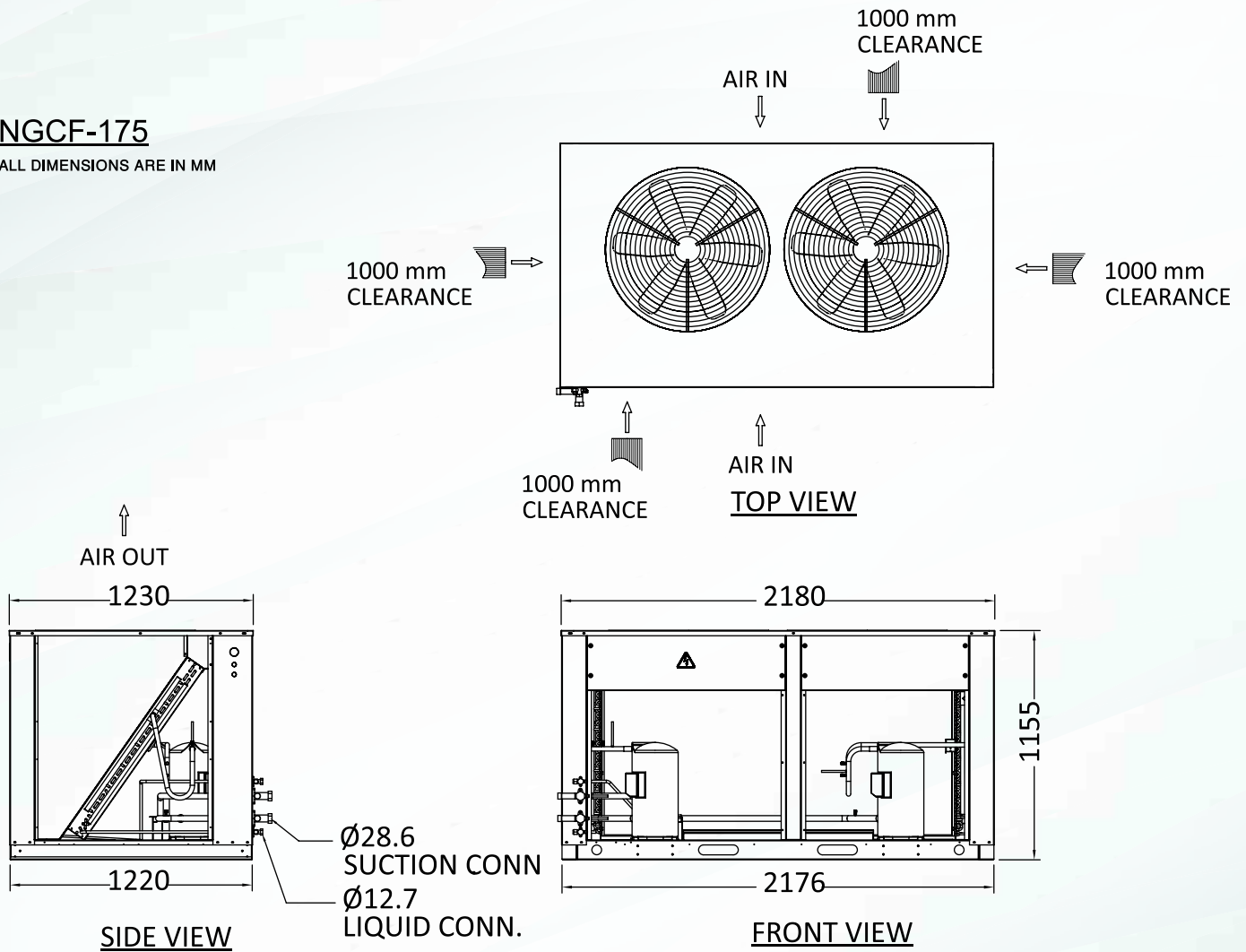

**UNIT DIMENSIONS**

**Outdoor Unit**

**NGCF-200**

ALL DIMENSIONS ARE IN MM

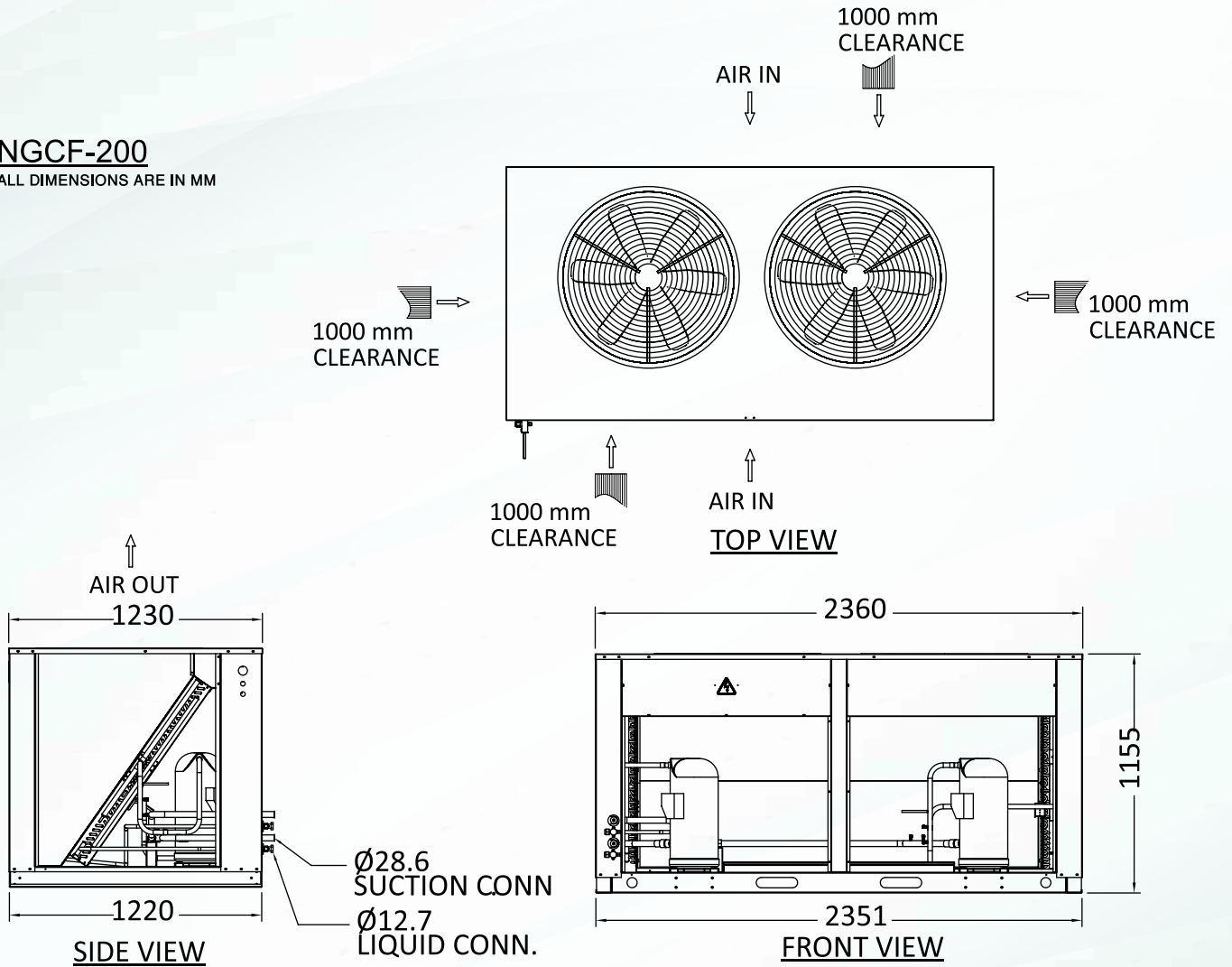

**UNIT DIMENSIONS**

**Indoor Unit**

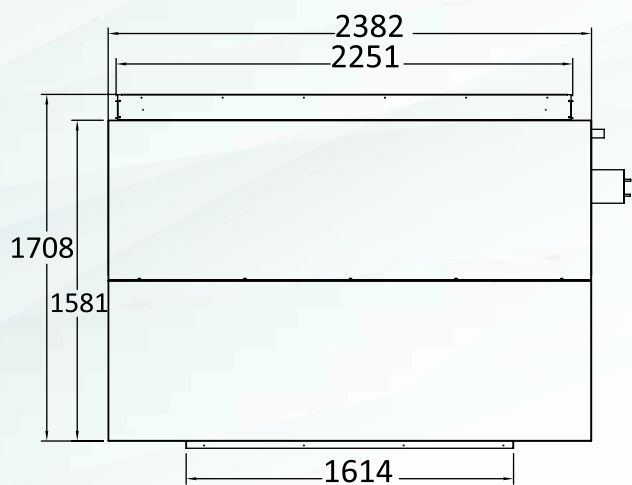

**TOP VIEW**

**NGEF-240**

ALL DIMENSIONS ARE IN MM

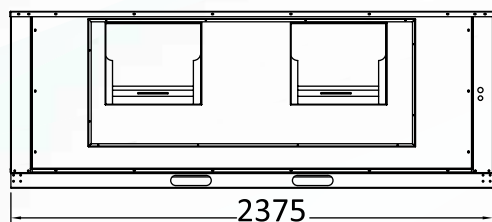

**FRONT VIEW**

- Ø5/8 LIQUID CONN.
- Ø3/8 SUCTION CONN.
- Ø42.0 DRAIN CONN.

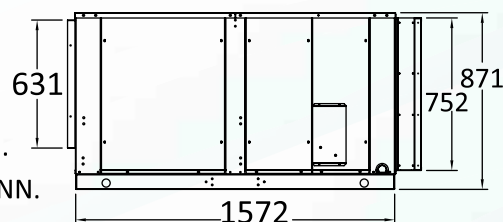

**SIDE VIEW**

**UNIT DIMENSIONS**

**Outdoor Unit**

**NGCF-240**

ALL DIMENSIONS ARE IN MM

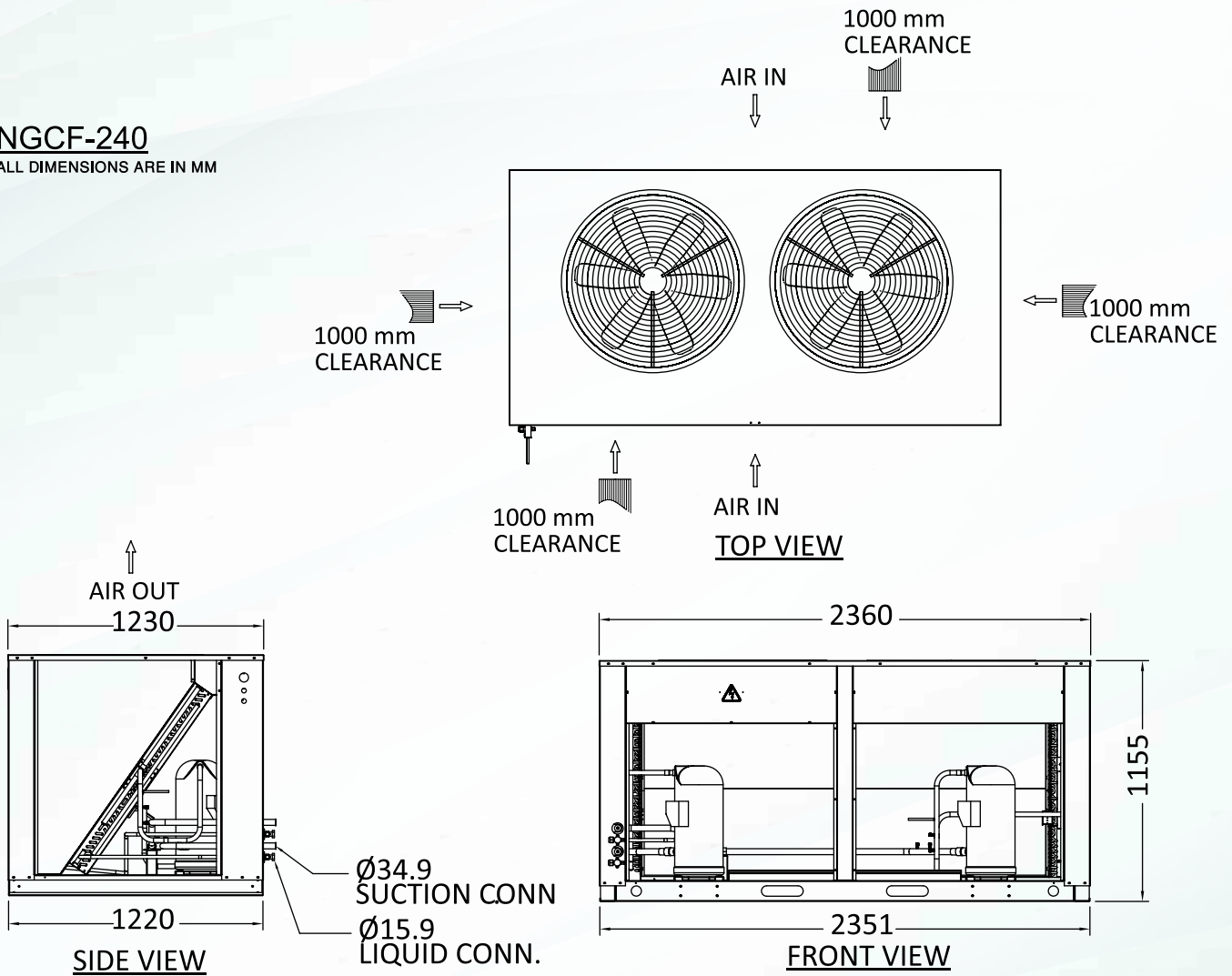

**UNIT DIMENSIONS**

**Indoor Unit**

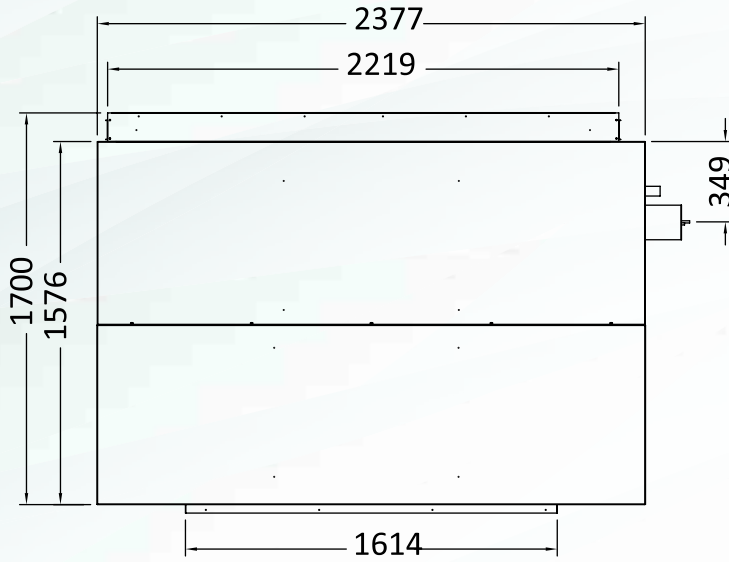

TOP VIEW

**NGEF-270/300**

ALL DIMENSIONS ARE IN MM

Ø34.9 SUCTION CONN.  
Ø15.9 LIQUID CONN.  
Ø42.0 DRAIN CONN.

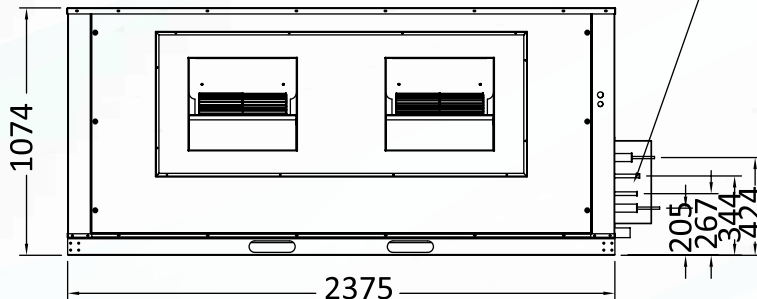

FRONT VIEW

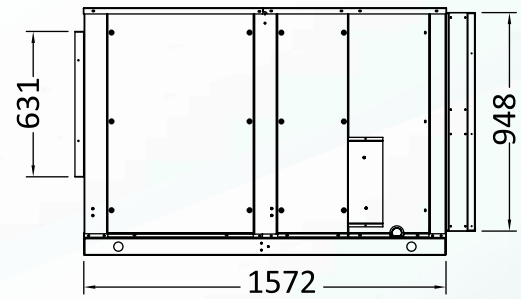

SIDE VIEW

**UNIT DIMENSIONS**

**Indoor Unit**

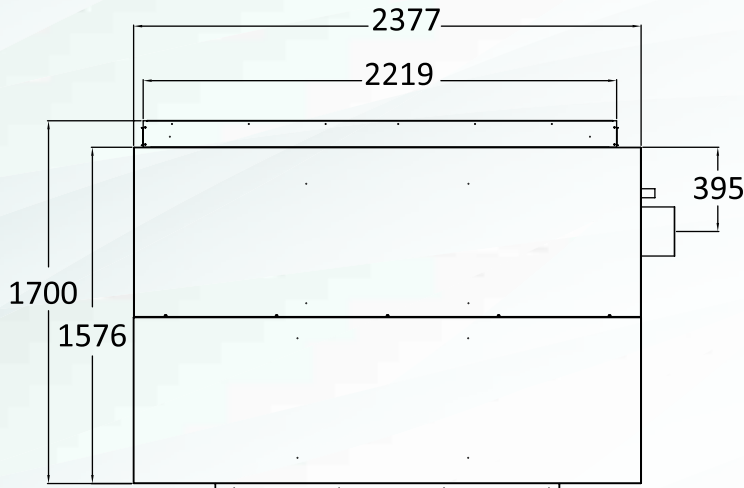

TOP VIEW

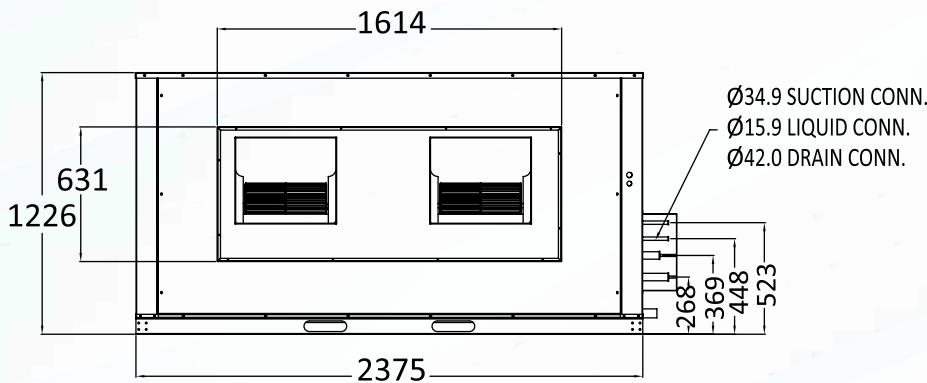

FRONT VIEW

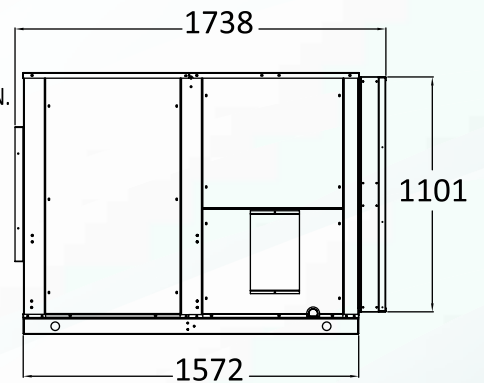

SIDE VIEW

**NGEF-320/340**

ALL DIMENSIONS ARE IN MM

**UNIT DIMENSIONS**

**Outdoor Unit**

**NGCF-270/300/320**

ALL DIMENSIONS ARE IN MM

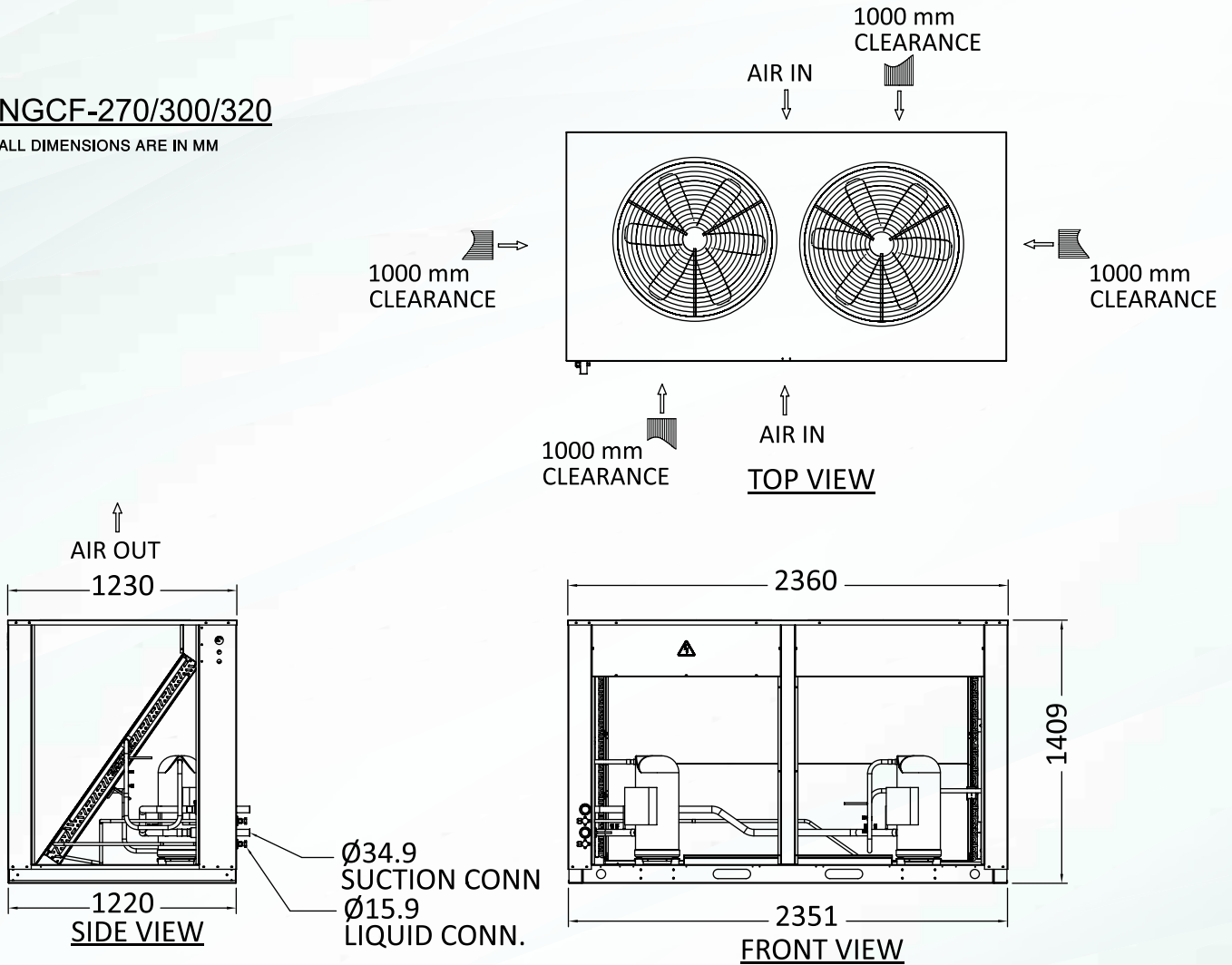

UNIT DIMENSIONS

Outdoor Unit

NGCF-340

ALL DIMENSIONS ARE IN MM

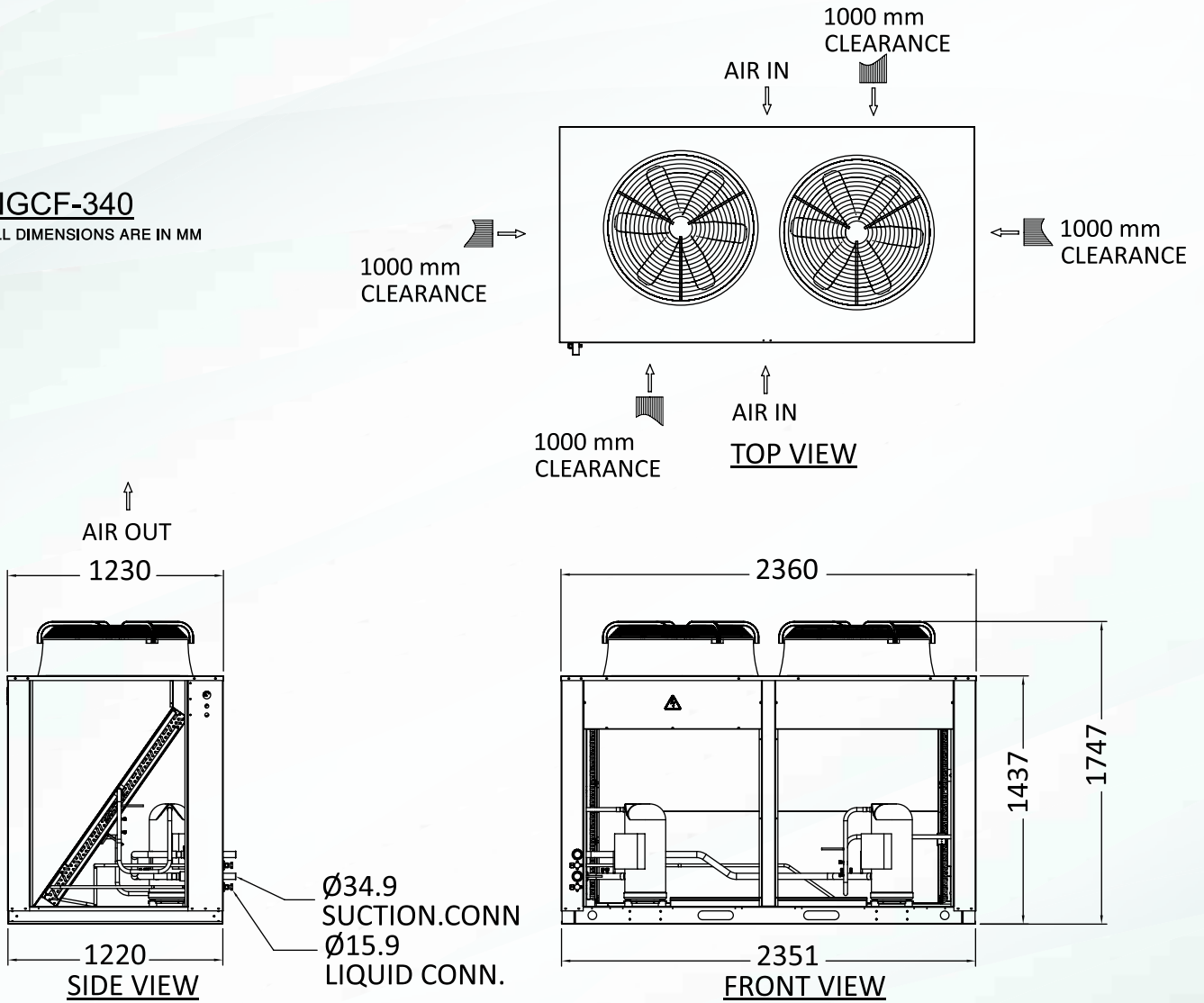

TYPICAL WIRING DIAGRAMS

OUTDOOR UNIT  
(1COMP. & 1FAN)  
COOL ONLY

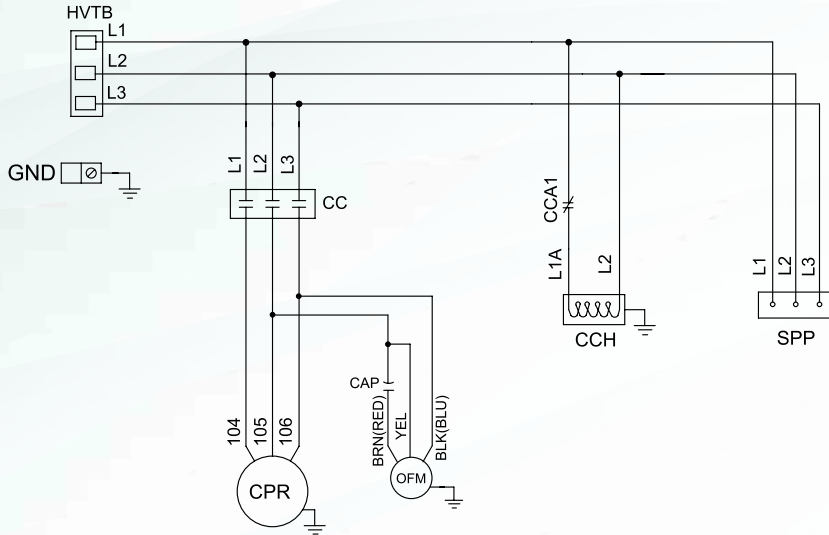

LEGEND:

- CAP - CAPACITOR
- CC - COMPRESSOR CONTACTOR
- CCA - COMPRESSOR CONTACTOR AUXILIARY
- CCH - CRANKCASE HEATER
- CPR - COMPRESSOR MOTOR
- HPS - HIGH PRESSURE SWITCH
- HVTB - HIGH VOLTAGE TERMINAL BLOCK
- LPS - LOW PRESSURE SWITCH
- GND - GROUND TERMINAL
- LVTB - LOW VOLTAGE TERMINAL BLOCK
- OFM - OUTDOOR FAN MOTOR
- SPP - SINGLE PHASE PREVENTER
- TDS - TIME DELAY SWITCH
- TRANS- TRANSFORMER
- - TERMINAL, CONTROL VOLTAGE
- - FACTORY WIRES & DEVICES
- - FIELD WIRES BY OTHERS

NOTES

1. ANY WIRE REPLACEMENT, SHOULD BE OF THE 105°C TYPE OR ITS EQUIVALENT.
2. USE COPPER CONDUCTORS ONLY.
3. POWER MUST BE SUPPLIED TO CRANKCASE HEATER FOR A MINIMUM OF 12 HOURS, PRIOR TO SYSTEM START UP. IF POWER SUPPLY HAS BEEN INTERRUPTED FOR A PROLONGED PERIOD, OIL SUMP HEATERS MUST BE ENERGIZED FOR 12 HRS MINIMUM, BEFORE STARTING COMPRESSOR.
4. FUSED DISCONNECT SWITCH OR CIRCUIT BREAKER TO BE PROVIDED BY THE USER, AS PER ELEC. DATA IN INSTALLATION MANL.
5. COMPRESSOR IS PROVIDED WITH INTERNAL OVERLOAD.
6. ALL FIELD WIRING TO COMPLY WITH NEC OR LOCAL CODE

PRESSURE SWITCH SETTINGS

NAME	OPEN (PSIG)	CLOSE (PSIG)
LPS	25 ± 5	42 ± 5
HPS	450 ± 15	360 ± 15

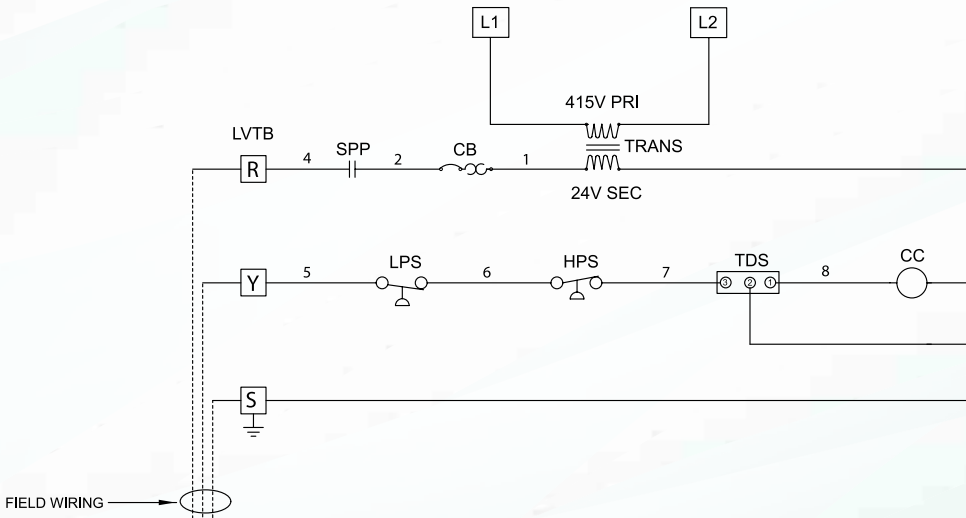

LEGEND:

- ATB - AUXILIARY TERMINAL BLOCK
- BMC - BLOWER MOTOR CONTACTOR
- ITP - INTERNAL THERMAL PROTECTOR
- IBM - INDOOR BLOWER MOTOR
- LVTB - LOW VOLTAGE TERMINAL BLOCK
- - TERMINAL, CONTROL VOLTAGE
- - FACTORY WIRES & DEVICES
- - FIELD WIRES BY OTHERS
- - DEVICES BY OTHERS

NOTES

1. ANY WIRE REPLACEMENT, SHOULD BE OF THE 105°C TYPE OR ITS EQUIVALENT.
2. USE COPPER CONDUCTORS ONLY.
3. FUSED DISCONNECT SWITCH OR CIRCUIT BREAKER TO BE PROVIDED BY THE USER, AS PER ELEC. DATA IN INSTALLATION MANL.
4. ALL FIELD WIRING SHALL BE AS PER NEC OR LOCAL CODES.

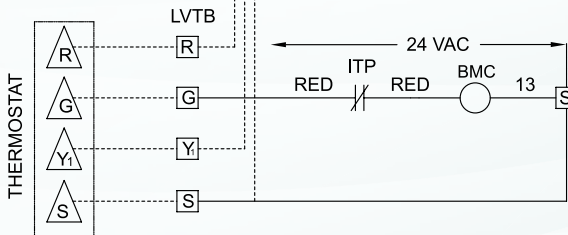

INDOOR UNIT  
COOL ONLY

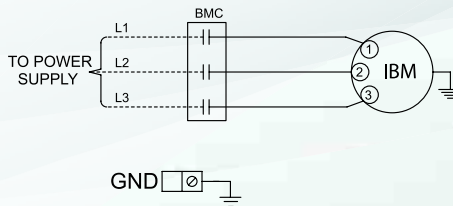

TYPICAL WIRING DIAGRAMS

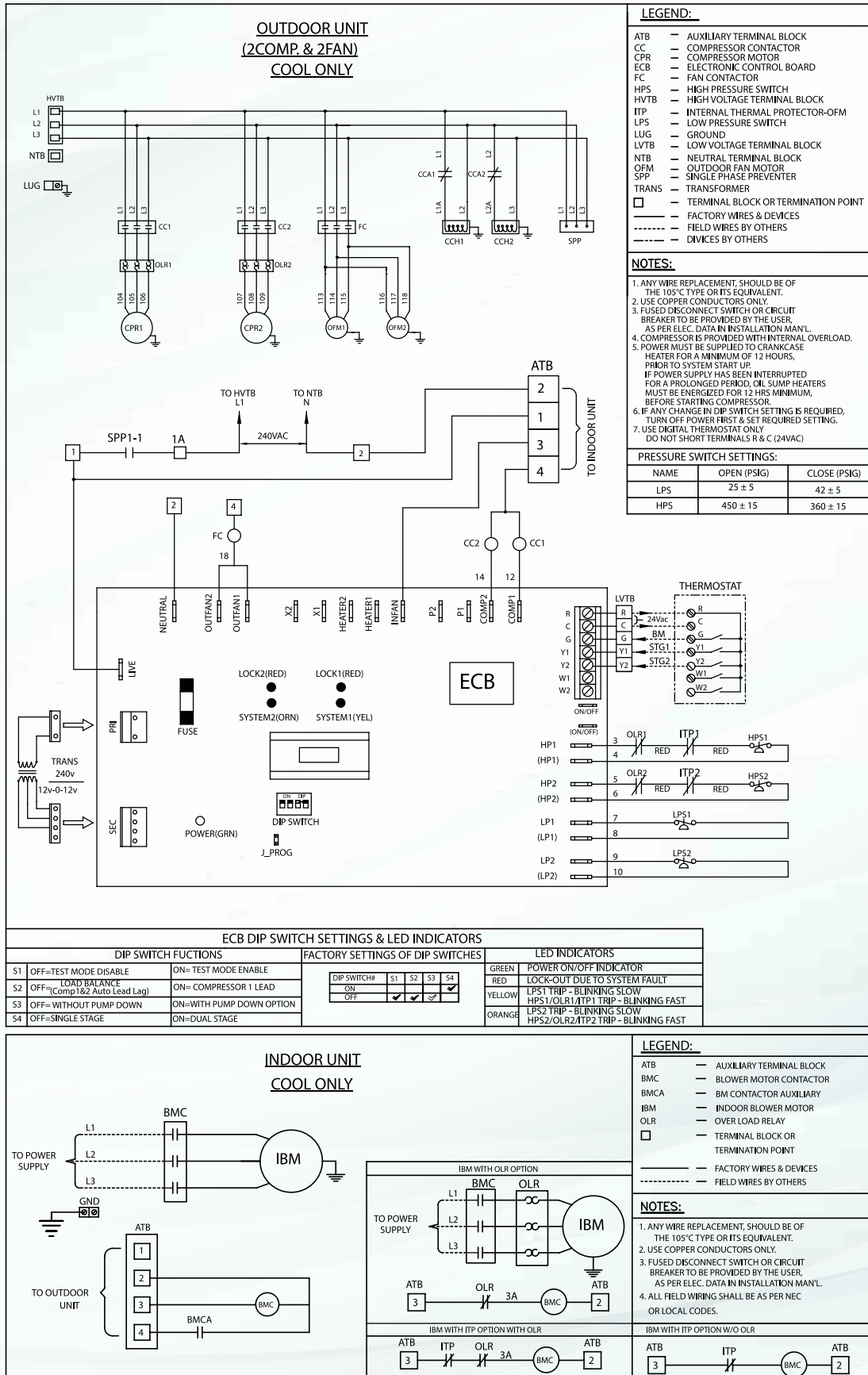

**LOAD DISTRIBUTION**

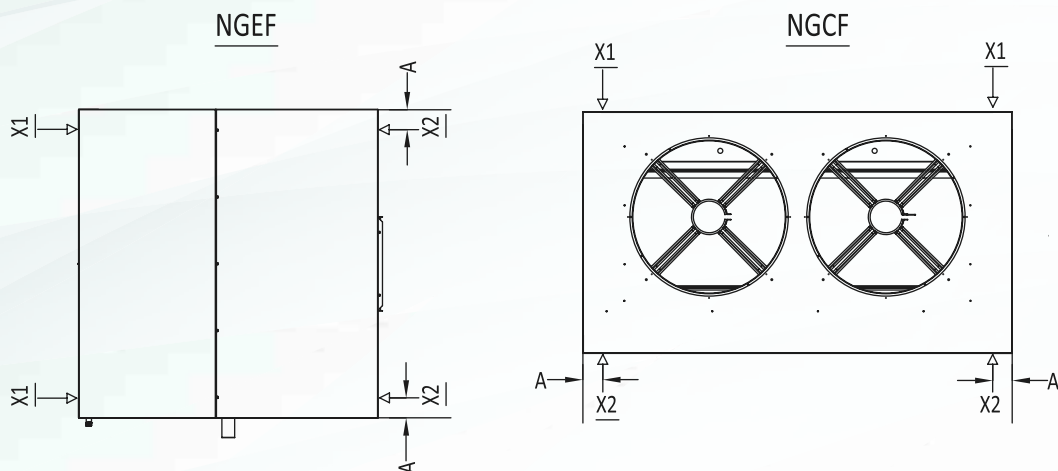

MODEL	LOAD DISTRIBUTION		
	A (mm)	X1 (kg)	X2 (kg)
NGEF-076	75.0	50	57
NGEF-090	75.0	55	63
NGEF-100	75.0	58	66
NGEF-120	75.0	60	68
NGEF-130	75.0	63	70
NGEF-150	75.0	65	72
NGEF-175	75.0	71	77
NGEF-200	75.0	72	79
NGEF-240	75.0	93	101
NGEF-270	75.0	98	106
NGEF-300	75.0	111	121
NGEF-320	75.0	115	124
NGEF-340	75.0	122	132
NGCF-076	75.0	91	84
NGCF-090	75.0	93	86
NGCF-100	75.0	108	99
NGCF-120	75.0	116	107
NGCF-130	75.0	123	113
NGCF-150	75.0	130	141
NGCF-175	75.0	132	143
NGCF-200	75.0	133	145
NGCF-240	75.0	172	187
NGCF-270	75.0	182	197
NGCF-300	75.0	207	224
NGCF-320	75.0	217	234
NGCF-340	75.0	222	239





## شركة صناعات التبريد والتخزين والخدمات النفطية

Refrigeration Industries & Storage and Oil Services Co. KSC



Ref no.: CSDF-26-5-000

# CONTACT US

---



**T : +965 183 33 80**

**w : [www.coolex.com.kw](http://www.coolex.com.kw)**

**Sulaibiya Industrial, Block 1,  
Road 4, Plot No. 105.**