

Variable Refrigerant Flow IVCF Series

86-154 MBH (8-16 HP)



50/60 Hz



R410a
Environment Friendly

TABLE OF CONTENT

ABOUT THE COMPANY	02
INTRODUCTION	03
NOMENCLATURE	03
OUTSTANDING FEATURES	05
CONTROL SYSTEM	11
GENERAL DATA	12
UNIT ELECTRICAL DATA	13
UNIT RATING SUMMARY	14
CEILING CONCEALED SPECIFICATIONS	16
CEILING CASSETTE SPECIFICATIONS	18
WALL MOUNTED SPECIFICATIONS	19
UNIT DIMENSIONS	20
WIRING DIAGRAM	25

ABOUT THE COMPANY

Refrigeration Industries & Storage and Oil Services Company, occupies a leading position as one of the largest industrial companies in Kuwait which established in 1973, it plays a proactive role in providing various services and diverse activities such as manufacturing, storage, and oil services to meet the needs of customers both inside and outside Kuwait.

Since its inception, RIC has been committed to excellence and advancing its progress, leading to the establishment of the brand (Coolex) in 1986, a true milestone in the Kuwaiti market as the first in the region in the sector of manufacturing air conditioning systems and cooling solutions.

Furthermore, the company has consistently empowered its workforce, enhanced safety and competitiveness, and utilized innovative technologies to launch new products that meet the needs of various sectors, contributing to expansion and supporting growth and prosperity.

To ensure the highest performance in the future, RIC harnesses its continuous research to enhance efficiency and quality, while continuing its efforts to manufacture products capable of adapting to climate, environmental, and energy challenges.



Facts throughout the years

- 1973 Warehouses were established by Amiri Decree.
- 1979 RIC Constructed the Medical Cold Stores Complex, the world's largest at that time.
- 1980 RIC Air Conditioning manufacturing plant set up in Sulaibya.
- 1981 Production of Package & Mini-Split A/Cs started under York-Gulf.
- 1984 RIC was listed in Kuwait Stock Exchange.
- 1986 COOLEX brand Production Launched.
- 1991 RIC rebuilt the manufacturing plant destroyed during the war.
- 1997 Achieved ISO Certification ISO 9001:1994.
- 2002 ETL Designed testing lab became fully operational.
- 2004 Privatization of RIC.
- 2010 COOLEX becomes the first A/C Unit to Pass MEW's new regulations.
- 2010 RIC Factory Renovation and Expansion into neighboring countries.
- 2012 Achieved UL & AHRI Certification for Coolex Units.
- 2014 Achieved SASO Certification for Concealed Ducted Split Series.
- 2014 Achieved EUROVENT Certification for Air Handling Units AHU.
- 2014 Achieved UL Certification for Air Cooled Chillers.
- 2015 Achieved ISO 17025 Certification for Psychrometric Laboratory.
- 2016 Achieved Energy Efficiency Certification for Concealed Ducted Split Series & Rooftop Package units (Kingdom of Bahrain).
- 2016 Acquisition of Gulf Paramount for Electrical Services Company.
- 2021 Acquisition of Kuwait Pipes Industries & Oil Services factory, resulting in a change of the company's name from Refrigeration Industries & Storage Co. to Refrigeration Industries & Storage and Oil Services Co.

INTRODUCTION

COOLEX's high-efficiency, next-generation VRF system is engineered and manufactured to deliver reliable climate solutions for hospitals, offices, villas, shops, and other applications operating in high ambient conditions. Each unit incorporates inverter-driven compressors and DC brushless fan motors for optimal performance and energy efficiency.

NOMENCLATURE VRF INDOOR UNIT

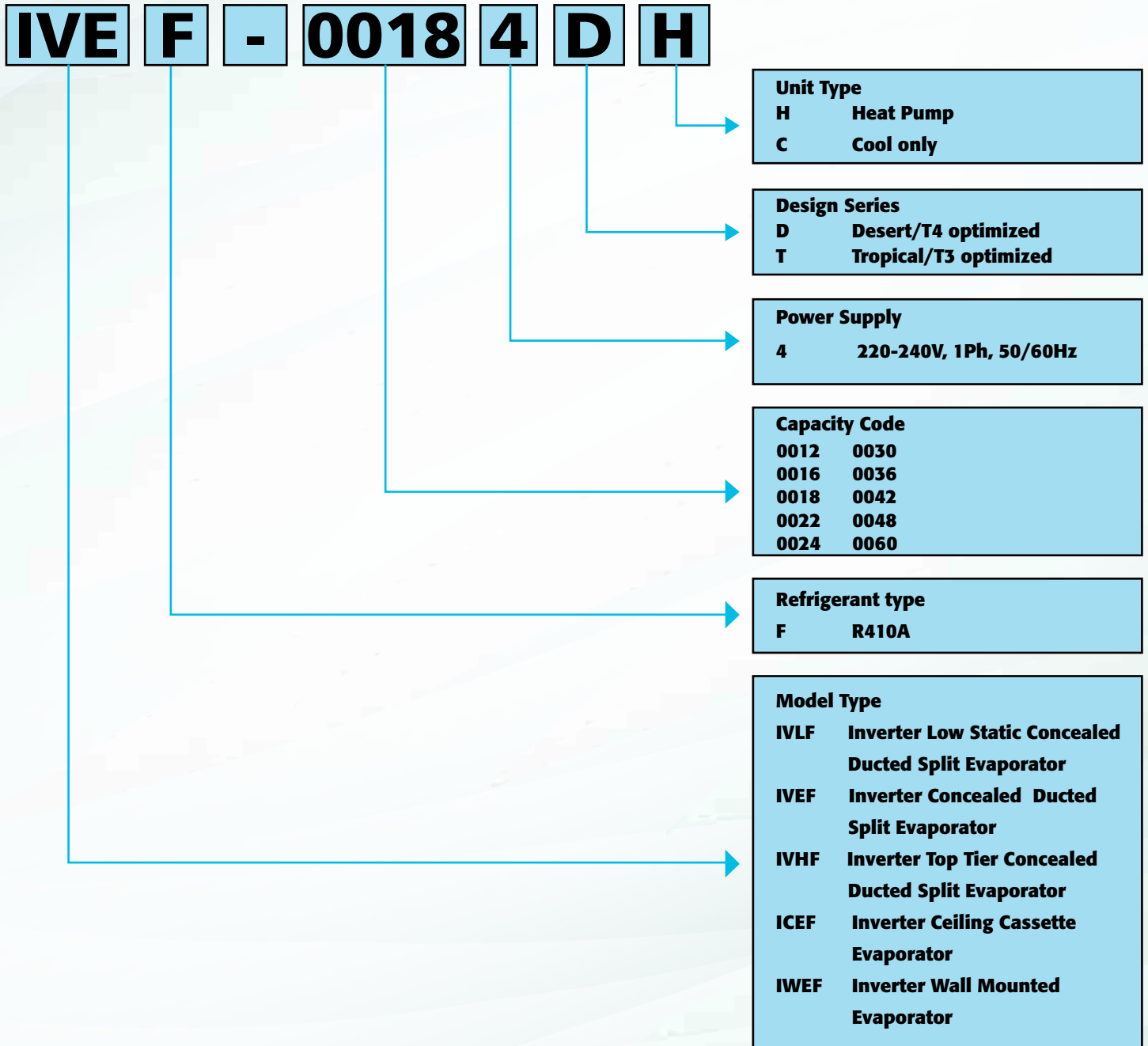

NOMENCLATURE VRF OUTDOOR UNIT

IVC F - 0095 6 C D H

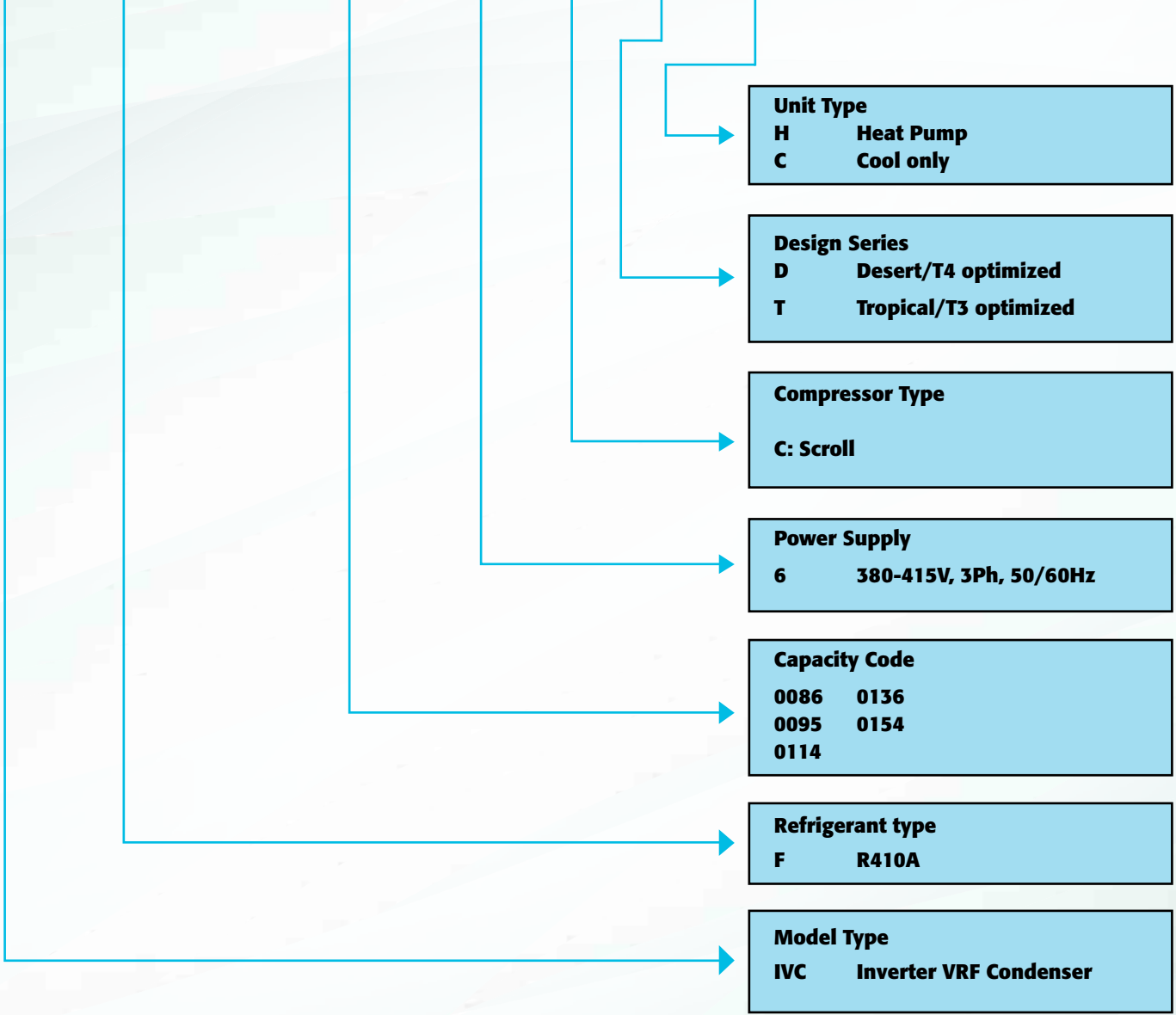

Unit Type
H Heat Pump
C Cool only

Design Series
D Desert/T4 optimized
T Tropical/T3 optimized

Compressor Type
C: Scroll

Power Supply
6 380-415V, 3Ph, 50/60Hz

Capacity Code
0086 0136
0095 0154
0114

Refrigerant type
F R410A

Model Type
IVC Inverter VRF Condenser

OUTSTANDING FEATURES

Tropical Series

Outdoor Unit



Environment Friendly-R410A

R410a



Multiple Protection

The system includes comprehensive protection mechanisms to ensure safe and reliable operation. These include high-pressure and low-pressure protection, compressor temperature protection, phase sequence and phase loss protection, overheating and anti-freezing safeguards, as well as sensor failure alarms. These features help maintain compressor operation within a safe and stable range.

Double Anti-Corrosion Technology

The outdoor unit housing is constructed from galvanized metal and finished with high-performance powder coating. This combination significantly enhances corrosion resistance, particularly in saline and humid environments.

Up To 55°C Running

The unit delivers stable performance in ambient temperatures up to 55 °C, making it suitable for T4 climatic conditions.

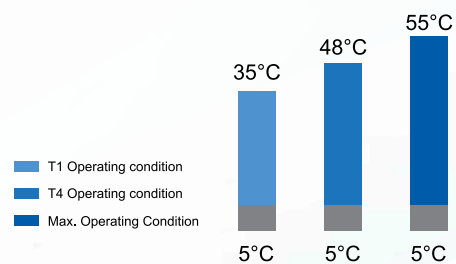

Wide Operation Range

The unit is designed to operate reliably in ambient temperatures up to 55 °C, ensuring consistent cooling performance even during extreme summer conditions.

Fire-proof Electrical Box

The electrical control box features a redesigned enclosure that enhances fire safety by reducing the risk of internal ignition caused by electrical arcing or component failure.

Self-Diagnostic Function

During abnormal operation or system failure, the unit's microprocessor monitors key parameters and automatically shuts down if necessary to protect critical components. Error or protection codes are displayed on the indoor wired controller for quick identification and service response.

OUTSTANDING FEATURES

DC Inverter Compressor

Pressure relief valve structure

Improving the partial load efficiency, adapt to the transformer ratio working condition, improving the compressor performance.

Dynamic oil balance structure

Oil balance tube implementation parallel compressor and oil quantity dynamic equilibrium, ensuring the reliability of several paralleled compressors.

High efficiency motor configuration

Using high quality material concentrated stator, cooperate with neodymium magnet rotor, having outstanding efficiency.

High pressure cavity structure

Large exhaust buffer volume, reducing the air flow noise and vibration of the runtime.

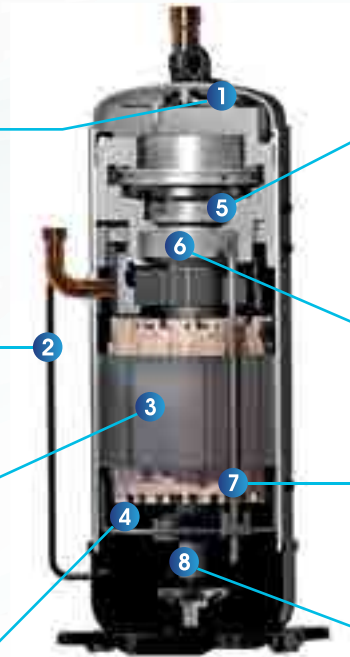

The intermediate pressure servo mechanism

According to the operation pressure among dynamic adjusting middle pressure, has realized the axial flexible, optimization of dynamic vortex disk meshing, improve product performance.

High reliability of the bearing

Adopt cylinder bearing and self-aligning ball bearing group, improving the reliability of the compressor.

Internal oil circulation structure

Lubricating oil to achieve internal circulation, reducing heat loss, decreasing the rate of spilling oil, improve the efficiency and reliability.

Positive displacement gear oil pump

Positive displacement gear oil pump to ensure the high and low frequency can satisfy the oil supply, improving the reliability of the compressor.

High Efficiency Fan Assembly

The fan motor features microprocessor-controlled variable-speed operation, adjusting continuously in response to system load and operating conditions. This intelligent control minimizes energy consumption and ensures stable, high-performance airflow across all operating scenarios.

Silence Operation

The outdoor unit operates with low noise levels thanks to its EC brushless condenser fan motor assembly. This efficient design reduces sound emissions during normal operation, ensuring quiet performance.

OUTSTANDING FEATURES

High EER

The Coolex VRF Series air conditioner delivers high cooling performance and energy efficiency through full DC control. It features a DC inverter compressor, DC indoor fan motor, DC outdoor fan motor, and a DC electronic expansion valve—resulting in quiet operation and optimized energy use.

Blue Coated Aluminum fin

The unit utilizes louvered, coated aluminum fins to improve thermal transfer efficiency, which increases overall cooling/heating capacities.

Auto Restart Function

In the event of a power interruption, the air conditioner automatically stores its last operating settings. When power is restored, it resumes operation with the previous configuration—eliminating the need for manual restart.

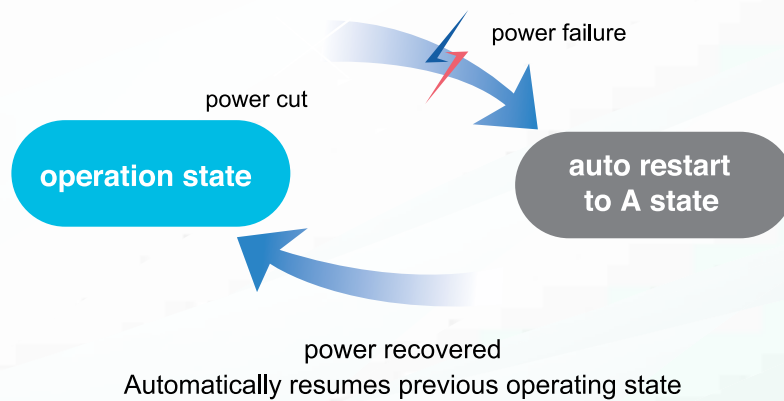

Fast Cooling

The compressor quickly reaches its target operating frequency, enabling a timely increase in cooling capacity and reducing the duration needed to achieve the set temperature.

180° Sine Wave Control

The DC inverter system utilizes 180° sine wave drive technology, offering a broader operating range for both frequency and voltage. This results in improved energy efficiency, smoother operation, and reduced noise levels.

Hydrophilic Blue Coated Fins

The unit employs hydrophilic blue-coated aluminum fins, which help reduce microbial growth, improve heat transfer efficiency, and lower air pressure drop across the coil—enhancing airflow without compromising thermal performance.

OUTSTANDING FEATURES

Tropical Series

INDOOR UNIT



Precise Temperature Control

COOLEX technology adjusts outdoor output and indoor airflow based on operating conditions, enabling $\pm 0.5^{\circ}\text{C}$ temperature precision.



The EEV uses a PI control algorithm to calculate indoor capacity demand based on room temperature, and adjusts refrigerant flow precisely to regulate compressor frequency in real time.

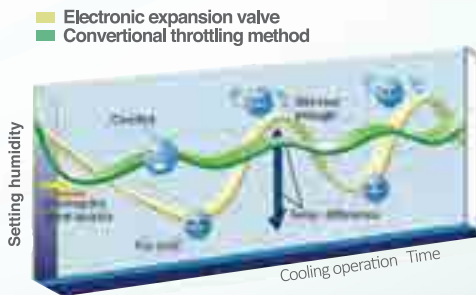
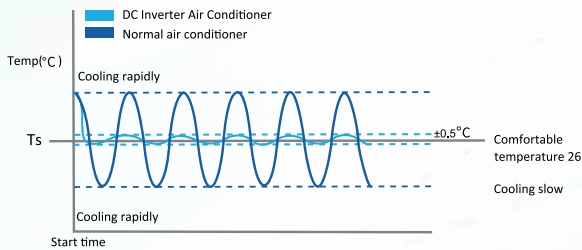

Indoor Unit Quiet Operation

The indoor unit supports three fan speed settings, allowing users to select an airflow level that manages noise output while maintaining comfort.

OUTSTANDING FEATURES

Ceiling Concealed

- Compact design
- Low sound power level
- Ducted and duct free application
- 3 speed DC motor
- Easy maintenance
- Easy installation
- Washable filter

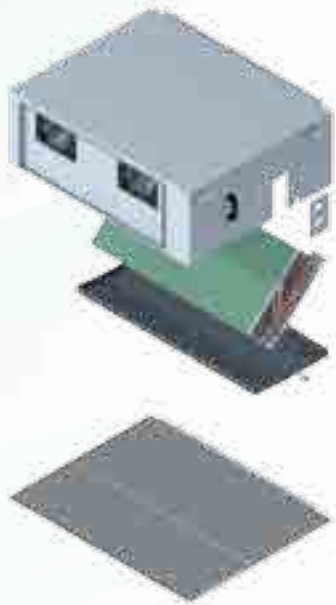

Bottom coil and drain pan removal



Bottom access for easy maintenance



Bottom fan deck removal

OUTSTANDING FEATURES

Ceiling Cassette

Easy maintenance:

The simple design concept has provided the ease of maintenance and servicing. Access to the internal part of the unit can be from the Front Panel.

High Performance Centrifugal Fan:

Light Weight, Aero-Dynamical Design made of San+20% Glass field, Highly efficient fans, with higher airflow rate, draws more cooling across the Evaporating unit leading to greater cooling capacity.

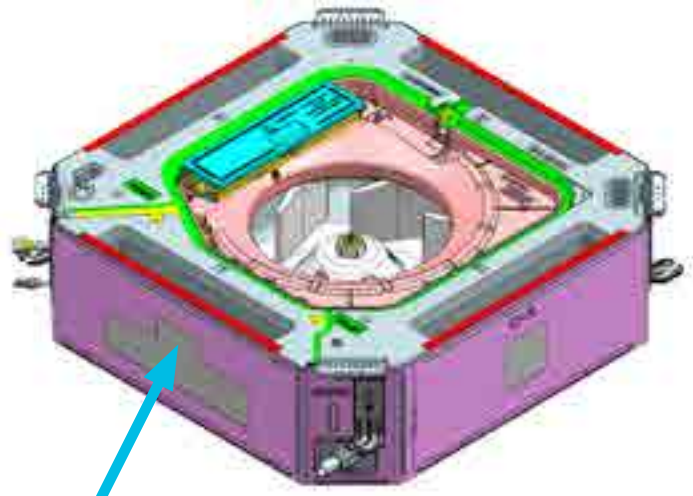

Room To Room Ducting Provision (Marked As "1" And "3" On Eps Drain)

Wall Mounted

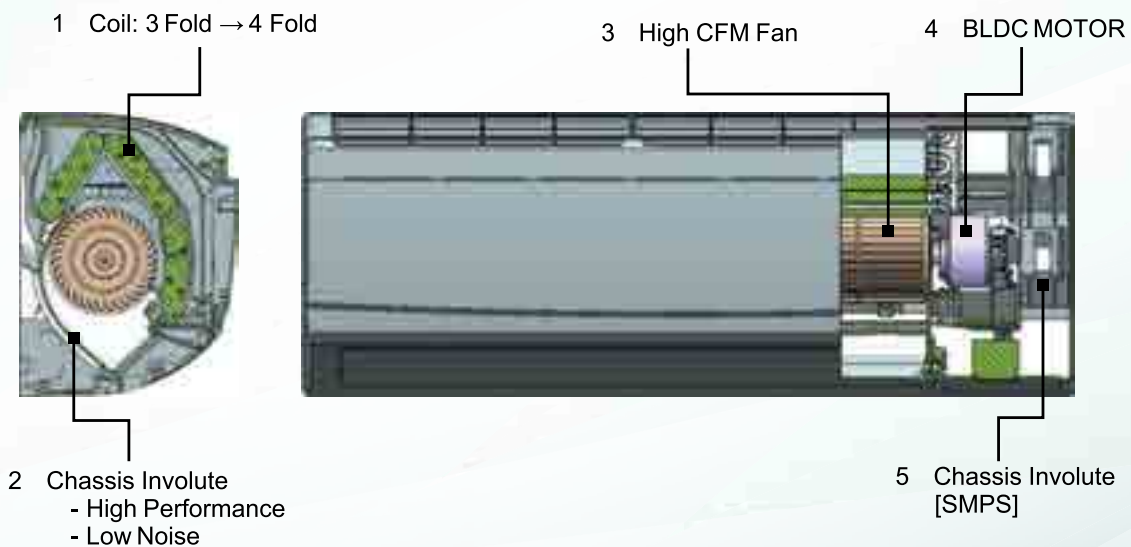

- Modern and attractive designs
- High-Performance Fan and Heat Exchanger
- Low Noise Operation
- Operation Mode: Cool/Auto/Fan/Heating

CONTROL SYSTEM

User friendly thermostat design

The compact design allows the controller to be discreetly installed in hotels, hospitals, schools, and offices. A standard backlight makes it easy to operate in low-light conditions.

LED Display

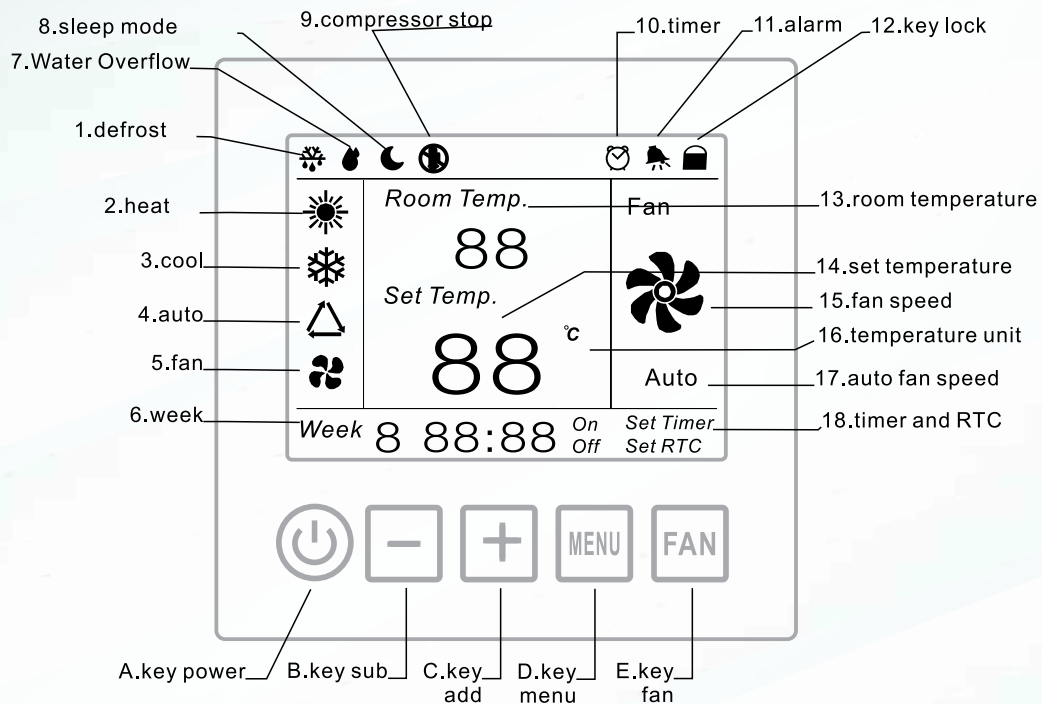

COOLEX MICROCOMPUTER INVERTER TECHNOLOGY

The new generation of VRF units features a technologically advanced system logic-based controller, enabling the following benefits and capabilities:

Protection and Failure Control:

- Over and under voltage protection
- Over current protection
- Power surge protection
- Indoor/Outdoor temperature protection limit
- Compressor overload protection
- Compressor overheating protection
- High and Low pressure switch protection
- Reverse phase protection (for 3 phase system)
- Anti freeze protection
- Time delay protection for compressor
- Anti short cycle timer
- Outdoor condenser sensor failure
- Outdoor ambient temp. sensor failure
- Indoor evaporator sensor failure

GENERAL DATA

IVCF TROPICAL TYPE FULL DC INVERTER VRF SYSTEM 380V - 415V, 50/60Hz, 3Ph

COOLING CAPACITY BTU/HR (KW)			86,000 (25.2)	95,000 (27.8)	114,000 (33.4)	136,000 (39.9)	158,000 (46.3)
HEATING CAPACITY BTU/HR (KW)			86,000 (25.2)	95,000 (27.8)	114,000 (33.4)	136,000 (39.9)	158,000 (46.3)
Model Name			IVCF-00866CDH	IVCF-00956CDH	IVCF-01146CDH	IVCF-01366CDH	IVCF-01546CDH
Capacity Connection Ratio		%	50 ~ 130				
Compressor	Quantity		1DC		2DC		
	Type		Hermetic Scroll				
Condenser Coil	Type		Blue Coated Aluminum Fins and IGT Copper Tubes				
	No. of Rows		3				
Fan Motor	Type		DC Motor				
	Quantity		1		2		
Outdoor Fan	Type		Axial Fan				
	Quantity		1		2		
Weight	Net		Kg.	280	282	502	504
	Pipe Diameter	Liquid	mm	Φ 12.7		Φ 15.8	
Gas		mm	Φ 22.2		Φ 28.6		
Pipe Length	Max. Actual Pipe Length		m	240			
	From 1st indoor distributor to farthest IU		m	90			
Vertical Length	Between OU & IU (OU below IU)		m	110			
	Between IU 's		m	30			

Operating Temperature Range

Cooling	Outdoor side	°C (°F)	5 - 55 (41 - 131)
	Indoor side	°C (°F)	16 ~ 32 (60.8 ~ 89.6)
Heating	Outdoor side	°C (°F)	5 - 24 (41 - 75)
	Indoor side	°C (°F)	16~32 (60.8 ~ 89.6)

UNIT ELECTRICAL DATA

Outdoor Units		IVCF-00866CDH	IVCF-00956CDH	IVCF-01146CDH	IVCF-01366CDH	IVCF-01546CDH
Unit Power Supply	Volt	380-415				
	Phase	3				
	Hz	50/60				
Compressor	V - Ph - Hz	400 /3/50-60				
	Amps	18.5	18.5	21.5	18.5(2ea)	18.5(2ea)
Condenser	V - Ph - Hz	220-240				
Fan Motor	WATTS	700	700	700	700(2ea)	700(2ea)
	FLA	4.15	4.15	4.15	4.15(2ea)	4.15(2ea)
Minimum Circuit, Ampere		27.3	27.3	31	50	50
Max. Fuse Size, Ampere		45	45	50	60	60

Indoor Units		IVEF-00184DH	IVEF-00244DH	IVEF-00304DH	IVEF-00364DH	IVEF-00424DH	IVEF-00484DH	IVEF-00604DH
Unit Power Supply	Volt	220-240						
	Phase	1						
	Hz	50/60						
Evaporator Fan Motor	V - Ph - Hz	220-240/1/50-60						
	WATTS	260	260	260	260	380	560	560
	FLA	2.5	2.5	2.5	2.5	3.3	4.7	4.7
Max. Fuse Size, Ampere		10	10	10	10	10	10	10
Connection Wire	Signal Wire Size(mm ²)	0.5(2Core shielded cable)						
	Thermostat Wire Size(mm ²)	0.5(4Core shielded cable)						

LEGEND:

FLA - Full Load Amps

UNIT RATING SUMMARY

95 °F OUTDOOR AMBIENT TEMPERATURE							
Model	Type	Qty Nos.	Cooling Capacity (Btu/Hr)	Airflow (Cfm)	Total Power (Kw)	Kw/Ton	EER
IVCF-00866CDH	Outdoor	1	87,070	3,094	6.52	0.90	13.35
IVEF-00164DH	Indoor	5					
IVCF-00956CDH	Outdoor	1	96,540	3,602	7.08	0.88	13.65
IVEF-00164DH	Indoor	6					
IVCF-01146CDH	Outdoor	1	115,334	4,238	8.59	0.89	13.43
IVEF-00164DH	Indoor	7					
IVCF-01366CDH	Outdoor	1	132,080	5,821	11.17	1.02	11.82
IVHF-00164DH	Indoor	4					
IVHF-00184DH	Indoor	4					
IVCF-01546CDH	Outdoor	1	152,550	6,964	13.54	1.07	11.26
IVHF-00164DH	Indoor	10					

115 °F OUTDOOR AMBIENT TEMPERATURE							
Model	Type	Qty Nos.	Cooling Capacity (Btu/Hr)	Airflow (Cfm)	Total Power (Kw)	Kw/Ton	EER
IVCF-00866CDH	Outdoor	1	69,300	3,000	6.36	1.10	10.09
IVEF-00164DH	Indoor	5					
IVCF-00956CDH	Outdoor	1	79,580	3,600	7.11	1.07	11.2
IVEF-00164DH	Indoor	6					
IVCF-01146CDH	Outdoor	1	95,500	4,200	8.60	1.06	11.1
IVEF-00164DH	Indoor	7					
IVCF-01366CDH	Outdoor	1	108,420	5,950	11.52	1.22	9.81
IVHF-00164DH	Indoor	4					
IVHF-00184DH	Indoor	4					
IVCF-01546CDH	Outdoor	1	123,400	7,200	12.27	1.19	10.05
IVHF-00164DH	Indoor	10					

Note:

- 1.T1: Indoor side (80.6°F) 27°C DB, (66.2°F) 19°C WB ; Outdoor : (95°F) 35°C DB
- 2.T3: Indoor side (84.2°F) 29°C DB, (66.2°F) 19°C WB ; Outdoor : (115°F) 46°C DB
- 3.T4: Indoor side (80 F) 26.7C DB, (67F) 19.4C DB; Outdoor: (118.4F) 48C DB
4. Capacity in KW = (Btu/Hr/12000)*3.517. Cooling capacities are gross rating.
5. Combination Ratio : 100 %

UNIT RATING SUMMARY

118 °F OUTDOOR AMBIENT TEMPERATURE							
Model	Type	Qty Nos.	Cooling Capacity (Btu/Hr)	Airflow (Cfm)	Total Power (Kw)	Kw/Ton	EER
IVCF-00866CDH	Outdoor	1	65,376	3,242	6.53	1.20	10.02
IVEF-00164DH	Indoor	5					
IVCF-00956CDH	Outdoor	1	75,070	3,708	7.23	1.16	10.38
IVEF-00164DH	Indoor	6					
IVCF-01146CDH	Outdoor	1	90,094	4,365	8.71	1.16	10.34
IVEF-00164DH	Indoor	7					
IVCF-01366CDH	Outdoor	1	105,885	5,885	11.43	1.30	9.26
IVHF-00164DH	Indoor	4					
IVHF-00184DH	Indoor	4					
IVCF-01546CDH	Outdoor	1	118,201	7,176	12.46	1.27	9.48
IVHF-00164DH	Indoor	10					

Note:

- 1.T1: Indoor side (80.6°F) 27°C DB, (66.2°F) 19°C WB ; Outdoor : (95°F) 35°C DB
- 2.T3: Indoor side (84.2°F) 29°C DB, (66.2°F) 19°C WB ; Outdoor : (115°F) 46°C DB
- 3.T4: Indoor side (80 F) 26.7C DB, (67F) 19.4C DB; Outdoor: (118.4F) 48C DB
4. Capacity in KW = (Btu/Hr/12000)*3.517. Cooling capacities are gross rating.
5. Combination Ratio : 100 %

CEILING CONCEALED SPECIFICATIONS



LOW STATIC

Model Name	Power Type	Rated Capacity				Fan Motor (DC)	Airflow	Expansion Device	Evaporator Coil			Body Weight	Connecting Pipe (Diameter)			Std. Controller
		Cooling		Heating					Net	Type	Rows		Kg	Gas	Liquid	
		kW	BTU/Hr	kW	BTU/Hr	Watts	CFM	Type				Type				mm (inch)
IVLF-00184DH	220-240V, 50/60Hz, 1Ph	5.0	17,000	5.4	18,400	90	550	Electronic Expansion Valve	Blue Coated	3	20	15.88 (5/8)	9.52 (3/8)	DN20 (R3/4)	Wired Controller	
IVLF-00244DH		6.7	23,000	7.3	24,800	90	750		Aluminum	3	20					
IVLF-00304DH		8.5	29,000	9.2	31,300	50/90	950		Fins and	3	33					
IVLF-00364DH		10.3	35,000	11.1	37,800	50/90	1,100		IGT Copper Tubes	3	33					



MEDIUM STATIC

Model Name	Power Type	Rated Capacity				Fan Motor (DC)	Airflow	Expansion Device	Evaporator Coil			Body Weight	Connecting Pipe (Diameter)			Std. Controller
		Cooling		Heating					Net	Type	Rows		Kg	Gas	Liquid	
		kW	BTU/Hr	kW	BTU/Hr	Watts	CFM	Type				Type				mm (inch)
IVEF-00164DH	220-240V, 50/60Hz, 1Ph	4.8	16,500	5.2	17,800	245	600	Electronic Expansion Valve	Blue Coated Aluminum Fins and IGT Copper Tubes	3	40	15.88 (5/8)	9.52 (3/8)	DN20 (R3/4)	Wired Controller	
IVEF-00184DH		5.3	18,000	5.7	19,400	245	600			2	60					
IVEF-00244DH		7.0	24,000	7.6	25,900	245	800			3	63					
IVEF-00304DH		8.8	30,000	9.5	32,400	245	1,000			3	63					
IVEF-00364DH		10.6	36,000	11.4	38,900	245	1,200			3	71					
IVEF-00424DH		12.3	42,000	13.4	45,400	375	1,400			3	71					
IVEF-00484DH		14.1	48,000	15.2	51,800	552	1,600			4	78					
IVEF-00604DH		17.6	60,000	19.1	64,800	552	2,000			3	91					
																19.05 (3/4)

- Notes:
- Cooling Capacity : Indoor side (80.6°F) 27°C DB, (66.2°F) 19°C WB ; Outdoor : (95°F) 35°C DB, (75.2°F) 24°C WB
 - Heating Capacity: Indoor side (68°F) 20°C DB ; Outdoor : (44.6°F) 7°C DB, (42.8°F) 6°C WB
 - Piping Length : 7.5 meters with 0m level difference.
 - Above designs and specification are subject to change without prior notice.

CEILING CONCEALED SPECIFICATIONS



TOP TIER MEDIUM STATIC

Model Name	Power Type	Rated Capacity				Fan Motor (DC)	Airflow	Expansion Device	Evaporator Coil		Body Weight	Connecting Pipe (Diameter)			Std. Controller
		Cooling		Heating					Type	Rows		Net	Gas	Liquid	
		kW	BTU/Hr	kW	BTU/Hr	Watts	CFM	Type			Kg				
IVHF-00164DH	220-240V, 50/60Hz, 1Ph	4.9	16,600	5.3	17,900	245	700	Electronic Expansion Valve	Blue Coated Aluminum Fins and IGT Copper Tubes	3	40	15.88 (5/8)	9.52 (3/8)	DN20 (R3/4)	Wired Controller
IVHF-00184DH		5.6	19,000	6.0	20,500	245	750			3	63				
IVHF-00244DH		7.6	26,000	8.3	28,100	245	1,000			3	63				
IVHF-00304DH		9.4	32,000	10.2	34,600	245	1,200			3	63				
IVHF-00364DH		11.1	38,000	12.1	41,000	245	1,400			3	71				
IVHF-00424DH		12.9	44,000	13.9	47,500	375	1,600			3	71				
IVHF-00484DH		14.7	50,000	15.9	54,000	552	1,800			4	78				
IVHF-00604DH		18.2	62,000	19.7	66,900	552	2,200			4	95				

Notes:

1. Cooling Capacity : Indoor side (80.6°F) 27°C DB, (66.2°F) 19°C WB ; Outdoor : (95°F) 35°C DB, (75.2°F) 24°C WB
2. Heating Capacity: Indoor side (68°F) 20°C DB ; Outdoor : (44.6°F) 7°C DB, (42.8°F) 6°C WB
3. Piping Length : 7.5 meters with 0m level difference.
4. Above designs and specification are subject to change without prior notice.

CEILING CASSETTE SPECIFICATIONS



Model Name	Power Type	Rated Capacity				Motor Input Watts	Airflow CFM	Expansion Device Type	Evaporator Coil		Body Weight /+ (Panel)		Connecting Pipe (Diameter)			Std. Controller
		Cooling		Heating					Type	Rows	Net Kg	Gross Kg	Gas mm (inch)	Liquid mm (inch)	Drain mm (inch)	
		kW	BTU/Hr	kW	BTU/Hr											
ICEF-00184DH	220-240V,	5.3	18,000	5.7	19,400	60.0	720	Electronic Expansion Valve	Blue Coated	2	5.5	8.0	12.70 (1/2)	6.35 (1/4)	DN20 (R3/4)	Remote Controller
ICEF-00244DH		6.4	24,000	7.6	25,900	60.0	750		Aluminum	2						
ICEF-00364DH	50/60Hz,	10.6	36,000	11.4	38,900	95.0	1,280		Fins and IGT Copper	3			15.88 (5/8)	9.52 (3/8)		
ICEF-00484DH	1Ph	14.1	48,000	15.2	51,800	95.0	1,280		Tubes	3						

Notes:

1. Cooling Capacity : Indoor side (80.6°F) 27°C DB, (66.2°F) 19°C WB ; Outdoor : (95°F) 35°C DB, (75.2°F) 24°C WB
2. Heating Capacity: Indoor side (68°F) 20°C DB ; Outdoor : (44.6°F) 7°C DB, (42.8°F) 6°C WB
3. Piping Length : 7.5 meters with 0m level difference.
4. Above designs and specification are subject to change without prior notice.

WALL MOUNTED SPECIFICATIONS

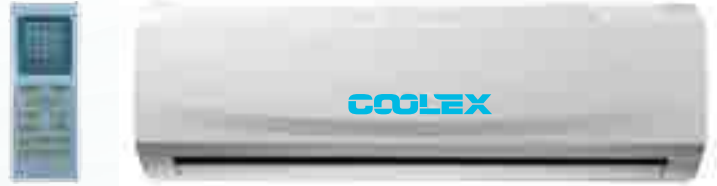

Model Name	Power Type	Rated Capacity				Motor Input	Airflow	Expansion Device	Evaporator Coil			Body Weight	Connecting Pipe (Diameter)			Std. Controller
		Cooling		Heating					Type	Type	Rows		Net	Gas	Liquid	
		kW	BTU/Hr	kW	BTU/Hr							Watts				
IWEF-00124DH	220-240V,	3.5	12,000	3.8	12,900	30.0	470	Electronic Expansion Valve	Blue Coated Aluminum Fins and IGT Copper Tubes	2	9.3	12.70 (1/2)	6.35 (1/4)	DN20 (R3/4)	Remote Controller	
IWEF-00184DH		5.3	18,000	5.7	19,400	30.0	650				11.0					
IWEF-00244DH	50/60Hz, 1Ph	7.0	24,000	7.6	25,900	57.0	800		3	13.8	15.88 (5/8)					
IWEF-00304DH		8.8	30,000	9.5	32,400	57.0	800			14.2						

Notes:

1. Cooling Capacity : Indoor side (80.6°F) 27°C DB, (66.2°F) 19°C WB ; Outdoor : (95°F) 35°C DB, (75.2°F) 24°C WB
2. Heating Capacity: Indoor side (68°F) 20°C DB ; Outdoor : (44.6°F) 7°C DB, (42.8°F) 6°C WB
3. Piping Length : 7.5 meters with 0m level difference.
4. Above designs and specification are subject to change without prior notice.

UNIT DIMENSIONS (INDOOR UNIT)

CEILING CONCEALED

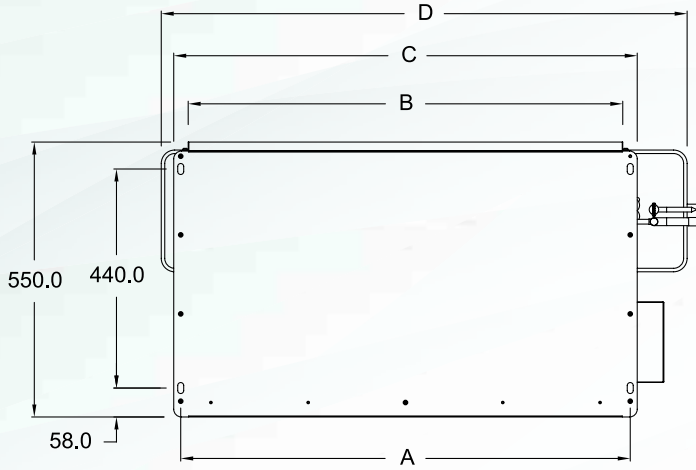

TOP VIEW

MODEL	DIMENSIONS			
	A	B	C	D
IVLF-0018	900	870	930	1,055
IVLF-0024	900	870	930	1,055
IVLF-0030	1,350	1,320	1,377	1,505
IVLF-0036	1,350	1,320	1,377	1,505

ALL DIMENSIONS ARE IN MM

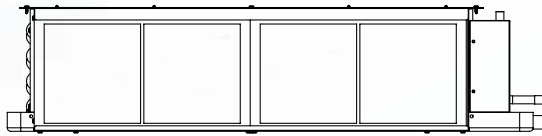

FRONT VIEW

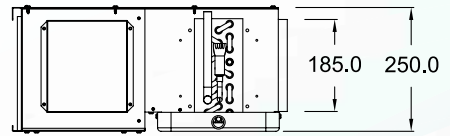

SIDE VIEW

UNIT DIMENSIONS (INDOOR UNIT)

CEILING CONCEALED

IVEF-00164DH

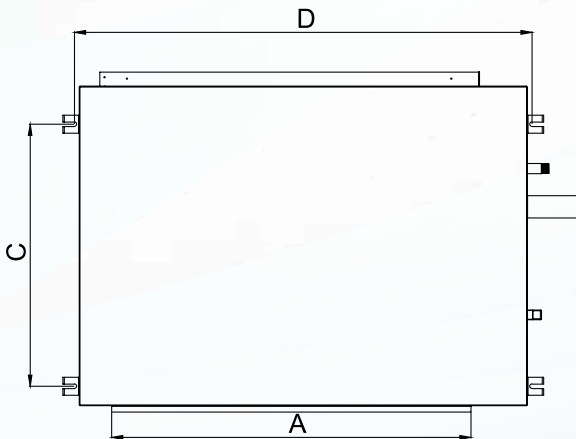
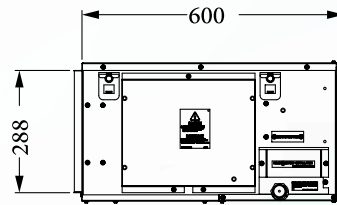
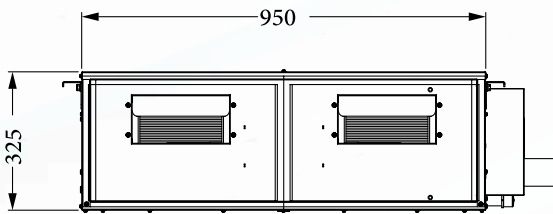
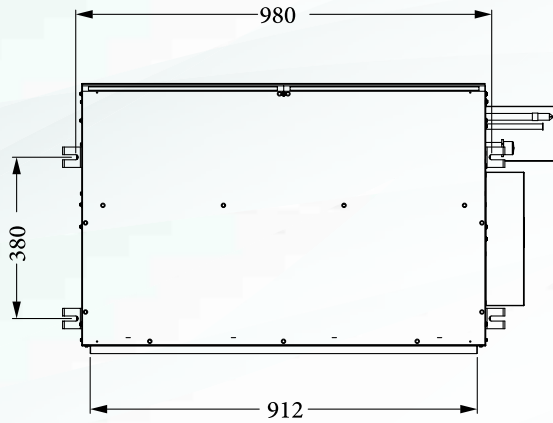

MODEL	DIMENSIONS					
	L	W	H	DUCT DIMENSIONS AxB	C	D
IVHF-0016DH	1,100	790	351	864x309	614	1,128
IVEF/IVHF-0018DH	1,100	790	351	864x309	614	1,128
IVEF/IVHF-0024DH	1,100	790	351	864x309	614	1,128
IVEF/IVHF-0030DH	1,100	790	351	864x309	614	1,128
IVEF/IVHF-0036DH	1,200	855	396	964x354	703	1,228
IVEF/IVHF-0042DH	1,200	855	396	964x354	703	1,228
IVEF/IVHF-0048DH	1,200	855	396	964x354	703	1,228
IVEF/IVHF-0060DH	1,325	890	435	1,164x393	704	1,428

ALL DIMENSIONS ARE IN MM

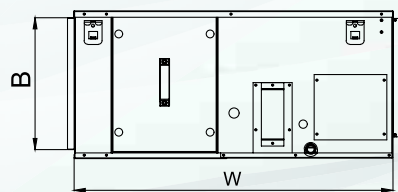
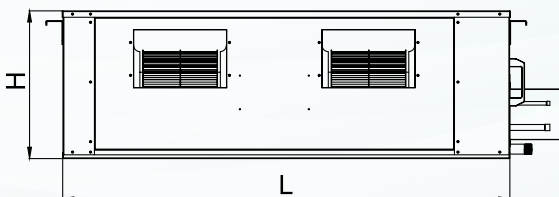

UNIT DIMENSIONS (INDOOR UNIT)

CEILING CASSETTE

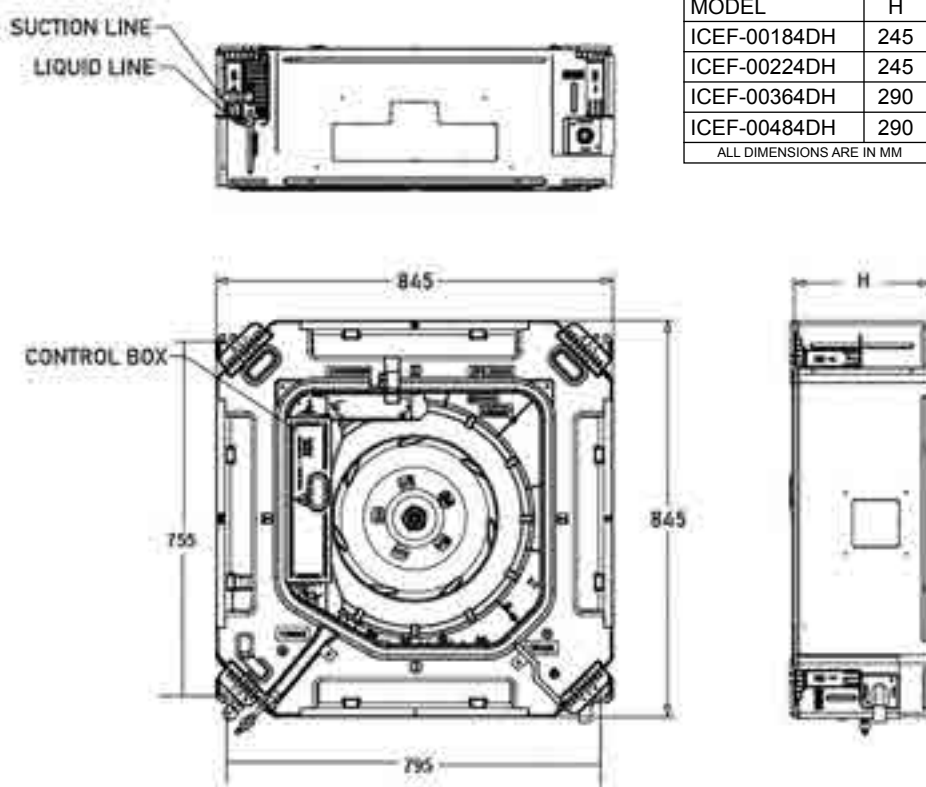

MODEL	H
ICEF-00184DH	245
ICEF-00224DH	245
ICEF-00364DH	290
ICEF-00484DH	290

ALL DIMENSIONS ARE IN MM

WALL MOUNTED

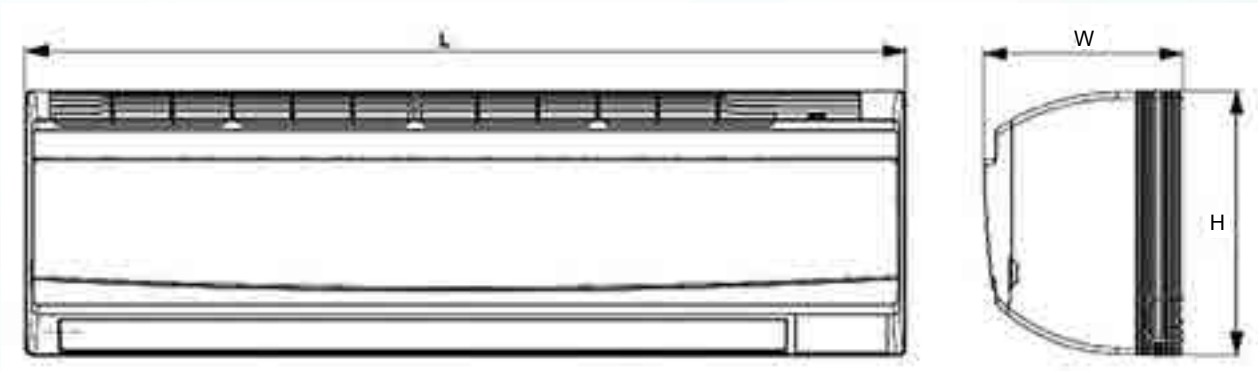

MODEL	L	H	W
IWEF-00124DH	800	295	230
IWEF-00184DH	1000	295	230
IWEF-00244DH	1100	330	250
IWEF-00304DH	1100	330	250

ALL DIMENSIONS ARE IN MM

UNIT DIMENSIONS (OUTDOOR UNIT)

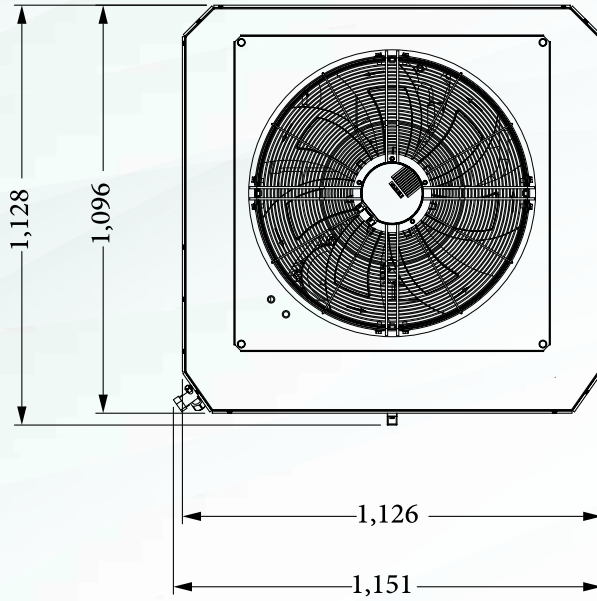

IVCF-00866CDH/
IVCF-00956CDH/
IVCF-01146CDH

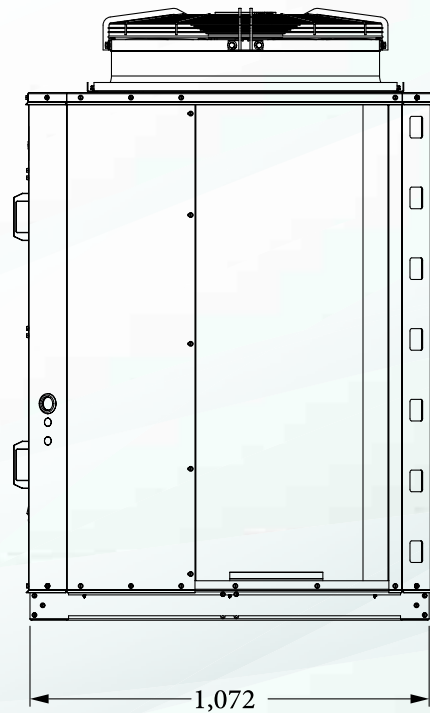
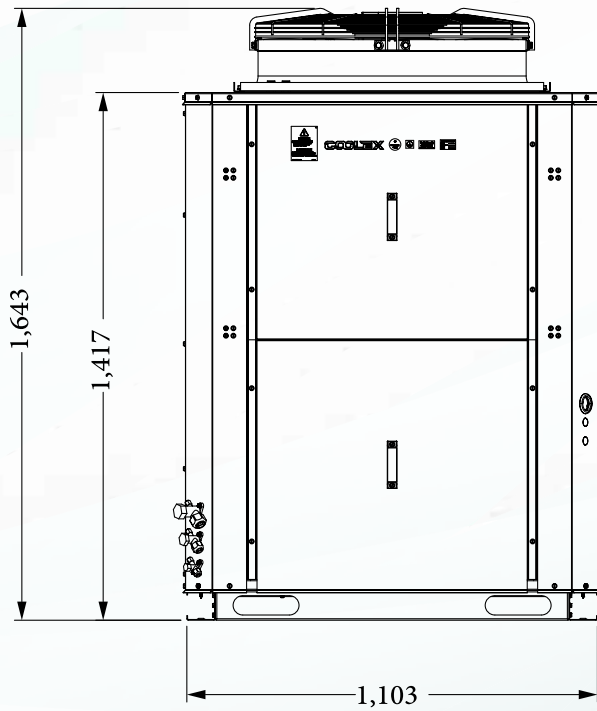

UNIT DIMENSIONS (OUTDOOR UNIT)

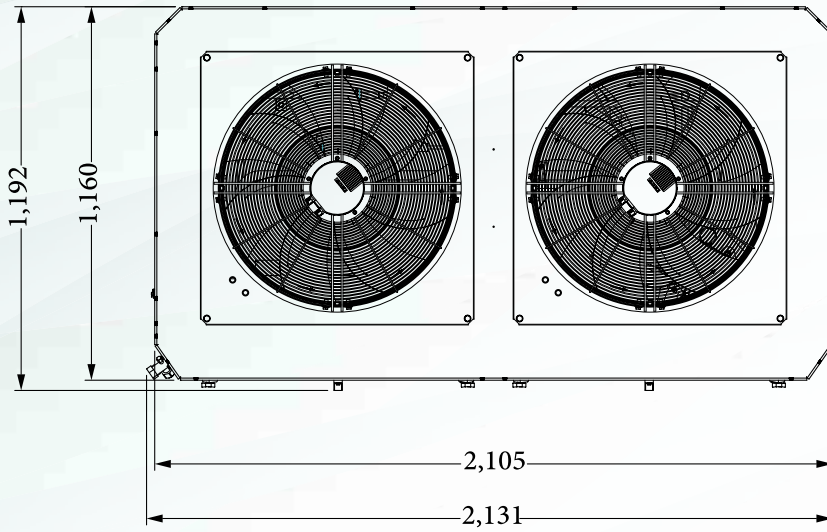

IVCF-01366CDH/
IVCF-01546CDH

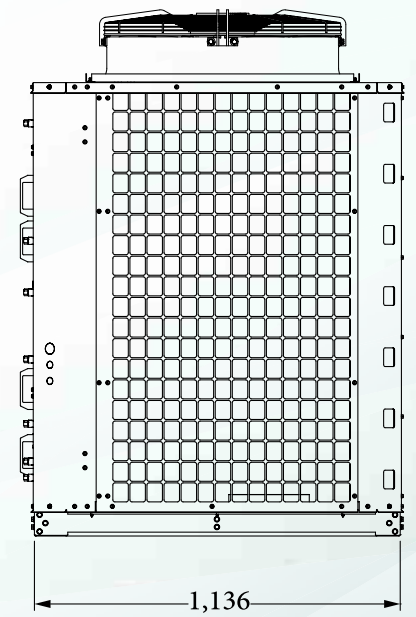
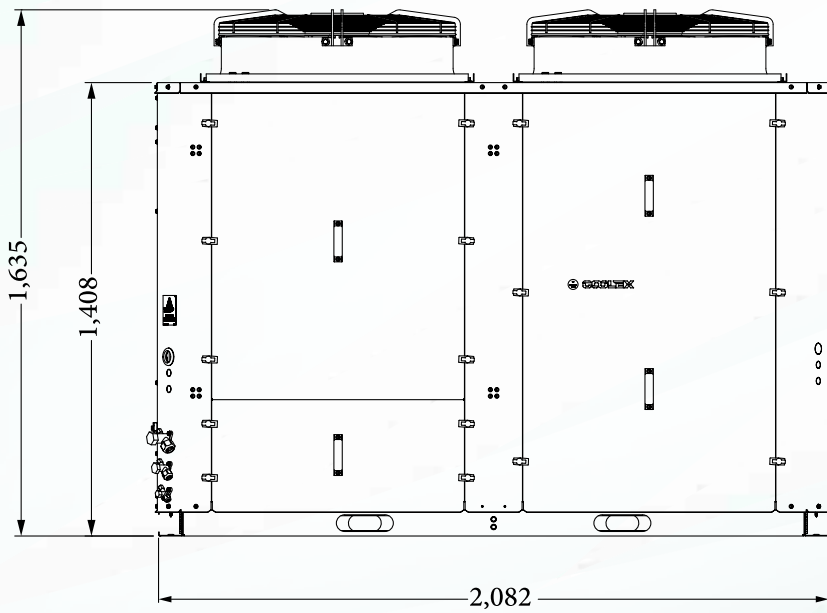

WIRING DIAGRAM (INDOOR UNIT)

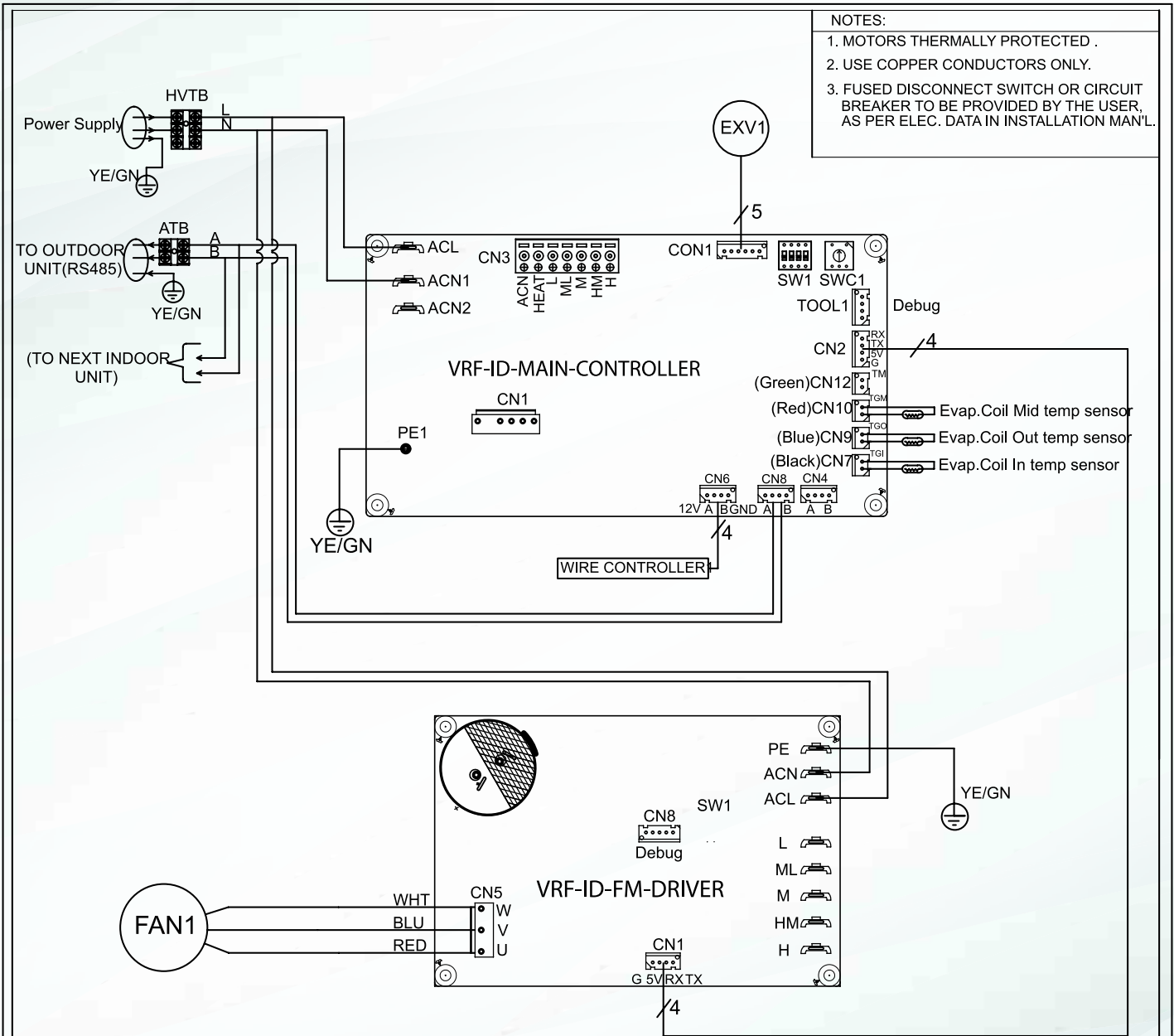

- NOTES:**
1. MOTORS THERMALLY PROTECTED .
 2. USE COPPER CONDUCTORS ONLY.
 3. FUSED DISCONNECT SWITCH OR CIRCUIT BREAKER TO BE PROVIDED BY THE USER, AS PER ELEC. DATA IN INSTALLATION MAN'L.

IDU Capacity select/Dip Switch Setting

SW1_1-SW14	0(OFF),0(OFF),0(OFF),0(OFF)	0(OFF),0(OFF),0(OFF),1(ON)	0(OFF),0(OFF),1(ON),0(OFF)	0(OFF),0(OFF),1(ON),1(ON)	0(OFF),1(ON),0(OFF),0(OFF)	0(OFF),1(ON),0(OFF),1(ON)	0(OFF),1(ON),1(ON),0(OFF)
IDU Capacity	18K	24K	30K	36K	42K	48K	60K

FAULT CODE/ PROTECTION CODE EXX:

E00 - INDOOR AMBIENT TEMP. SENSOR FAILURE(WIRED CONTROLLER)
 E01 - INDOOR EVAPORATOR SENSOR FAILURE
 E05 - COMMUNICATION FAULT,MAIN CONTROLLER AND WIRE THERMOSTAT
 E06 - COMMUNICATION FAULT,MAIN CONTROLLER AND DC FAN BOARD
 E35 - COMMUNICATION FAULT,IDU CONTROLLER AND ODU CONTROLLER

WIRING DIAGRAM (OUTDOOR UNIT)

**IVCF-00866CDH/
IVCF-00956CDH/
IVCF-01146CDH**

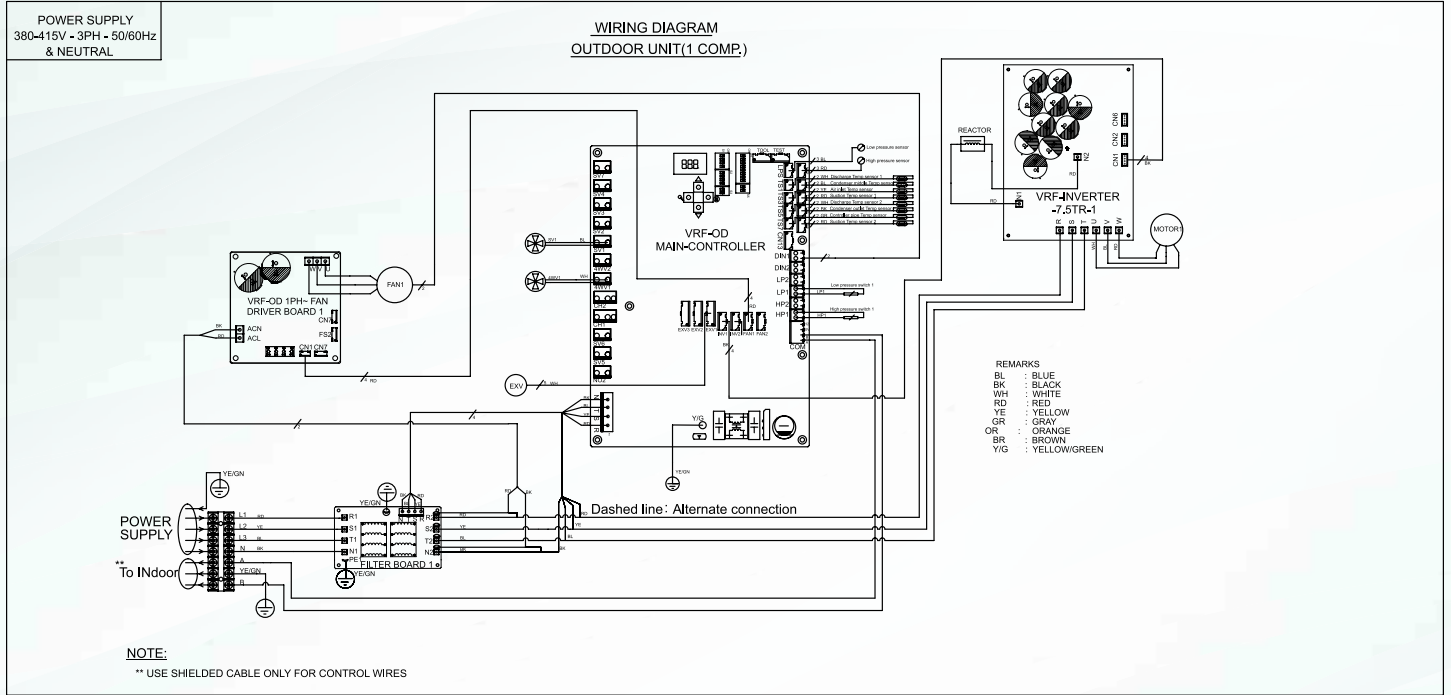

FAULT DETAILS		FAULT DETAILS		DIP SWITCH											
DISPLAY	FAULT DETAILS	DISPLAY	FAULT DETAILS	NO.	Switch	Form	Function	Position				Setting content			
								1	2	3	4	5	6	7	8
E02	OUTDOOR CONDENSER SENSOR FAILURE	E37	OUTDOOR SUCTION SENSOR FAILURE	1	S1	4P	Capacity Setting	1	0	0	0				86K
E03	OUTDOOR AMBIENT TEMP. SENSOR FAILURE	E38	HIGH PRESSURE SENSOR FAILURE					0	1	0	0				95K
E04	COMPRESSOR EXHAUST SENSOR FAILURE	E39	LOW PRESSURE SENSOR FAILURE					0	0	1	0				114K
E06	COMMUNICATION FAULT, MAIN CONTROLLER AND DC FAN BOARD	E40	INDOOR MACHINE NUMBER NOT MATCH					other							
E07	PHASE FAULT	E41	INDOOR CAPACITY NOT MATCH	2	S2	4P	Number of inside units	0	0	0	0				1
E08	COMMUNICATION FAULT, MAIN CONTROLLER AND DRIVER BOARD	E42	REFRIGERANT COOLING PIPE SENSOR FAILURE					0	0	1	0				3
E09	DC OVER VOLTAGE	E43	OUTDOOR CONDENSER OULET SENSOR FAILURE					0	0	1	1				4
E10	DC UNDER BUS VOLTAGE	P00	COMPRESSOR HIGH PRESSURE PROTECTION					0	1	0	0				5
E11	COMPRESSOR SOFT CURRENT	P01	COMPRESSOR LOW PRESSURE PROTECTION					0	1	0	1				6
E12	COMPRESSOR HARD CURRENT	P02	INDOOR FAN MOTOR PROTECTION					0	1	0	0				7
E13	COMPRESSOR PHASE LOSS	P03	COMPRESSOR OVERLOAD PROTECTION					0	1	0	1				8
E14	NO COMPRESSOR	P04	DEHUMIDIFICATION ERROR / INDOOR ANTI FREEZE ERROR					0	1	1	0				9
E15	AD NOISE/OFFSET ERROR	P05	HEATING MODE CONDENSER OVERHEAT PROTECTION					0	1	1	1				10
E16	SOFTWARE WATCHDOG RESET	P06	OUTDOOR AMBIENT TEMP. OVER PROTECTION					1	0	0	0				11
E17	COMPRESSOR STALL	P07	MACHINE POWER SUPPLY OVER VOLTAGE PROTECTION					1	0	0	1				12
E18	UNDEFINED INTERRUPT FAILURE	P08	COMPRESSOR DISCHARGE TEMPERATURE PROTECTION					1	0	1	0				13
E19	HARDWARE WATCHDOG	P09	COMPRESSOR OVERCURRENT PROTECTION					1	0	1	1				14
E20	DC VOLTAGE MUTATION	P10	OUTDOOR COIL TEMPERATURE OVER PROTECTION					1	1	0	0				15
E21	SPEED ESTIMATION ERROR OR CONTROL EXCEPTION	P11	IPM PROTECTION					1	1	0	1				16
E22	D-AXIS OR Q-AXIS CURRENT CONTROL ERROR	P12	DC BUS OVER VOLTAGE (DETECTED BY MAIN BOARD)					1	1	1	0				...
E23	INVERTER PWM OR PFC PWM, INITIALIZATION ERROR	P13	DC BUS UNDER VOLTAGE (DETECTED BY MAIN BOARD)					1	1	1	1				...
E24	AC PEAK OVER CURRENT	P14	SYSTEM PRESSURE TOO HIGH	3	S4	8P	Functional selection
E25	DC BUS OVER VOLTAGE	P15	SYSTEM PRESSURE TOO LOW												0:Phase sequence ON 1:Phase sequence OFF
E26	AC OVER VOLTAGE	P16	REFRIGERANT COOLING PIPE TEMPERATURE ABNORMAL												
E27	AC UNDER VOLTAGE	P17	MACHINE POWER SUPPLY VOLTAGE ABNORMAL												
E28	AC ZERO CROSSING DETECTION FAULT	P18	HIGH PRESSURE UNDER PROTECTION												
E29	OVER POWER FAILURE	P19	COMPRESSION RATIO ABNORMAL												
E34	Outdoor DC fan error	P20	OUTFAN IPM TEMPERATURE HIGH PROTECTION												
E35	COMMUNICATION FAULT, IDU CONTROLLER AND ODU CONTROLLER	P21	HIGH PRESSURE OVER PROTECTION												

CAUTION

DUE TO HIGH VOLTAGE, DO NOT TOUCH THE TERMINALS IN THE CONTROL BOARD DURING OPERATION AND 5 MINUTES AFTER SWITCHING OFF. NEXT, CONFIRM THE VOLTAGE RECTIFICATION CIRCUIT BETWEEN DIODE BRIDGE (+) AND (-) HAS DROPPED TO BELOW 42V, BEFORE ACCESSING TO THE TERMINALS IN THE CONTROL BOARD.

WIRING DIAGRAM (OUTDOOR UNIT)

IVCF-01366CDH/
IVCF-01546CDH

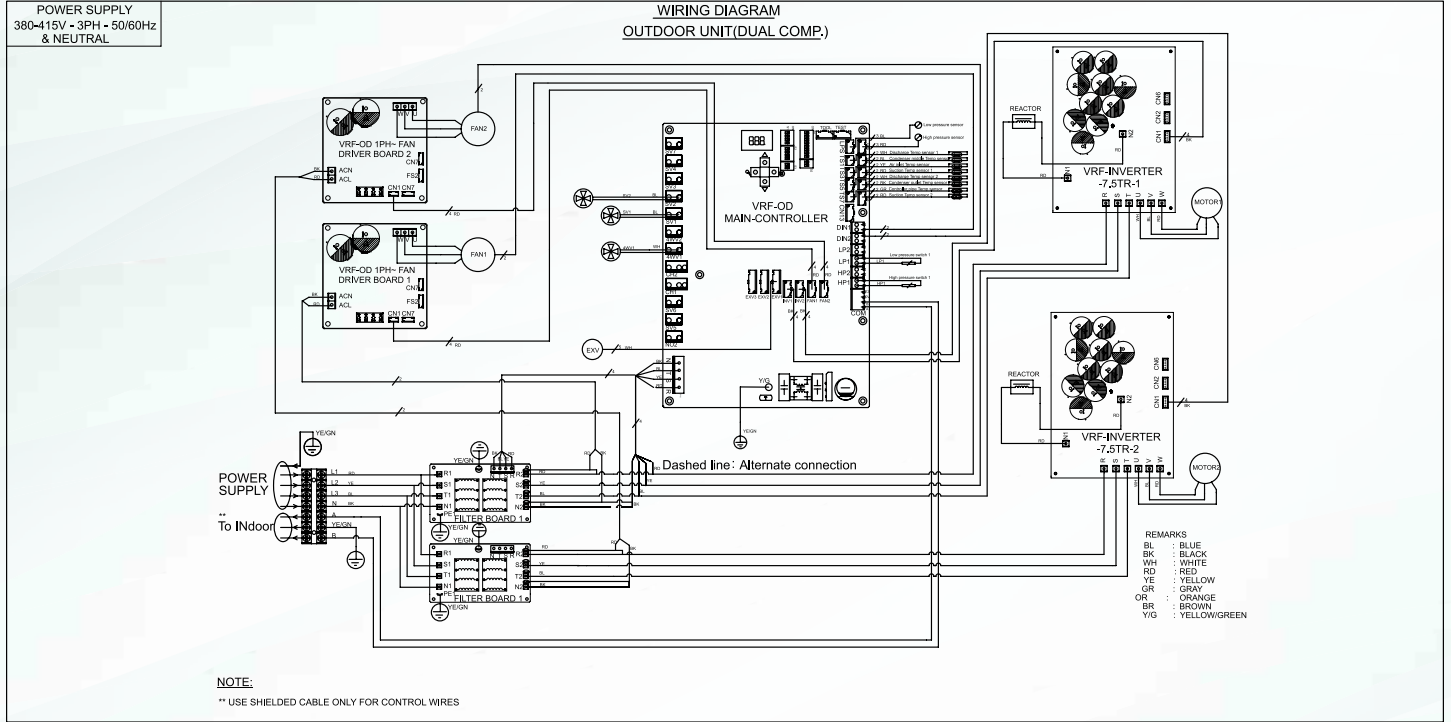

REFL#	FAULT DETAILS	REFL#	FAULT DETAILS
E02	OUTDOOR CONDENSER SENSOR FAILURE	E37	OUTDOOR SUCTION SENSOR FAILURE
E03	OUTDOOR AMBIENT TEMP. SENSOR FAILURE	E38	HIGH PRESSURE SENSOR FAILURE
E04	COMPRESSOR EXHAUST SENSOR FAILURE	E39	LOW PRESSURE SENSOR FAILURE
E06	COMMUNICATION FAULT, MAIN CONTROLLER AND DC FAN BOARD	E40	INDOOR MACHINE NUMBER NOT MATCH
E07	PHASE FAULT	E41	INDOOR CAPACITY NOT MATCH
E08	COMMUNICATION FAULT, MAIN CONTROLLER AND DRIVER BOARD	E42	REFRIGERANT COOLING PIPE SENSOR FAILURE
E09	DC OVER VOLTAGE	E43	OUTDOOR CONDENSER OULET SENSOR FAILURE
E10	DC UNDER BUS VOLTAGE	P00	COMPRESOR HIGH PRESSURE PROTECTION
E11	COMPRESSOR SOFT CURRENT	P01	COMPRESOR LOW PRESSURE PROTECTION
E12	COMPRESSOR HARD CURRENT	P02	INDOOR FAN MOTOR PROTECTION
E13	COMPRESSOR PHASE LOSS	P03	COMPRESSOR OVERLOAD PROTECTION
E14	NO COMPRESSOR	P04	DEHUMIDIFICATION ERROR / INDOOR ANTI FREEZE ERROR
E15	AD NOISE/OFFSET ERROR	P05	HEATING MODE CONDENSER OVERHEAT PROTECTION
E16	SOFTWARE WATCHDOG RESET	P06	OUTDOOR AMBIENT TEMP. OVER PROTECTION
E17	COMPRESSOR STALL	P07	MACHINE POWER SUPPLY OVER VOLTAGE PROTECTION
E18	UNDEFINED INTERRUPT FAILURE	P08	COMPRESSOR DISCHARGE TEMPERATURE PROTECTION
E19	HARDWARE WATCHDOG	P09	COMPRESSOR OVERCURRENT PROTECTION
E20	DC VOLTAGE MUTATION	P10	OUTDOOR COIL TEMPERATURE OVER PROTECTION
E21	SPEED ESTIMATION ERROR OR CONTROL EXCEPTION	P11	IPM PROTECTION
E22	D-AXIS OR Q-AXIS CURRENT CONTROL ERROR	P12	DC BUS OVER VOLTAGE (DETECTED BY MAIN BOARD)
E23	INVERTER PWM OR PFC PWM, INITIALIZATION ERROR	P13	DC BUS UNDER VOLTAGE (DETECTED BY MAIN BOARD)
E24	AC PEAK OVER CURRENT	P14	SYSTEM PRESSURE TOO HIGH
E25	DC BUS OVER VOLTAGE	P15	SYSTEM PRESSURE TOO LOW
E26	AC OVER VOLTAGE	P16	REFRIGERANT COOLING PIPE TEMPERATURE ABNORMAL
E27	AC UNDER VOLTAGE	P17	MACHINE POWER SUPPLY VOLTAGE ABNORMAL
E28	AC ZERO CROSSING DETECTION FAULT	P18	HIGH PRESSURE UNDER PROTECTION
E29	OVER POWER FAILURE	P19	COMPRESSION RATIO ABNORMAL
E34	OUTDOOR DC FAN ERROR	P20	OUTFAN IPM TEMPERATURE HIGH PROTECTION
E35	COMMUNICATION FAULT, IDU CONTROLLER AND ODU CONTROLLER	P21	HIGH PRESSURE OVER PROTECTION

DIP SWITCH													
NO.	Switch	Form	Function	Position								Setting content	
				1	2	3	4	5	6	7	8		
1	S1	4P	Capacity Setting	1	0	0	1						136K
				0	1	0	1						154K
				other									
2	S2	4P	Number of inside units	0	0	0	0						1
				0	0	0	1						2
				0	0	1	0						3
				0	0	1	1						4
				0	1	0	0						5
				0	1	0	1						6
				0	1	1	0						7
				0	1	1	1						8
				1	0	0	0						9
				1	0	0	1						10
				1	0	1	0				11		
				1	0	1	1				12		
				1	1	0	0				13		
				1	1	0	1				14		
				1	1	1	0				15		
				1	1	1	1				16		
3	S4	8P	Functional selection	
				0								0:Phase sequence ON 1:Phase sequence OFF	

CAUTION

DUE TO HIGH VOLTAGE, DO NOT TOUCH THE TERMINALS IN THE CONTROL BOARD DURING OPERATION AND 5 MINUTES AFTER SWITCHING OFF. NEXT, CONFIRM THE VOLTAGE RECTIFICATION CIRCUIT BETWEEN DIODE BRIDGE (+) AND (-) HAS DROPPED TO BELOW 42V, BEFORE ACCESSING TO THE TERMINALS IN THE CONTROL BOARD.





شركة صناعات التبريد والتخزين والخدمات النفطية

Refrigeration Industries & Storage and Oil Services Co. KSC



Ref no.: CVRFF 26-4-000

CONTACT US



T : +965 183 33 80

w : www.coolex.com.kw

**Sulaibiya Industrial, Block 1,
Road 4, Plot No. 105.**