

Commercial Tapware



GUARDIAN[®] TAPWARE

Gooseneck Bench Mounted Sensor Tap

- T-3MSS-GHMST21B
- T-3MSS-GHMST21M
- T-3MSS-GHMST21B-TV
- T-3MSS-GHMST21M-TV

Available in mains or battery powered, with optional tempering valve

- Battery Powered – 2x CR123 3V Lithium Batteries Estimates 80,000 Cycles
- Mains Powered – 6V Transformer
- Full S/S Construction
- Sensor Range Nominal: 50mm – 200mm
- Maximum Run Time: 60 Seconds
- WELS 6 Star 3.5LPM
- Working Pressure Range 150kPa-500kPa
- Maximum Operating Temperature 50 Degrees

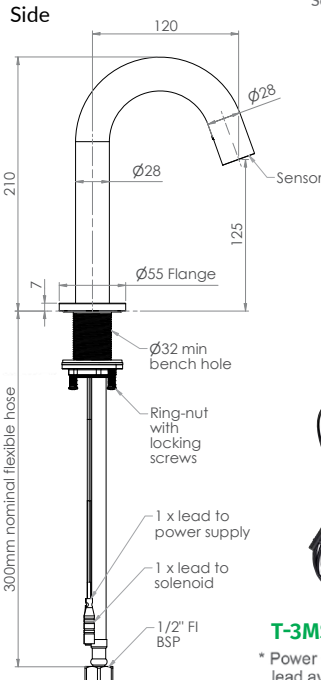
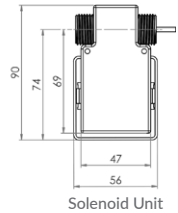
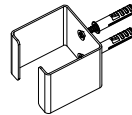
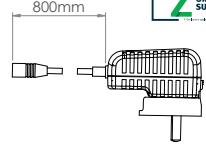
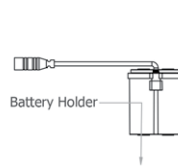

T-3MSSP-HMST-3M
* Power Supply with 3 metre lead available separately



*Exclusions apply

3monkeez.com.au