

**HITACHI**  
Inspire the Next

<http://www.hitachi.com/businesses/elevator/index.html>

Contact Address:

The information in this catalogue is subject to change without notice.



# MACHINE ROOM-LESS ELEVATOR

Model UAG Series SN1



# Creating a New History

Hitachi Group is active in a wide range of business sectors. From the technology and experience built up over many years, come the synergies that feed new innovation.

Hitachi has been developing and manufacturing elevators and escalators since 1924.

As social demands on elevators change over time, Hitachi's machine room-less elevator model UAG series SN1, developed in Japan, meets the needs of customers in terms of efficiency, safety, comfort, and space savings. Hitachi is creating a new history for elevators, and for your building.



## History of Hitachi elevators

•**1932**•First elevator is delivered: freight elevator for Tokyo Electric Co. •**1968**•300m/min. elevator is delivered to Japan's first skyscraper: Kasumigaseki Building. •**1991**•Power-saving inverter-controlled ultra-high-speed elevator commences operations: Tokyo Metropolitan Government Building No. 1. •**2003**•300m/min. double-deck elevator is delivered: Roppongi Hills Mori Tower, Tokyo. •**2007**•480m/min, 2,850 kg high-rise shuttle elevator is delivered: Tokyo Midtown, Midtown Tower. •**2008**•World's largest ultra-high-speed double-deck elevator is delivered: Shanghai World Financial Center. •**2011**•600m/min. ultra-high-speed elevator for the Middle East: Al Hamra Mixed-Use Complex, Kuwait. •**2012**•High-speed, large-capacity elevator providing access to Japan's highest (450m) observation platform: Tokyo Sky Tree. •**2016**•Delivery of the ultra-high-speed elevators, with a speed of 1,200 m/min. (20 m/s), to the Guangzhou CTF Finance Centre (530m tall) in Guangzhou, China.

## Simplified specification selection process

Create the elevator that best meets your needs by selecting specifications and design options from this catalogue.

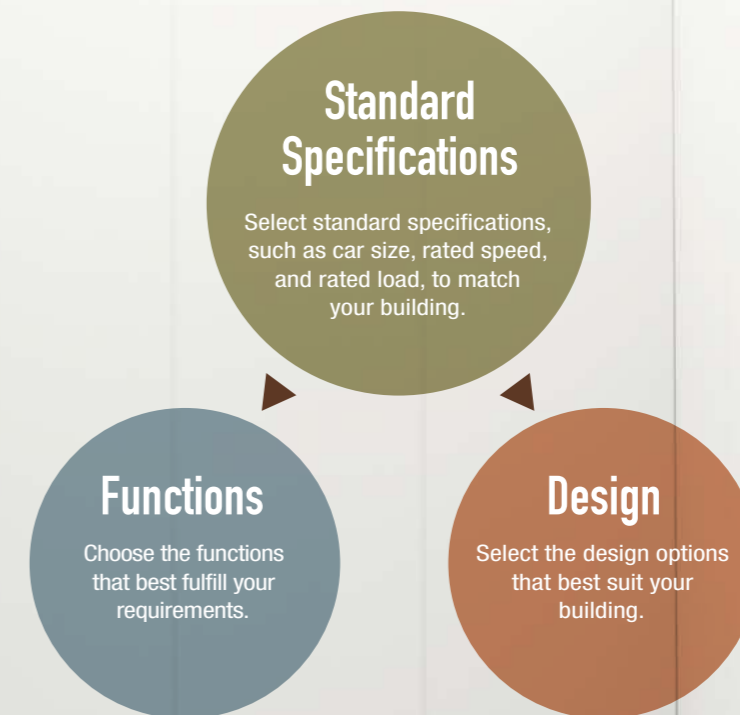

# Four classifications of value we provide for your building

## Energy efficiency

Page 5, 6

**Reduced energy consumption with standard specifications**  
Power consumption can be reduced to approximately 1/6.

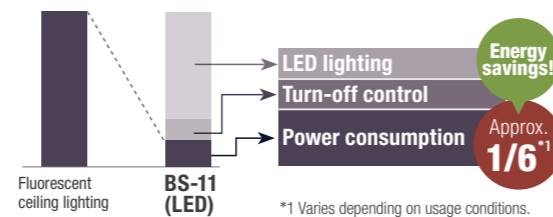

### LED lighting

Use of LED lighting gives reduction in energy consumption by approximately 1/4 and its service life three times longer compared with fluorescent lighting.

### Automatic turn-off of car lighting and fan

Standard

When the elevator is idle, the lighting and ventilation fan in the elevator are automatically turned off to conserve energy. Energy consumption is reduced by adopting LED lighting for the ceiling and shortening the time until the lighting and fan turn off.

### Regenerative system

Option

The traction mechanism acts as a power generator and transmit power back to the building electrical network that reduces energy consumption by approximately 30%.



\*2 Effectiveness during normal operation. Effectiveness differs depending on usage conditions.

## Comfort

Page 7

### Improved riding comfort

Standard

Motor control and vibration-absorbing type guide shoes provide a quiet and smooth ride.

### Ion generator

Option

Ion generator works to improve air quality.

### Elevator interior deodorizing test\*3

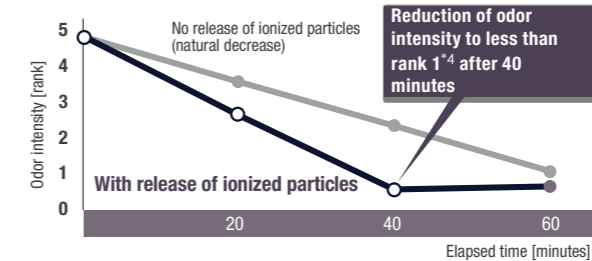

\*3 Results after 40 minutes in test performed in (13-passenger) elevator measuring approx. 5.5 m<sup>3</sup>. Results may differ from those in actual usage space.  
\*4 Odor strength rank 1 is defined as "extremely weak odor that is hardly noticeable."



Note: Testing organization: Hitachi Power Solutions Co., Ltd. Testing method: Verification using six-rank odor intensity indication method in passenger elevator with 13-person capacity Deodorizing method: Release of ionized particles Subject: Methyl mercaptan was released and the change in its concentration was measured.

## Safety & Emergency

Page 8

### Door signal with multi-beam door sensor

Option

Door signal that tells when the door is going to close for enhanced safety.

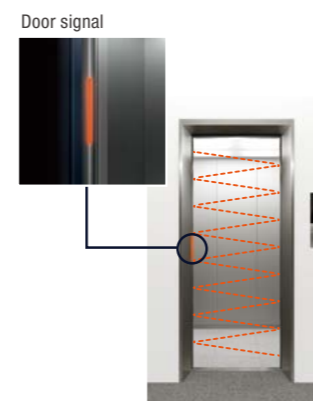

### Micro-leveling

Standard

Automatically corrects the elevator landing level when there is a level difference between car and floor.

### Automatic rescue device for power failure

Option

When a power failure is detected, the drive power supply switches over to battery power, and the elevator automatically moves to the nearest floor and releases the passengers.

## Design

Page 9, 10

### LCD indicators

Option

In-car indicator and hall indicator with color LCD are available. They provide a quick overview of the operating status.



### Car and hall design

Select the most suitable design from the options available, including ceiling and 3 side wall designs created by Hitachi's designers to match a variety of building types.



# Energy efficiency

## LED lighting

By adopting LED lighting for all ceiling designs, energy consumption is reduced and service life is prolonged compared with fluorescent lighting.

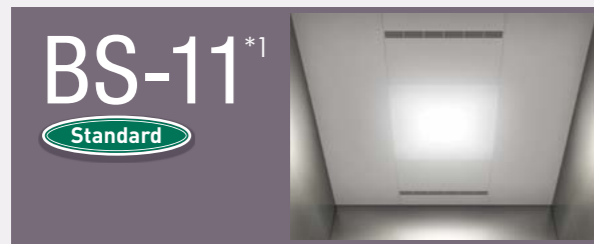

**Power consumption approx. 1/4** that of fluorescent lighting  
Employs LED lighting with **approx. 3x<sup>2</sup> longer service life.**

	Fluorescent ceiling lighting	BS-11 (LED)
Power consumption	69 W	17 W <sup>3</sup>
Service life	Approx. 12,000 hours	Approx. 40,000 hours <sup>4</sup>

By changing the time until the lighting turns off during standby from three to one minute...

**Power consumption can be reduced to approx. 1/6.**

	Fluorescent ceiling lighting	BS-11 (LED)
Annual illumination duration	Approx. 3,000 hours	Approx. 1,500 hours <sup>5</sup>
Annual power consumption	Approx. 207 kWh/year	Approx. 35 kWh/year

### •Reduction of power consumption

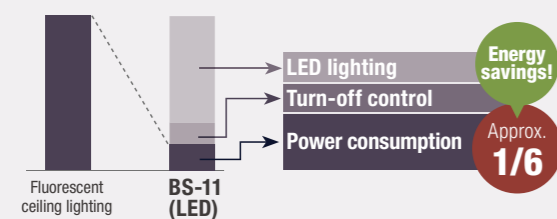

**Power consumption approx. 1/6** that of fluorescent lighting  
Employs LED lighting with **approx. 3x<sup>2</sup> longer service life.**

	Fluorescent ceiling lighting	SL-11 (LED)
Power consumption	207 W	33 W <sup>3</sup>
Service life	Approx. 12,000 hours	Approx. 40,000 hours <sup>4</sup>

By changing the time until the lighting turns off during standby from three to one minute...

**Power consumption can be reduced to approx. 1/12.**

	Fluorescent ceiling lighting	SL-11 (LED)
Annual illumination duration	Approx. 3,000 hours	Approx. 1,500 hours <sup>5</sup>
Annual power consumption	Approx. 621 kWh/year	Approx. 50 kWh/year

### •Reduction of power consumption

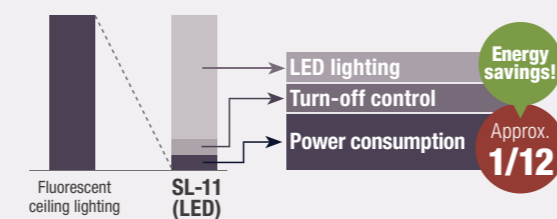

\*1 These ceilings are not compliant with EN81-20/50, but they can be used if the customer agrees.  
\*2 Comparison with 10-passenger model with fluorescent ceiling lighting. Results may differ depending on ceiling configuration and dimensions.  
\*3 Power consumption of fixture including lighting power supply.  
\*4 Rated service life of fixture including lighting power supply. Actual service life may vary depending on usage conditions.  
\*5 Varies depending on usage conditions.

## Automatic turn-off of car lighting and fan

Standard

When the elevator is idle, the lighting and ventilation fan in the elevator are automatically turned off to conserve energy. Energy consumption is reduced by adopting LED lighting for the ceiling and shortening the time until the lighting and fan turn off.

## Regenerative system

Option

### Making use of energy generated by the elevator

Making use of the energy generated by the elevator when traveling downwards with a heavy car load or upwards with a light car load, the traction mechanism acts as a power generator and transmit power back to the electrical network in the building.

#### Flow of regenerated power

••• Industrial power  
— Regenerated power

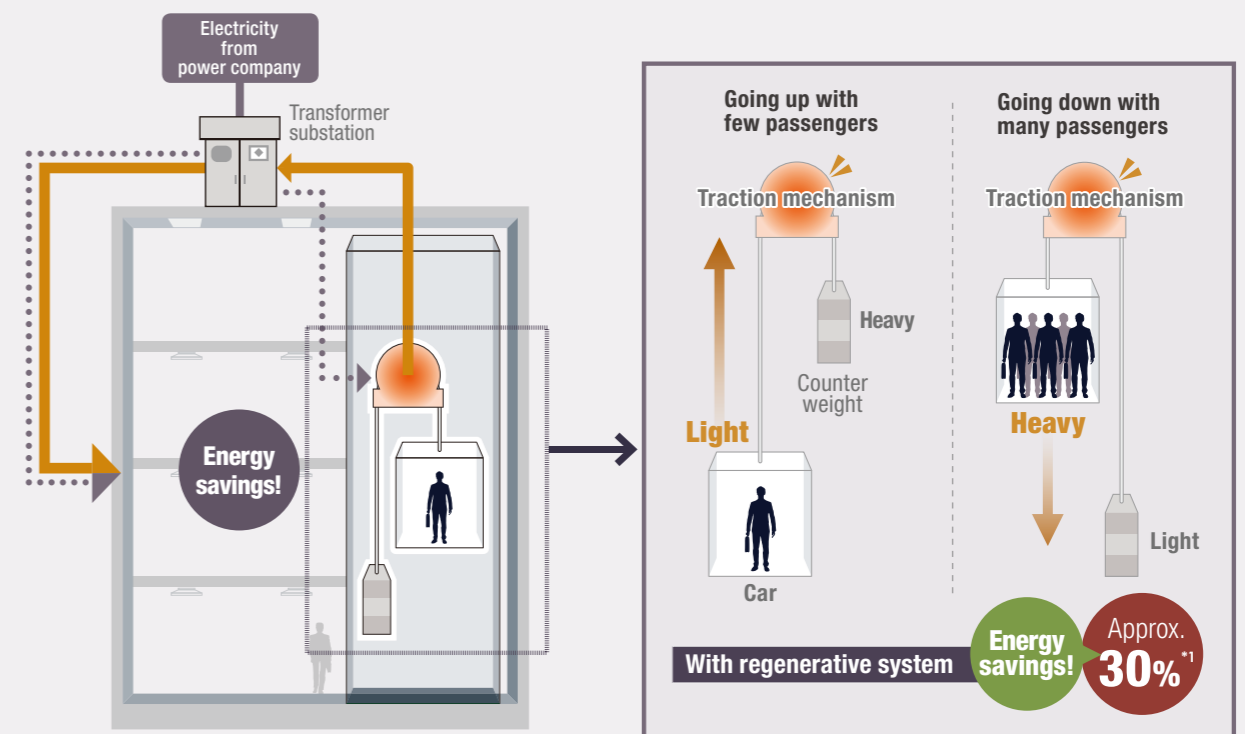

\*1 Effectiveness during normal operation and differs depending on usage conditions.

# Comfort

## Ion generator

Option



Note: Artist's conception.

### Ion generator improves air quality

An ion generator manufactured in Japan is mounted on top of the car. Nano-sized electrostatic atomized water particles work to improve air quality.

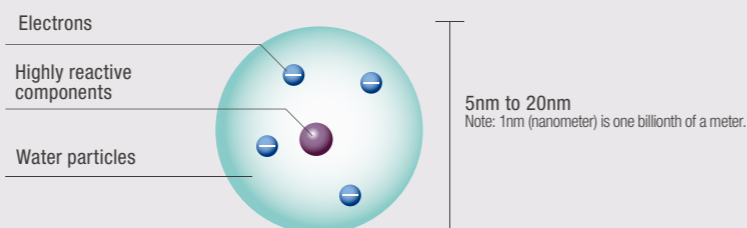

### Elevator interior deodorizing test<sup>\*1</sup>

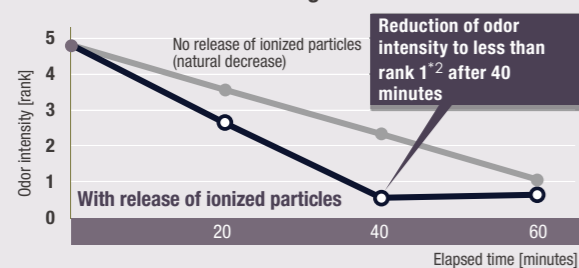

\*1 Results after 40 minutes in test performed in (13-passenger) elevator measuring approx. 5.5 m<sup>3</sup>. Results may differ from those in actual usage space.  
\*2 Odor strength rank 1 is defined as "extremely weak odor that is hardly noticeable."

Testing organization: Hitachi Power Solutions Co., Ltd.  
Testing method: Verification using six-rank odor intensity indication method in passenger elevator with 13-person capacity  
Deodorizing method: Release of ionized particles  
Subject: Methyl mercaptan was released and the change in its concentration was measured.

### About ionized particles

The ionized particles released into the air come into contact with odor molecules and the OH radicals break down substances that cause odor.<sup>1</sup> Also, the ionized particles come into contact with allergens (pollen<sup>2</sup> and mites<sup>3</sup>), bacteria,<sup>4</sup> and viruses,<sup>5</sup> and the OH radicals denaturize their protein and suppress them.

1. Testing organization: Panasonic Corporation Product Analysis Center. Testing method: Direct exposure in 250-liter test space and verification using six-rank odor intensity indication method. Deodorizing method: Release of ionized particles. Subject: Accumulated cigarette odor. Test result: Odor intensity reduction of 0.8 after 30 minutes. Test number: E02-090313MH-01 2. Testing organization: Panasonic Corporation Product Analysis Center. Testing method: Direct exposure in 45-liter test space and measurement using ELISA method. Suppression method: Release of ionized particles. Subject: Allergen (pollen). Test result: Over 99% suppression after two hours. Test number: E02-080303IN-03 3. Testing organization: Panasonic Corporation Product Analysis Center. Testing method: Direct exposure in 45-liter test space and measurement using ELISA method. Suppression method: Release of ionized particles. Subject: Allergen (mites). Test result: Over 98% suppression after two hours. Test number: E02-080204IN-02 4. Testing organization: Kitasato Research Center for Environmental Science. Testing method: Direct exposure in 1-square-meter test vessel and measurement of bacteria count. Suppression method: Release of ionized particles. Subject: Airborne bacteria. Test result: Over 99% suppression after 20 minutes. Kitasato Biogenetic: 20\_0154\_1. Test performed for one type of bacteria only. 5. Testing organization: Kitasato Research Center for Environmental Science. Testing method: Direct exposure in 1-square-meter test vessel and measurement of virus count. Suppression method: Release of ionized particles. Subject: Airborne virus. Test result: Over 99% suppression after 90 minutes. Kitasato Biogenetic: 20\_0154\_1. Test performed for one type of virus only.

Note: The ionized particles suppress viruses, etc., but they are not guaranteed to prevent infection.  
Note: The ion generator is not available in the following cases:  
(1) When the ceiling is supplied by the customer.  
(2) When the car internal depth is 1,250mm or less.

## Improved riding comfort

Standard

Measures such as control to suppress motor vibration and vibration-absorbing type guide shoes are utilized. These reduce noise and vibration when the elevator is in motion for a smooth and quiet ride.

# Safety & Emergency

## Door signal with multi-beam door sensor (The closing door alert)

Option

### The door signal flashes to notify passengers when the door is starting to close

The multi-beam door sensor is backed by a door signal that notifies passengers when the door is going to close. The LED on the edge of the door starts to blink about one second before the door starts to close. If the door close button in the elevator car is pressed, the LED starts blinking at the same time as the door starts to close.

Door signal



Note: Illustration shows simulated view of beams.

## Micro-leveling

Standard

Automatic correction of elevator landing level when there is a level difference between car and floor. This improves safety when getting on and off the elevator.

## Automatic rescue device for power failure

Option

### In a power failure, the elevator switches to battery operation, and moves to the nearest floor

When a power failure is detected, the drive power supply switches over to battery power, and the elevator automatically moves to the nearest floor and releases the passengers for safety. This lessens the worry of being shut in the elevator by a power outage in a building with no private generator equipment.

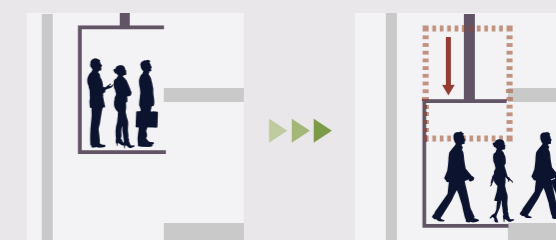

## Ceiling designs (Silkscreen print)

Option

By applying silk screening to the ceilings of SL-11 and DX-101, Hitachi ceiling designs coordinate your elevator with the building decor.

### SL-11\*1



SL-11-Oriental mosaic

SL-11-Cube

SL-11-Kaleidoscope

### DX-101\*1



DX-101-Lattice

DX-101-Geometric star

DX-101-Arabesque

\*1 These ceilings are not compliant with EN81-20/50, but they can be used if the customer agrees.

## Button designs

A wide range of buttons harmonizes with various building designs.

### High-contrast plastic buttons

Standard

High-contrast and raised characters make numbers more legible. Button surfaces are rounded to make it easier to wipe them clean.



### Stainless steel buttons

Option

Various stainless steel buttons are available.



### Interphone button

Standard

Designed for easy use in an emergency.

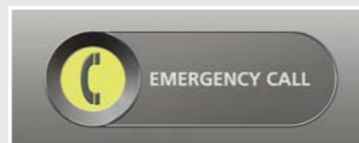

## In-car LCD indicator

Option

### The LCD indicator makes it easy to find necessary information.

An in-car indicator with an 8.4-inch color LCD is available. The LCD with wide angle improves visibility. It displays indications of the operating status, such as earthquake emergency operation, to the user.

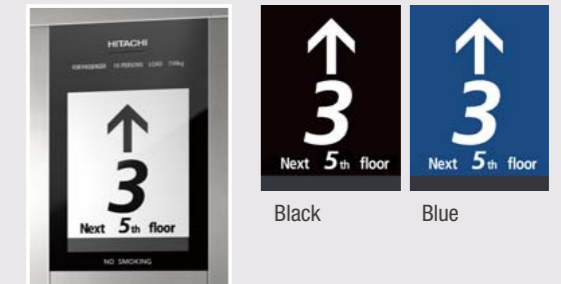

Black

Blue

### Normal

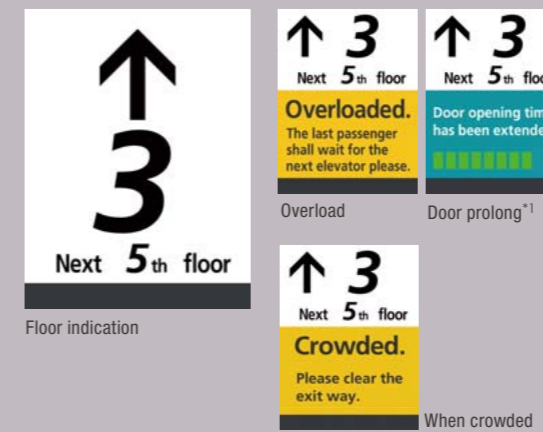

### Emergency



\*1 Display indications regarding operation during earthquakes, etc., require that the corresponding functions be installed.

## Hall LCD indicator

Option

### The hall LCD indicator displays abundant information in the hall.

A hall indicator with a 6.2-inch color LCD is available. Like the in-car LCD indicator, it displays indications of the operating status.



Earthquake\*2

\*2 Display indications regarding operation during earthquakes, etc., require that the corresponding functions be installed.

# Recommended designs

## Car designs

Choose from a wide range of design options to create an elevator look that matches your building.

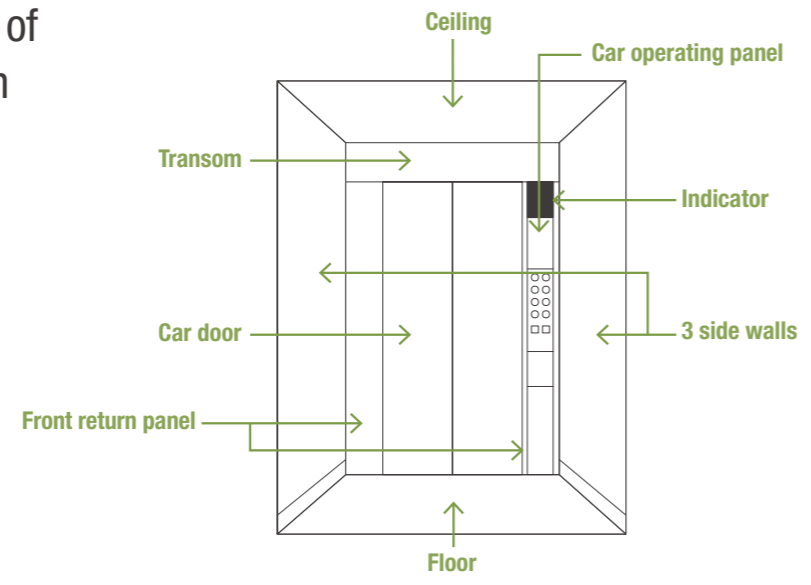

## Recommended designs Samples of designs created by a designer.

Stylish design	Chic design	Simple design
<ul style="list-style-type: none"> <li>Office</li> <li>Commercial building</li> </ul>	<ul style="list-style-type: none"> <li>Residence</li> <li>Hotel</li> </ul>	<ul style="list-style-type: none"> <li>Transport facility</li> <li>Hospital</li> </ul>
<b>Ceiling:</b> SL-series (SL-11-Oriental mosaic)*1 <b>3 side walls:</b> Decorated steel (Craft wood) <b>Car door:</b> Decorated steel (Craft wood)	<b>Ceiling:</b> SL-series (SL-12) <b>3 side walls:</b> Decorated steel (Mocha wood) <b>Car door:</b> Decorated steel (Mocha wood)	<b>Ceiling:</b> Standard (BS-11)*1 <b>3 side walls:</b> Stainless steel hairline <b>Car door:</b> Stainless steel hairline
<b>Ceiling:</b> DX-series (DX-101-Geometric star)*1 <b>3 side walls:</b> Decorated steel (Minamo white) <b>Car door:</b> Decorated steel (Minamo white)	<b>Ceiling:</b> DX-series (DX-11) <b>3 side walls:</b> Laminated plastic sheet (Sandy sakura)*1 <b>Car door:</b> Stainless steel hairline	<b>Ceiling:</b> Standard (BS-11)*1 <b>3 side walls:</b> Decorated steel (Minamo white) <b>Car door:</b> Stainless steel hairline

\*1 These ceilings and LPS are not compliant with EN81-20/50, but they can be used if the customer agrees.

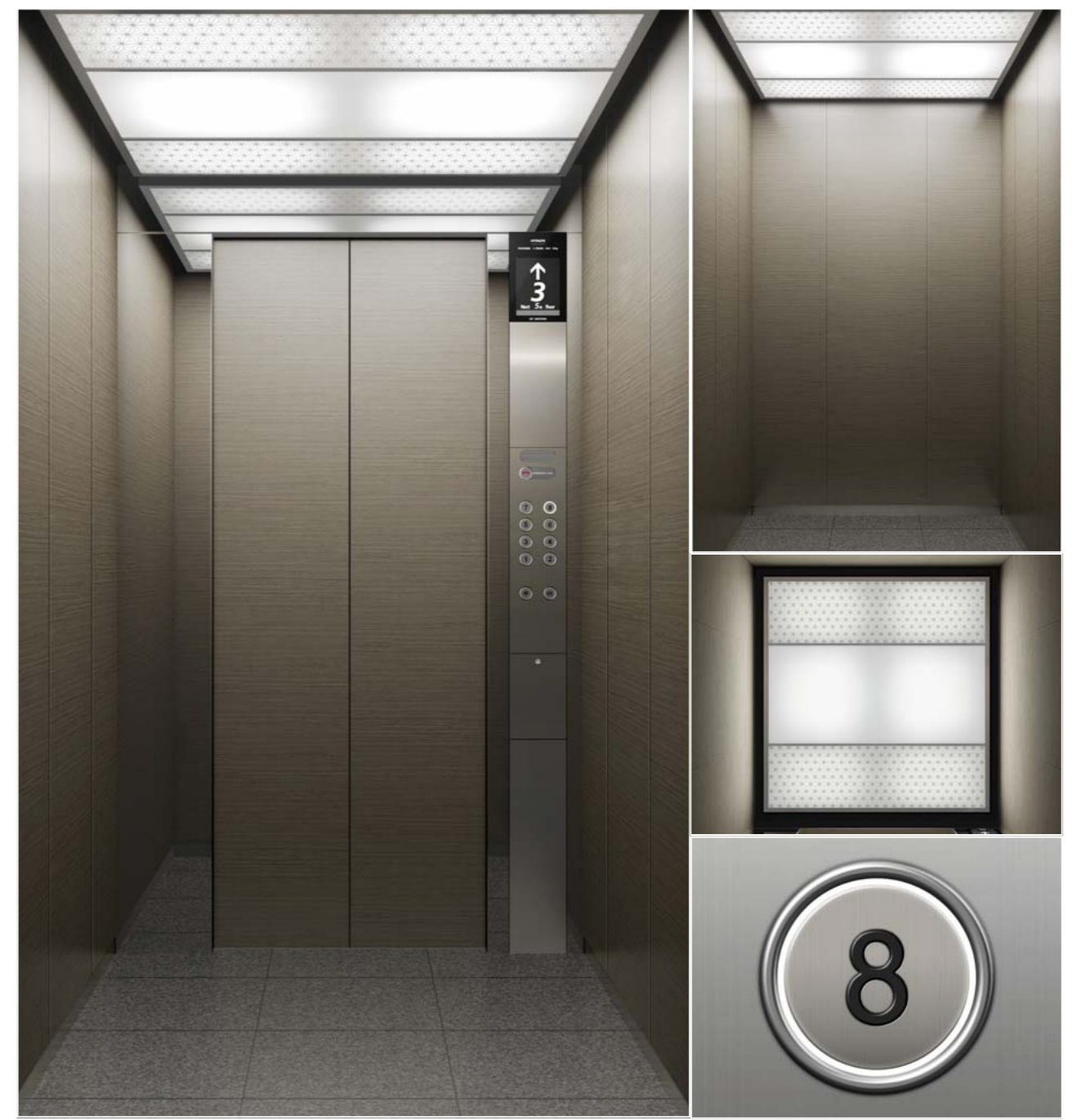

### Stylish design (for office)

Specifications	
<b>Ceiling</b>	SL-series (SL-11-Oriental mosaic)*1
<b>3 side walls</b>	Decorated steel (Craft wood)
<b>Car door</b>	Decorated steel (Craft wood)
<b>Front return panel/Transom</b>	Stainless steel mirror
<b>Floor</b>	Vinyl tile (SA614)*1
<b>Indicator</b>	LCD (8.4 inches)
<b>Car operating panel</b>	Stainless steel Non-directional hairline

\*1 These ceilings and tiles are not compliant with EN81-20/50, but they can be used if the customer agrees.  
 Note: Illustrations show simulated views of elevator interiors. Actual illumination brightness and colors may differ.



**Stylish design (for commercial building)**

Specifications	
<b>Ceiling</b>	DX-series (DX-101-Geometric star)*1
<b>3 side walls</b>	Decorated steel (Minamo white)
<b>Car door</b>	Decorated steel (Minamo white)
<b>Front return panel/Transom</b>	Stainless steel Non-directional hairline
<b>Floor</b>	Vinyl tile (GA204)*1
<b>Indicator</b>	LCD (8.4inches)
<b>Car operating panel</b>	Stainless steel Non-directional hairline

\*1 These ceilings and tiles are not compliant with EN81-20/50, but they can be used if the customer agrees.  
 Note: Illustrations show simulated views of elevator interiors. Actual illumination brightness and colors may differ.



**Chic design (for residential building)**

Specifications	
<b>Ceiling</b>	SL-series (SL-12)
<b>3 side walls</b>	Decorated steel (Mocha wood)
<b>Car door</b>	Decorated steel (Mocha wood)
<b>Front return panel/Transom</b>	Stainless steel Non-directional hairline
<b>Floor</b>	Vinyl tile (GA205)*1
<b>Indicator</b>	LCD (8.4inches)
<b>Car operating panel</b>	Stainless steel Non-directional hairline



**Chic design (for hotel)**

Specifications	
<b>Ceiling</b>	DX-series (DX-11)
<b>3 side walls</b>	Laminated plastic sheet (Sandy sakura)*1
<b>Car door</b>	Stainless steel hairline
<b>Front return panel/Transom</b>	Stainless steel hairline
<b>Floor</b>	Vinyl tile (SA614)*1
<b>Indicator</b>	LCD (8.4 inches)
<b>Car operating panel</b>	Stainless steel hairline

\*1 These tiles and LPS are not compliant with EN81-20/50, but they can be used if the customer agrees.  
 Note: Illustrations show simulated views of elevator interiors. Actual illumination brightness and colors may differ.





### Simple design (for Transport facility)

Specifications	
Ceiling	Standard (BS-11)*1
3 side walls	Stainless steel hairline
Car door	Stainless steel hairline
Front return panel/Transom	Stainless steel hairline
Floor	Vinyl tile (SA614)*1
Indicator	Dot matrix
Car operating panel	Stainless steel hairline

## Hall designs

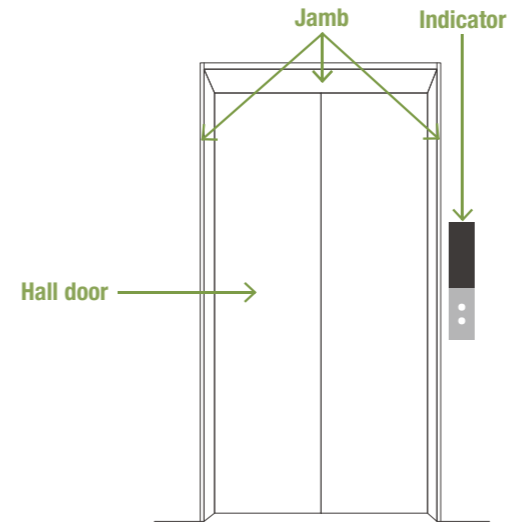

### AS-1X (2PC0) Standard

**Jamb:** Stainless steel hairline  
**Hall door:** Stainless steel hairline  
**Indicator:** Dot-matrix

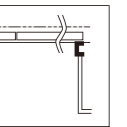

### Simple design (for hospital)

Specifications	
Ceiling	Standard (BS-11)*1
3 side walls	Decorated steel (Minamo white)
Car door	Stainless steel hairline
Front return panel/Transom	Stainless steel hairline
Floor	Vinyl tile (SA 605)*1
Indicator	LCD (8.4inches)
Car operating panel	Stainless steel hairline

\*1 These ceilings and tiles are not compliant with EN81-20/50, but they can be used if the customer agrees.  
 Note: Illustrations show simulated views of elevator interiors. Actual illumination brightness and colors may differ.



### SS-1X (2PC0) Option

**Jamb:** Stainless steel hairline  
**Hall door:** Stainless steel hairline  
**Indicator:** Dot-matrix

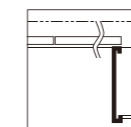

### TS-1X (2PC0) Option

**Jamb:** Stainless steel hairline  
**Hall door:** Stainless steel hairline etching(SD-1038)  
**Indicator:** LCD

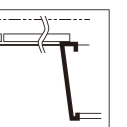

Note: Illustrations show simulated views of elevator interiors. Actual illumination brightness and colors may differ.

# Ceilings and Handrails

## Ceilings

### Standard

Standard

**BS-11**<sup>\*1</sup> **Center:** Milky white acrylic<sup>\*2</sup>  
**Surrounding:** Decorated steel(White)



### Select

Option

**SL-11**<sup>\*1</sup> **Entire surface:** Milky white acrylic  
**Surrounding:** Extruded aluminum

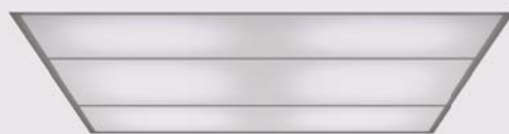

**SL-12**<sup>\*3</sup> **Entire surface:** Painted steel(White)  
**Illumination slits:** Painted steel(Black)  
**Surrounding:** Extruded aluminum

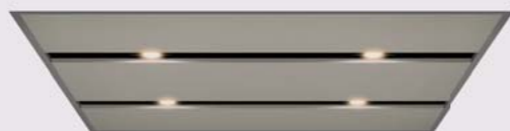

#### Variation of SL-11

##### Silkscreen print

Option

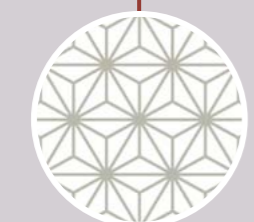
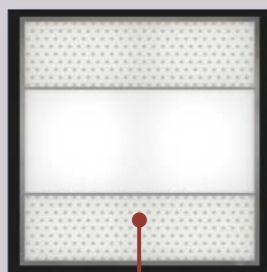

SL-11-Oriental mosaic<sup>\*1</sup>

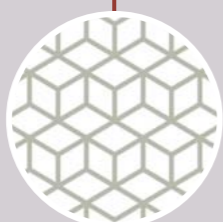

SL-11-Cube<sup>\*1</sup>

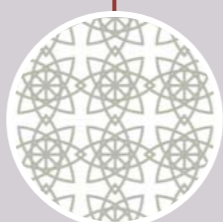
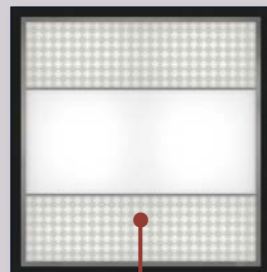

SL-11-Kaleidoscope<sup>\*1</sup>

<sup>\*1</sup> These ceilings are not compliant with EN81-20/50, but they can be used if the customer agrees.  
<sup>\*2</sup> For some car sizes there are two milky white acrylic options.  
Note: It is also possible to use ceiling materials supplied and installed by the customer.  
Note: Depending on applicable regulations, car top emergency trap door may be required.

### Deluxe

Option

**DX-101**<sup>\*1</sup> **Center:** Painted steel(White)  
**Both side:** Milky white acrylic  
**Surrounding:** Extruded aluminum



**DX-11** **Center:** Painted steel(White)/Indirect lighting  
**Both side:** Painted steel(White)/Down light  
**Surrounding:** Extruded aluminum



#### Variation of DX-101

##### Silkscreen print

Option

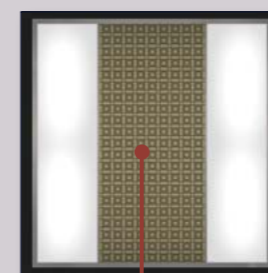

DX-101-Lattice<sup>\*1</sup>

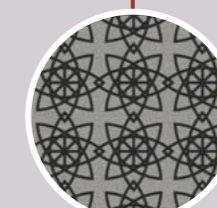
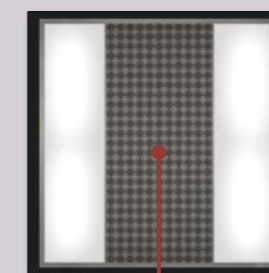

DX-101-Geometric star<sup>\*1</sup>

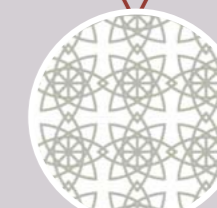
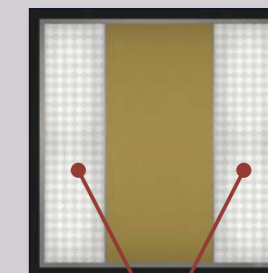

DX-101-Arabesque<sup>\*1</sup>

<sup>\*1</sup> These ceilings are not compliant with EN81-20/50, but they can be used if the customer agrees.  
Note: It is also possible to use ceiling materials supplied and installed by the customer.  
Note: Depending on applicable regulations, car top emergency trap door may be required.

## Handrails

Option



Round pipe type (stainless steel hairline) Diameter: 32mm



Flat type (Aluminum) Width: 90mm<sup>\*1</sup>



Flat type (stainless steel hairline) Width: 50mm

<sup>\*1</sup> Bed type : 2-line flat handrail (Aluminum) (width: 90mm) is standard.

Note: Illustrations show simulated views of handrail designs. Actual illumination brightness and colors may differ.

# Operating panels and indicators

## Car operating panels

**Stainless steel cover plate**

**Indicator type (dot-matrix)** **Standard**

**Indicator type (LCD)** **Option**

**Car position indicators (LCD)** **Option**

In addition to the standard white, you can select black or blue as the background color.

White (standard color) Black Blue

**Horizontal operating panels** **Option**

**Stainless steel cover plate**

With indicator (for wheelchair use)

**Car button types**

**Plastic** **Standard**

**Stainless steel hairline** **Option**

**Illumination colors**<sup>\*1</sup>

Red White Yellow

The car operating panel is installed on the side panel in the following cases:

- Front panel width: Less than 300mm

## Hall operating panels

**Stainless steel cover plate**

**Incorporated type (dot-matrix)** **Standard**

**Incorporated type (LCD)** **Option**

VIB-14B/D VIB-14B/L

**Separate type** **Option**

**Separate type (for wheelchair use)** **Option**

HBC

**Car position indicators (LCD)** **Option**

In addition to the standard white, you can select black or blue as the background color.

White (standard color) Black Blue

**Horizontal indicators** **Option**

**Stainless steel cover plate**

**Dot-matrix**

HF-119

**LCD**<sup>\*1</sup>

HF-CL11

**Hall button types**

**Plastic** **Standard**

**Stainless steel hairline** **Option**

P14F-UL UB15R-2 UB15R-4

UB15S-2 UB15S-4

**Illumination colors**<sup>\*3</sup>

Red White Yellow

**Hall lanterns** **Option**

**Stainless steel cover plate**

**Square lanterns (LED)** **Round lanterns (LED)**

HLC-304<sup>\*2</sup> HLC-303<sup>\*2</sup>

**Triangle lanterns (horizontal type) (LED)**

HLS-025S2









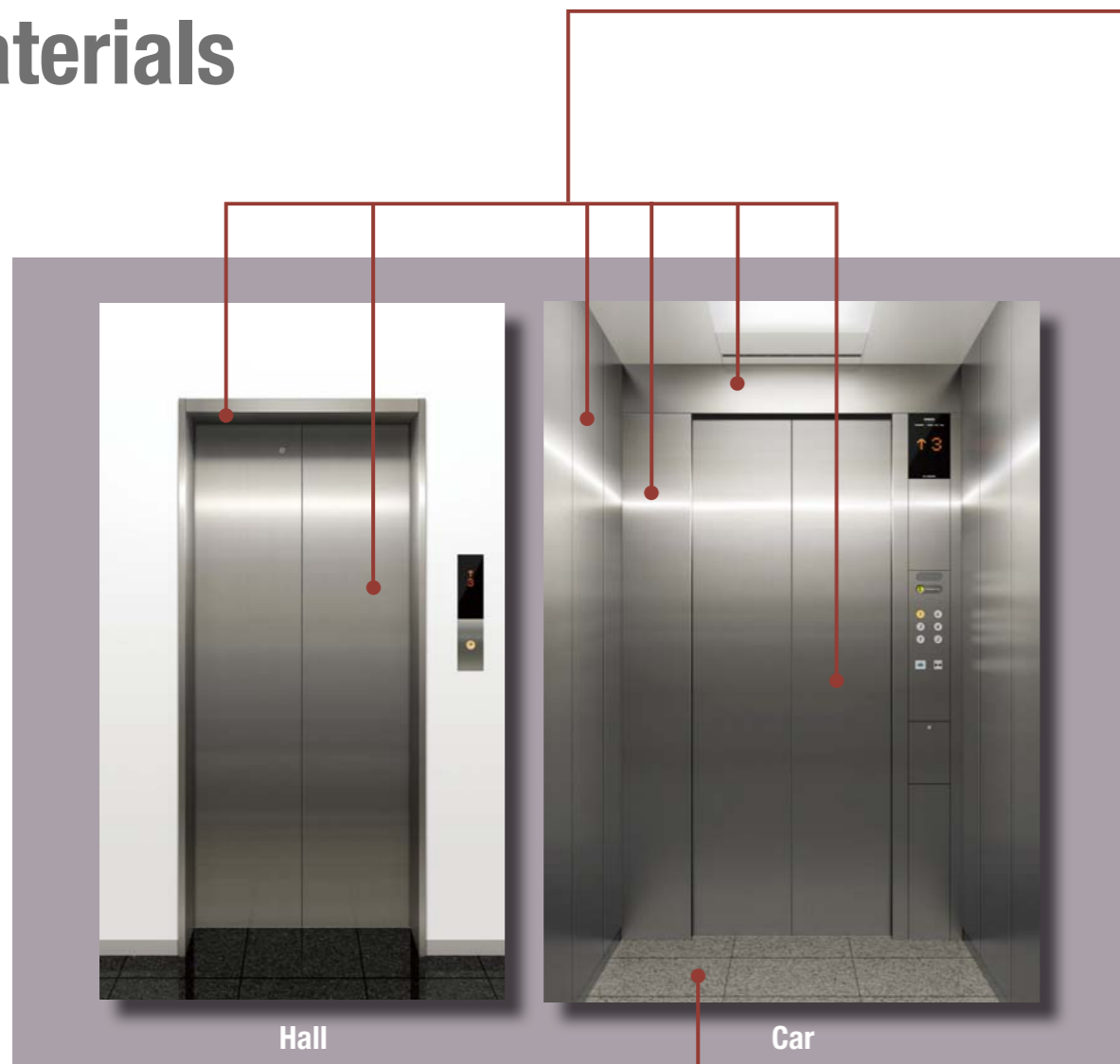

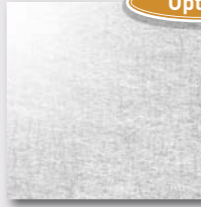





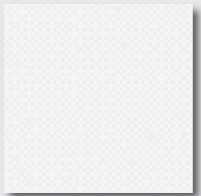
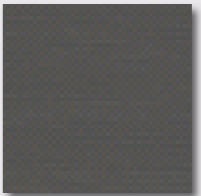

**Triangle lanterns with dot-matrix indicator (LED)**

HLS-025SD2

\*1 LCD back light can be changed to black or blue.  
 \*2 Stainless steel non-directional hairline cover is available (Option).  
 Lantern illumination color can be changed to white.  
 \*3 Illustrations colors are only applicable for stainless steel hairline buttons.

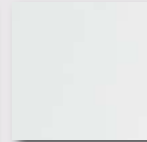
# Materials



Hall		Car			
Jamb	Door	Door	3 side walls	Front wall	Transom
<b>Stainless steel</b>					
	 <p>Standard</p> <p>Hairline*1</p>	 <p>Option</p> <p>Non-directional hairline</p>	 <p>Option</p> <p>Mirror</p>		
<b>Stainless steel hairline etching</b> <span>Option</span>					
	 <p>SD-1006</p>	 <p>SD-1010</p>	 <p>SD-1038</p>	 <p>SD-1046</p>	
<p>■ : Etched area   ■ : Non etched area</p>					
<b>Decorated steel</b> <span>Option</span>					
	 <p>Minamo white</p>	 <p>Craft wood</p>	 <p>Mocha wood</p>		
<b>Laminated plastic sheet (LPS)*2</b> <span>Option</span>					
	 <p>7170UN Metal Pearl Rosewood</p>	 <p>2726NT Natural Beech</p>	 <p>5261NT Sandy Sakura</p>	 <p>5474UN Silverbrush Wood-Cross</p>	
	 <p>5475SP Blondbrush Wood-Cross</p>	 <p>7171UN Metal Pearl Steel</p>	 <p>7158UN Cosmic Dusk</p>	 <p>7157UN Cosmic Dawn</p>	
	 <p>0869NT Powdered Oak</p>	 <p>8834NT Smoke Strand</p>	 <p>6006UN Canadian Pine (Straight)</p>		

## Floor Standard

### Vinyl tile\*1

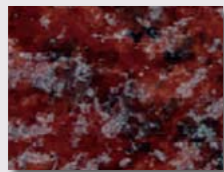

GA 201

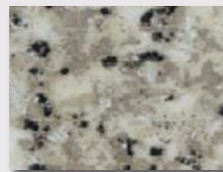

GA 202



GA 204



GA 205



SA 605



SA 606



SA 614

\*1 These tiles are not compliant with EN81-20/50, but they can be used if the customer agrees.  
Note: It is also possible to use floor materials supplied by the customer.

\*1 SUS430(Standard), SUS304(Option)  
\*2 LPS is not compliant with EN81-20/50, but it can be used if the customer agrees.  
Note: The colors printed in the catalog may differ slightly from the actual colors.

# Design variations

## Car design variations

● : Standard, ○ : Option, - : Not applicable

No.	Item	Finishes/Types	Passenger Service	Bed*1
1	Ceiling*2	Standard (BS-11)*3	●	●
2		Select (SL-11)*3 (SL-11-Oriental mosaic)*3 (SL-11-Cube)*3 (SL-11-Kaleidoscope)*3 (SL-12)	○	○*4
3		Deluxe (DX-101)*3 (DX-101-Lattice)*3 (DX-101-Geometric star)*3 (DX-101-Arabesque)*3 (DX-11)	○	○
4	Car door/3 side walls	Stainless steel hairline	●	●
5		Stainless steel hairline etching (SD-1006)(SD-1010)(SD-1038)(SD-1046)	○	○
6		Stainless steel mirror	○	○
7		Stainless steel non-directional hairline	○	○
8		Decorated steel*5 (Minamo white)(Craft wood)(Mocha wood)	○	○
9		Laminated plastic sheet*6,7 (7170UN)(2726NT)(5261NT)(5474UN)(5475SP)(7171UN)(7158UN)(7157UN)(0869NT)(8834NT)(6006UN)	○	○
10	Rust proof painted steel	○	○	
11	Front wall/transom	Stainless steel hairline	●	●
12		Stainless steel hairline etching (SD-1006)(SD-1010)(SD-1038)(SD-1046)	○	○
13		Stainless steel mirror	○	○
14		Stainless steel non-directional hairline	○	○
15		Decorated steel	○	○
16	Rust proof painted steel	○	○	
17	Kick plate	Stainless steel hairline	●	●
18	Sill	Extruded hard aluminum	●	●
19		Stainless steel	○	○
20	Floor*7,8	Vinyl tile (GA201) (GA202) (GA204) (GA205) (SA605) (SA606) (SA614)	●	●
21	Handrail	Round type Stainless Steel hairline Diameter: 32mm (one row)	○	-
22		Flat type Stainless Steel hairline Width: 50mm (one row)	○	-
23		Aluminum Width: 90mm (two rows)	-	●
24	Car operating panel	Vertical*9 Dot-matrix indicator (OPV/D)	●	●
25		LCD indicator (OPV/L) (White, Black, Blue)	○	○
26		Horizontal Without indicator	○	○
27	Horizontal for wheelchair Dot-matrix indicator	○	○	
28	Car operating panel cover plate	Stainless steel hairline	●	●
29		Stainless steel mirror	○	○
30		Stainless steel non-directional hairline	○	○
31	Button type	Plastic(P14F-UL)	●	●
32		Stainless steel hairline*10 (UB15R-2)(UB15R-4)(UB15S-2)(UB15S-4)	○	○

\*1 Bed type: Available for Thailand, Myanmar, Cambodia, Laos, Philippines, Vietnam, Macau, Indonesia and Saudi Arabia.  
 \*2 It is also possible to use materials supplied and installed by the customer.  
 \*3 These ceilings are not compliant with EN81-20/50, but they can be used if the customer agrees.  
 \*4 SL-12 not available on bed type.  
 \*5 Not applicable if the ceiling height or entrance height is increased from standard.  
 \*6 LPS comes with stainless steel hairline trim edge.  
 \*7 These tiles and LPS are not compliant with EN81-20/50, but they can be used if the customer agrees.  
 \*8 When flooring is supplied by the customer, floor recess shall be 20mm or 25mm.  
 \*9 Depending on size of car, may be mounted on side wall.  
 \*10 The available button illumination colors are yellow, red, white.

## Hall design variations

● : Standard, ○ : Option

No.	Item	Finishes/Types	Passenger Service	Bed*1	
1	Jamb type	AS-1X	●	●	
2		SS-1X	○	○	
3		TS-1X	○	○	
4	Jamb finish	Stainless steel hairline	●	●	
5		Stainless steel mirror	○	○	
6		Stainless steel non-directional hairline	○	○	
7		Rust proof painted steel	○	○	
8	Hall door	Stainless steel hairline	●	●	
9		Stainless steel hairline etching (SD-1006)(SD-1010)(SD-1038)(SD-1046)	○	○	
10		Stainless steel mirror	○	○	
11		Stainless steel non-directional hairline	○	○	
12	Laminated plastic sheet*2,3 (7170UN)(2726NT)(5261NT)(5474UN)(5475SP)(7171UN)(7158UN)(7157UN)(0869NT)(8834NT)(6006UN)	○	○		
13	Rust proof painted steel	○	○		
14	Sill	Extruded hard aluminum	●	●	
15		Stainless steel	○	○	
16	Hall button cover plate	Incorporated indicator	Stainless steel hairline	●	●
17			Stainless steel mirror	○	○
18		Separate indicator	Stainless steel non-directional hairline	○	○
19			Stainless steel hairline	○	○
20	Hall button cover plate for wheelchair use	Incorporated indicator	Stainless steel mirror	○	○
21			Stainless steel non-directional hairline	○	○
22		Separate indicator	Stainless steel hairline	○	○
23	Stainless steel mirror		○	○	
24	Indicator	Vertical	Stainless steel non-directional hairline	○	○
25			Stainless steel hairline	○	○
26		Horizontal	Stainless steel mirror	○	○
27	Stainless steel non-directional hairline		○	○	
28	Horizontal indicator cover plate	Vertical	Dot-matrix	●	●
29			LCD(White,Black,Blue)	○	○
30		Horizontal	Dot-matrix (HF-119)	○	○
31			LCD (HF-CL11) (White,Black,Blue)	○	○
32	Button type	Horizontal indicator cover plate	Stainless steel hairline	○	○
33			Stainless steel mirror	○	○
34			Stainless steel non-directional hairline	○	○
35	Lantern	Vertical	Plastic(P14F-UL)	●	●
36			Stainless steel hairline*4 (UB15R-2)(UB15R-4)(UB15S-2)(UB15S-4)	○	○
37	Lantern cover plate	Vertical	Square lanterns (HLC-304) (Orange,White)	○	○
38			Round lanterns (HLC-303) (Orange,White)	○	○
39		Horizontal	Triangle lanterns (HLS-025S2)	○	○
40			Triangle lanterns with dot-matrix indicator (HLS-025SD2)	○	○
41	Lantern cover plate	Horizontal	Stainless steel hairline	○	○
42			Stainless steel mirror	○	○
43			Stainless steel non-directional hairline	○	○

\*1 Bed type: Available for Thailand, Myanmar, Cambodia, Laos, Philippines, Vietnam, Macau, Indonesia and Saudi Arabia.  
 \*2 LPS comes with stainless steel hairline trim edge.  
 \*3 LPS cannot be used in the landing area when fire rated doors are selected.  
 \*4 The available button illumination colors are yellow, red, white.

# Functions

● : Standard, ○ : Option

No.	Name	Description	Passenger Service	Bed <sup>*1</sup>
<b>Operating systems</b>				
1	<b>Simplex collective control</b>	This is a fully automatic operation used for a single elevator system. Hall calls in the direction in which the elevator is travelling are responded to sequentially and when all calls in that direction are cleared, calls in the opposite direction are responded to. When there are no more calls, the elevator will stop at the last floor served.	●	●
2	<b>Duplex collective control</b>	This is a fully automatic operation used for a two-elevator system. Hall calls are responded to by whichever elevator that can serve the hall call faster. When there are no more calls, one of the elevators will stand by at the stand by floor while the other elevator will stay at the last floor served.	○	○
3	<b>Group control</b>	<b>FI-10</b> This is a simplified group control system used to operate three or four elevators. The system provides a control to assign the elevator car closed to the floor where a new hall call is registered.	○	○
4		<b>FI-100</b> This is a group control system used to operate three to six elevators in a medium-sized building. This control system uses "reference-trajectory control", which is based on the theory used in the highest model of the "future reference-trajectory control".	○	○
<b>Service functions</b>				
1	<b>Automatic return function</b>	After all the calls have been served, the elevator will return to the stand by floor for stand by.	○ <sup>*2</sup>	○ <sup>*2</sup>
2	<b>Attendant operation</b>	For this system, the stop floor is manually set by an attendant, such as in a department store.	○	○
3	<b>Independent operation</b>	This operation system is used when there is a need to serve special passengers. Under this operation, all hall calls are disabled for the elevator and it is reserved for exclusive use of the special passengers.	○	●
4	<b>Parking operation</b>	The elevator can be parked at the parking floor by a key switch.	○ <sup>*3</sup>	○ <sup>*3</sup>
5	<b>Rush-hour schedule operation</b>	All the elevators will automatically return to the stand by floor, after serving the last call during this preset rush-hour timing.	○	○
6	<b>Separated simplex operation</b>	When duplex collective control or group control is used, a selector switch on the control panel is used to switch between parallel operation and independent operation.	○	○
7	<b>Interphone system</b>	An interphone system is provided for emergency communication between the elevator and the master unit in the supervisory panel, etc.	●	●
8	<b>Floor lock-out operation</b>	Specific service floors can be locked-out by activating a switch.	○	○
9	<b>Temporary call registration of certain restricted floor</b>	By inputting a pre-programmed code using the car operating board floor buttons, passengers can gain access to certain restricted floors.	○	○
10	<b>Door nudging operation</b>	When the door has been open for a certain period of time, a buzzer sounds and the door forcibly closes.	○	○
<b>Safety functions</b>				
1	<b>Abnormal speed protection function</b>	In the event that the elevator is moving downwards at an abnormally high speed, the brakes will be automatically engaged and the elevator will cease operation.	●	●
2	<b>Out of door-open zone alarm</b>	In the event that the elevator stops out of the door-open zone of a selected floor, doors will not open, and an alarm will be sound in the elevator.	●	●
3	<b>Rescue operation</b>	When the elevator stops out of the door-open zone, it will move to the nearest floor at slow speed to release passengers.	●	●
4	<b>Door safety return system</b>	In the event of door overload, such as when passengers get their fingers, hands or personal belongings caught in the door, this system automatically senses this and either re-closes or re-opens the doors to prevent injury.	●	●
5	<b>Micro-leveling</b>	Automatic correction of elevator landing level when there is a level difference between car and floor.	●	●
6	<b>Car emergency lighting</b>	In the event of a power failure, an emergency light inside the elevator will be automatically activated.	●	●
7	<b>Emergency battery</b>	In the event of a power failure, this emergency supply allows the operation of a light, fan and alarm bell.	○	○
8	<b>Multi-beam door sensor</b>	In the event that the beam paths are obstructed, this sensor, installed at the edge of the doors, will keep the doors open.	●	●
9	<b>Door signal with multi-beam door sensor</b>	In addition to the multi-beam door sensor, the safety shoe is equipped with a signal that indicates when the doors are starting to close. (2PCO : Both side, 2S2P : One side)	○	○
10	<b>Door safety edge</b>	Mechanical safety units are installed on both sides(2PCO) or one side(2S2P) of the elevator doors. In the event of passengers coming into contact with the safety edges of closing doors, the doors will immediately reopen.	○	○

\*1 Bed type: Available for Thailand, Myanmar, Cambodia, Laos, Philippines, Vietnam, Macau, Indonesia and Saudi Arabia.  
 \*2 Included in the standard configuration when duplex collective control or group control are selected.  
 \*3 Included in the standard specifications for Thailand, Laos, Myanmar, and Cambodia.

● : Standard, ○ : Option

No.	Name	Description	Passenger Service	Bed <sup>*1</sup>
<b>Accessibility</b>				
1	<b>Car floor button flashing</b>	The registered car destination floor button flashes when the car approaches the floor.	●	●
2	<b>Braille plate</b>	Braille plates are fixed next to the operation buttons in the car and hall.	○	○
3	<b>Sound button</b>	An electronic tone sounds when the buttons are pressed to confirm call registration.	○	○
<b>Security functions</b>				
1	<b>Intelligent operation security system by card reader (By others)</b>	This function allows controlled access to certain floors by means of a password or ID cards. Note: Keypad or ID card-reader system is to be provided and installed by others. Interfacing shall be by means of dry (voltage-free) contacts.	○	○
2	<b>CCTV (Camera by others, coaxial cable by Hitachi)</b>	This system enables the security personnel to monitor inside the elevator car. This will be effective in preventing criminal and mischievous acts inside the elevator car. (CCTV system, including wiring, is to be supplied by others.)	○	○
<b>Information functions</b>				
1	<b>IC auto announcement (English / Thai / Mandarin / Cantonese / Portuguese)</b>	Preset standard messages are announced to the passengers.	○	○
2	<b>Public address speaker</b>	A speaker for background music and public announcements for the building can be installed in the elevator. (Music and announcement systems, including wiring, is to be provided by others)	○	○
3	<b>Arrival audio signal</b>	An electrical chime (located at the top and bottom of the elevator) will sound just before the arrival of the elevator.	○	○
<b>Energy-saving functions</b>				
1	<b>Regenerative system</b>	When traveling downwards with a heavy car load or upwards with a light car load, the traction machine acts as a power generator to transmit power back to the electrical network in the building.	○	○
2	<b>Automatic turn-off of elevator light and fan</b>	In the event that the elevator is not in use, the light and ventilation fan in the elevator are automatically turned off to conserve energy.	●	●
<b>User services</b>				
1	<b>Door open time adjustment</b>	The duration of the door open timing is tailored to usage conditions, substantially improving operational efficiency.	●	●
2	<b>Door open prolong button</b>	In the event that this button on the car operation board is pressed, the elevator doors remain open for a pre-set period of time.	○	●
3	<b>Automatic bypass operation</b>	In the event that the elevator is fully loaded, this operation will not respond to any hall calls and will only respond to the car calls.	○	○
4	<b>Mischievous call cancellation</b>	In the event that a large number of calls is registered by a small number of passengers, the calls are determined to be mischievous and will be automatically cancelled upon responding to the next call. This eliminates unnecessary stops.	●	●
5	<b>Floor "deselect" function</b>	This function allows passengers to cancel the selection of a floor which is accidentally pressed by pressing the button again. (This eliminates unnecessary stops.)	●	●
6	<b>Supervisory panel</b>	This panel provides various supervisory operations, including communication and status monitoring.	○	○
7	<b>Elevator monitoring system (EMS)</b>	This system shows the real time situation of the elevators such as the elevator position, movement direction and abnormal operation on the PC (Personal Computer) display. It is also possible to turn on/off the elevators and change the service floors of the elevators using the PC.	○	○
8	<b>Ion generator<sup>*2</sup></b>	A device that generates ionized microparticles enclosed in water is mounted on top of the car to ensure pleasant air quality inside the elevator.	○	○

\*1 Bed type: Available for Thailand, Myanmar, Cambodia, Laos, Philippines, Vietnam, Macau, Indonesia and Saudi Arabia.  
 \*2 The ion generator is not available in the following cases:  
 (1) When the ceiling is supplied by the customer.  
 (2) When the car internal depth is 1,250mm or less.



# Functions

● : Standard, ○ : Option

No.	Name	Description	Passenger Service	Bed <sup>1</sup>
<b>Emergency operations</b>				
1	<b>Earthquake emergency operation</b>	In the event that an earthquake is detected, the elevator will stop at the nearest floor.	○	○
2	<b>Fire emergency operation</b>	In the event of fire, the elevator is automatically brought to the designated floor where it remains inoperative for passengers' safety.	○	○
3	<b>Automatic rescue device for power failure</b>	In the event of power failure, this system automatically switches to battery power to bring the elevator to the nearest floor.	○	○
4	<b>Emergency operation for power failure</b>	In the event of building power failure, the elevator can be operated by the building standby generator to move the elevator to the designated floor. (Automatic / Automatic and manual)	○	○
5	<b>Fireman operation</b>	In the event that the fireman switch is turned on, the elevator returns to the designated floor and will be ready for firemen's use.	○	○
<b>Other functions</b>				
1	<b>Counterweight safety</b>	A safety device is installed on the counterweight to maintain the rails and prevent falling.	○	○
2	<b>Over voltage detection device</b>	When an abnormal increase in power supply voltage to the elevator system is detected, the power supply will be cut off to prevent damages to the elevator equipment.	○	○
3	<b>Maintenance operation</b>	Elevator operates at lower speed during maintenance.	●	●
4	<b>Overload detection system</b>	In the event of overloading, this system will activate an audio/ visual signal to prevent the elevator from moving.	●	●
5	<b>Nearest landing door operation</b>	In the unlikely event of temporary trouble during operation, the elevator automatically goes to the nearest floor at a low speed and doors will open to prevent passengers from being trapped inside.	●	●
6	<b>Hook for protection sheet</b>	The side walls are equipped with hooks to facilitate mounting of protective mats.	○	○
7	<b>Sub-operating panel</b>	Additional floor selection and door open/close buttons are located on the side opposite the main operating panel.	○	○
8	<b>Fire rated door</b>	2 hours fire rated landing doors are available where required.	○	○
9	<b>Emergency landing door</b>	If there is a long distance between floors, doors are installed in a location where the elevator can stop automatically in an emergency.	○	○
10	<b>Switch for emergency exit</b>	A switch stops the elevator when the emergency exit door is opened.	○	○
11	<b>Painted equipment inside hoistway</b>	Equipment in the hoistway is painted black.	○	○
12	<b>Electromagnetic compatibility (EMC)</b>	Electromagnetic compatibility function due to EN81-20/50 regulation, etc.	○	○
13	<b>Interfacing to building management system</b>	This interfacing shall be done by means of electrical dry contact to the building management system for their monitoring.	○	○

\*1 Bed type: Available for Thailand, Myanmar, Cambodia, Laos, Philippines, Vietnam, Macau, Indonesia and Saudi Arabia.

## Dimensions

-  Building structure (by other contractors)
-  Wall and floor finishing (by other contractors)
-  Grouting (by other contractors)

(unit: mm)

### AS-1X (2PC0) Standard

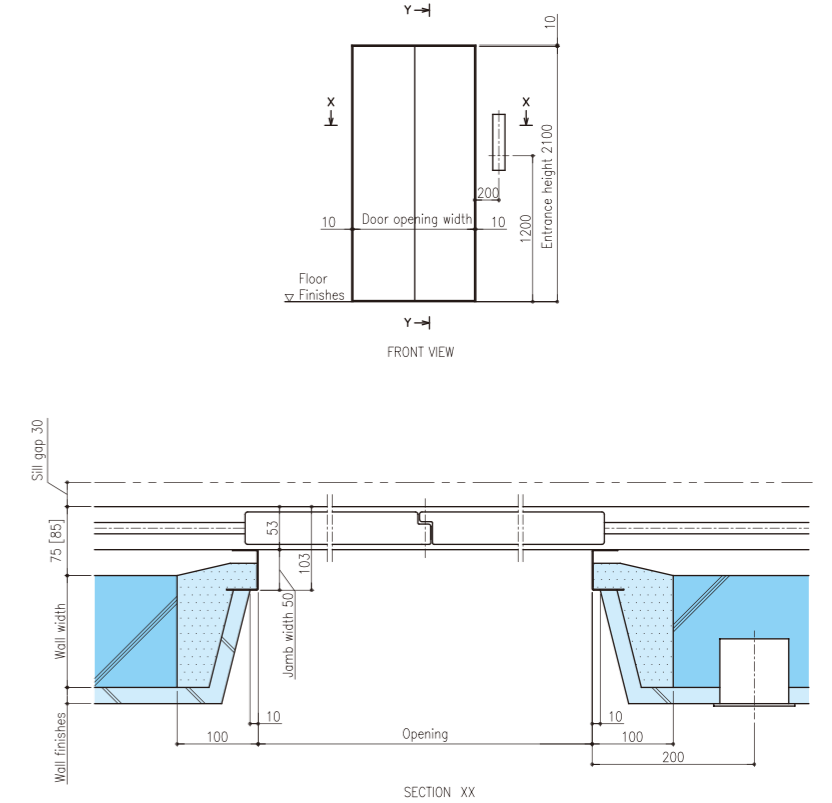
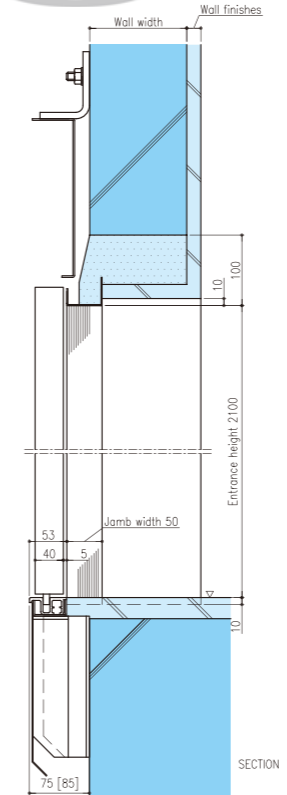



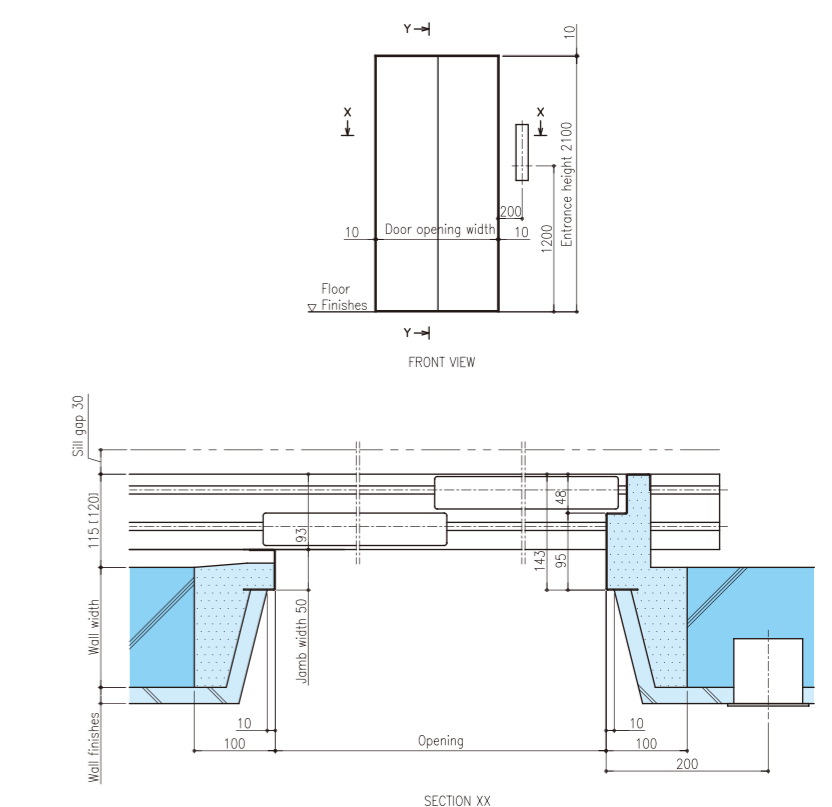
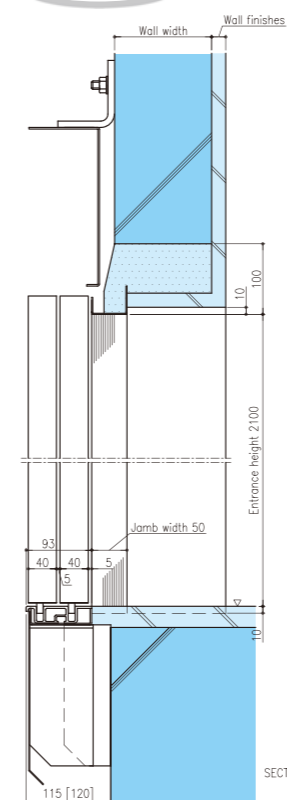



### AS-1X (2S2P) Standard



Note: [ ] : With fire rated door

# Dimensions

-  Building structure (by other contractors)
-  Wall and floor finishing (by other contractors)
-  Grouting (by other contractors)

-  Building structure (by other contractors)
-  Wall and floor finishing (by other contractors)
-  Grouting (by other contractors)

## SS-1X(2PC0) Option

(unit: mm)

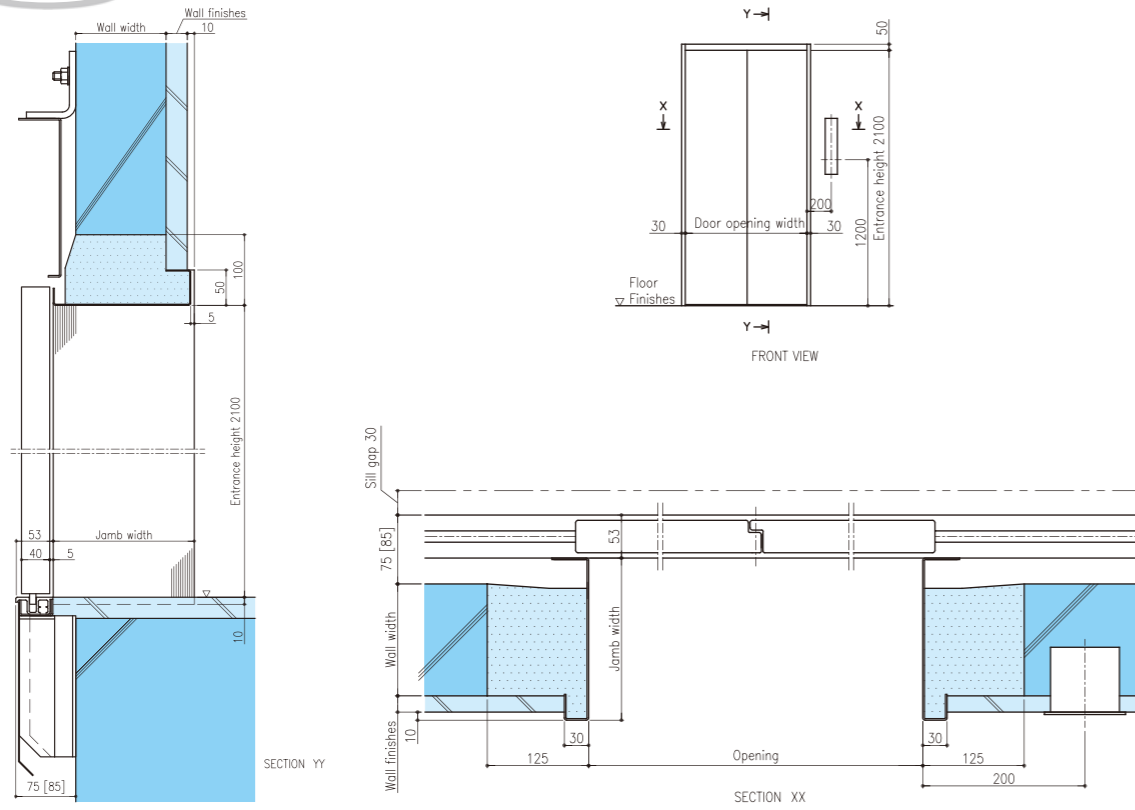

## TS-1X(2PC0) Option

(unit: mm)

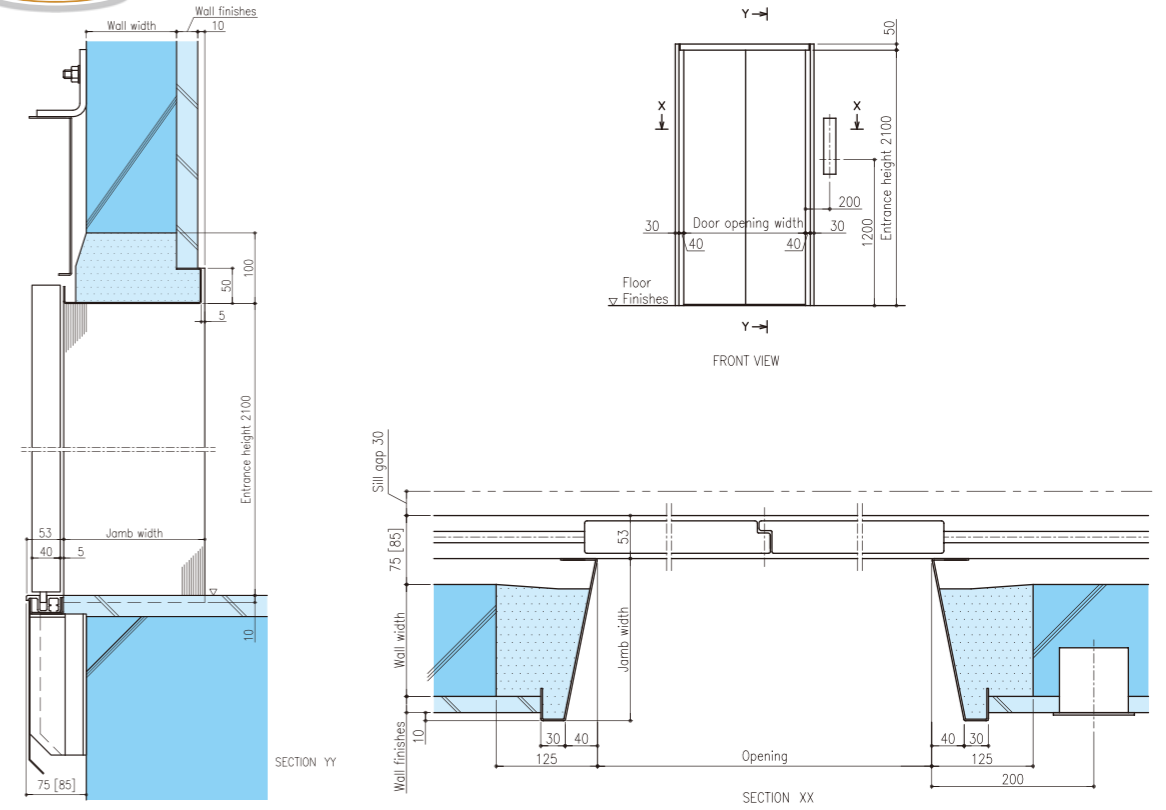

## SS-1X(2S2P) Option

Note: [ ] : With fire rated door

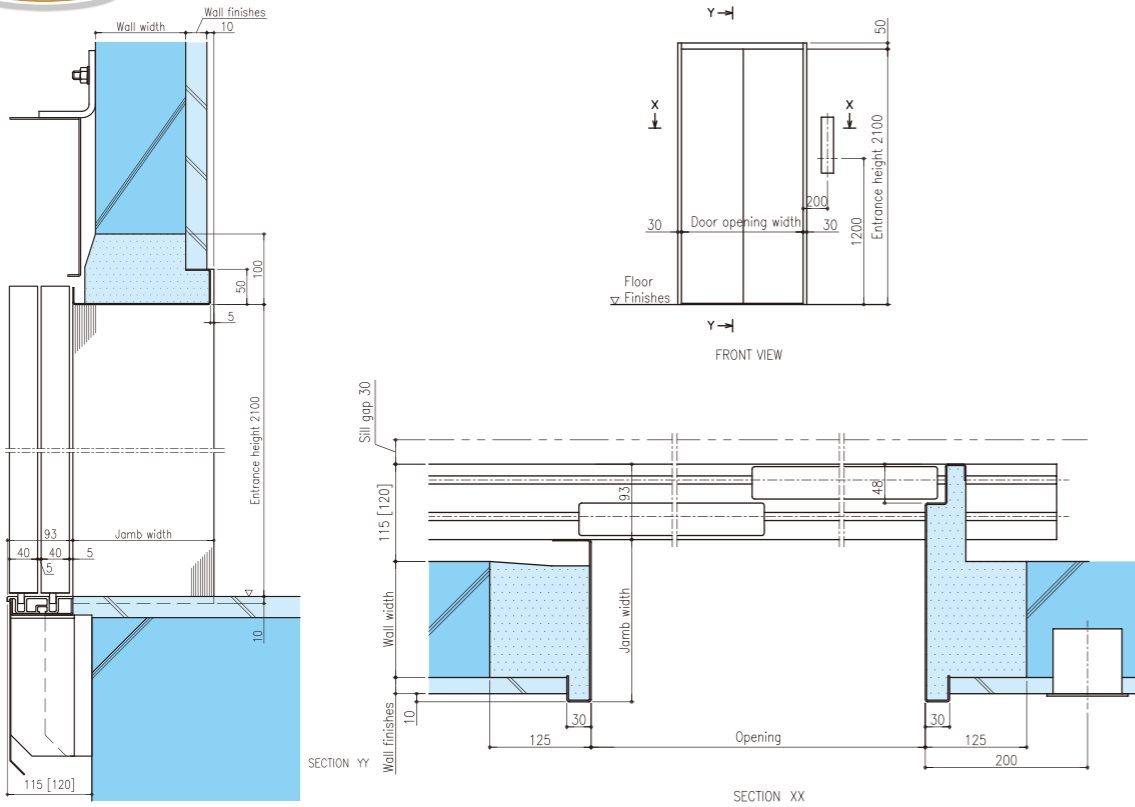

## TS-1X(2S2P) Option

Note: [ ] : With fire rated door

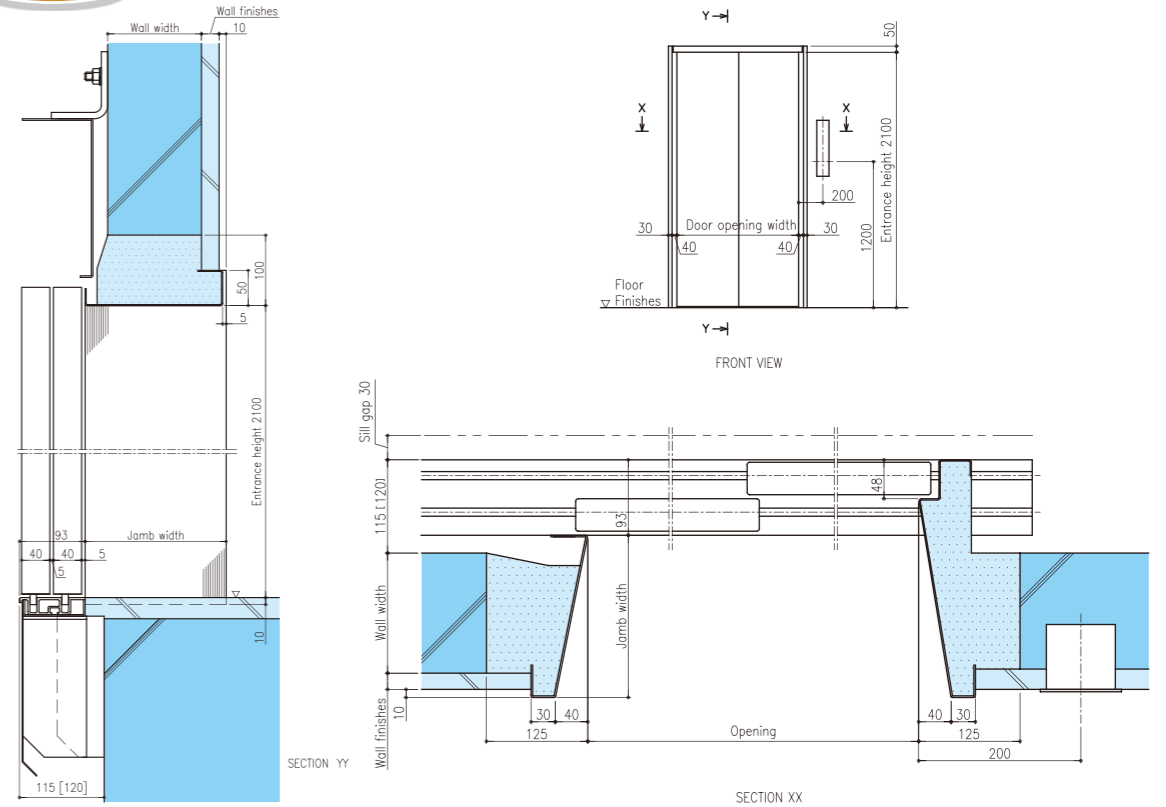



## Work to be done by building contractors

The preparatory work for elevator installation outlined in below table should be undertaken by building contractors in accordance with Hitachi drawings and in compliance with local or relevant codes and regulations

No.	ITEMS
1	Prepare hoistway with proper framing and enclosure, suitable pit of proper depth with drains and water-proofing if required, properly lit and ventilated hoistway of adequate size with concrete floors, access doors, ladders and guards as required.
2	Provide and / or cut all necessary holes, chases, openings and finishes after equipment installation.
3	Supply and secure all supports, reinforced concrete slabs, etc., necessary for installation of the machinery, doors, buffers, etc.
4	Furnish all necessary cement and / or concrete for grouting of brackets, bolts, machine beams, etc.
5	Prepare and erect suitable scaffolding and protective measures during work in progress.
6	Furnish mains for three-phase electric power and single-phase lighting supply for car lighting and lift pit and power outlet to the hoistway, following the instructions of the elevator contractor on outlet position and wire size.
7	Provide, free of charge, a suitable theft-proof storage area for materials and tools during erection work.
8	Supply electric power for lighting of work area, installation work, elevator testing and spray painting.
9	Hoisting hook at top of the hoistway.
10	Hoistway ventilation to be provided to maintain the hoistway temperature at below 40°C.
11	Manufacture and installation of separating beam (if necessary).



## Our achievement & Future

# The ultra-high-speed elevators

Hitachi delivered the ultra-high-speed elevators, with a speed of 1,200 m/min. (20 m/sec.), to the Guangzhou CTF Finance Centre (530 meters tall), a mixed-use skyscraper in Guangzhou, China, for the full opening of the building in 2016. The elevators feature technologies that support safe and comfortable operation, in addition to the drive and control technologies needed to attain the ultra-high-speeds. Through these technologies, Hitachi ensures that the elevators provide passengers with a comfortable ride even when operated at high speeds.

## Hitachi Eco-Achievement

### HITACHI's elevators achieved the highest energy efficiency class rating.

ISO 25745 is an international standard for evaluating the energy consumption and classifying the energy efficiency of elevators and escalators. ISO 25745-2 applies to the energy efficiency of elevators. It establishes seven classes, from A to G, with class A representing the highest level of energy efficiency.

Hitachi's UAG-SN1 and OUG-ON1 have achieved the highest rating.

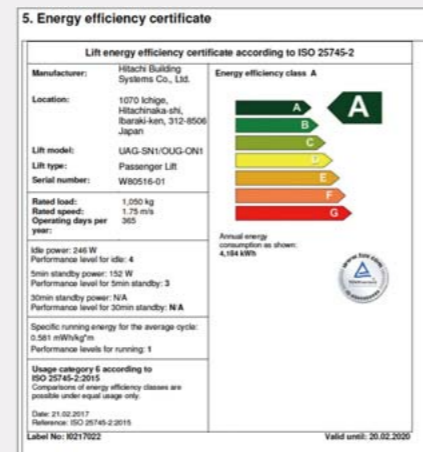

#### Energy efficiency class A

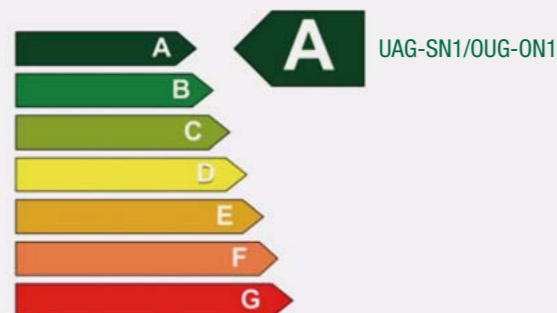

Model	UAG-SN1/OUG-ON1	UAG-SN1/OUG-ON1
Location	Japan	Japan
Rated load	1,050 kg	1,635 kg
Rated speed	1.75 m/s	1.75 m/s
No. of stops	4	4
Travel	19.5 m	19.5 m
Operating days per year	365	365
Annual energy consumption	4,184 kWh	4,633 kWh
Usage category	6	5
Classification of lift [A-G]	A	A

Note: The measured class differs depending on the usage conditions.

### 1 Drive and control technologies to attain the ultra-high-speed of 1,200 m/min.

Hitachi has developed a permanent magnet synchronous motor that achieves both a thin profile and the high output needed to attain a speed of 1,200 m/min.



Traction mechanism for 1,200 m/min.

### 2 Safety features supporting ultra-high-speed elevator operation.

Hitachi developed brake equipment using Hitachi developed brake equipment using outstanding heat resistance to safely stop the elevator car in the unlikely event that a malfunction is detected during ultra-high-speed operation.

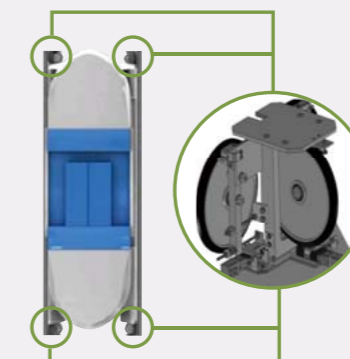

Active guide rollers (3D model)

### 3 Elevators can be used comfortably and safely even over long travel.

- Active guide rollers that detect minute warping in the guide rails and lateral vibration due to wind pressure are installed in the four corners (top and bottom, left and right) of the elevator car. This gives passengers a comfortable ride even during high-speed operation.

- The sensation of ear blockage is reduced by Hitachi's proprietary air pressure adjustment technology, which reduces the changes in air pressure inside the elevator car that would otherwise be caused by vertical movement through long travel.



## Research and development

Modern manufacturing plants in Thailand and Singapore supply valuable products to customers. Equipment is made to the highest standards of quality and reliability on cutting-edge production lines.



Siam Hitachi Elevator Co., Ltd. (Thailand)



Hitachi Elevator Asia Pte., Ltd. (Singapore)

### Excellence and flexibility in design at manufacturing plants in Thailand and Singapore

The modern manufacturing plant in Thailand and Singapore boasts a complete team of local and Japanese engineers and is geared towards providing maximum flexibility in design and manufacturing to suit customer requirements.

High accuracy and efficiency in planning of equipment layout is made possible by the most advanced CAD systems.

Equipment is made to the highest standards of quality and reliability with modern CNC machinery.



Mito Works, Hitachi, Ltd. (Japan)

### An integrated engineering system from development to design and production

#### Head office, research centers, and plants work closely together to develop new technologies.

Staff throughout the company work together as one team to conduct research and develop technologies.

#### High performance simulator enhances overall elevator system efficiency.

A high-performance simulator is utilized for all stages of elevator development, from planning through system design. Planning, research and development are carried out according to the results of this statistical analysis.

#### Cutting-edge CAD/CAM systems

The latest in CAD/CAM systems help us carry out elevator layout and various other design and production steps more quickly and efficiently.



Hitachi provides a wide array of products and services – from home appliances to societal infrastructure. We integrate the capabilities of our entire group at a high level, taking on the challenge of innovation to build a better future without losing sight of the perspective of our customers. Our development of superior, innovative technology and products supports a safe, secure, comfortable lifestyle and a fair society for all. This is the conviction that infuses Hitachi's craftsmanship.

- Information and telecommunication systems
- Power systems
- Social infrastructure and industrial systems
- Electronic systems and equipment
- Construction machinery
- Highly functional materials and components
- Automotive systems
- Smart life and eco-friendly systems



# Location of hoisting hook and hoisting beam

If the hoistway is made of reinforced concrete, hoisting hooks (installed by other contractors) are required at the top of the hoistway. If the hoistway is a steel structure, hoisting beams (installed by other contractors) are required at the top of the hoistway. The details of the hoisting hook and hoisting beam mounting position are as follows:

## ① Hoisting hooks

### 1. Rated Load ≤ 1020kg

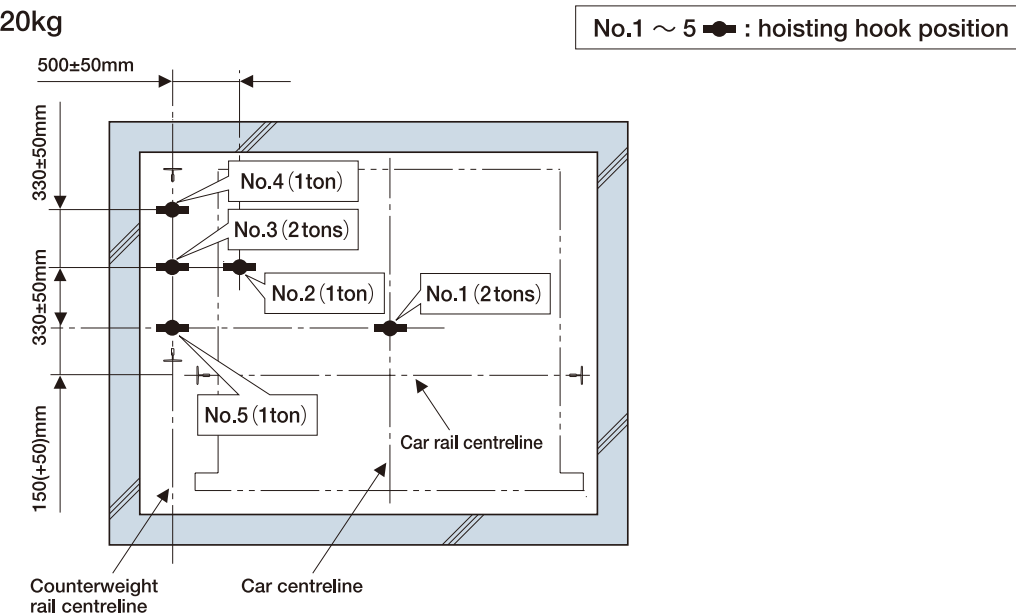

### 2. Rated Load ≥ 1150kg

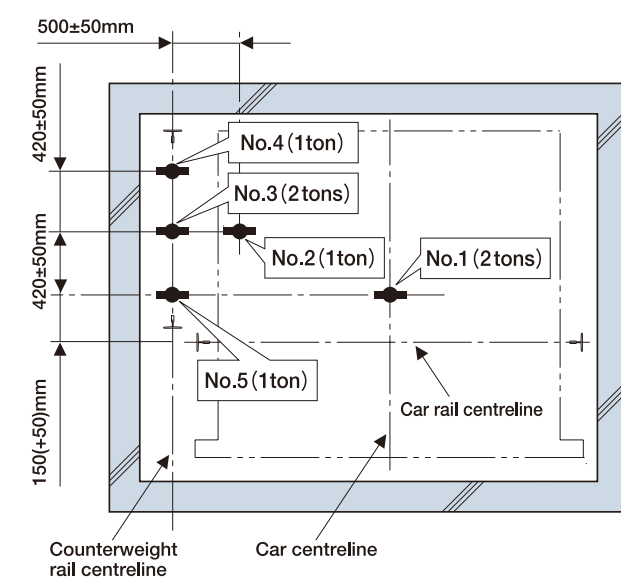

### 3. Orientation and size of Hoisting Hooks

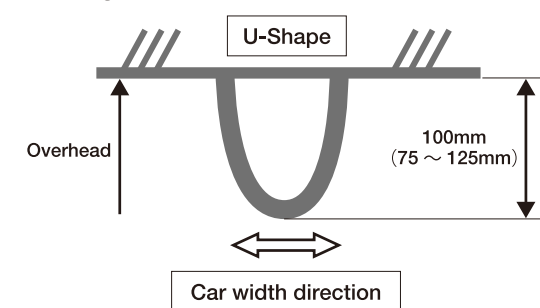

Note: 1. The hoisting hooks should be orientated such that the U-shape is facing the hoistway landing entrance.  
2. This hoisting hook size is required to ensure that the hoisting equipment can fit in.

UAG-SN1

## ② Hoisting beams

### 1. Hoisting beams layout (Standard)

Hoisting beams in the direction of car depth

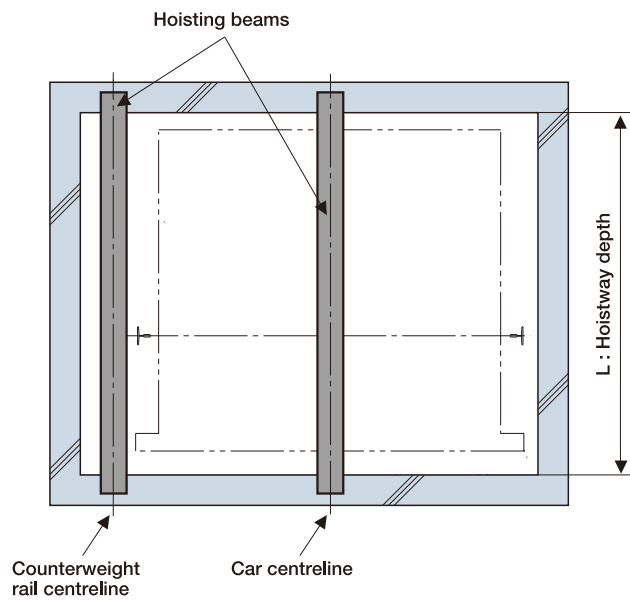

### 2. Hoisting beams layout (Alternative)

Hoisting beams in the direction of car width

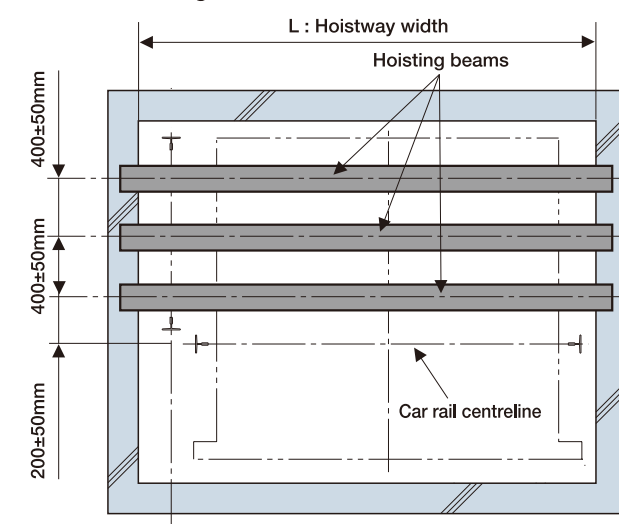

### 3. Height of Hoisting beams

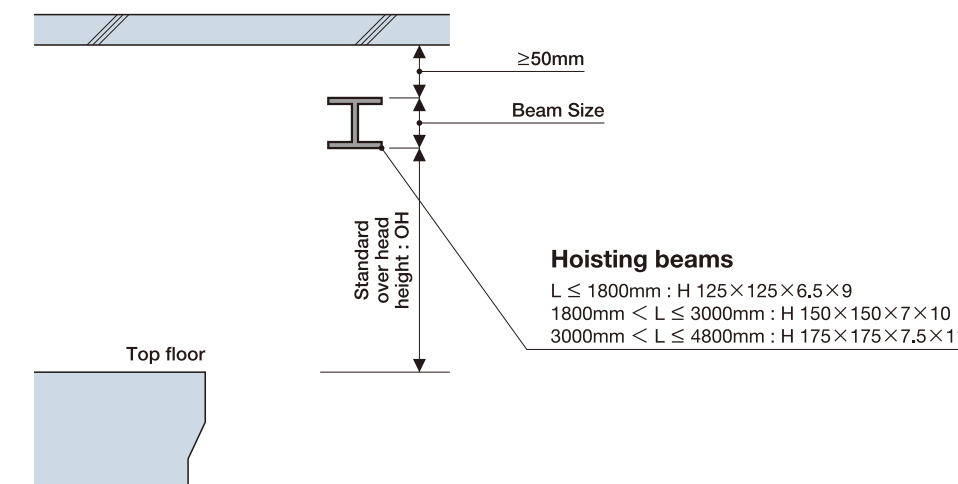

UAG-SN1

# Electrical information

## Required capacity of circuit breaker, transformer & starting power at building side

### ■ Electrical Data

No.	Load [kg]	Rated speed [m/s] (m/min)	Motor capacity [kW]	Supply voltage [V]	Breaker capacity [A]			Transformer capacity [kVA]			Starting power [kVA]	Lead-in wire for drive [mm <sup>2</sup> ]			Earth wire [mm <sup>2</sup> ]	Calorific value *1 [kcal/hr]	
					1 unit	2 units	3 units	1 unit	2 units	3 units		1 unit	2 units	3 units			
1	600 (612)	1.0(60)	3.9	220-230	100	125	150	5	9	12	15	22	38	60	3.5	800 (810)	
2				380-415	20	30	30					14	14	14			2.0
3				440-480	50	75	100					5.5	8	14			2.0
4		1.5(90)	5.8	220-230	100	125	150	6	11	15	20	22	60	60	3.5		
5				380-415	30	40	40					8	14	22			2.0
6				440-480	50	75	100					5.5	14	14			2.0
7		1.75(105)	6.8	220-230	100	125	150	7	12	17	23	38	60	100	3.5		
8				380-415	30	40	50					8	14	22			2.0
9				440-480	50	75	100					5.5	14	14			2.0
10	750 (748)	1.0(60)	4.6	220-230	100	125	150	5	9	12	16	22	38	60	3.5	990	
11				380-415	20	30	40					5.5	8	14			2.0
12				440-480	50	75	100					5.5	8	14			2.0
13		1.5(90)	6.9	220-230	100	125	150	7	12	17	23	38	60	100	3.5		
14				380-415	30	40	50					8	14	22			2.0
15				440-480	50	75	100					8	14	14			2.0
16		1.75(105)	8.1	220-230	100	125	150	7	12	17	26	38	60	100	3.5		
17				380-415	40	40	50					14	22	22			2.0
18				440-480	50	75	100					8	14	22			2.0
19	1000 (952/1020) [955]	1.0(60)	6.5	220-230	100	125	150	9	16	22	22	38	60	100	3.5	1320 (1260/1350) [1260]	
20				380-415	30	40	40					8	14	22			2.0
21				440-480	50	75	100					5.5	14	14			2.0
22		1.5(90)	9.7	220-230	100	125	150	10	17	24	30	38	100	150	5.5		
23				380-415	40	40	60					14	22	38			3.5
24				440-480	50	75	100					9	16	22			3.5
25		1.75(105)	11.7	220-230	100	125	150	10	17	24	36	60	100	150	5.5		
26				380-415	40	50	75					14	22	38			3.5
27				440-480	50	75	100					14	22	38			3.5
28	1200/1350 (1156/1224/1292) [1160]	1.0(60)	8.3	220-230	100	125	150	8	14	19	27	38	60	100	3.5	1590/1780 (1530/1620/1710) [1530]	
29				380-415	40	40	50					7	12	17			3.5
30				440-480	50	75	100					8	14	19			3.5
31		1.5(90)	13.0	220-230	100	125	150	11	19	26	40	60	100	150(146m) <sup>*2</sup>	5.5		
32				380-415	60	75	11					19	26	40			3.5
33				440-480	50	75	100					14	22	38			3.5
34		1.75(105)	15.0	220-230	100	125	150	12	21	29	45	60	150	150(128m) <sup>*2</sup>	5.5		
35				380-415	60	75	100					22	38	60			3.5
36				440-480	50	75	100					14	22	38			3.5
37	1500/1600 (1496/1564) [1565]	1.0(60)	10.0	220-230	100	125	150	9	16	22	31	38	100	150	5.5	1980/2110 (1980/2070) [2070]	
38				380-415	40	50	60					14	22	38			3.5
39				440-480	50	75	100					8	14	22			3.5
40		1.5(90)	15.0	220-230	100	125	150	12	21	29	45	60	150	150(128m) <sup>*2</sup>	5.5		
41				380-415	60	75	100					22	38	60			3.5
42				440-480	50	75	100					14	22	38			3.5
43		1.75(105)	18.0	220-230	100	125	150	15	26	36	53	100	150	150(109m) <sup>*2</sup>	5.5		
44				380-415	60	75	100					14	24	33			5.5
45				440-480	50	75	100					15	26	36			5.5

Note: Maximum length of lead-in wire is 150m.

\*1 ( ) : For India use only, ( ) : For Malaysia use only.

\*2 Maximum lead-in wire size is 150mm<sup>2</sup>, ( ) : Maximum length of lead-in wire with 150mm<sup>2</sup>.

## ■ Wiring Diagram

— shows the works to be done by others.

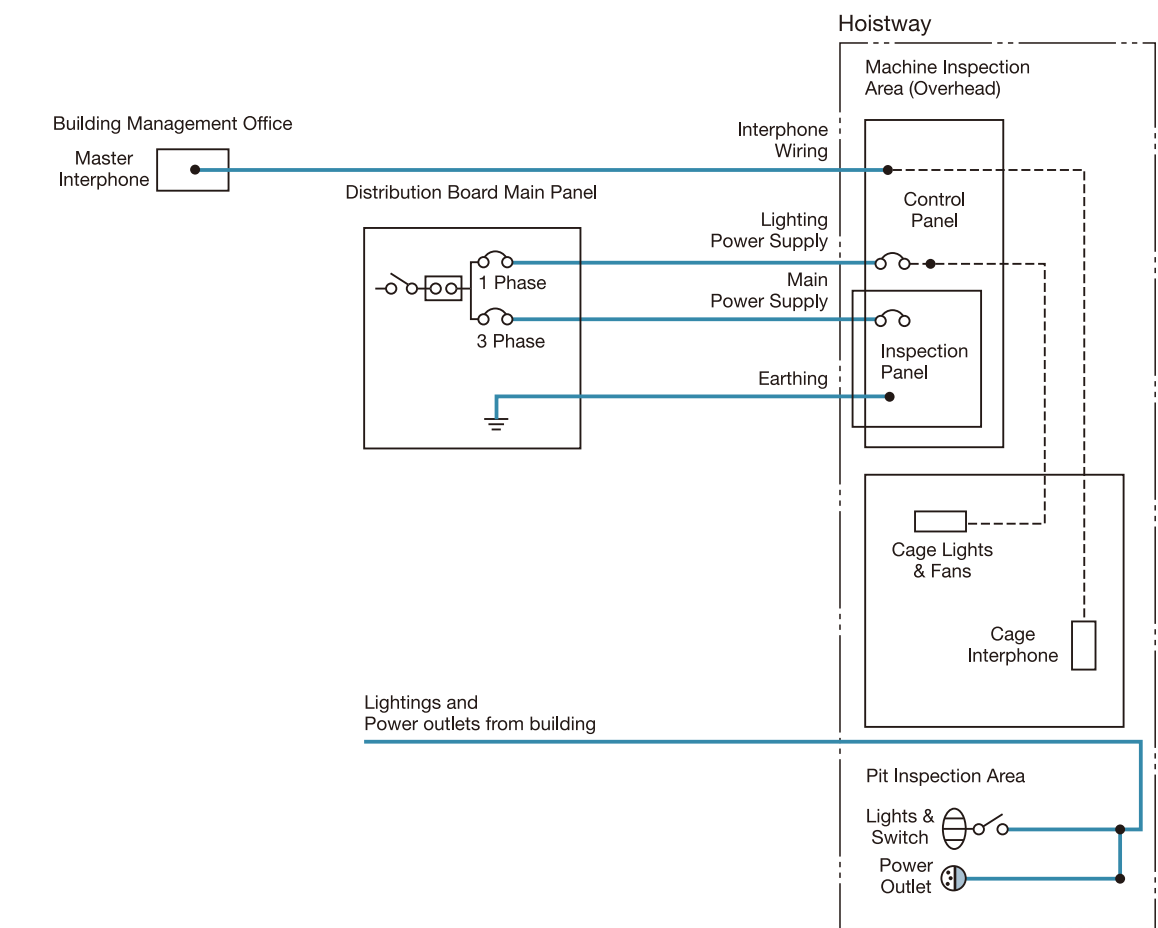

## ■ Work to be provided by other contractors

Item	Works to be provided by others
<b>Main power supply</b> *1	To provide AC 3 phase 200 to 480v 50/60Hz main power supply with maintaining to ensure that the power supply does not fluctuate outside the range of -10% to +10% of the normal voltage rating and to ensure that the unbalance factor of voltage does not exceed 5%.
<b>Lighting power supply</b> *1	To supply and install AC single phase (20Amp) lighting power supply for car lighting, EBOPS and maintenance work.
<b>Interphone</b> *1	To provide piping and wiring (12 wires of 0.9mm <sup>2</sup> /elevator) for interphone located outside the hoistway.
<b>Pit, hoistway lightings &amp; power outlets</b>	To supply and install AC single phase power outlet and lighting with switch located at accessible area from the entrance at bottom landing level for maintenance purpose. Arrange necessary to comply to local code & regulation.

\*1 Main power, lighting power, indicator power supply and interphone wiring shall be led into the hoistway at the highest lifting landing.

Note: In the case that builder provides leak current detector at the side of main power, please use "inverter type" or "detector which does not do unnecessary operation for high frequency".

UAG-SN1