

5230 Walk-in Bathtub CSS90D Value Series

SAFETY TUBS®



The Safety Tubs 52" x 30" Gelcoat walk-in bath provides a similar bathing experience to larger models but fits in smaller spaces and uses less water. The included tub extender allows this tub to retrofit in the same space as a standard bathtub. The full sized, outward opening, contoured door with a low door threshold allows ease of entry and exit.

Fully equipped, the Value Series offers all the latest in safety and comfort features bundled together at one low cost and backed by a lifetime warranty on the door seal, a 10 year warranty on the tub shell and a 5 year warranty on all other components.

WHIRLPOOL MASSAGE



A soothing and invigorating water jet massage system, the Jet Massage features an in-line heater and Legs-Only massage. Customize back and leg muscle therapies with 6 different water jets. The Jet Massage is combined with all of the features of the Soaker Tub providing an enhanced therapeutic bathing experience.

AIR SPA MASSAGE



Experience a soft and caressing all-over body massage powered by a single speed heated blower that releases thousands of air bubbles rising throughout the water from 21 different air jets. The automatic purge cycle helps keep the system running efficient and clean.

The Air Spa is combined with all of the features of the Soaker Tub providing an enhanced therapeutic bathing experience.

COMBINATION SYSTEM



Combines all of the features of the Soaker Tub, the Jet Massage Systems and the Air Massage for the ultimate therapeutic bathing experience.

MINUTE DRAIN® WATER REMOVAL SYSTEM



Spend less time waiting with this patented innovation, that requires no additional plumbing, once activated it rapidly pumps the water out from within the tub-making it safe to open the door and exit the tub. Included in all systems.

SS9OD5230C VALUE SERIES 52" x 30" WALK-IN BATH

SS9OD5230CXS.WH Soaking Tub

- Tub Extender Kit to fill 60" space
- Available in White in Left Hand or Right Hand Door/Drain Configuration
- Outward opening door with watertight door system with a lifetime warranty on the door seal
- Built-in chair height seat
- Polished chrome trim and cable driven waste and overflow
- Built-in safety bar and textured tub floor
- Patented Minute Drain® fast water removal system
- Partial seat transfer
- Premium tub faucet and handheld showering wand

SS9OD5230CXJ.WH Whirlpool Massage System Combines all of the features of the Soaking Tub, plus:

- 6 massage jets with variable flow
- Legs-only massage
- Whirlpool in-line heater

SS9OD5230CXA.WH Air Spa System Combines all of the features of the Soaking Tub, plus:

- 21 seat and floor air injectors
- Single speed heated blower
- Automatic purge cycle

SS9OD5230CXD.WH Combination System Combines all of the features of the Soaker Tub, the Whirlpool Massage and the Air Spa Systems for the ultimate therapeutic bathing experience.

To Be Specified - Required:

- Drain Configuration: Left (L) or Right (R)

Options:

- Handshower Glide Bar: 9HSB
 24 inch Grab Bar: 9GB-24
 Neck Rest: 9NR

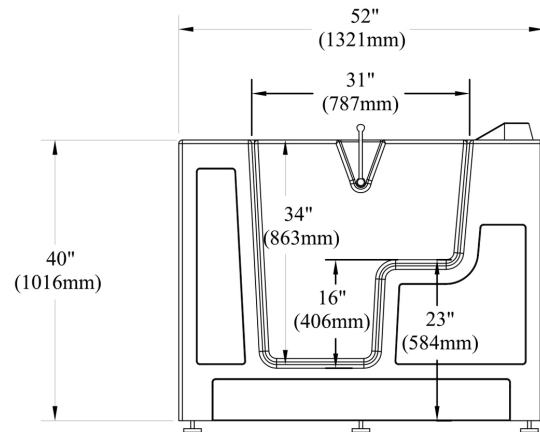
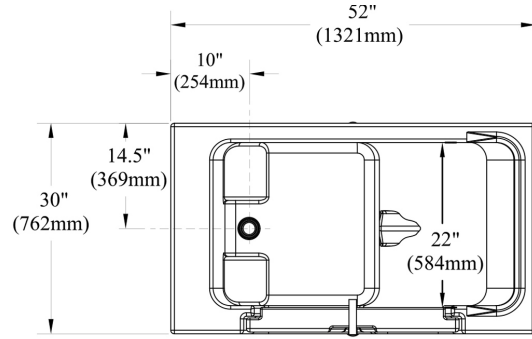

GENERAL SPECIFICATIONS FOR SS9OD5230CXX.WH WALK-IN BATHTUB

INSTALLED SIZE	_____ 52" x 30" x 40" (1320 x 762 x 1016mm)
WEIGHT	_____ 155 lbs (70 Kg)
WEIGHT W/WATER	_____ 781 lbs (354 Kg)
OPERATING GALLON	_____ 75 Gal. (284L)
FLOOR LOADING	_____ 73 lbs/Sq Ft (356 Kg/Sq M)
(PROJECTED AREA) CUBE FT ²	_____ 36.1



Designed for pain relief & easy use

Notes: The whirlpool heater is designed to maintain water temperature during operation. It will not heat cold water to desired bathing temperature. Tub is supported by the frame and five integrated adjustable feet, no additional support required. Refer to installation instructions supplied with tub for additional information. Provide suitable reinforcement to sub floor for all supports.

Our products are in compliance with the following codes: Uniform Plumbing Code UPC®; National Plumbing Code of Canada; International Plumbing Code IPC®

Our products conform to the following standards: ASME A112.19.7, ASME A112.19.15; CSA B45, CSA B45.5; CSA C22.2 No. 218.2; UL-1795; ANSI Z124.1.2

Our products are listed with: c ETL us

IMPORTANT: Dimensions of fixtures are nominal, may vary and are subject to change or cancellation. No responsibility is assumed for use of superseded or voided leaflet.