

PresCal™ HP

Heavy-duty piston-type pressure reducing valves



01026/22.3 NA

Replaces 01226/22.2 NA

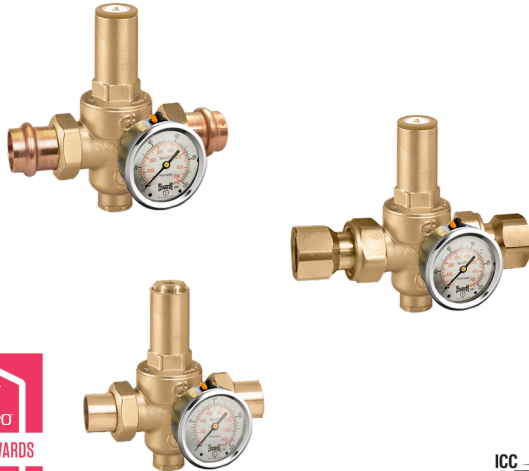

NSF/ANSI/CAN 61 NSF/ANSI/CAN 372

Function

The PresCal™ HP 536A series pressure reducing valve is a high performance true piston-type PRV that can withstand the punishing conditions of water hammer and very high pressure reduction and control. High range models 536x3A, with set point adjustment range 90 to 150 psi, can be used to provide the first stage of pressure reduction in a two-valve series where the pressure ratio between the inlet and outlet would be too high for single PRV to control. Low-range models 536x4A, also a piston PRV, comply with ASSE 1003, have a standard adjustment range of 10 to 90 psi and the all-metal design makes them ideal for outdoor locations and irrigation pressure control.

The valve is constructed of DZR low-lead cast brass and features industry-exclusive true piston operation, without a diaphragm, that ensures stable high pressure control under severe inlet pressure fluctuations and downstream water hammer.

The valve is ICC-ES certified to CSA B356, NSF/ANSI/CAN 61 (180°F/82°C Commercial Hot), NSF/ANSI/CAN 372, low lead laws. It meets codes IPC, IRC, UPC and NPC for use in accordance with the US and Canadian plumbing codes.

Product range

536A series

High performance piston-type pressure reducing valve with pressure gauge and NPT female threaded union connections,
 5360x3A 103 series: 90 to 150 psi high range setting range.....sizes ½", ¾", 1", 1¼", 1½" & 2"
 5360x4A 103 series: 10 to 90 psi low range setting range.....sizes ½", ¾", 1", 1¼", 1½"
 High performance piston-type pressure reducing valve with pressure gauge and press union connections,
 5360x3A 106 series: 90 to 150 psi high range setting range.....sizes ¾", 1", 1¼", 1½" & 2"
 5360x4A 106 series: 10 to 90 psi low range setting range.....sizes ¾", 1", 1¼", 1½"
 High performance piston-type pressure reducing valve with pressure gauge and sweat union connections,
 5360x3A 109 series: 90 to 150 psi high range setting range.....sizes ½", ¾", 1", 1¼", 1½" & 2"
 5360x4A 109 series: 10 to 90 psi low range setting range.....sizes ½", ¾", 1", 1¼", 1½"

Technical specifications

Materials

Body: DZR low-lead cast brass CR EN 1982 CC768S
 Spring case: brass EN 12165 CW617N
 Pressure adjusting screw: brass EN 12165 CW617N
 Closing Cap (5360x4A series only): brass EN 12165 CW617N
 Hexagonal allen key for setting pressure: 10 mm
 Control spindle: stainless steel EN 10088-3 (AISI 303)
 Spring: stainless steel EN 10270-3 (AISI 302)
 Piston: stainless steel EN 10088-3 (AISI 303)
 Piston rings: PTFE
 Moving parts: stainless steel EN 10088-3 (AISI 303)
 Seals: peroxide-cured EPDM
 Strainer: stainless steel EN 10088-2 (AISI 304)
 Seat: stainless steel EN 10088-3 (AISI 303)
 Valve plug: DZR low-lead brass CR EN 12165 CW724R
 Pressure gauge port plug: brass EN 12165 CW617N

Performance

Suitable fluids: water
 Max. pressure upstream:
 5360x3A: 360 psi (2,480 kPa); 5360x4A: 300 psi (2,068 kPa)
 200 psi (13 bar) max. for press connection models
 Downstream pressure setting range:
 5360x3A: 90 - 150 psi (620 - 1,035 kPa)
 5360x4A: 10 - 90 psi (70 - 600 kPa)
 Factory setting:
 5360x3A: 115 psi (800 kPa)
 5360x4A: 45 psi (310 kPa)

Maximum working temperature: 180°F (82°C)
 Flow rates: see graph on page 5
 Pressure gauge scale: 5360x3A: 0 - 200 psi (0 - 1400 kPa)
 5360x4A: 0 - 100 psi (0 - 700 kPa)
 Filter mesh size (diameter): size ½" to 1": 0.2 (0.51 mm)
 size 1¼" to 2": 0.3 (0.65 mm)

Certifications

- Complies with codes IPC, IRC, UPC and NPC. ICC-ES certified to ASSE 1003, CSA B356 (R2015). 5360x4A series only.
- Complies with NSF/ANSI/CAN 61 (180°F/82°C Commercial Hot), as certified by ICC-ES, file PMG-1356.
- Complies with NSF/ANSI 372, Drinking Water System Components- Lead Content Reduction of Lead in Drinking Water Act, California Health and Safety Code 116875 S.3874, Reduction in Drinking Water Act, Vermont Act 193 - The Lead in Plumbing Supplies Law and Maryland's Lead Free Law HB.372, as certified by ICC-ES, file PMG-1360.

Connections

Main connections:
 5360x3A: ½", ¾", 1", 1¼", 1½" & 2"; 5360x4A: ½", ¾", 1", 1¼", 1½"
 NPT female and sweat union
 5360x3A: ¾", 1", 1¼", 1½" & 2"; 5360x4A: ¾", 1", 1¼", 1½"
 press union
 Dual pressure gauge connections: ¼" straight female
 Pressure gauge: ¼" NPT male
 ¼" straight male x ¼" NPT adapter on pressure gauge

Dimensions

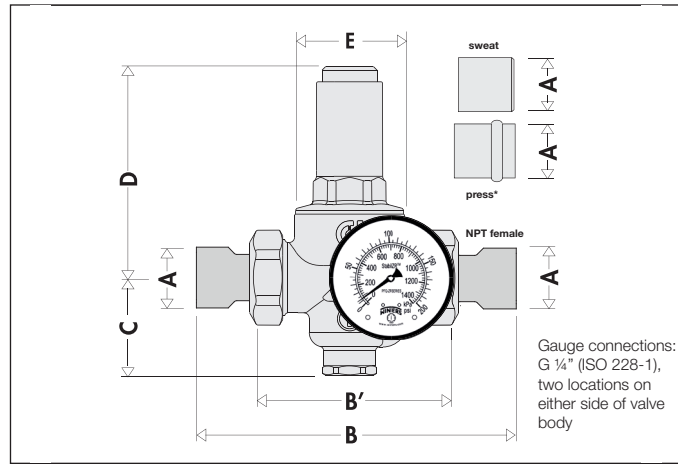

Hi Range Code	Lo Range Code	A	B	B'	C	D	E	Wt. (lb.)
NPT Female threaded connections								
536043A 103	536044A 103	1/2"	5 1/2"	3"	2 1/8"	3 3/8"	2 1/8"	3.3
536053A 103	536054A 103	3/4"	6 1/4"	3 1/2"	2 1/8"	4 9/16"	2 1/8"	4.4
536063A 103	536064A 103	1"	6 7/8"	3 3/4"	2 1/8"	4 9/16"	2 1/8"	5.0
536073A 103	536074A 103	1 1/4"	7 7/8"	4 5/16"	2 1/2"	5 1/4"	2 1/2"	7.5
536083A 103	536084A 103	1 1/2"	8"	4 3/4"	2 1/2"	5 1/4"	2 1/2"	8.8
536093A 103	536094A 103	2"	8 5/16"	5 1/16"	2 1/2"	5 1/4"	2 1/2"	11.2
Press connections								
536053A 106	536054A 106	3/4"	6 3/16"	3 1/2"	2 1/8"	4 9/16"	2 1/8"	4.4
536063A 106	536064A 106	1"	7 3/4"	3 3/4"	2 1/8"	4 9/16"	2 1/8"	5.0
536073A 106	536074A 106	1 1/4"	8 13/16"	4 9/16"	2 1/2"	5 1/4"	2 1/2"	7.5
536083A 106	536084A 106	1 1/2"	12 1/2"	4 3/4"	2 1/2"	5 1/4"	2 1/2"	8.8
536093A 106	536094A 106	2"	13 13/16"	5 1/16"	2 1/2"	5 1/4"	2 1/2"	11.2
Sweat connections								
536043A 109	536044A 109	1/2"	5 5/8"	3"	2 1/8"	3 3/8"	2 1/8"	3.3
536053A 109	536054A 109	3/4"	5 5/16"	3 1/2"	2 1/8"	4 9/16"	2 1/8"	4.4
536063A 109	536064A 109	1"	6 7/8"	3 3/4"	2 1/8"	4 9/16"	2 1/8"	5.0
536073A 109	536074A 109	1 1/4"	6 5/8"	4 5/16"	2 1/2"	5 1/4"	2 1/2"	7.5
536083A 109	536084A 109	1 1/2"	7 3/4"	4 3/4"	2 1/2"	5 1/4"	2 1/2"	8.8
536093A 109	536094A 109	2"	7 15/16"	5 1/16"	2 1/2"	5 1/4"	2 1/2"	11.2

*Lay length
for press:

4 3/16 inch

5 3/4 inch

6 7/8 inch

9 1 1/16 inch

10 1 1/16 inch

Operating principle

Operation of the pressure reducing valve is based on the balance between two opposing forces:

- 1 The force of the spring towards the opening of the valve.
- 2 The force of the metal piston towards the closure of the valve.

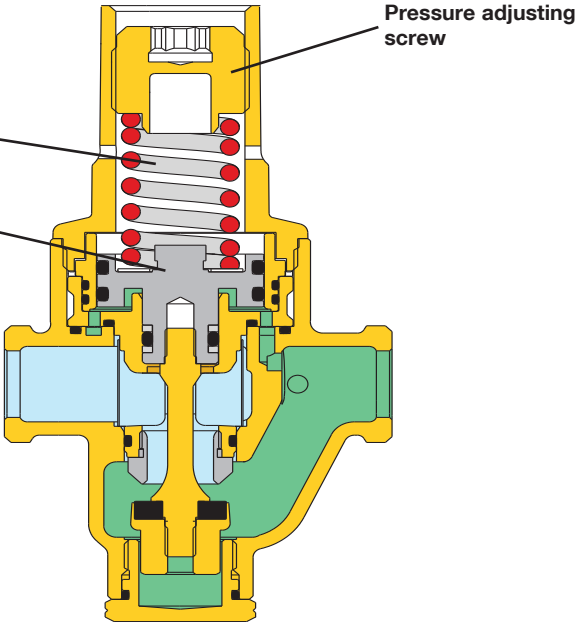

Operation with water flow

When demand is placed on the water system, the force of the spring becomes greater than that of the metal piston; the cartridge moves downwards opening the valve to the flow of water. The greater the demand for water the lower the pressure under the piston with a resulting greater flow of water through the valve.

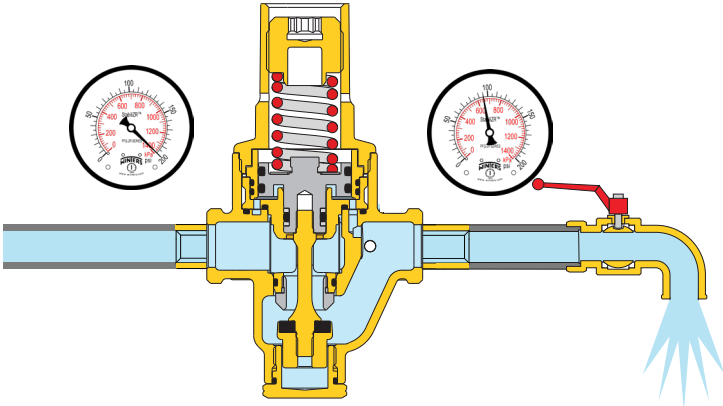

Operation without water flow

When the faucet is closed, the downstream pressure rises and pushes the piston upwards. As a result the cartridge closes the valve to the flow of water and maintains the pressure at the pressure setting. The slight difference between the force of the diaphragm compared to that of the spring causes the valve to close.

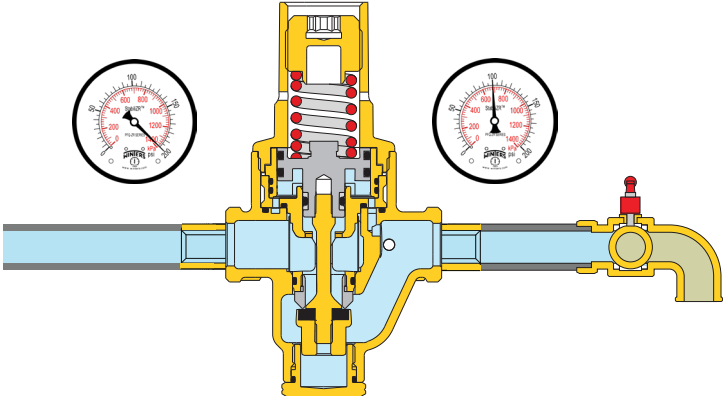

Construction details

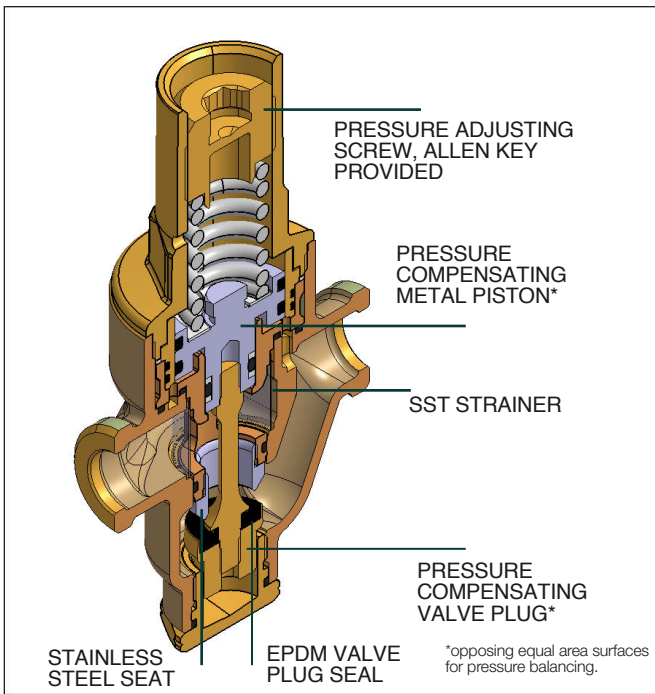

Pressure setting adjustment

Set the desired outlet pressure with the pressure adjusting screw. Turn the screw clockwise with a 10 mm hexagonal Allen key, included, to increase the outlet pressure setting, or counterclockwise to reduce it.

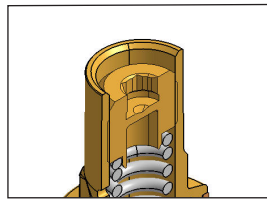

Pressure compensating

Caleffi 536A series pressure reducing valves are designed with pressure compensation between similar sized surface areas of the valve plug versus the metal piston. This ensures precise and constant controlled outlet pressure despite upstream pressure fluctuations. In the figure, the thrust towards the opening is counterbalanced by the force created by the closing pressure acting on the compensating piston. Since the piston has a surface area equal to that of the valve plug, the two forces cancel out each other.

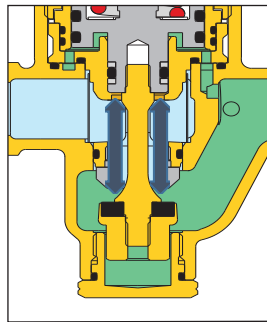

Precision engineering

True metal balancing piston design, with no elastomeric diaphragm, and with PTFE anti-extrusion piston rings provide continuous stable operation at high pressures. The heavy duty piston design withstands punishing water hammer better than diaphragm designs, for long life under severe conditions.



Stainless steel stem and seat

The stainless steel stem and seat minimizes the harmful affects associated with the use of hard and aggressive water.

Removable self-contained cartridge with stainless steel mesh strainer

The cartridge containing the metal piston, strainer, seat, vave plug and stem is a pre-assembled self-contained unit, and can be removed for maximum debris protection, and in-pipe inspection and maintenance. Strainer access is simple for cleaning accumulated dirt and debris, offering added protection in addition to the recommended upstream Y-strainer.

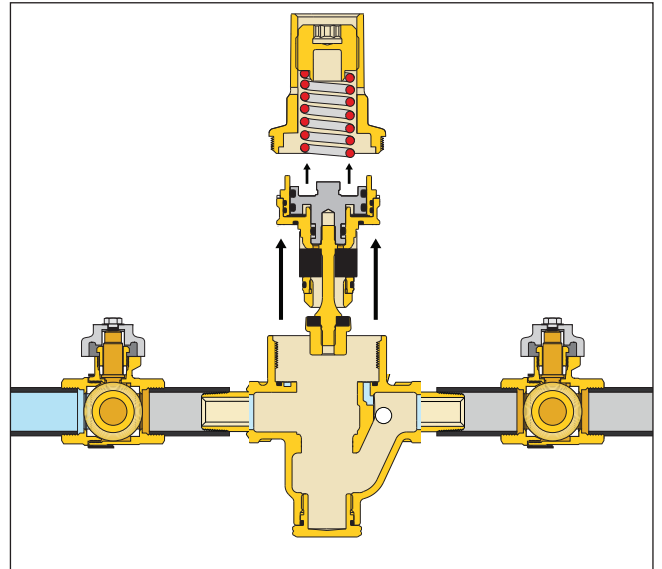

High temperatures

The materials used for the construction of the 536A series pressure reducing valves allow installation also on hot water booster circuits with temperatures up to 180°F (80°C).

Pressure gauge

Furnished with a high quality dual-scale pressure gauge, for installing on either side of the valve body for left-to-right or right-to-left flow orientation, provides a high degree of installation flexibility. This gauge features stabilizer-dampened movement which minimizes the effects of pulsation and vibration.

Do not screw the male NPT gauge directly into the female straight thread port on the valve body; always use the adapter provided.

The pressure gauge shows the exact downstream pressure value regardless of the adjusted knob pressure setting. For special conditions, e.g. in the presence of a downstream water heater, the pressure may rise above the set value.

All metal construction

Allows outdoor installations in mild non-freeze prone regions, perfect for irrigation applications.

Flexible and easy installation

Vertical or horizontal installation. Double unions simplify installation and removal for cleaning/maintenance.

Graph 1 (Maximum velocity for sizing)

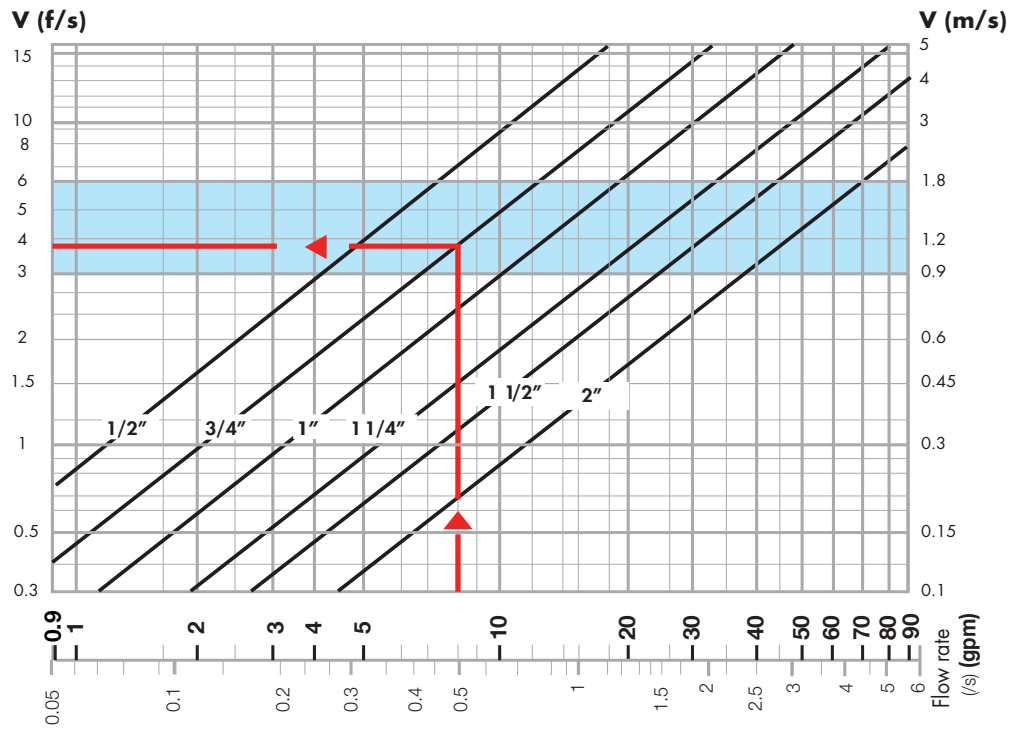

Sizing procedure

Maximum flow velocity is recommended to be kept within 3 to 6 feet per second when calculating the correct pressure reducing valve size. This will prevent noise in the pipes and rapid wear of appliances.

The correct size of the pressure reducing valve is taken from graph 1 on the basis of the design flow rate taking into account an ideal maximum flow velocity in the valve body of between 3 and 6 f/s (blue band).

Example:

For 8 gpm, select the 3/4" size valve (see arrow on graph 1).

Graph 2 (Pressure drop for High Range models)

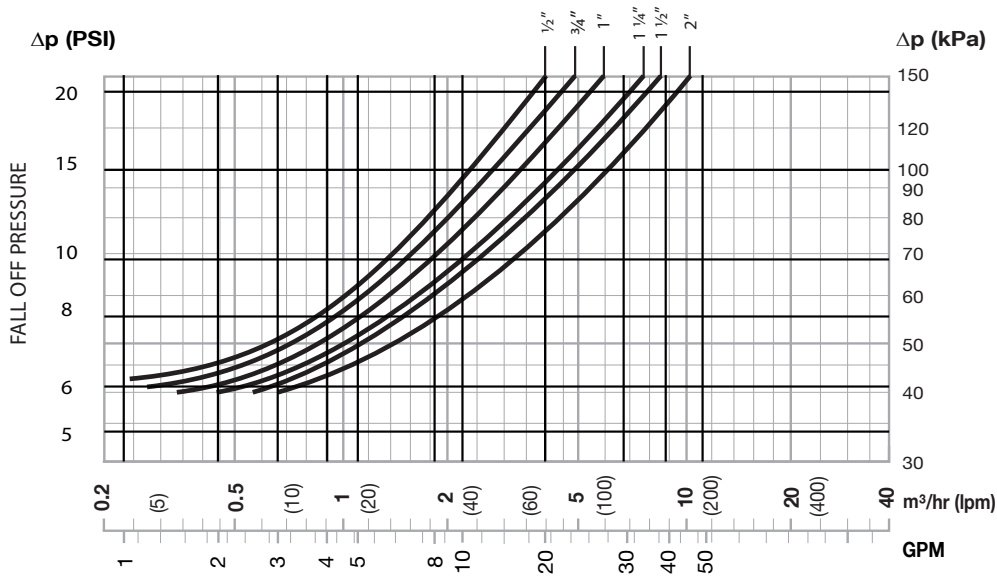

Reference values: Upstream pressure = 232 psi (1,600 kPa)
Downstream pressure = 116 psi (800 kPa)

Graph 3 (Pressure drop for Low Range models)

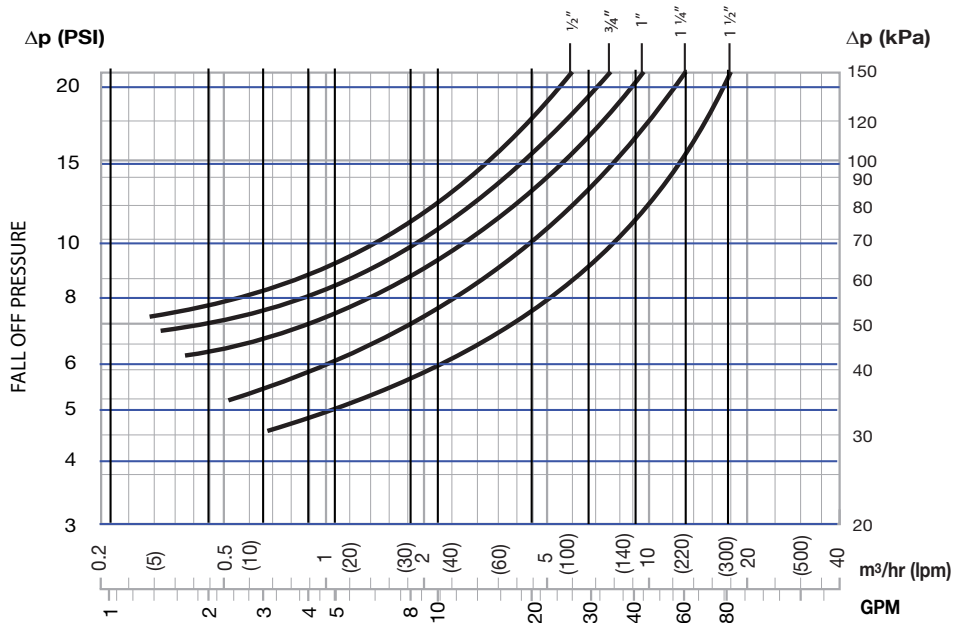

Reference values: Upstream pressure = 116 psi (800 kPa)
Downstream pressure = 43 psi (300 kPa)

Sizing procedure

The pressure drop is taken from graph 2 or 3 where the design flow rate intersects the curve for the valve size already selected for velocity in graph 1 (the downstream pressure falls by an amount equal to the pressure drop, with respect to the set pressure at no flow condition). Make sure the falloff pressure (pressure drop) of the chosen valve, at the specified flow rate, will result in the valve supplying the required pressure to the system fixtures.

Example: For 8 gpm the $\Delta p = 12$ psi (see graph 2), $\Delta p = 10$ psi (see graph 3).

Design Flow Rate (High Range series)						
Size	1/2"	3/4"	1"	1 1/4"	1 1/2"	2"
gpm	4 to 7.3	7 to 12.5	10 to 19	17 to 34	24 to 44	37 to 70
lpm	15 to 27	26 to 47	37 to 72	64 to 129	90 to 166	140 to 265
m³/hr	1 to 1.7	1.6 to 2.9	2.3 to 4.3	3.8 to 7.7	5.4 to 10	8.4 to 16

Design Flow Rate (Low Range series)*					
Size	1/2"	3/4"	1"	1 1/4"	1 1/2"
gpm	5.6	10	16	26	40
lpm	21	38	60	97	150
m³/hr	1.3	2.3	3.6	6.0	9.0

*at 6 ft per second flow velocity

Installation

The pressure reducing valve must be sized in accordance with the system design and the proper selection of the project flow rate to avoid oversizing, or undersizing, causing malfunction. The pressure reducing valve must be installed by a licensed plumber and in accordance with relevant local requirements and following these instructions.

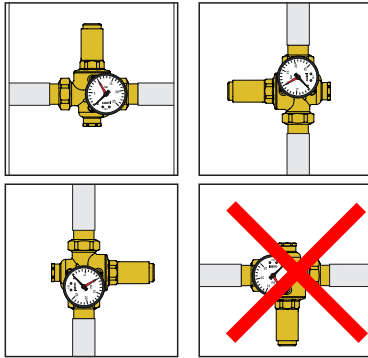

The installer must:

- make sure the reducing valve is compatible with any other equipment in the system it may interact with or come into contact;
- assess and acknowledge all hazards related to the use of the product, including leaks, by installing the unit properly;
- install shut-off valves equipped with pressure ports or similar equipment to measure the upstream pressure.

1) Before installing the pressure reducing valve, open all the outlets to flush the system and purge any air or debris in the piping system.

2) Install shut-off valves upstream and downstream to provide for maintenance.

3) The pressure reducing valve can be installed in either vertical or horizontal pipework. However it must not be installed upside down.

4) The PresCalHP pressure reducing valve comes with a high quality dual-scale pressure gauge, which can be installed in one of two gauge ports on either side of the valve body. These 1/4" straight female threaded ports have factory installed plugs. Remove plug from the desired port and install the pressure gauge with the provided 1/4" straight male x 1/4" npt female adapter, also packaged with the pressure reducing valve and pressure gauge.

5) Close the downstream shut-off valve.

6) Set the desired outlet pressure with the pressure adjusting screw, turning clockwise with a 10 mm hexagonal Allen key, included, to increase the outlet pressure setting, or counterclockwise to reduce it.

Installation recommendations

When installed upstream of a hot water tank, installing an expansion tank or similar is recommended to absorb the increase in pressure due to the thermal expansion of the water. When installed in large buildings, using short pipes, or including expansion valves and similar equipment, will help to limit the increased pressure due to the thermal expansion of the water caused by temperature changes downstream of the reducing valve itself (or downstream of the first and second stage reducing valves, if two are present).

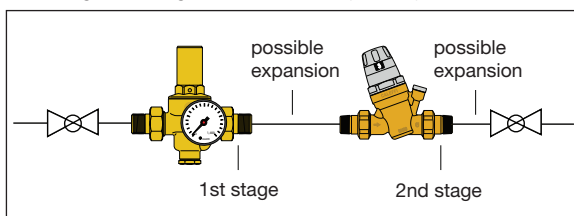
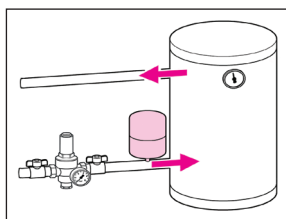

For two-stage pressure reduction, Caleffi recommends using a 536xx3A piston type valve for the 1st stage and a 535H type diaphragm valve for the 2nd stage.

Installation recommendations

To minimize the risk of cavitation within the valve that erode the valve seals, vibrations and noise, the working conditions represented in the below diagram are highly recommended. Due to numerous factors and variable conditions experienced such as system pressure, water temperature, air presence, flow rate and velocity, which may affect the behavior of the pressure reducing valve, the pressure ratio between the upstream pressure and the downstream set pressure should be kept to 2:1 and no greater than a value of 3:1 (For example, upstream 145 psi (1000 kPa), set pressure 72.5 psi (500 kPa), the pressure ratio = $1145/72.5 = 2:1$). Under these conditions, the possible risk of cavitation and malfunction is minimized, however this does not exclude the possible effects of the many other variables within the system under operating conditions. If the pressure ratio exceeds the 2:1 limit, the system design pressure or **use of 1st stage pressure reducing valves** should be reviewed and reconsidered (For example, 1st stage reducing pressure from 240 to 120 psi [1655 to 827 kPa] and then 2nd stage from 120 to 60 psi [827 to 413 kPa]).

Cavitation diagram

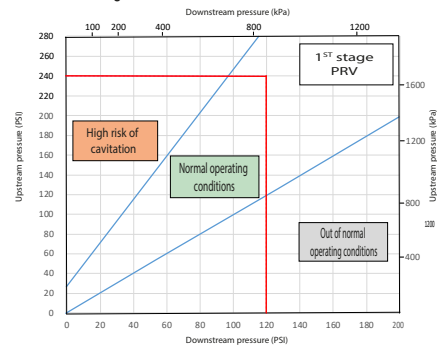

Cavitation diagram

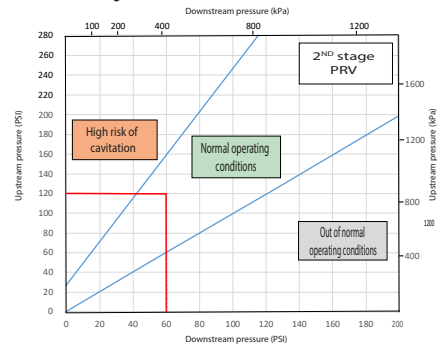

Piping upstream and downstream of the pressure reducing valve must be supported in accordance with the manufacturer's instructions, along with any other local authority requirements, to avoid the creation and transfer of vibration and/or noise into the installation.

The inlet strainer of the pressure reducing valve shall be periodically checked and cleaned, to minimize any partial or complete blockage which may limit the flow rate from the valve and/or create noise.

System flushing, cleaning and disinfection of the piping system in which the valve is installed shall be performed only by qualified personnel in accordance with the system component manufacturer's instructions, along with any other applicable local authority requirements. Exceeding the maximum stated chemical concentrations and/or duration of exposure may negatively impact the performance of the system and/or components installed such as the pressure reducing valve. Chemical dosed products must be chemically compatible to the pressure reducing valve materials of construction, specified in this technical brochure.

Installation below ground

If installing the 536A series PresCalHP pressure reducing valve outdoors or underground, protect the valve from becoming frozen in frost-prone areas.

Allow sufficient space to remove the cartridge to perform required maintenance.

Reading the pressure gauge for setting purposes may be difficult and an alternate means of checking downstream pressure may be necessary.

Application Diagram

Large system with recirculation

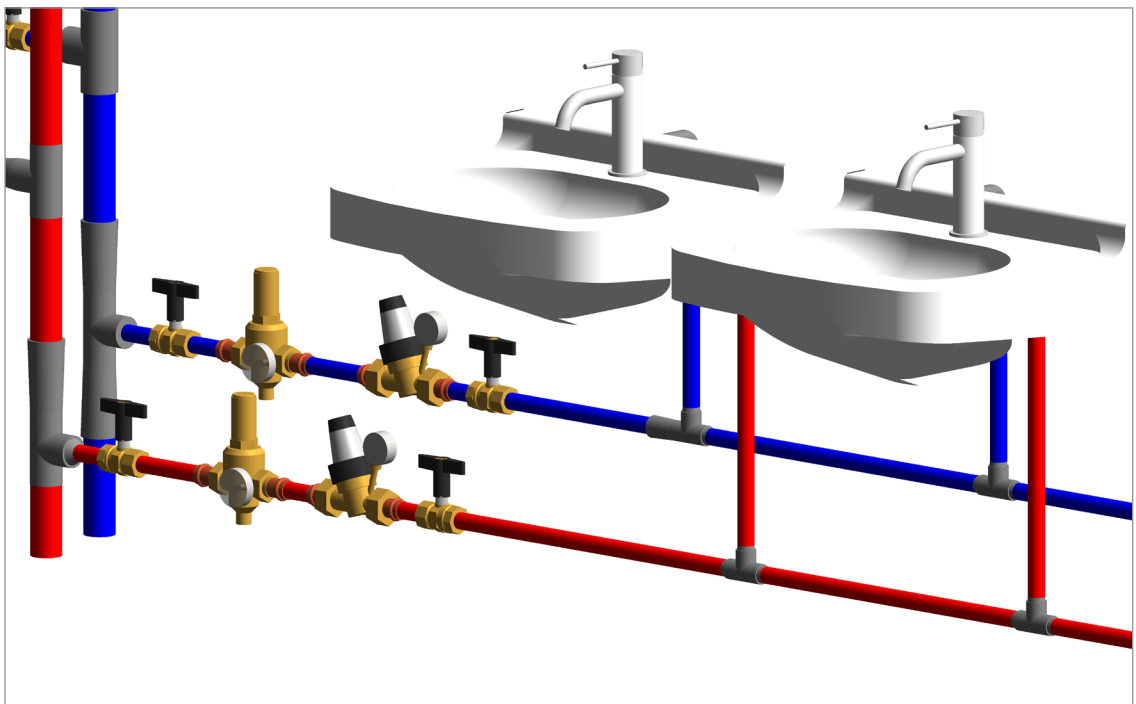
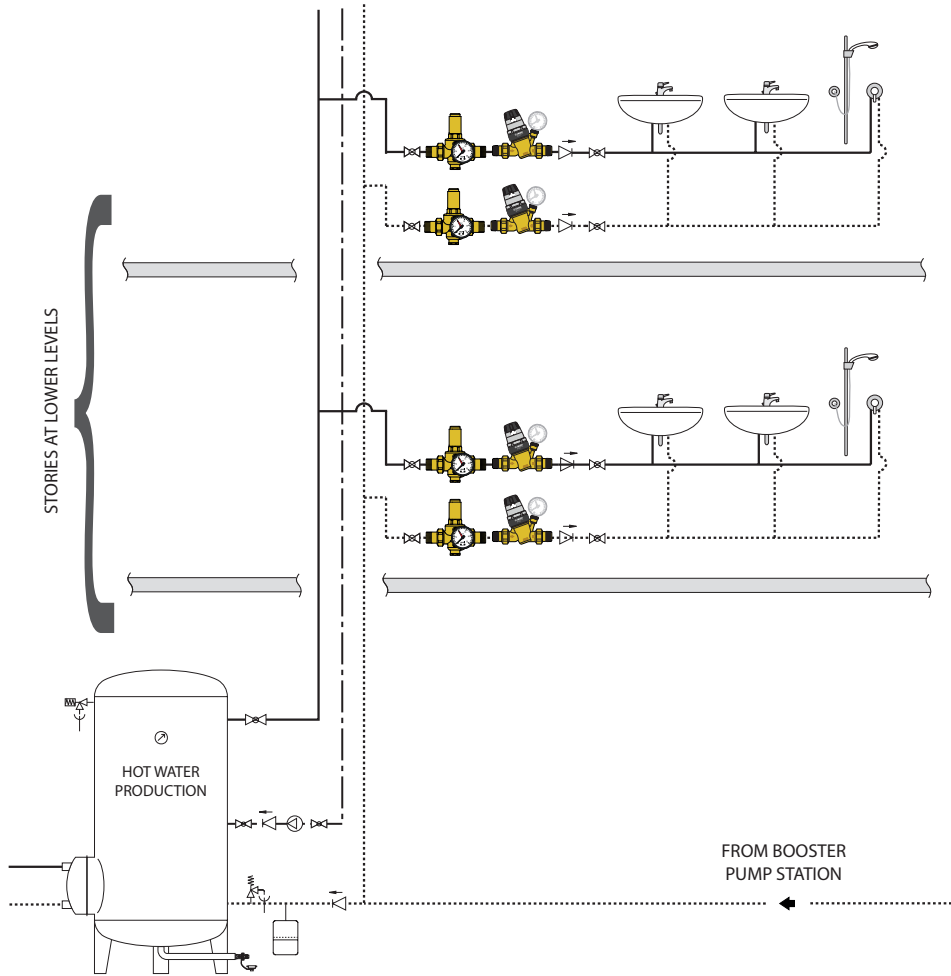

Replacement parts



Pressure gauge
fits 5360x4A series
pressure reducing
valves.

¼" straight female with
¼" NPT male adapter

NA10817.....0 to 100 psi (0 to 700 kPa).



Pressure gauge
fits 5360x3A series
pressure reducing
valves.

¼" straight female with
¼" NPT male adapter

NA10813.....0 to 200 psi (0 to 1400 kPa).



Find us in

MasterSpec[®]

a product of The American Institute of Architects

<https://get.caleffi.info/specpoint>



find BIM Revit files and system templates at
<https://bim.caleffi.com/en-us>

SPECIFICATION SUMMARY

PresCalHP High range 5360x3A series

High performance piston-type pressure reducing valve with pressure compensating piston and valve plug, and self-contained cartridge, certified by ICC-ES to CSA B356, NSF/ANSI/CAN 61 (180°F/82°C Commercial Hot), and NSF/ANSI 372. Meets codes IPC, IRC, UPC and NPC for use in accordance with the US and Canadian plumbing codes. Sizes ½" to 2" with NPT female threaded union or sweat union connections, sizes ½" to 2" press union, sizes ¾" to 2" press union connections. Dezincification resistant (DZR) low-lead cast brass body, CR EN 1982 CC768S (<0.25% Lead content) certified by and listed by ICC-ES. DZR low-lead brass CR EN 12165CW724R valve plug. Brass spring case and pressure adjusting screw, with included 10 mm hexagonal Allen key. Stainless steel AISI 303 control spindle, valve seat and internal moving parts. Stainless steel AISI 302 spring. Stainless steel AISI 304 strainer, mesh size 0.2 (0.51 mm) for size ½" to 1", mesh size 0.3 (0.65 mm) for size 1¼" to 2". Peroxide-cured EPDM seals. PTFE anti-extrusion piston rings. Maximum working temperature 180 degrees F (80 degrees C). Maximum upstream pressure 360 psi (25 bar); 200 psi (13 bar) for press connection models. Downstream pressure setting range from 90 psi to 150 psi (620 - 1035 kPa). Self-contained cartridge removable for maintenance purposes. Dual pressure gauge connections: G ¼" (ISO 228-1), two locations on either side of valve body Equipped with: Brass pressure adjusting screw for tamper-proof manual setting with included 10 mm hexagonal allen key, dual-scale pressure gauge with stabilizer-dampened movement, 0 psi to 200 psi and 0 kPa to 1,400 kPa pressure scale, and brass gauge port plug for unused gauge port.

PresCalHP Low range 5360x4A series

High performance piston-type pressure reducing valve with pressure compensating piston and valve plug, and self-contained cartridge, certified by ICC-ES to CSA B356, NSF/ANSI/CAN 61 (180°F/82°C Commercial Hot), and NSF/ANSI 372. Meets codes IPC, IRC, UPC and NPC for use in accordance with the US and Canadian plumbing codes. Sizes ½" to 2" with NPT female threaded union or sweat union connections, sizes ½" to 1½" press union, sizes ¾" to 1½" press union connections. Dezincification resistant (DZR) low-lead cast brass body, CR EN 1982 CC768S (<0.25% Lead content) certified by and listed by ICC-ES. DZR low-lead brass CR EN 12165CW724R valve plug. Brass spring case and pressure adjusting screw and closing cap, with included 10 mm hexagonal Allen key. Stainless steel AISI 303 control spindle, valve seat and internal moving parts. Stainless steel AISI 302 spring. Stainless steel AISI 304 strainer, mesh size 0.2 (0.51 mm) for size ½" to 1", mesh size 0.3 (0.65 mm) for size 1¼" to 2". Peroxide-cured EPDM seals. PTFE anti-extrusion piston rings. Maximum working temperature 180 degrees F (80 degrees C); . Maximum upstream pressure 300 psi (20 bar); 200 psi (13 bar) for press connection models. Downstream pressure setting range from 10 psi to 90 psi (70 – 600 kPa). Self-contained cartridge removable for maintenance purposes. Dual pressure gauge connections: G ¼" (ISO 228-1), two locations on either side of valve body Equipped with: Brass pressure adjusting screw for tamper-proof manual setting with included 10 mm hexagonal allen key, dual-scale pressure gauge with stabilizer-dampened movement, 0 psi to 100 psi and 0 kPa to 700 kPa pressure scale, and brass gauge port plug for unused gauge port.

We reserve the right to make changes and improvements to the products and related data in this publication, at any time and without prior notice.



Caleffi North America, Inc.
3883 W. Milwaukee Road
Milwaukee, WI 53208
Tel: 414-238-2360 · Fax: 414-238-2366
sales@caleffi.com · www.caleffi.com
© Copyright 2022 Caleffi North America, Inc.