



DELTA

TECK II Concealed Flushometer

83T _____ - _____ series

Write purchase model number here for future reference

210396

210396

210396

210396

210396

210396

210396

210396

210396

210396

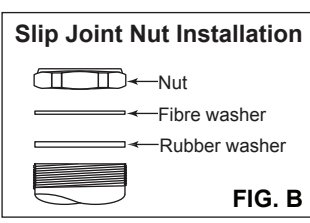
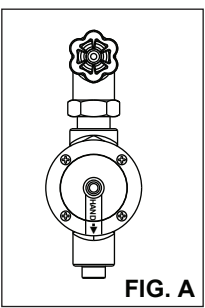
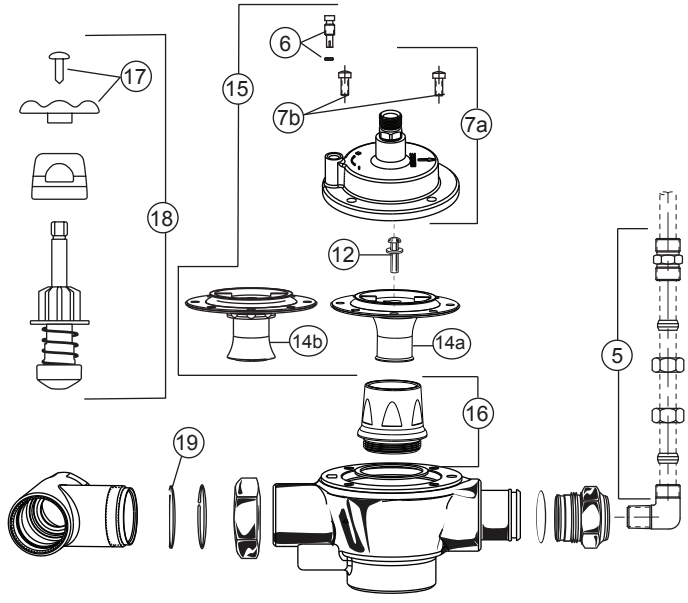
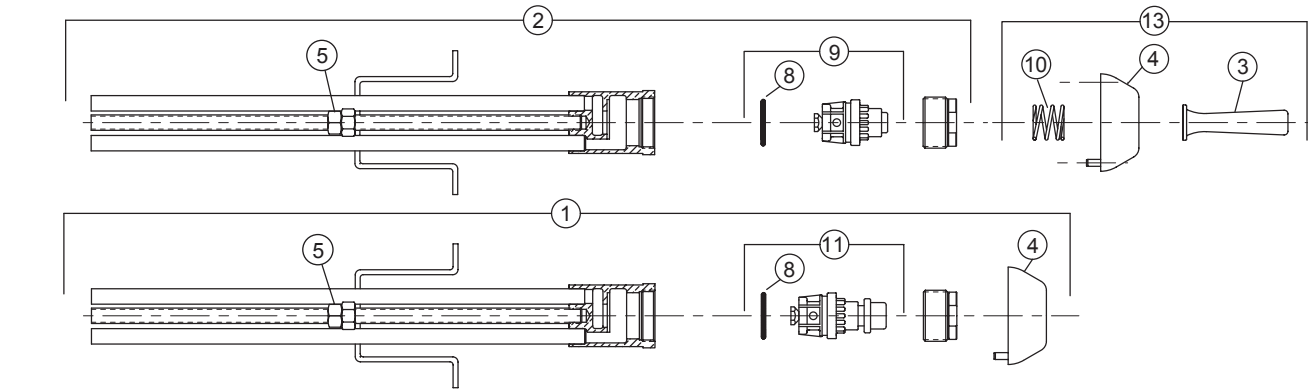

Item #	Part #	Description
	060799A	Universal TECK washers and O-rings repair kit
	061025A	Universal TECK parts washers and O-rings repair kit
1	060822A	Handle control unit complete with 5/8" diameter push button and flange
2	060880A	Handle control unit complete less flange, handle and spring
3	060693A	Handle
4	060756A	Wall flange and pin
5	060712A	Adaptors, compression L nuts and sleeves, locknuts and flange screws package
6	061024A	Regulating screw and O-ring
7a	061238A	Cap sub-assembly and screws
7b	060078A	Screws (12/pkg)
8	060059A	O-rings (12/pkg)
9	060810A	Cage and O-ring assembly
10	060074A	Springs (5/pkg)
11	060755A	5/8" push button cage assembly
12	060508A	Poppet pin (3/pkg)
13	060815A	Oscillating handle & flange assembly
14a	061323A*	Diaphragm guide assembly for Water Closets
14b	061324A*	Diaphragm guide assembly for Urinals
	060079A-MMO	Diaphragm package (12/pkg)
15a	061222A*	Non hold open retrofit kit (includes cap & diaphragm/guide assembly) - WC
15b	061223A*	Non hold open retrofit kit (includes cap & diaphragm/guide assembly) - UR
16	062007A*	Brass seat with O-ring
17	060479A	Handle and screw
18	060845A	Retrofit check stem unit, capnut and handle complete
	060844A	Seat washer, spring, cover and O-ring only
19	060082A	O-rings (20/pkg)
20	060697A	1" copper sweat inlet adaptor
	060694A	3/4" copper sweat inlet adaptor
	060764A	3/4" FIP inlet adaptor
21	060785A	Vacuum breaker sleeve complete
22	060094A	Coupling nut
23	060782A	1-1/2" x 10" V.B., coupling ring and tube complete
24	060778A	1-1/2" rough coupling nut and washers
25	060083A	1-1/2" rubber and fibre slip joint washers
	060049A	3/4" rubber and fibre slip joint washers

* For valves manufactured before January 2013, 062007A brass seat with O-ring must also be replaced when 061323A/061324A diaphragm assembly or 061222A/061223A NHO retrofit kit is replaced.

PLEASE LEAVE this sheet with the owner, maintenance plumber, etc. as items relating to ongoing maintenance suggestions and procedures are included.

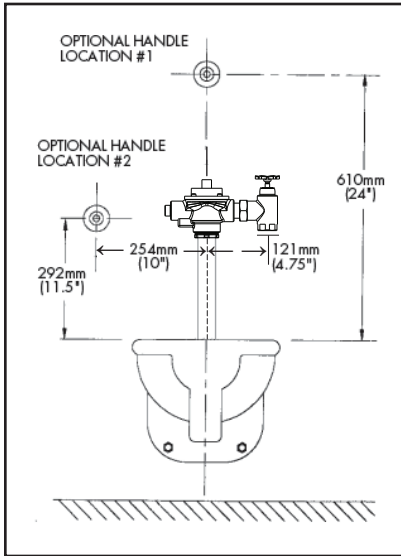

NOTE: Due to excess back pressure of low flow water closets, outlet tubes must be braced to prevent the tubes from disconnecting.

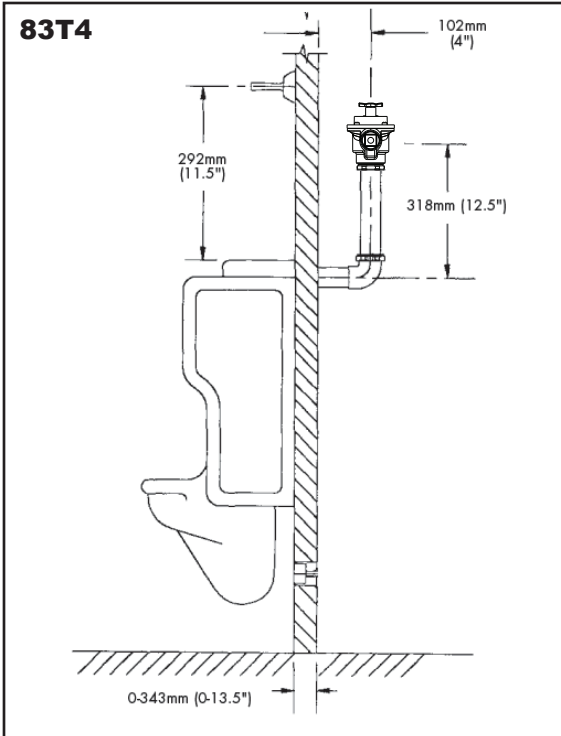
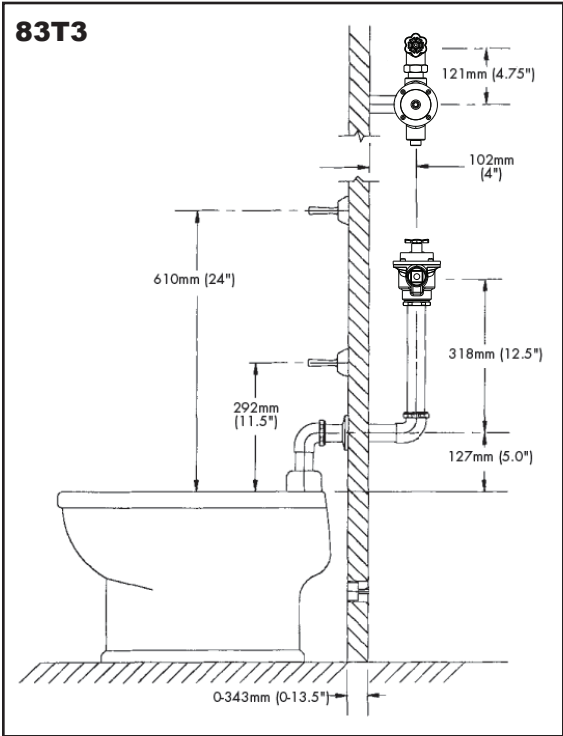
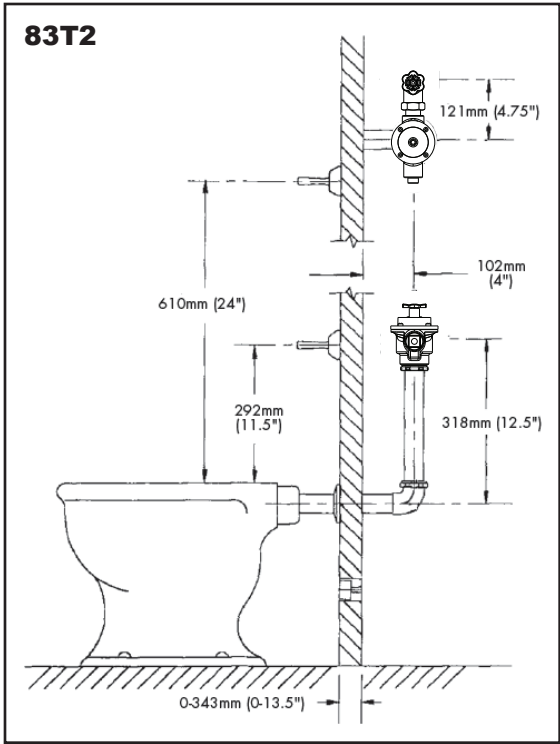
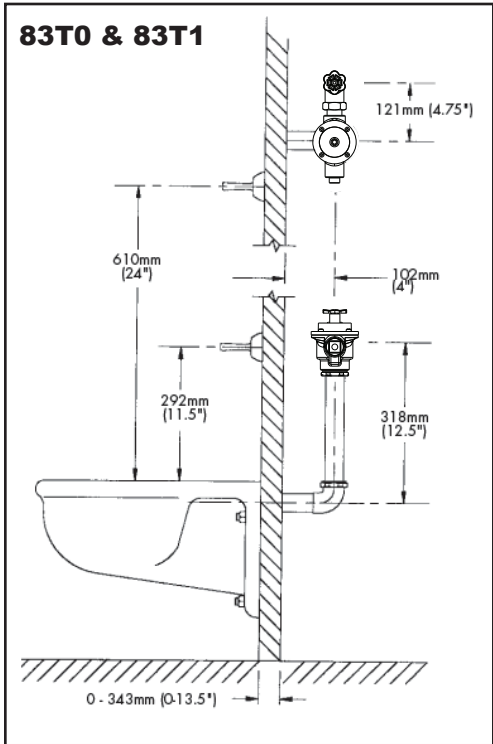

NOTE: Due to excess back pressure of low flow water closets, outlet tubes must be braced to prevent the tubes from disconnecting.

BEFORE THE FIRST FLUSH

FLUSH BOTH OLD AND NEW PIPES:

It is important to FLUSH and CLEAN thoroughly both new and old water piping to ELIMINATE contaminants (i.e., scale, sediment, gravel, cuttings, solder, etc.) from the line. Where the water has a sediment content, a PIPE STRAINER in the supply line should alleviate that condition and protect working parts of flushometers and faucets. On a NEW INSTALLATION, always flush the valve 4 or 5 times to clean out supply line debris. It is also advisable where more than one flushometer is installed on a water line, to flush out the water piping through the last flushometer outlet of the pipe line.

ELIMINATE AIR FROM VALVES:

The FIRST FLUSH should ELIMINATE all air from the TECK flushometer. DO NOT ADJUST flushometer based on the results of the first flush.

FLUSH VOLUME ADJUSTMENT:

- 0.13 U.S. gallons / 0.5 litres for urinal valves.
- 0.5 U.S. gallons / 1.9 litres for urinal valves.
- 1.27 U.S. gallons / 4.8 litres for water conserving closet valves.
- 1.60 U.S. gallons / 6.0 litres for water closet valves.

The regulating screw (061024A, item #6) may be adjusted according to job conditions and fixture installed, to the proper water volume to flush that particular fixture (except -05, -19, -48 and -6 models which are not field adjustable).

NOTE: 4.8 and 6 litre water closets or washdown urinals may require the ANGLE STOP to be SET at only ONE TURN OPEN.

For a SHORTER flush, turn the regulating screw (061024A, item #6) left (counter-clockwise) and right (clockwise) for a LONGER flush (except -05, -19, -48 and -6 models which are not field adjustable).

TO PREVENT WATER HAMMER:

A capped-pipe vertical AIR CHAMBER may be installed at the last flushometer and/or at the back of an individual installation. This assures SMOOTHER OPERATION of the valves and longer life for the working parts.

RECOMMENDED WATER SUPPLY:

WC - minimum flowing pressure: 25 psi (172 kPa), minimum flow rate: 25 gpm (95 lpm)

UR - minimum flowing pressure: 25 psi (172 kPa), minimum flow rate: 8 gpm (30 lpm)

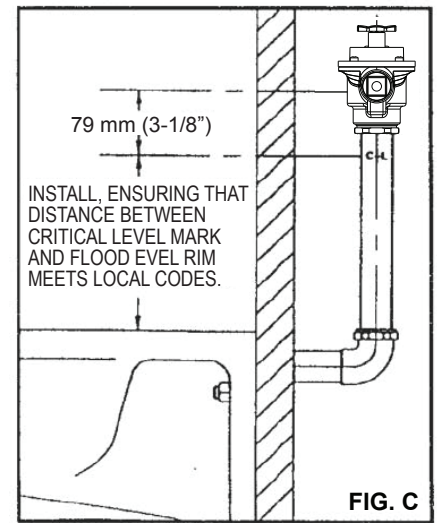

PRISON FIXTURE INSTALLATION

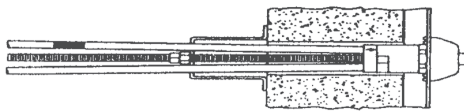

REGULAR INSTALLATION

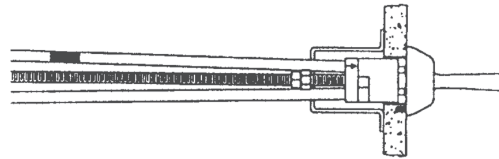

POSITION OF FITTINGS FOR OFFSET HANDLE LOCATION

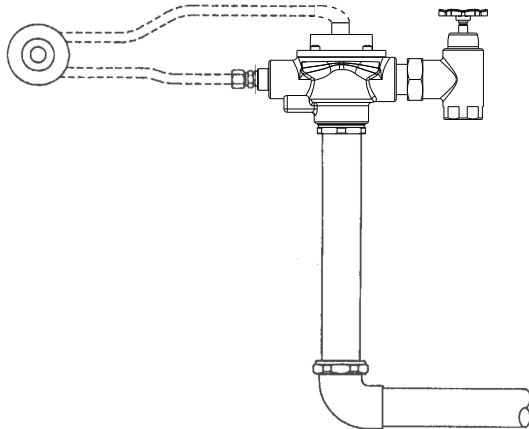

POSITION OF FITTINGS FOR HANDLE ABOVE VALVE LOCATION

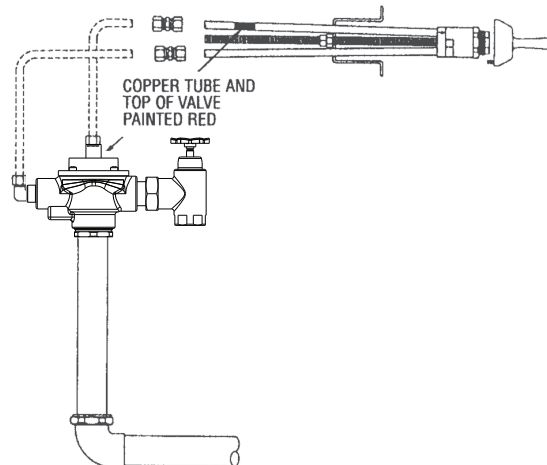

CLEANING INSTRUCTIONS

CLEAN the outside of the chrome-plated flushometer with a damp cloth.

CAUTION: MOST tub and tile fixture cleaners contain ACIDS. DO NOT WIPE the cloth used to clean a ceramic fixture over the exposed chrome-plated parts of the flushometer as it will remove the chrome-plating and leave a discoloured surface.

PROBLEM SOLVING & MAINTENANCE SUGGESTIONS:

NOTE: DO NOT USE EXCESSIVE FORCE to close the inlet stop stem. We RECOMMEND that the flushometer be flushed while closing the inlet stop. The noise created by the water flow or the flow into the fixture will stop when the inlet water is shut off.

NOTE: Always use DELTA COMMERCIAL GENUINE PARTS to maintain the warranty.

EXCESSIVE NOISE:

1. PARTIALLY close the inlet stop.
2. Static pressures OVER 75 PSI may lead to an increase in NOISE, water could SPLASH out of the fixture more easily and the LIFE of any plumbing valve may be SHORTENED.
3. INSTALL a Pressure Reducing Valve set at a lower pressure if actual static pressure is over 75 PSI. Refer to Water Supply section on page 3 for pressure requirements.
4. On flushometers that have been installed for a number of years, check the Seat (061007A, item #16) for wear and replace if necessary.

EXCESSIVE WATER FLOW RATE:

1. OPEN Inlet Stop (060479A, item #17) ONE TURN and adjust Regulating Screw (061024A, item #6) to the fixture requirement (except on -05, -19, -48 and -6 models which are fixed volume).
2. Operation of flushometer with inlet stop BELOW ONE TURN OPEN may cause EXCESSIVE NOISE and PREVENT the non hold open feature from functioning. The lowest open setting for the inlet stop may vary dependent on the installation.

SHORTAGE OF WATER TO PROPERLY FLUSH BOWL:

1. OPEN inlet stop fully.
2. CHECK pipeline for size or obstruction, partially closed gate or other supply line valve, corroded or undersize water piping.
3. CHECK water pressure.
4. Water flow rate is determined by BOTH the water pipe size AND the water pressure available.
5. A water closet flush valve requires a minimum water supply of 1" (or larger), depending on a number of different factors including water pressure (PSI) available, pipe size and length of pipe run, number of fixtures per washroom and per building, fixture type, fixture usage factor, elevation of valve above the water main, etc. We strongly recommend that pipe size calculations be done to insure proper water supply sizes.

Flushometers do NOT provide a water supply; they are merely automatically timed self-closing valves. The inlet supply piping is the water reservoir that must supply sufficient water volume in a short period of time (4 to 10 seconds) to properly flush and clear the fixture.

CONTINUOUS FLUSHING:

1. The Regulating Screw (061024A, item #6) may be turned RIGHT (clockwise) TOO FAR. Adjust by slowly turning the Regulating Screw LEFT (counter-clockwise) (except -05, -19, -48 and -6 models which are fixed volume).
2. If flush is still continuous, close inlet stop, remove Regulating Screw (061024A, item #6), CLEAN bypass slot in the Screw, REPLACE it in the valve and ADJUST slowly for proper flush (except -05, -19, -48 and -6 models which are fixed volume).
3. CHECK the relief valve in the Handle Cage (060810A, item #9 or 060755A, item #11) and see if it is stuck in the open position or fouled by debris. Replace the Handle Cage (060810A, item #9 or 060755A, item #11) if necessary.
4. Remove the Cap assembly and Diaphragm/Guide assembly (061323A - WC or 061324A - UR, item #14) and check for contaminants at Renewable Seat and Diaphragm, and check for debris in the cap for blockage. Also CHECK that the Diaphragm/Guide slides easily in the Renewable Seat.

VALVE WILL NOT FLUSH:

1. When the valve has been taken apart for servicing and re-assembled and does NOT operate, check that the Cap has been put on the body properly. The indicating ARROW labelled "handle" on top of the top cap should point to the handle of the valve (Fig. E).
2. After a number of years, the valve will only flush when the handle is depressed, but shuts off immediately when the handle is released. The Diaphragm (060079A-MMO, item #14) is worn or split and needs replacing.

VALVE WILL NOT REFLUSH:

When the valve flushes once and then will not flush a second time after 10 seconds, CHECK the Handle Cage (060810A, item #9 or 060755A, item #11) for sediment under the seat washer or for a STUCK open relief valve. If necessary, replace the Handle Cage (060810A, item #9 or 060755A, item #11).

SLIGHT WATER LEAK INTO FIXTURE:

1. EXAMINE the seating surface of the Diaphragm (060079A-MMO, item #14) for imbedded sediment.
2. EXAMINE the seat surface of the Handle Cage (060810A, item #9 or 060755A, item #11) seat washer for wear and for sediment under the relief valve. It may be necessary to REPLACE the Handle Cage (060810A, item #9 or 060755A, item #11).

LEAK AT HANDLE:

When the actuator is activated for a flush and there is a LEAK at or around the handle, REPLACE the Handle Cage (060810A, item #9 or 060755A, item #11).

Delta Commercial Faucet Limited Warranty

All parts of the Delta® HDF® and TECK® faucets are warranted to the original consumer purchaser to be free from defects in material, finish and workmanship for a period of five (5) years unless otherwise specifically stated in the catalogue and price book. This warranty is made to the original consumer purchaser and shall be effective from date of purchase as shown on purchaser's receipt.

Delta will, at its option, repair or replace, FREE OF CHARGE, during the warranty period, any part which proves defective in material or workmanship under normal installation, use and water and service conditions. If Delta Faucet concludes that the returned part was manufactured by Delta Faucet and is, in fact, defective, then Delta Faucet will honour the warranty stated herein. Replacement parts can be obtained from your local dealer or distributor listed in the telephone directory or by returning the part along with the purchaser's receipt to our factory, TRANSPORTATION CHARGES PREPAID, at the address listed. THIS WARRANTY IS THE ONLY EXPRESS WARRANTY MADE BY DELTA. ANY CLAIMS MADE UNDER THIS WARRANTY MUST BE MADE DURING THE FIVE YEAR PERIOD REFERRED TO ABOVE. ANY IMPLIED WARRANTIES, INCLUDING THE IMPLIED WARRANTY OF MERCHANTABILITY OF FITNESS FOR A PARTICULAR PURPOSE, ARE LIMITED IN DURATION TO THE DURATION OF THIS WARRANTY. LABOUR CHARGES AND/OR DAMAGE INCURRED IN INSTALLATION, REPAIR OR REPLACEMENT AS WELL AS INCIDENTAL AND CONSEQUENTIAL, SPECIAL, INDIRECT OR PUNITIVE DAMAGES CONNECTED THEREWITH ARE EXCLUDED AND WILL NOT BE PAID BY DELTA FAUCET.

Some states do not allow limitations on how long an implied warranty lasts, or the exclusion or limitation of incidental or consequential damages, so the above limitations or exclusions may not apply to you. This warranty gives you specific legal rights, and you may also have other rights which vary from state to state.

This warranty is for commercial products only from Delta Faucet Company and Delta Faucet Canada (a division of Masco Canada Limited) and is void for any damage to this faucet due to misuse, abuse, neglect, accident, improper installation, any use in violation of instructions furnished by Delta Faucet or any use of replacement parts other than genuine Delta parts.

Garantie commerciale limitée de Delta

Toutes les pièces des robinets de marque Delta™ HDF™ et TECK™ sont garanties contre tout défaut de matériel, de finition et de main-d'oeuvre pour une période de cinq (5) ans, sauf indication contraire stipulée dans le catalogue et la liste des prix. Cette garantie est offerte à l'acheteur original et entre en vigueur à compter de la date d'achat indiquée sur la preuve d'achat.

Delta procédera, à son entière discrétion, à la réparation ou au remplacement, SANS FRAIS, durant la période de garantie, de toute pièce qui présente un défaut de matériel ou de main-d'oeuvre dans des conditions d'installation, d'usure, d'eau et de service normales. Si Delta Faucet détermine que la pièce retournée a été fabriquée par Delta Faucet et qu'en effet, cette pièce est défectueuse, Delta Faucet respectera alors la garantie mentionnée ci-dessous. Les pièces de rechange peuvent être obtenues chez marchand local ou le distributeur inscrit dans votre annuaire téléphonique, ou en retournant la pièce ainsi que la preuve d'achat à notre usine, FRAIS DE TRANSPORT PRÉPAYÉS, à l'adresse indiquée. CETTE GARANTIE EST LA SEULE GARANTIE EXPRESSE FAITE PAR DELTA.

TOUTE RÉCLAMATION FAITE EN VERTU DE CETTE GARANTIE DOIT ÊTRE PRÉSENTÉE DURANT LA PÉRIODE DE CINQ ANS MENTIONNÉE CI-DESSUS. TOUTE GARANTIE IMPLICITE, Y COMPRIS LA GARANTIE IMPLICITE DE VALEUR COMMERCIALE D'ADÉQUATION POUR UN USAGE PARTICULIER, EST LIIMITÉE DANS LE TEMPS À LA DURÉE DE LA PRÉSENTE GARANTIE.

LES FRAIS DE MAIN-D'OEUVRE ET/OU LES DOMMAGES ENCOURUS DURANT L'INSTALLATION, LA RÉPARATION OU LE REMPLACEMENT AINSI QUE LES DOMMAGES ACCIDENTELS ET CONSÉCUTIFS, SPÉCIAUX, INDIRECTS OU PUNITIFS RELIÉS SONT EXCLUS ET NE SERONT PAS PAYÉS PAR DELTA FAUCET.

Certains états ne permettent pas la limitation de la durée de la garantie implicite, ou l'exclusion ou la limitation des dommages accidentels ou consécutifs, et par conséquent, les limitations ou les exclusions stipulées ci-dessus peuvent ne pas s'appliquer dans votre cas. Cette garantie vous accorde certains droits reconnus par la loi et vous pouvez aussi avoir d'autres droits qui varient d'un état à l'autre.

Cette garantie s'applique seulement aux produits commerciaux de Delta Faucet Company et Delta Faucet Canada (une filiale de Masco Canada Limited) et est nulle de plein droit pour tout dommage causé à ce robinet en raison d'une mauvaise utilisation, d'abus, de négligence, d'accident, de mauvaise installation, pour tout usage en contravention des directives fournies par Delta Faucet ou pour tout usage de pièces de rechange autres que des pièces originales Delta.

Garantía Limitada de las Llaves de Agua Comerciales Delta

Todas las piezas de las llaves de agua (grifos) Delta® HDF®, TECK® están garantizadas al comprador consumidor original de estar libres de defectos de material, acabado y fabricación por un periodo de cinco (5) años a menos que sea establecido específicamente de otra manera en el catálogo o libro de precios. Esta garantía se le otorga al comprador consumidor original y será efectiva desde la fecha de compra indicada en el recibo del comprador.

Delta, a su opción, reparará o reemplazará, GRATUITAMENTE, durante el periodo de garantía, cualquier pieza que resulte defectuosa en material o fabricación bajo instalación, uso, agua y condiciones de servicio normales. Si Delta Faucet concluye que la pieza devuelta fue fabricada por Delta Faucet y es, de hecho, defectuosa, entonces Delta Faucet honrará la garantía establecida en este documento.

Las piezas de reemplazo se pueden obtener de su tienda o distribuidor local listado en la guía telefónica o devolviendo la pieza junto con el recibo de compra a nuestra fábrica, CON LOS GASTOS DE ENVÍO PRE-PAGADOS, a la dirección indicada. ESTA GARANTÍA ES LA ÚNICA GARANTÍA EXPRESA HECHA POR DELTA. CUALQUIER RECLAMO HECHO BAJO ESTA GARANTÍA DEBE SER HECHO DURANTE EL PERÍODO DE CINCO AÑOS ARRIBA MENCIONADO. CUALQUIER GARANTÍA IMPLÍCITA, INCLUYENDO LA GARANTÍA IMPLÍCITA DE COMERCIABILIDAD DE EMPLEO PARA UN PROPÓSITO PARTICULAR, TIENE UNA DURACIÓN LIMITADA A LA DURACIÓN DE ESTA GARANTÍA. LOS CARGOS DE MANO DE OBRA Y/O DAÑO INCURRIDO DURANTE LA INSTALACIÓN, REPARACIÓN O REEMPLAZO, COMO TAMBIÉN DAÑOS INCIDENTALES O RESULTANTES, ESPECIALES, INDIRECTOS O PUNITIVOS RELACIONADOS CON LO MENCIONADO, QUEDAN EXCLUIDOS Y NO SERÁN CUBIERTOS POR DELTA FAUCET.

Algunos estados no permiten limitaciones de la duración de una garantía implícita, o la exclusión o limitación de daños incidentales o consecuentes, de manera que las limitaciones o exclusiones arriba mencionadas puedan no aplicarse en su caso. Esta garantía le otorga derechos legales específicos, y usted también puede tener otros derechos que varían de estado a estado.

Esta garantía es solo para productos comerciales de Delta Faucet Company y Delta Faucet Canada (una división de Masco Canada Limited), y queda anulada por cualquier daño ocasionado a esta llave de agua resultante del mal uso, abuso, descuido, accidente, instalación incorrecta, cualquier uso en violación de las instrucciones proporcionadas por Delta Faucet o el uso de cualquier parte de repuesto que no sea una parte genuina de Delta.

Delta Faucet Canada, a division of Masco Canada Limited
350 South Edgeware Road, St. Thomas, Ontario, N5P 4L1
1-800-567-3300 (English) 1-800-265-9245 (French)

Delta Faucet Company
Box 40980, 55 East 111th St., Indianapolis, IN, U.S.A. 46280
(317) 848-1812

For further technical assistance, call Delta Commercial Technical Service at 1-800-387-8277 (Canada) or 1-877-509-2680 (U.S.A.).
Pour obtenir de l'assistance technique, appelez le Service Technique de Delta Commercial au 1-800-387-8277 (Canada) ou 1-877-509-2680 (U.S.A.).
Por la asistencia técnica adicional, llame al servicio técnico de Delta Comercial al 1-800-387-8277 (Canada) o 1-877-509-2680 (U.S.A.).