

SPECIFICATION: (EXAMPLE)

(FOR 1-1/2" BACK INLET CLOSET FIXTURE)

- Quiet action, TECK® exposed diaphragm flush valve
- Chloramine resistant diaphragm
- Forged brass diaphragm retainer
- Renewable seat
- Polished chrome-plated body
- **External water conserving flush volume adjustment,** (except -48 and -6 models) factory set to 6 litre (1.6 gal.)
- Vandal resistant cover screw
- Metal "non hold open" handle
- **1" FIP/copper sweat inlet adaptor** angle check stop with protecting cap
- Adjustable 121mm (4-3/4") plus or minus 11mm (7/16") inlet/valve outlet centers
- Vacuum breaker
- Cover tube and S/S wall flange, spud flange and concealed spud nut
- **Recommended water supply:**
Minimum flowing pressure – 25 psi (172 kPa)
Minimum flow rate – 25 gpm (95 L/min)

□ **81T271**
As above

81T271

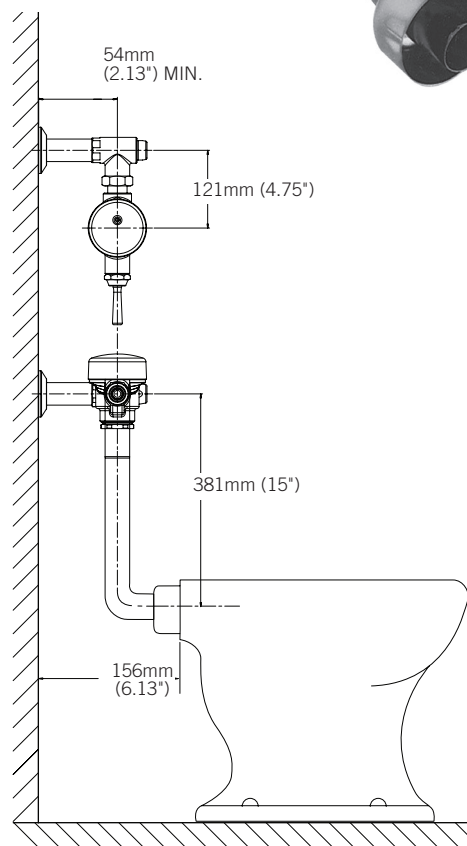

APPROVALS:

- IAPMO listed to ASSE 1037/ ASME A112.1037/CSA B125.37
 - Indicates compliance to ICC/ANSI A117.1
- (Contact Delta Representative for State and/or Local Approvals.)

Engineer/Architect Approval	
Model Specified:	
Approval:	Date:

Note: Measurements may vary ± 6mm (0.25")

Note: For high and low pressure applications, please see page FEA-81T High Water Pressure note for more details. Verify flow requirements with bowl manufacturer.