Mounting and care instructions

Notice de montage et d'entretien

Instrucciones de montaje y conservación

Pressure Balance Bath & Shower Trims

Dispositifs de régulation de pression pour
douche et baignoire

Embellecedores para ajustar la presión en
bañera y ducha

For the following models:

Pour les modèles suivants :

Para los siguientes modelos:

CE5290012UXX

DS5290011UXX

N05290012UXX

XX Color Codes:

Codes couleur XX :





Códigos de color XX:

10 - Chrome





37 - Brushed Gold

46 - Matte Black

70 - Brushed Nickel

	Important information	4
	Installation	5
	Operation	10
	Care & maintenance	11

	Remarques importantes	13
	Montage	14
	Commande	19
	Entretien & maintenance	20

	Información importante	22
	Montaje	23
	Manejo	28
	Conservación y mantenimiento	29



These instructions are part of the Duravit product and must be read carefully and kept available at all times.

Target readership and qualifications

The product may only be installed by a qualified plumber.

Explanation of the key words

CAUTION

Indicates a hazardous situation which, if not avoided, could result in minor or moderate injury.

NOTICE

Addresses practices not related to physical injury.



This unit meets or exceeds the following:

- ASME A112.18.1
- CSA B125.1
- ADA Compliant

Safety instructions

Cut and crush injuries

- > Wear gloves when installing the product.

Product and/or property damage

- > Observe the local installation regulations and any country-specific standards at all times.
- > Equalise pressure differences between cold and hot water connections.
- > Observe the manufacturer's instructions for installation with continuous flow heaters.

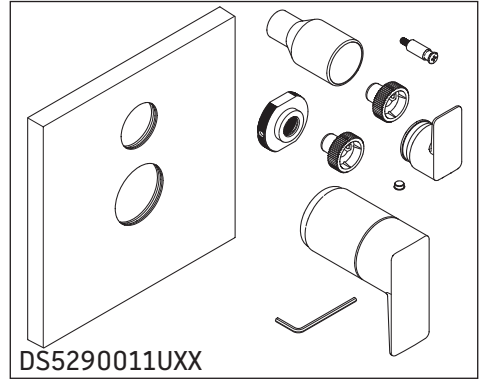
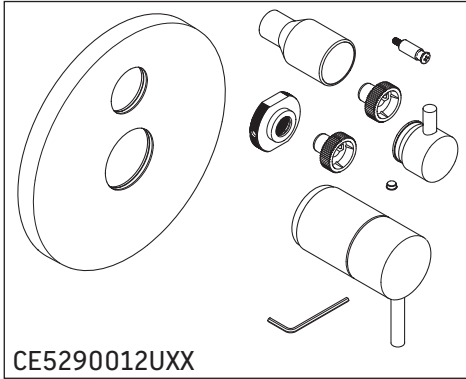

en

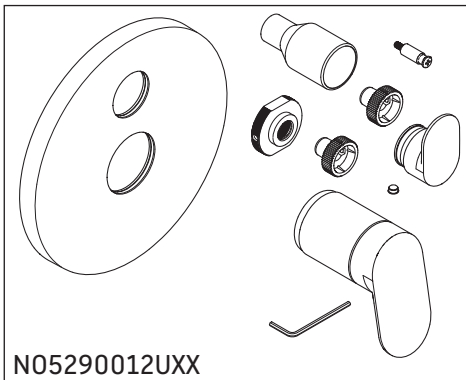

NOTE:

GK0900011U00 Pressure Balance Valve is required to be installed before the trim.

Illustrations may differ from actual product.



en

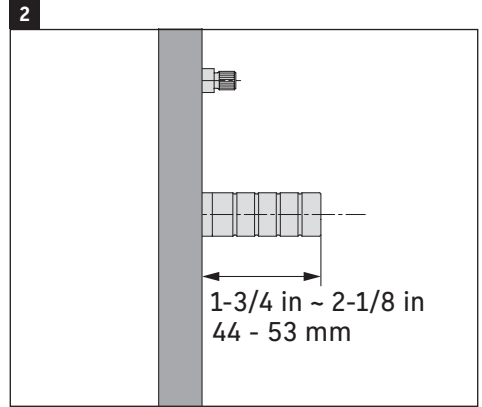
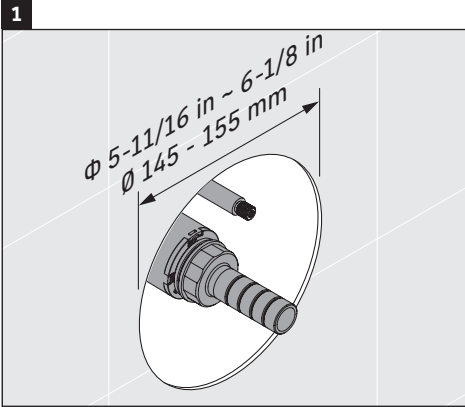

NOTICE

> Wall opening range should be between Φ 5-11/16 in ~ 6-1/8 in (Φ 145 mm - 155 mm).

> The distance between the finished wall and threaded rod should be between 1-3/4 in - 2-1/8 in (44 - 53 mm). If more than 2-1/8 in, you will need to cut the threaded rod.

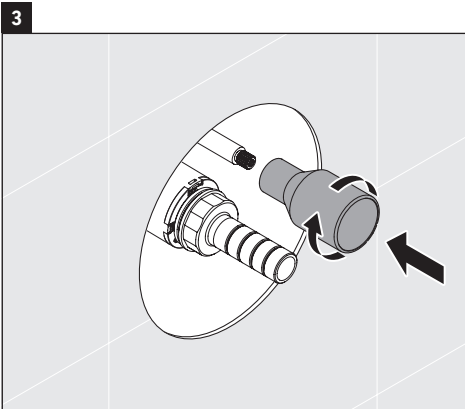

> Mount the sleeve by turning clockwise onto valve.

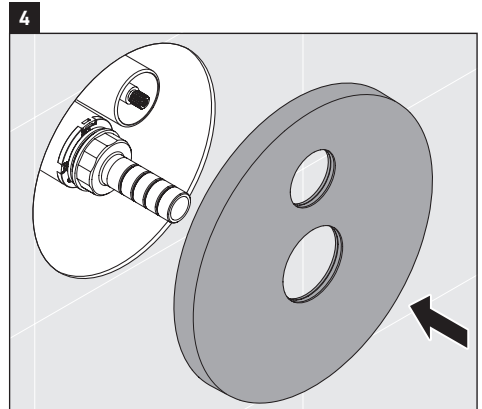

> Mount the trim plate.



5

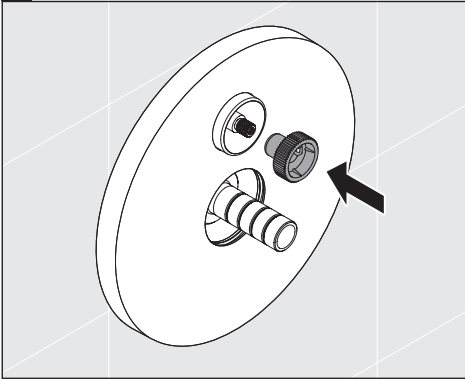

> Mount spline adapter by fitting together, teeth to teeth.

6

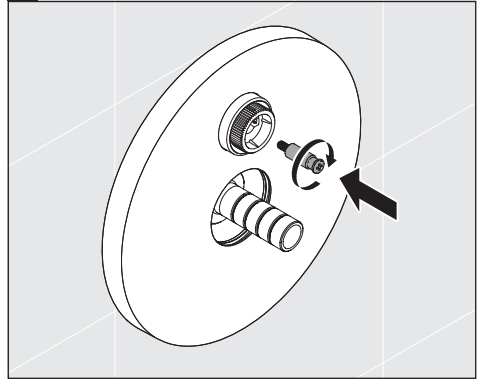

> Install the screw by turning clockwise onto the valve shaft.

7

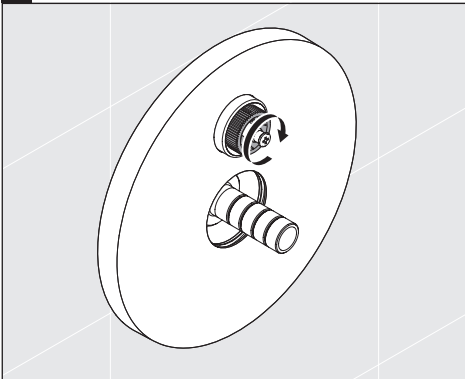

> Turn the spline adapter until tight.

NOTICE

> Do not overtighten.

8

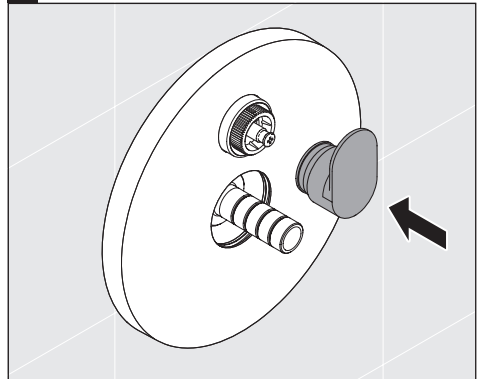

> Position the handle upwards, then install the handle set with spline adapter teeth to teeth.

en



en

9

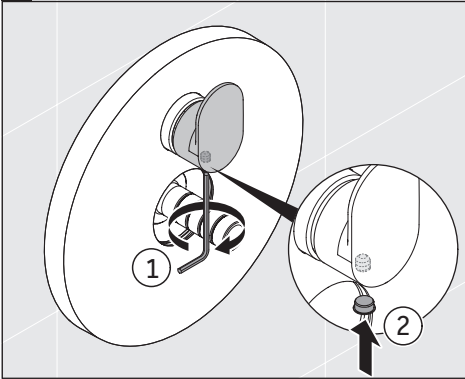

- > Use an Allen key to turn the screw on the side of diverter handle. Do not overtighten.
- > Place the plug into the diverter handle.

10

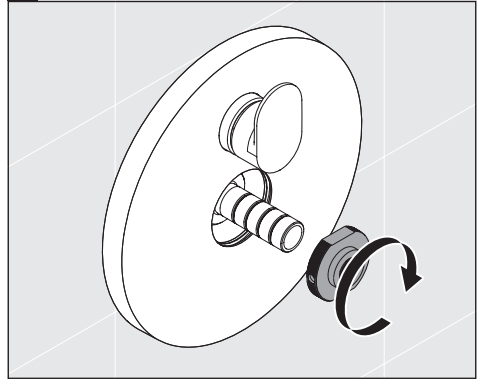

- > Place the joint onto the shaft rod of the valve and turn clockwise. Tighten until it stops.

11

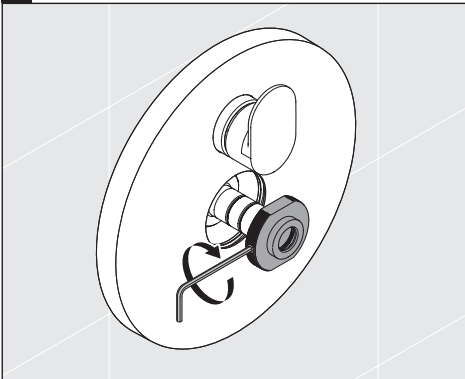

- > **Tighten the set screw using the Allen wrench.**

CAUTION

- > Do not cross thread.

12

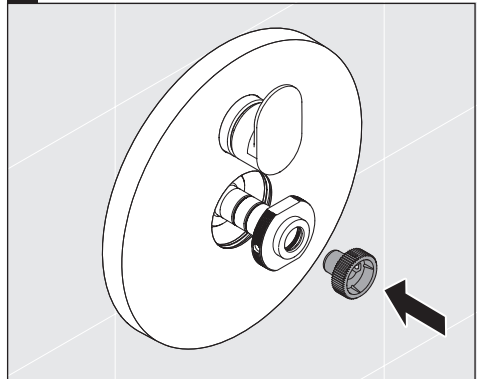

- > Install the spline adapter teeth to teeth.



13

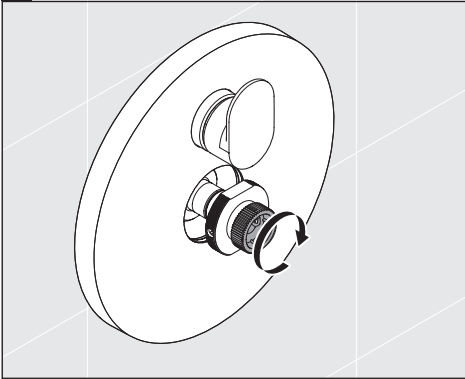

- > Turn the spline adapter clockwise until tight.

NOTICE

- > Do not overtighten.

15

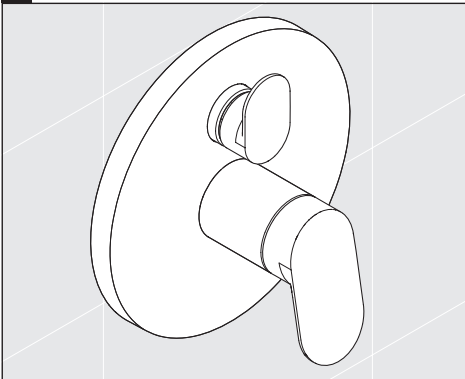

- > Installation complete.

14

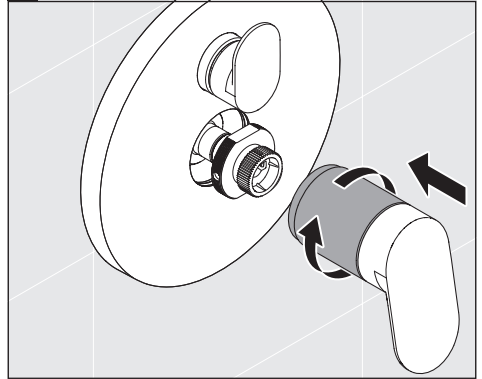

- > **Put the handle in the downward position** and install the handle set to the spline adapter teeth to teeth.
- > Turn the handle sleeve clockwise until it's against the trim tightly.

CAUTION

- > Do not overtighten. If handle seems too tight, loosen the handle sleeve slightly.

en



en

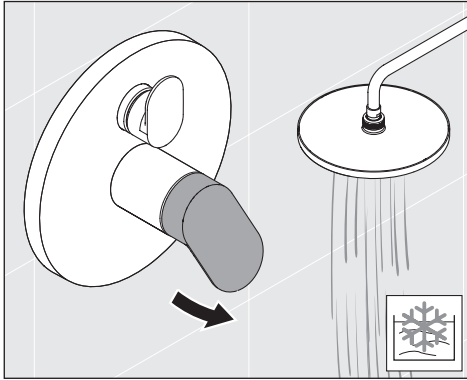

> Move the handle counterclockwise to turn the shower on

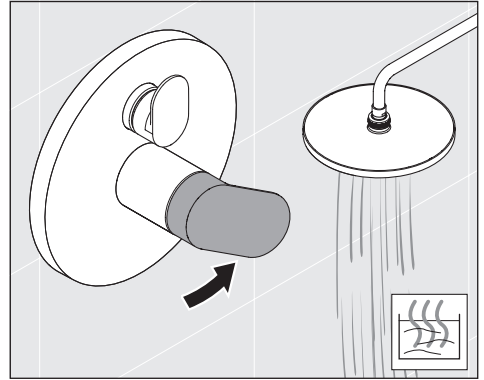

> Move the handle counterclockwise to go from cold to hot

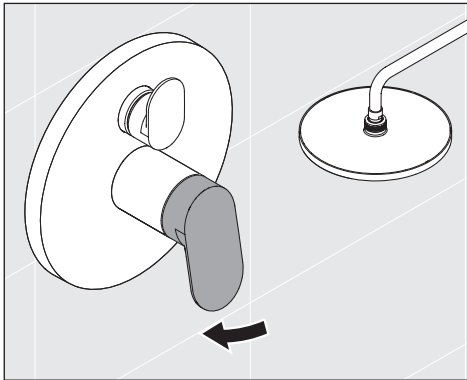

> Turn off the shower by moving the handle clockwise to the starting position.

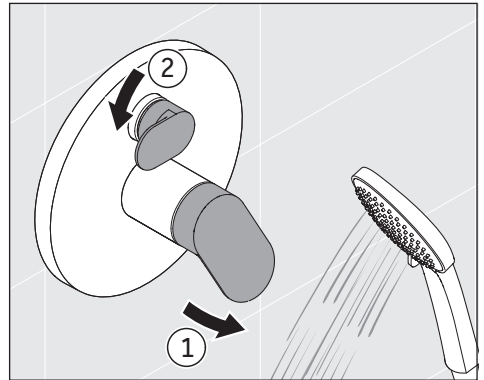

> To divert function from shower to hand shower or tub spout, turn the diverter handle counterclockwise.

**Chemical/Cleaners to avoid:**

- Abrasives and polishes, including bleach based cleaners
- Scrubbing bubbles and Lysol basin tub
- Soft scrub, tile cleaner and Windex original
- Fantastic antibacterial heavy duty and comet bathroom cleaner
- Products containing hydrofluoric
- Hydrochloric and/or phosphoric acids
- Anything with caustic agents
- Anything with ammonia, bleach or acid

Chemical/Cleaners recommended:

Mild cleaner (ph7) based on citric acid.

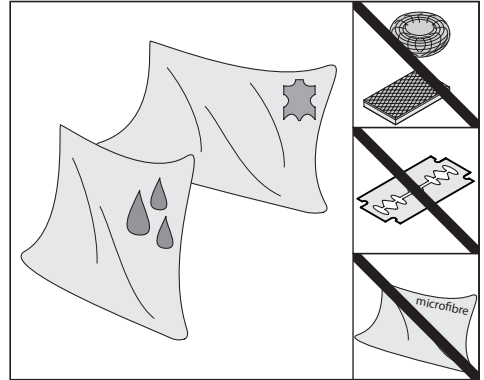
**Cleaning tools to avoid:**

- Abrasive cleaning pads
- Scraping tools
- Abrasive cleaning tools

Cleaning tools recommended:

- Moistened soft cloth
- Leather cloth



en

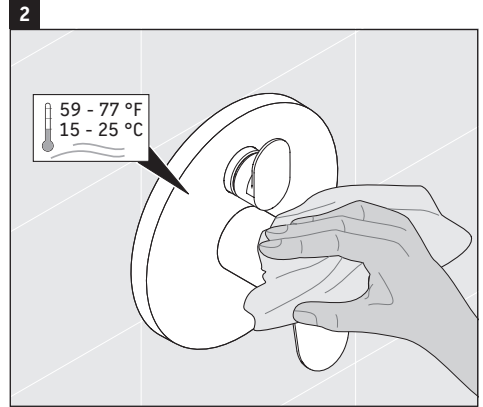
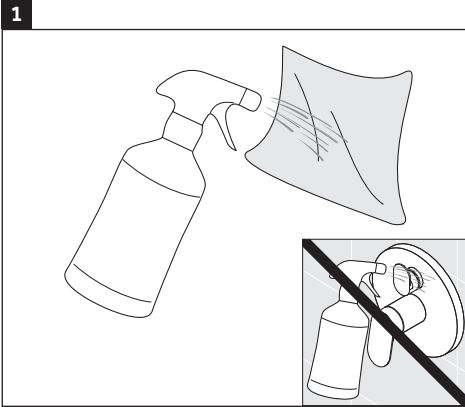

NOTICE

Spray mist can ingress and cause damage to the faucets and fittings

> Spray cleaner onto a cleaning cloth, not directly onto the product.

> To protect the finish, temperature should not exceed 77 °F.

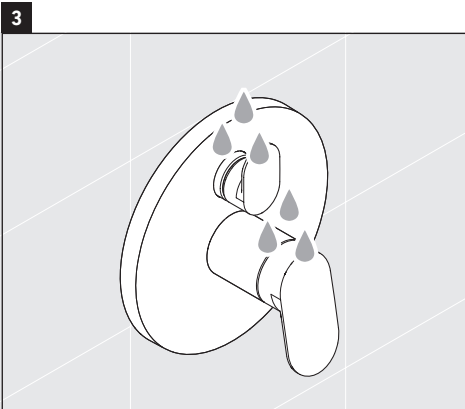

> Rinse with water.

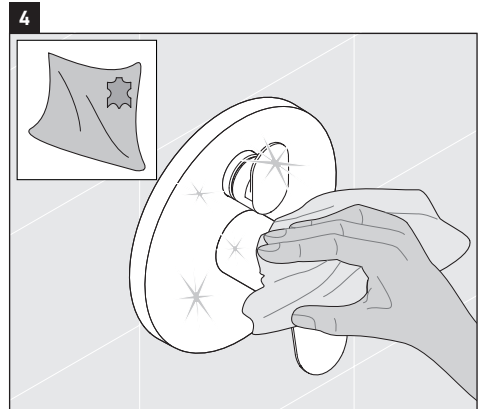

> Dry with a clean cloth.



Ces instructions font partie du produit Duravit et doivent être lues attentivement et conservées en tout temps.

Lectorat ciblé et compétences

Le produit peut seulement être installé par un plombier compétent.

Explication des mots-clés

MISE EN GARDE Indique une situation dangereuse qui, si elle n'est pas évitée, entraînera des blessures mineures ou moyennes.

ATTENTION Répond à des pratiques qui ne sont pas reliées aux blessures physiques.



Cette unité répond ou dépasse ce qui suit :

- ASME A112.18.1
- CSA B125.1
- Conforme avec ADA

Instructions sur la sécurité

Blessures et coupures

- > Portez des gants lorsque vous installez le produit.

Endommagement d'un produit et/ou d'une propriété

- > Observez les règlements d'installation locaux et les normes nationales particulières en tout temps.
- > Égalisez les différences de pression entre les raccordements d'eau froide et chaude.
- > Suivez les instructions du fabricant pour l'installation avec des chauffe-eau sans réservoir.

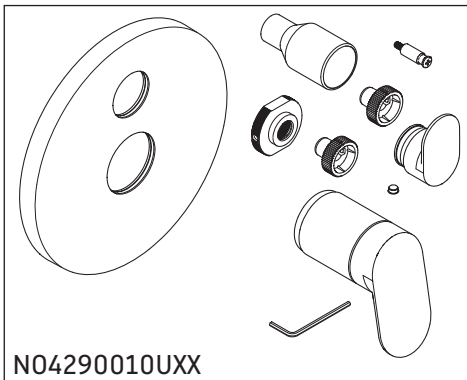
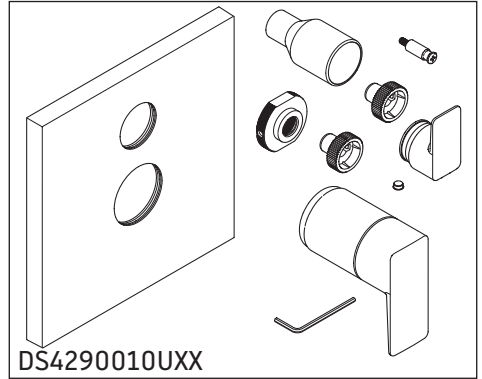
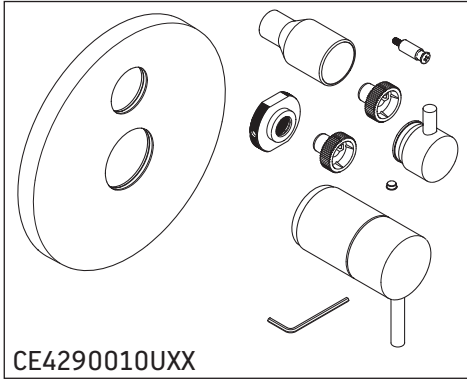

REMARQUE :

La vanne de régulation de pression GK0900011U00 doit être installée avant le dispositif.

Les illustrations peuvent s'écarter du produit réel.

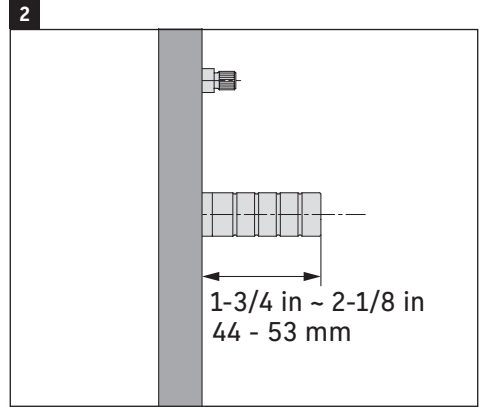
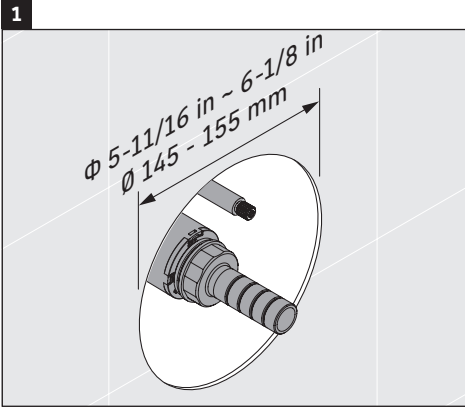

ATTENTION

> La plage d'ouverture dans la paroi doit se situer entre $\Phi 145 \text{ mm} \sim 155 \text{ mm}$ ($\Phi 5-11/16 \text{ po} \sim 6-1/8 \text{ po}$).

> La distance entre le mur fini et la tige filetée doit se situer entre 44 et 53 mm ($1-3/4 \text{ po} \sim 2-1/8 \text{ po}$). Si elle est supérieure à 53 mm ($2-1/8 \text{ po}$), vous devrez couper la tige filetée.

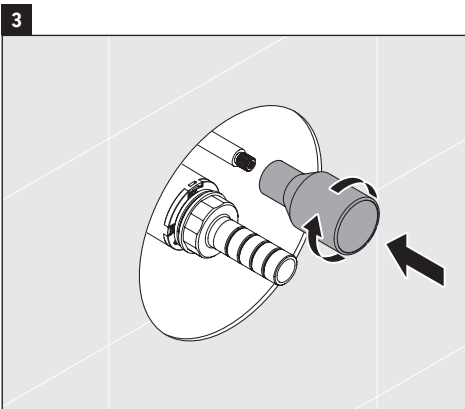

> Montez le manchon dans la vanne en le tournant dans le sens des aiguilles d'une montre.

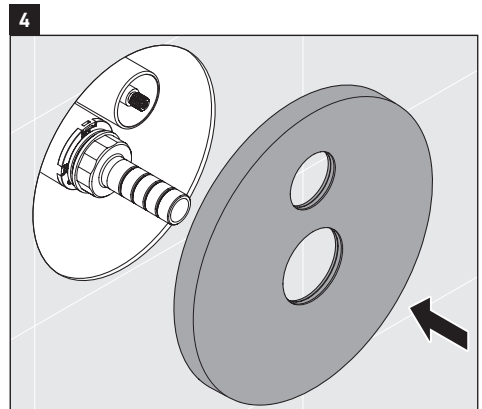

> Montez la plaque de garniture.

fr



5

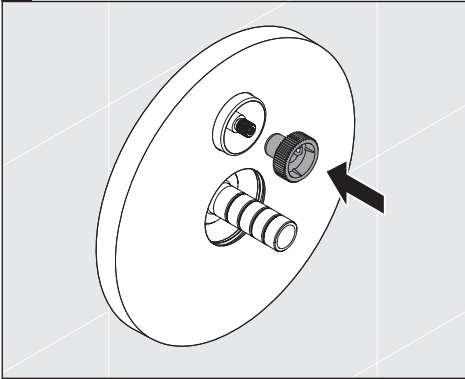

> Montez l'adaptateur cannelé en l'insérant, dents contre dents.

6

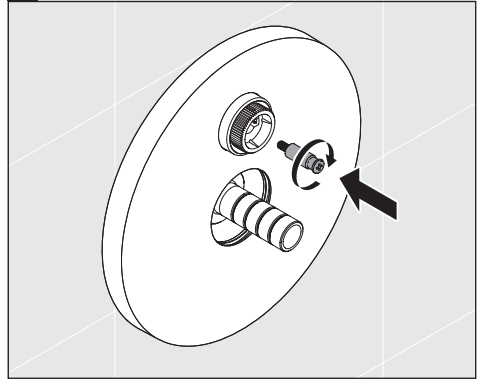

> Installez la vis sur la tige de la vanne en la tournant dans le sens des aiguilles d'une montre.

7

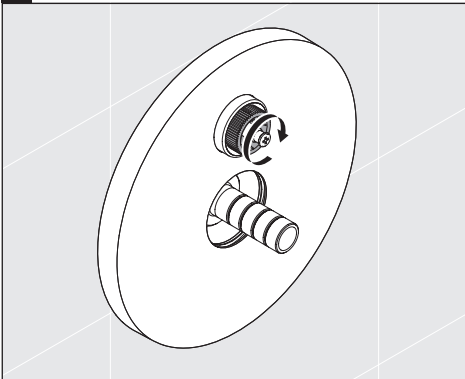

> Tournez l'adaptateur cannelé jusqu'à ce qu'il soit serré.

ATTENTION

> Ne le serrez pas trop.

8

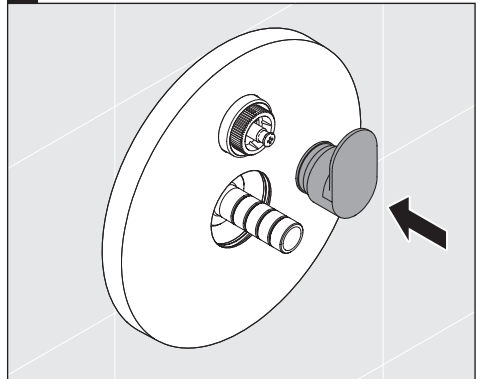

> Placez la poignée vers le haut, puis installez le jeu de poignées sur l'adaptateur cannelé, dents contre dents.



9

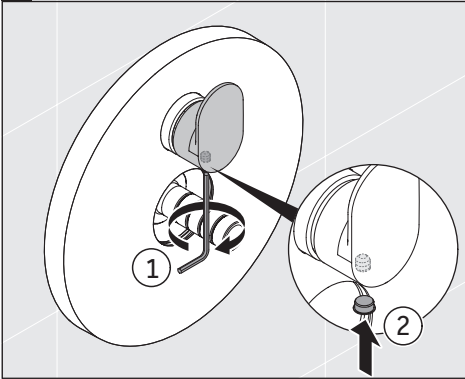

- > Utilisez une clé Allen pour tourner la vis sur le côté de la poignée de l'inverseur. Ne la serrez pas trop.
- > Placez le bouchon sur la poignée de l'inverseur.

10

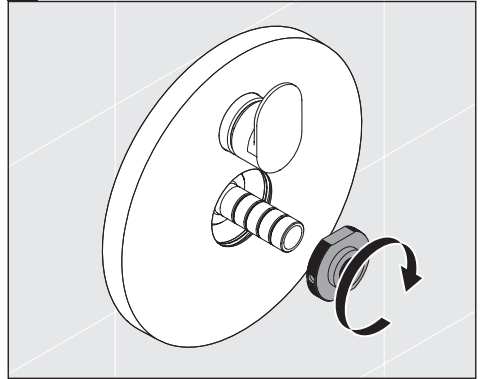

- > Placez le joint sur la tige de la vanne et tournez-le dans le sens des aiguilles d'une montre. Serrez-le jusqu'en butée.

11

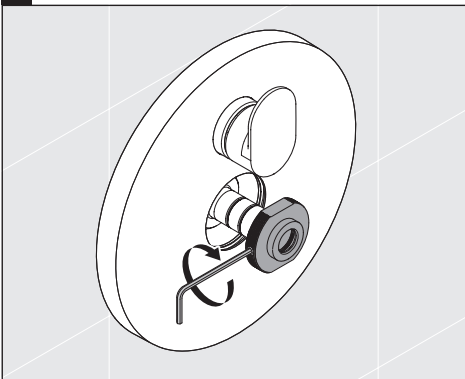

- > Serrez la vis de réglage à l'aide d'une clé Allen.

MISE EN GARDE

- > Ne faussez pas le filetage.

12

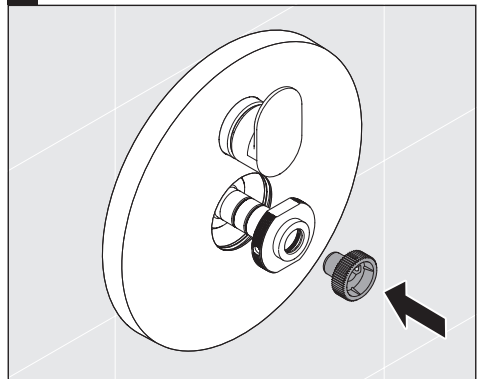

- > Installez l'adaptateur cannelé dents contre dents.

fr



13

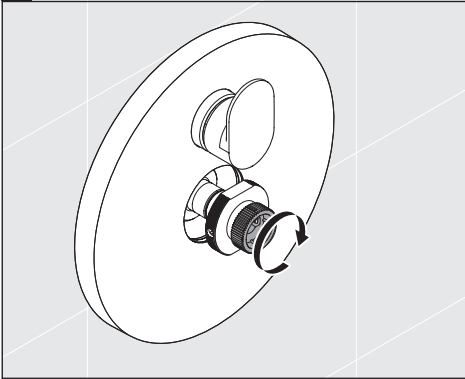

- > Tournez l'adaptateur cannelé dans le sens des aiguilles d'une montre jusqu'à ce qu'il soit serré.

ATTENTION

- > Ne le serrez pas trop.

14

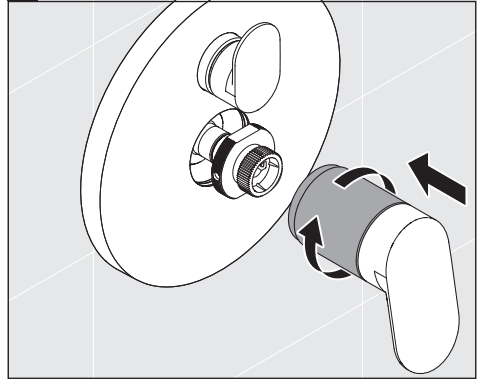

- > **Placez la poignée en position basse** et installez le jeu de poignées sur l'adaptateur cannelé, dents contre dents.
- > Tournez le manchon de la poignée dans le sens des aiguilles d'une montre jusqu'à ce qu'il soit fermement appuyé contre la garniture.

MISE EN GARDE

- > Ne le serrez pas trop. Si la poignée semble trop serrée, desserrez légèrement le manchon.

15

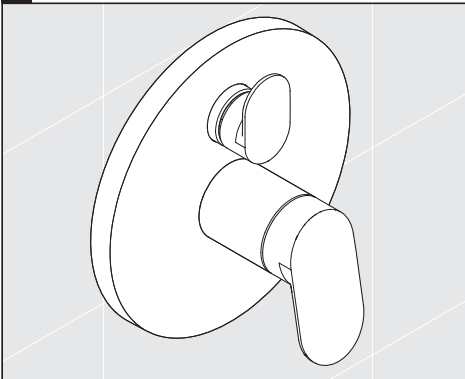

- > Installation terminée.

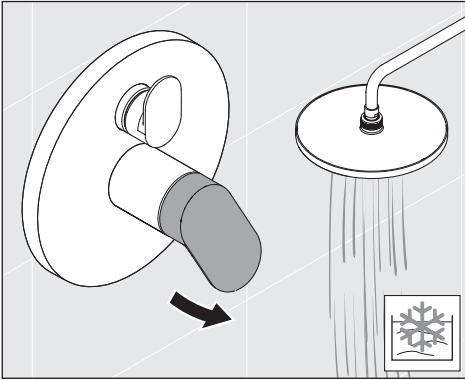

- > Déplacez la poignée dans le sens inverse des aiguilles d'une montre pour mettre la douche en marche.

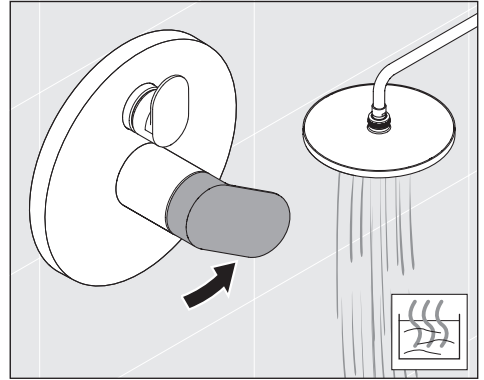

- > Déplacez la poignée dans le sens inverse des aiguilles d'une montre pour passer du froid au chaud.

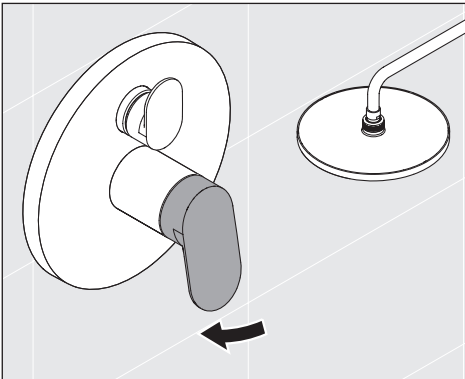

- > Arrêtez la douche en déplaçant la poignée dans le sens des aiguilles d'une montre jusqu'à la position de départ.

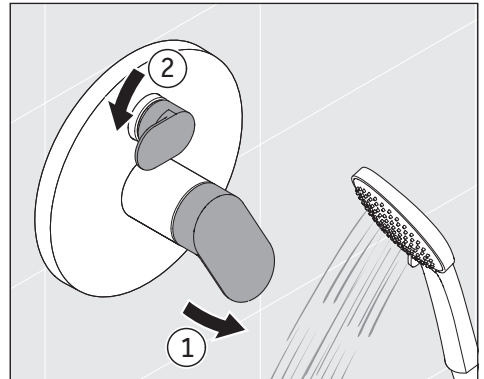

- > Pour inverser la fonction de douche à douchette ou bec déverseur, tournez la poignée de l'inverseur dans le sens inverse des aiguilles d'une montre.

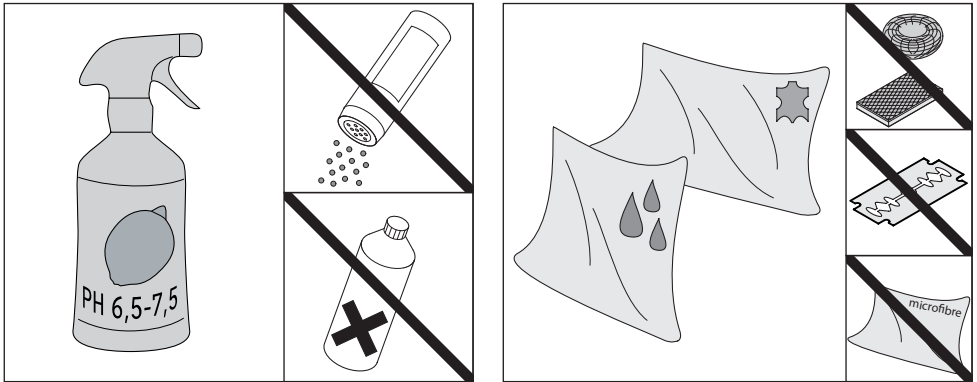

Produits chimiques/nettoyants à éviter :

- Des produits abrasifs et polissant, dont des nettoyants à base de javellisant
- Scrubbing bubbles et Lysol pour la baignoire
- Soft scrub, nettoyant pour carrelage et Windex original
- Fantastik antibactérien puissant et Comet nettoyant pour la salle de bain
- Des produits contenant des acides fluorhydriques
- Des acides chlorhydriques et/ou phosphoriques
- Tout produit contenant des agents corrosifs
- Tout produit contenant de l'ammoniaque, de l'eau de javel ou de l'acide

Produits chimiques/nettoyants recommandés :

Nettoyant doux (ph 7) à base d'acide citrique

Outils de nettoyage à éviter :

- Tampons nettoyants abrasifs
- Grattoirs
- Outils de nettoyage abrasifs

Outils de nettoyage recommandés :

- Linge doux humide
- Cuirette



1

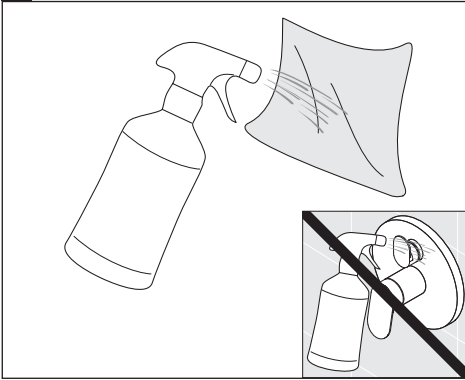

ATTENTION

La fine brume peut s'infiltrer et endommager les robinets et les raccords

- > Vaporisez du produit nettoyant sur un chiffon de nettoyage, non pas directement sur le produit.

2

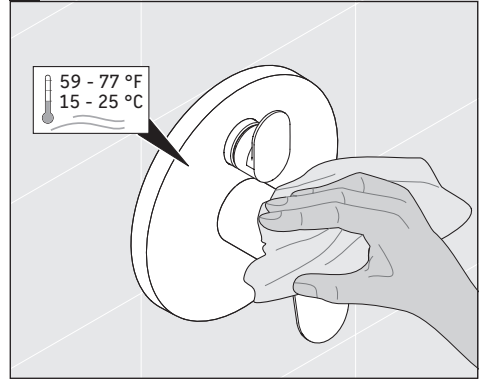

- > Pour préserver la finition, la température doit pas dépasser 25 °C (77 °F).

3

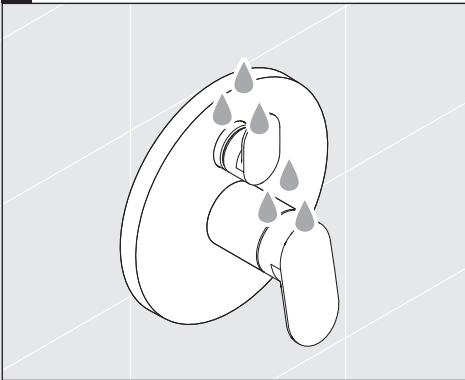

- > Rincez à l'eau.

4

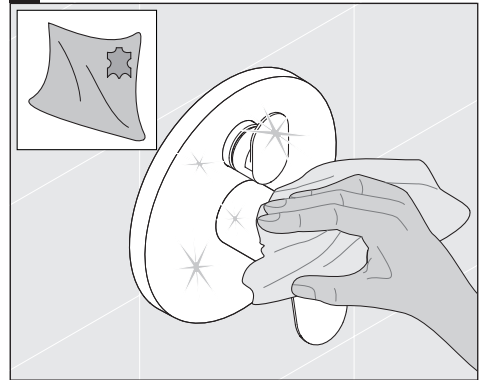

- > Séchez avec un chiffon propre.

fr



Estas instrucciones de montaje forman parte del producto Duravit y es necesario leerlas detenidamente antes del montaje.

Lectores destinatarios y cualificaciones

La instalación del producto solo puede llevarse a cabo por un fontanero cualificado.



Esta unidad cumple o excede las siguientes normas:

- ASME A112.18.1
- CSA B125.1
- En cumplimiento con ADA

Instrucciones de seguridad

Lesiones por corte y aplastamiento

- > Llevar guantes durante la instalación del producto.

Daños materiales y/o en el producto

- > Observar en todo momento los reglamentos locales de instalación y las normas específicas de cada país.
- > Igualar las diferencias de presión de las conexiones de agua fría y caliente.
- > Observar las instrucciones del fabricante para la instalación de sistemas de calefacción de flujo continuo.

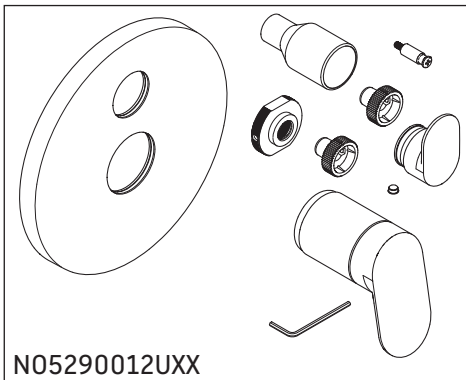
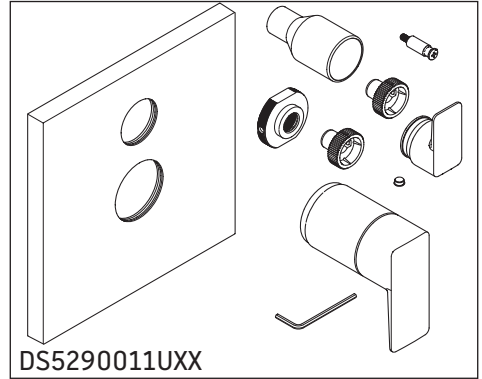
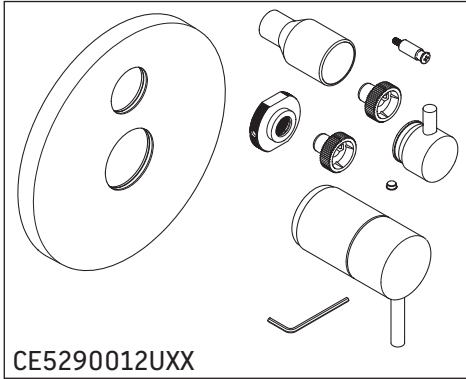

NOTA:

La válvula de ajuste de presión GK0900011U00 se debe instalar antes que el embellecedor.

Las ilustraciones pueden diferir del producto real.

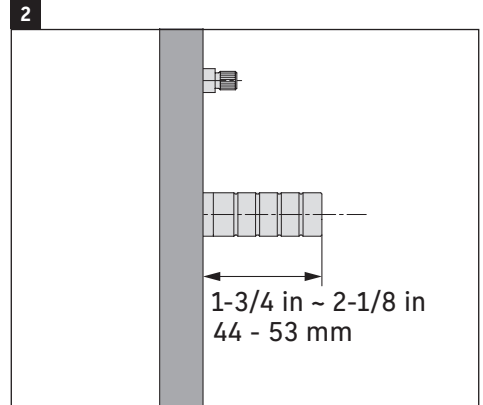
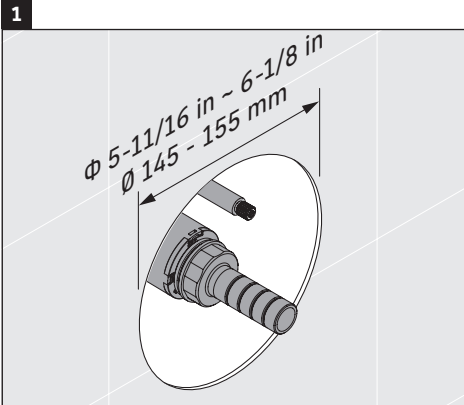

AVISO

> El rango de apertura del muro deberá situarse entre Φ 5-11/16 in ~ 6-1/8 in (Φ 145 mm - 155 mm).

> La distancia entre el muro acabado y la varilla roscada debe situarse entre 1-3/4 in - 2-1/8 in (44 - 53 mm). Si es superior a 2-1/8 in, deberá cortar la varilla roscada.

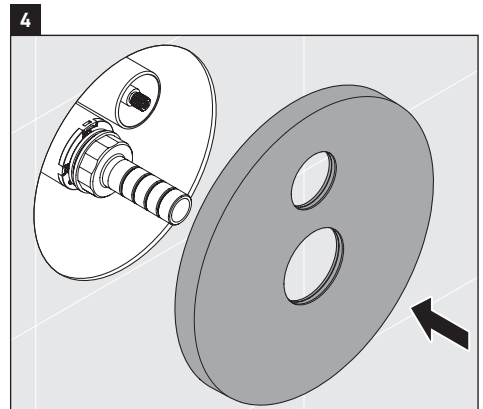
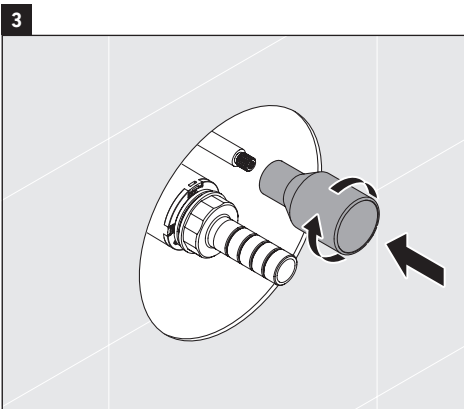

> Montar el manguito girando en sentido horario en la válvula.

> Montar la placa del embellecedor.



5

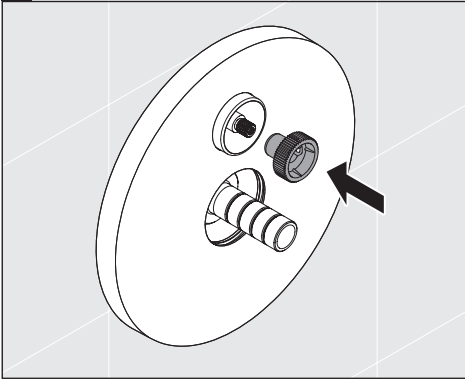

> Montar el adaptador ranurado juntándolo diente con diente.

6

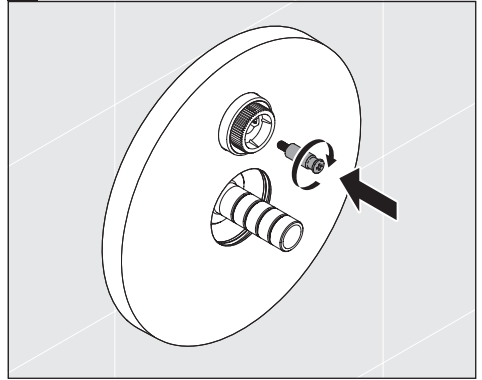

> Instalar el tornillo girando en el sentido horario en la varilla de la válvula.

7

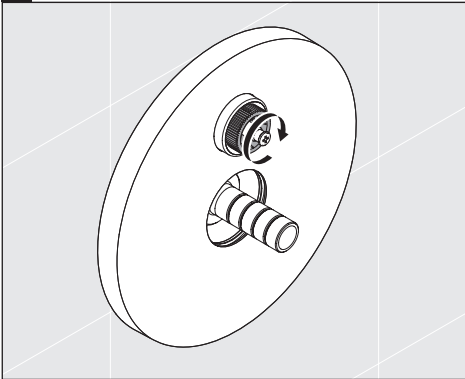

> Girar el adaptador ranurado hasta que esté apretado.

AVISO

> No apretar demasiado.

8

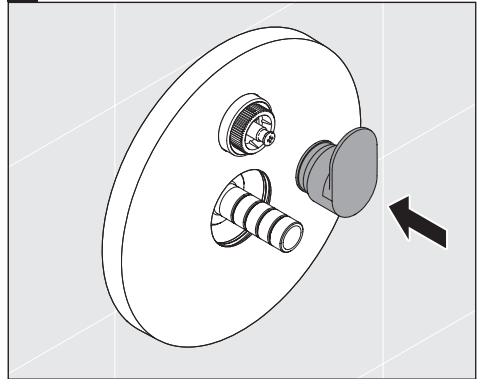

> Poner el mando en posición hacia abajo e instalar el juego del mando en el adaptador ranurado diente con diente.



9

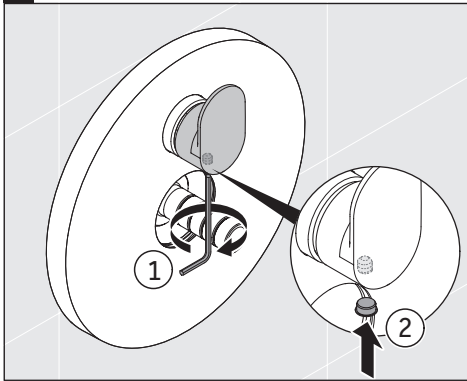

- > Utilizar una llave Allen para gira el tornillo del lateral del monomando. No apretar demasiado.
- > Colocar el tapón en el monomando.

10

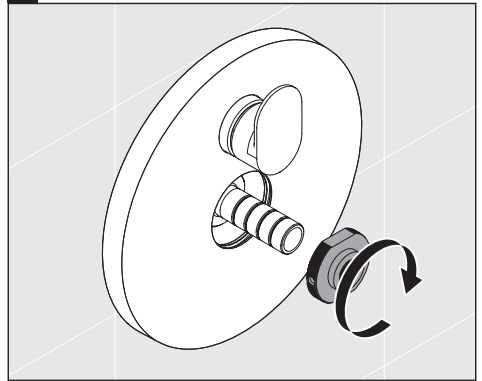

- > Colocar la junta en la varilla roscada de la válvula y girar en el sentido horario. Apretar hasta que se detenga.

11

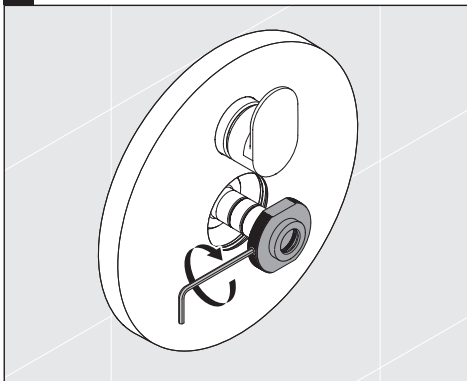

- > **Apretar el tornillo de fijación con la llave Allen.**

ATENCIÓN

- > No descentrar la rosca.

12

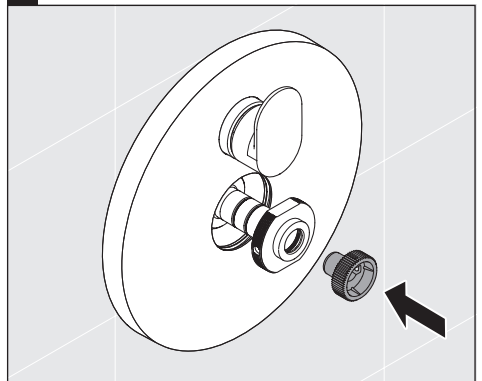

- > Instalar el adaptador ranurado diente con diente.



13

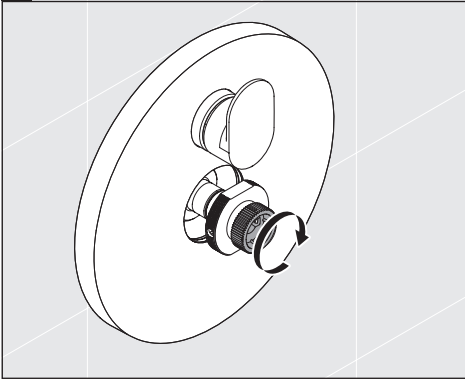

- > Girar el adaptador ranurado en el sentido horario hasta que esté apretado.

AVISO

- > No apretar demasiado.

14

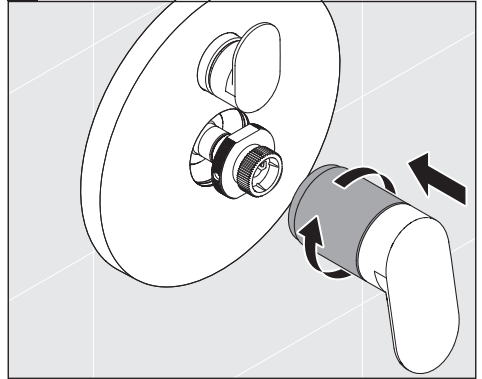

- > **Poner el mando en posición hacia abajo e** instalar el juego del mando en el adaptador ranurado diente con diente.
- > Girar el manguito del mando en el sentido horario hasta que quede apretado contra el embellecedor.

ATENCIÓN

- > No apretar demasiado. Si el mando parece que está demasiado apretado, soltar ligeramente el manguito del mando.

15

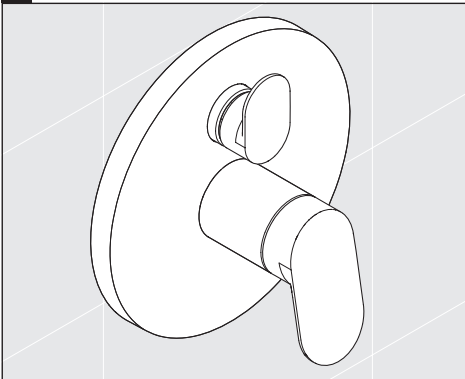

- > Se ha completado la instalación.

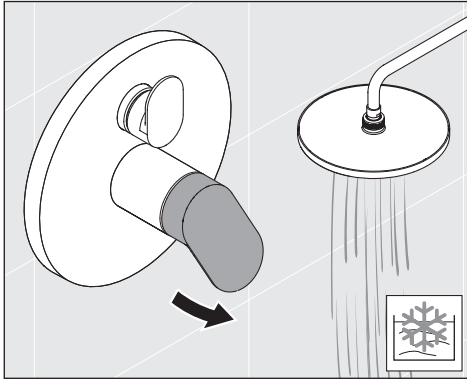

> Mover el mando en sentido horario para abrir la ducha.

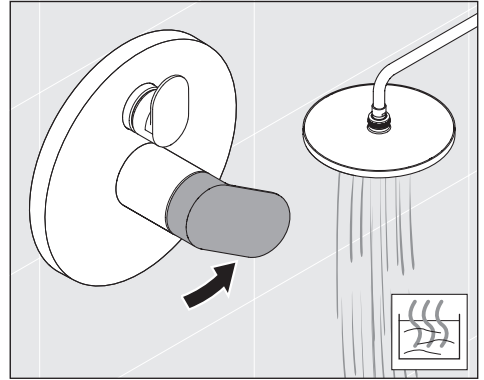

> Mover el mando en sentido antihorario para pasar de frío a caliente.

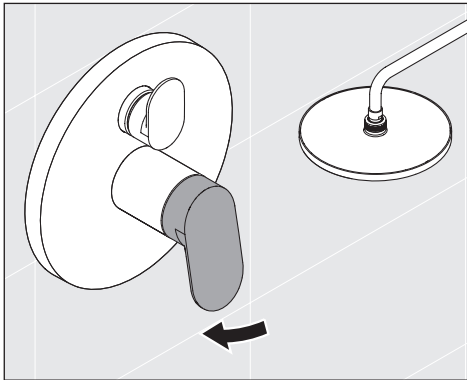

> Cerrar la ducha moviendo el mando en el sentido horario hacia la posición inicial.

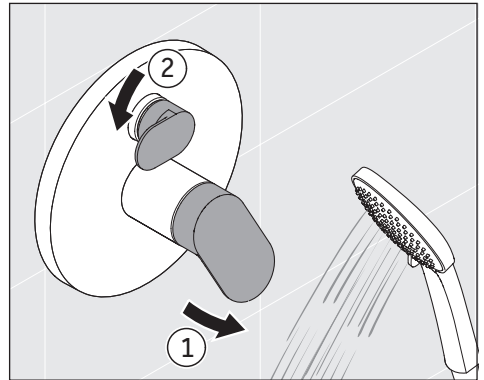

> Para cambiar la función de ducha a ducha de mano o a caño de la bañera, girar el monomando en el sentido antihorario.

**Productos químicos/limpiadores que se deben evitar:**

- Productos abrasivos y abrillantadores, incluidos los productos de limpieza con base de lejía
- Burbujas de limpieza y Lysol para lavabos
- Limpiador de superficies, producto para limpiar azulejos y Windex original
- Fantástico producto de limpieza para baños Comet, antibacteriano y altamente resistente
- Productos que contienen ácido fluorhídrico
- Ácidos clorhídricos y/o fosfóricos
- Cualquier producto con agentes cáusticos
- Cualquier producto con amoníaco, lejía o ácidos

Productos químicos/limpiadores recomendados:

Producto de limpieza suave (pH 7) con base de ácido cítrico.

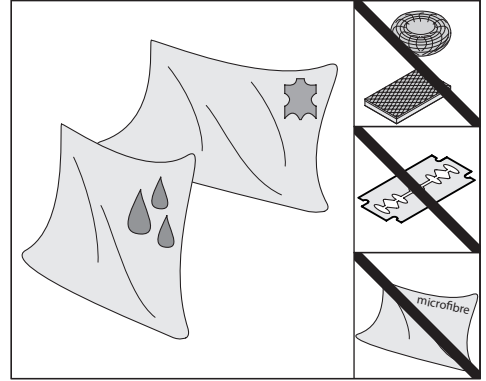
**Herramientas de limpieza que se deben evitar:**

- Esponjas limpiadoras abrasivas
- Raspadoras
- Herramientas de limpieza abrasivas

Herramientas de limpieza recomendadas:

- Paño suave humedecido
- Gamuza de piel natural

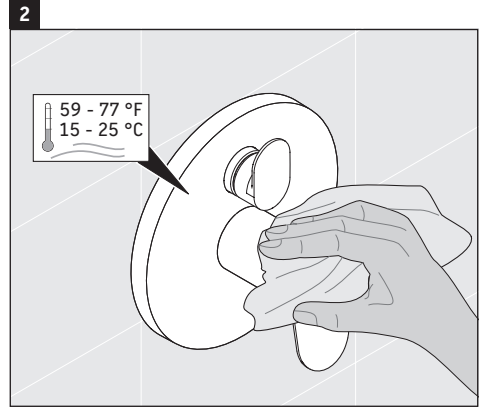
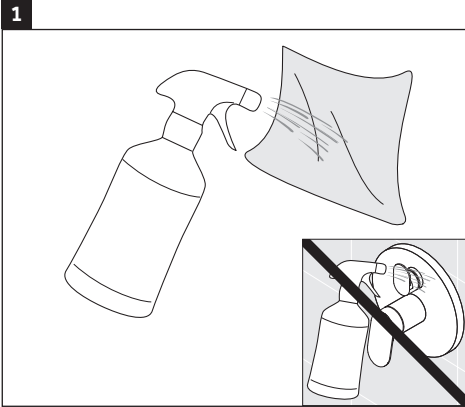

AVISO

La neblina de spray puede penetrarse en la grifería y los accesorios y dañarlos

> Para proteger el acabado, la temperatura no debe exceder los 25 °C (77 °F).

> Pulverizar el aerosol de limpieza sobre un paño de limpieza y no directamente sobre el producto.

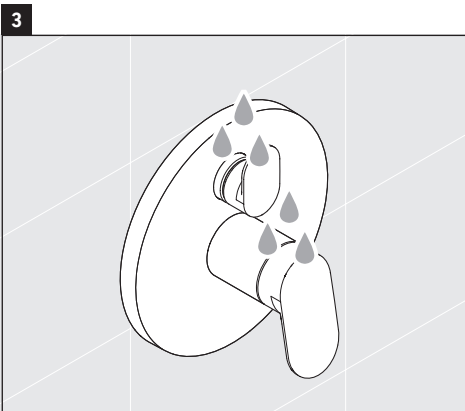

> Aclarar con agua.

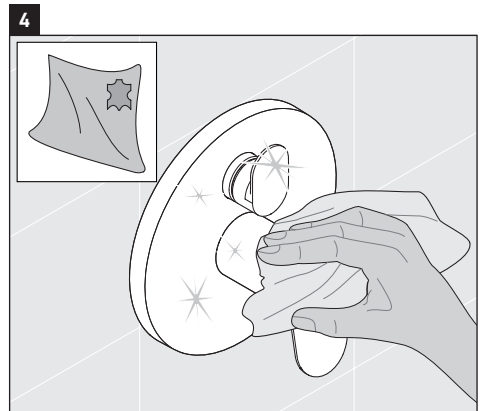

> Secar con un paño limpio.

DURAVIT USA, INC.
2635 North Berkeley Lake Rd., Ste. 100
Duluth, GA 30096
Toll Free 888-DURAVIT
Phone 770-931-3575
Fax 770-931-8454
info@us.duravit.com
www.duravit.us

