

148 P2 1/2"-2"

ULTRAPRESS®

Bronze Gate Valve
200 psig @ 250°F †
Solid Wedge Disc • Rising Stem
Threaded Bonnet • Press Ends
Conforms to: MSS SP-80

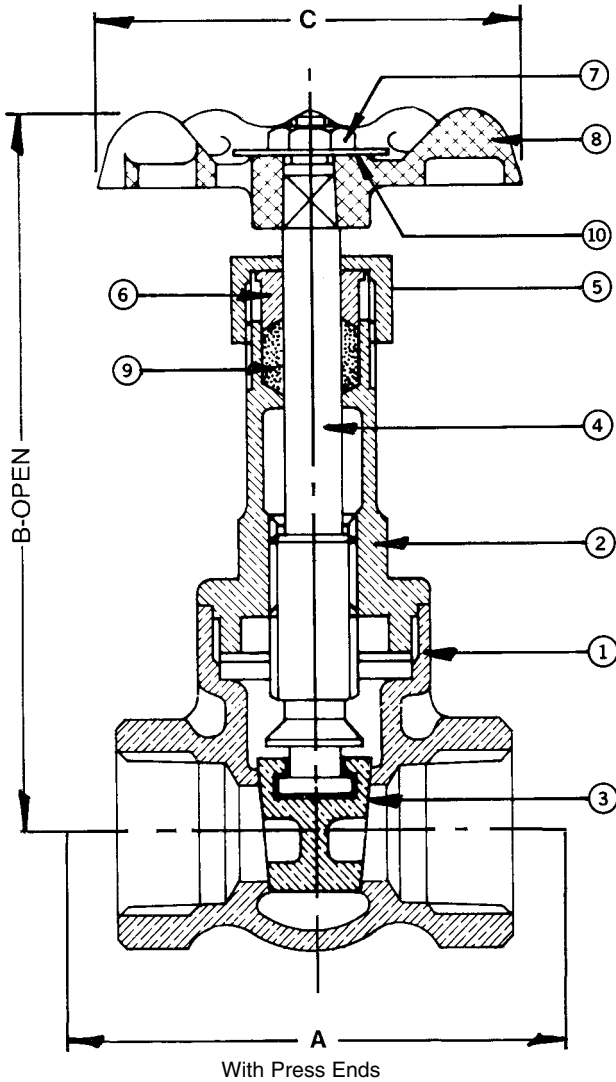

Note: Not intended for use in potable water.

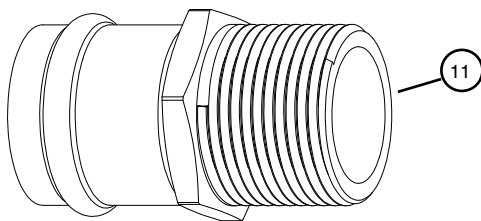

Press End Adapter (4151 Series)

MATERIAL LIST			
No.	PART	MATERIAL	SPECIFICATION
1	Body	Bronze	ASTM B62
2	Bonnet	Bronze	ASTM B62
3	Wedge	Bronze	ASTM B62
4	Stem	Bronze	ASTM B62
5	Packing Nut	Brass	ASTM B283 C37700
6 ¹	Gland	Brass	ASTM B124 C37700
7	Handwheel Nut	Brass	Commercial
8	Handwheel	Mall. Iron	Commercial
9	Packing	Graphite	Commercial
10	Name Plate	Sh. Alum	Commercial
11	Press Adapter	Brass Fitting W/ EPDM O-Ring	ASTM C27450

¹ Not used on 1/2"

DIMENSIONS - INCHES/MILLIMETERS						
Units	Size	STD Insertion Depth	A	B	C	C _v
Inches mm	1/2	0.87 22	5.00 127	4.38 111	2.00 51	17.6
Inches mm	3/4	0.98 25	5.76 146	5.84 148	2.50 64	32.0
Inches mm	1	0.98 25	6.56 167	7.06 179	2.75 70	54.0
Inches mm	1 1/4	1.02 26	6.85 174	8.78 223	3.44 87	97.0
Inches mm	1 1/2	1.42 36	7.29 185	9.50 241	3.75 95	135.0
Inches mm	2	1.58 40	9.31 236	11.50 292	3.75 95	230.0

† Non-Shock

INNOVATION IN EVERY VALVE

The information presented on this sheet is correct at time of publication. Milwaukee Valve reserves the right to change design and/or materials without notice. For our Installation, Operation and Maintenance Manual and the most current product information go to www.milwaukeevalve.com. State of California Prop 65 **WARNING: Cancer and Reproductive Harm.** For more information visit www.p65warnings.ca.gov.

MILWAUKEE VALVE