

1510T 1/2"-2"

Bronze Check Valve
150 SWP - 300 WOG †
Horizontal Swing • Solder Ends
TFE Disc
Conforms to: MSS SP-80

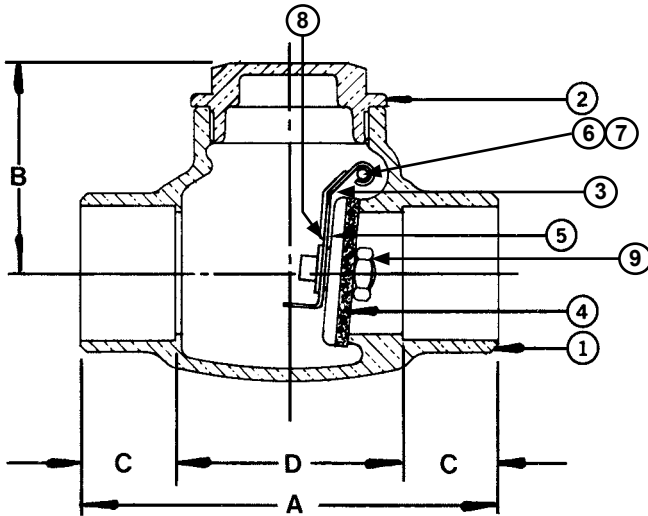

Note: Not intended for use in potable water.

MATERIAL LIST			
No.	PART	MATERIAL	SPECIFICATION
1	Body	Bronze	ASTM B62
2	Cap	Bronze	ASTM B62
3	Lever	Brass	Commercial
4	Disc	Teflon	
5	Disc Holder	Brass	ASTM B16 1/2" to 3/4"
		Bronze	ASTM B62 1" to 2"
6	Pin	St. Steel	Commercial
7	Plug (not shown)	Brass	ASTM B16
8	Retaining Ring	St. Steel	Commercial
9	Disc Nut	Brass	ASTM B16

DIMENSIONS - INCHES/MILLIMETERS						
Units	Size	A	B	C	D	C _v
Inches mm	1/2	2.75 70	1.32 34	0.50 13	1.75 44	10.0
Inches mm	3/4	3.31 84	1.69 43	0.75 19	1.81 46	18.0
Inches mm	1	4.00 102	1.97 50	0.91 23	2.18 55	31.0
Inches mm	1 1/4	4.25 108	2.16 55	0.97 25	2.31 59	54.0
Inches mm	1 1/2	4.94 125	2.41 61	1.09 28	2.76 70	76.0
Inches mm	2	6.13 156	2.81 71	1.34 34	3.45 88	131.0

† Non-Shock

INNOVATION IN EVERY VALVE



MILWAUKEE VALVE

The information presented on this sheet is correct at time of publication. Milwaukee Valve reserves the right to change design and/or materials without notice. For our Installation, Operation and Maintenance Manual and the most current product information go to www.milwaukeevalve.com. State of California Prop 65 **WARNING:** Cancer and Reproductive Harm. For more information visit www.p65warnings.ca.gov.