

Milwaukee Valve Cast Steel Gate, Globe, and Check Valves

API 600 GATE VALVES

- Flexible split wedge for improved seating
- 2-bolt adjustable stem packing arrangement for longer packing life
- Grounded finish on stem for improved packing seal
- Outside Screw & Yoke rising stem design
- Seal-welded seat rings for stable shut-off
- Handwheel, bevel gear operator, or electric actuation available
- Size range 2" - 24" (CL 150/300), 2" - 12" (CL 600). Contact factory for additional sizes.



API 623 GLOBE VALVES

- Rotating seat disc for improved seating
- Outside Screw & Yoke rising stem design
- Integral seat with body and disc overlay
- 2-bolt adjustable stem packing arrangement for longer packing life
- Size range 2" - 8" (CL 150/300), 2" - 6" (CL 600). Contact factory for additional sizes.

API 594 SWING CHECK VALVES

- Horizontal full port design with bolted cover
- Pinned rotating disc for improved sealing
- Seal-welded seat rings for stable shut-off
- Size range 2" - 12" (CL 150/300/600). Contact factory for additional sizes.

SPECIFICATIONS & STANDARDS

Design	API (as noted), ASME B16.34
Flange Connections	ASME B16.5
Butt-Weld Connections	ASME B16.25
End-to-End Dimensions	ASME B16.10
Testing and Inspection	API 598
Pressure & Temperature	ASME B16.34
By-Passes & Drains	MSS SP-45
Materials	ASTM standards

Notes:

1. Heat codes and MTR's provided for traceability of each valve.
2. Contact factory for optional trim materials or larger sizes.
3. Customer must specify pipe schedule for butt-weld ends.
4. Operating temperature range is -20 to 800°F per ASME B16.34.

HOW TO ORDER MILWAUKEE VALVE CAST STEEL

15 5 0 CB 2 HW M BP

Pressure Class:
15 = Class 150
30 = Class 300
60 = Class 600

Type:
5 = Gate
6 = Globe
7 = Check

Pipe Ends:
0 = Flanged
2 = Butt-Weld (Std)
3 = Butt-Weld (Extra Heavy)

Body Material:
CB = A216 WCB

Trim Material:
2 = API 8 (std)
(Contact factory for all other trim options)

Operator:
HW = Handwheel
GB = Bevel Gear Operator
SC = Swing Check (No Operator)
(Contact factory for Actuation)

Options:
(blank) = None
BP = By-Pass
DT = Drilled & Tapped

Revision:
M = Designated Manufacturer

The information presented on this sheet is correct at time of publication. Milwaukee/Hammond Valve reserves the right to change design and/or materials without notice. For our Installation, Operation and Maintenance Manual and the most current product information go to www.milwaukeevalve.com or www.hammondvalve.com. ⚠ State of California Prop 65 **WARNING:** Cancer and Reproductive Harm. For more information visit www.p65warnings.ca.gov.



3050CB2M FLANGED ENDS 3052CB2M BUTT-WELD ENDS GATE CLASS 300 2"-8"

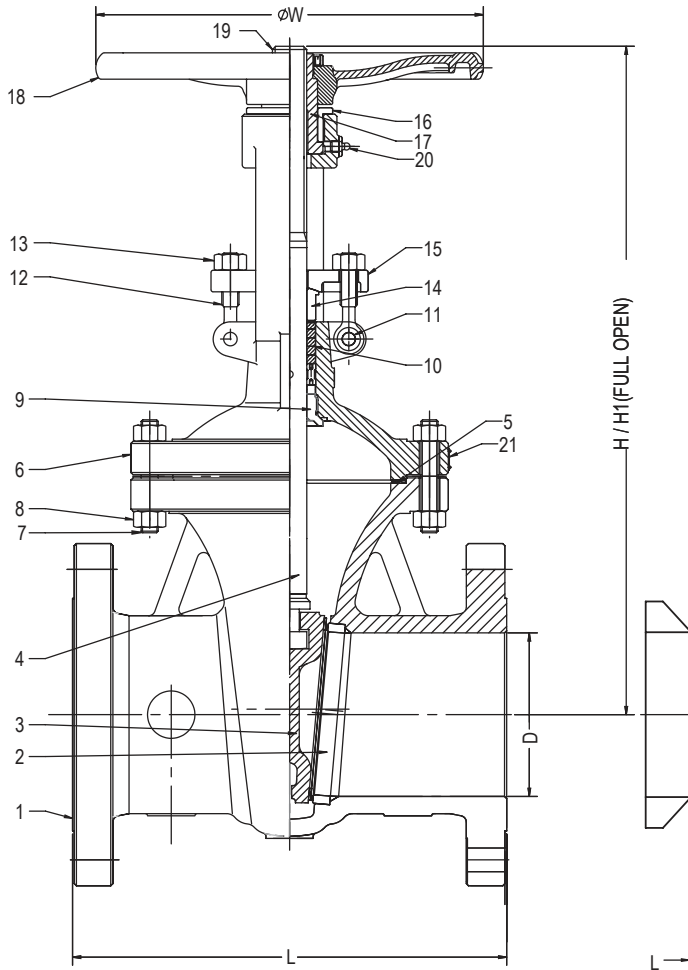

SPECIFICATIONS		
DESIGN: API 600 12th Edition, ASME B16.34		
PRESSURE-TEMP RATINGS: ASME B16.34		
CONNECTIONS: ASME B16.5, B16.25		
FACE TO FACE: ASME B16.10		
TEST & INSPECTION: API 598 RP 591		
MATERIALS: ASTM		
MATERIAL LIST		
ITEM	PART NAME	MATERIAL
1	BODY	A216 WCB
2	SEAT RING	A105+STL6
3	WEDGE	A216 WCB+13Cr
4	STEM	A182 F6a
5	GASKET	GRAPHITE+SS CORE
6	BONNET	A216 WCB
7	STUD BODY/BONNET	A193 B7
8	NUT BODY/BONNET	A194 2H
9	BACKSEAT BUSHING	A276 410
10	PACKING	GRAPHITE
11	GLAND EYEBOLT PIN	A29 2H
12	GLAND EYEBOLT	A193 B7
13	GLAND EYEBOLT NUT	A194 2H
14	GLAND	A276 410
15	GLAND FLANGE	A216 WCB
16	YOKE BUSHING	A216 WCB
17	YOKE BUSHING NUT	A439 D2
18	HANDWHEEL	A536
19	HANDWHEEL NUT	A29 1035D
20	GREASE FITTING	A36
21	NAMEPLATE	A240 321

SIZE		L FACE TO FACE	D DIA	H CLOSED	H1 FULL OPEN	W HANDWHEEL	C _v
2"	IN	8.50	2.01	15.47	17.91	7.87	310
	MM	216	51	393	455	200	
2.5"	IN	9.49	2.52	16.46	19.41	9.84	480
	MM	241	64	418	493	250	
3"	IN	11.14	2.99	18.31	21.73	9.84	710
	MM	283	76	465	552	250	
4"	IN	12.01	4.02	21.02	25.55	11.81	1300
	MM	305	102	534	649	300	
5"	IN	15.00	5.00	23.78	29.33	13.78	1950
	MM	381	127	604	745	350	
6"	IN	15.87	5.98	26.42	32.99	13.78	3100
	MM	403	152	671	838	350	
8"	IN	16.50	7.99	32.05	40.67	17.72	5720
	MM	419	203	814	1033	450	

The information presented on this sheet is correct at time of publication. Milwaukee/Hammond Valve reserves the right to change design and/or materials without notice. For our Installation, Operation and Maintenance Manual and the most current product information go to www.milwaukeevalve.com or www.hammondvalve.com. ⚠ State of California Prop 65 **WARNING:** Cancer and Reproductive Harm. For more information visit www.p65warnings.ca.gov.

