

504 1/4" - 2 1/2"

Bronze Angle Valve
125 SWP - 200 WOG †
Bronze Disc
Threaded Bonnet • Threaded Ends
Conforms to: MSS SP-80

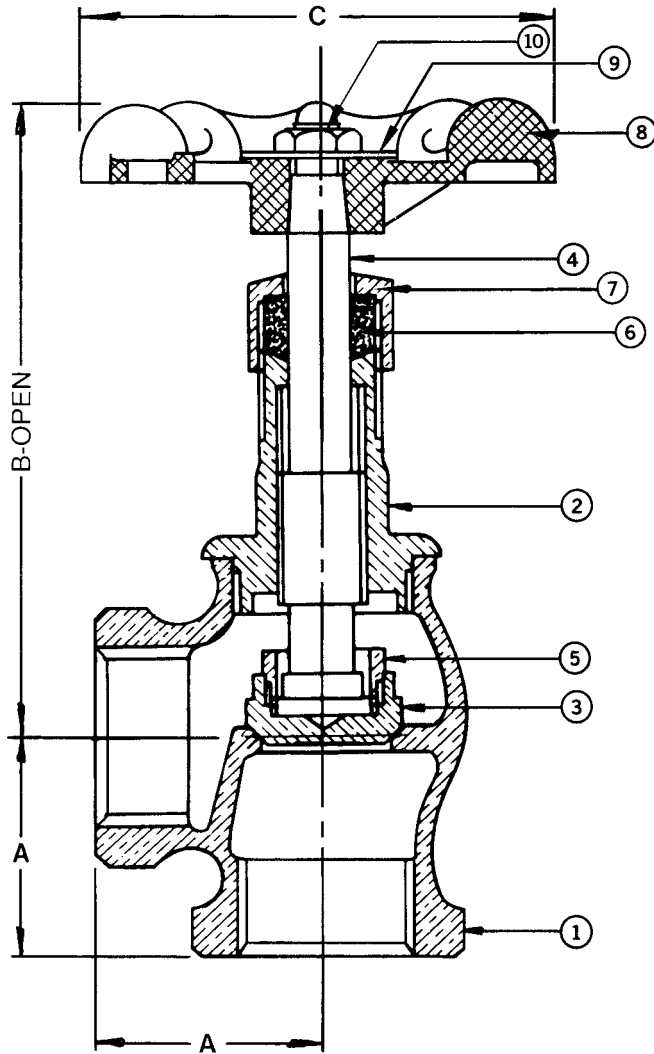

Note: Not intended for use in potable water.

MATERIAL LIST			
No.	PART	MATERIAL	SPECIFICATION
1	Body	Bronze	ASTM B62
2	Bonnet	Bronze	ASTM B62
3	Disc	Bronze	ASTM B62
4	Stem	Bronze	ASTM B62
5	Disc Ring	Brass	ASTM B 16 3/4" to 2" ASTM B 62 2 1/2"
6	Packing	Graphite	Commercial
7	Packing Nut	Brass	ASTM B16
8	Handwheel	Mall. Iron	Commercial
9	Name Plate	Aluminum	Commercial
10	Handwheel Nut	Brass	Commercial
11	Gland (not shown)	Bronze	ASTM B 16

• 1/4" to 1/2" sizes have the disc integral with the stem and have no disc ring.

DIMENSIONS - INCHES/MILLIMETERS					
Units	Size	A	B	C	C _v
Inches mm	1/4	0.75 19	3.06 78	2.00 51	1.60
Inches mm	3/8	0.91 23	3.19 81	2.00 51	3.10
Inches mm	1/2	1.00 25	3.63 92	2.25 57	5.10
Inches mm	3/4	1.25 32	3.94 100	2.00 51	9.20
Inches mm	1	1.44 37	4.38 111	2.75 70	16.00
Inches mm	1 1/4	1.69 43	5.19 132	3.44 87	28.00
Inches mm	1 1/2	1.81 46	5.75 146	3.75 95	39.00
Inches mm	2	2.19 56	6.75 172	4.25 108	66.00
Inches mm	2 1/2	3.00 76	8.63 219	4.75 121	100.00

† Non-Shock

INNOVATION IN EVERY VALVE

The information presented on this sheet is correct at time of publication. Milwaukee Valve reserves the right to change design and/or materials without notice. For our Installation, Operation and Maintenance Manual and the most current product information go to www.milwaukeevalve.com.  State of California Prop 65
WARNING: Cancer and Reproductive Harm. For more information visit www.p65warnings.ca.gov.

MILWAUKEE VALVE