

# 509/509T P2 1/2"-2"

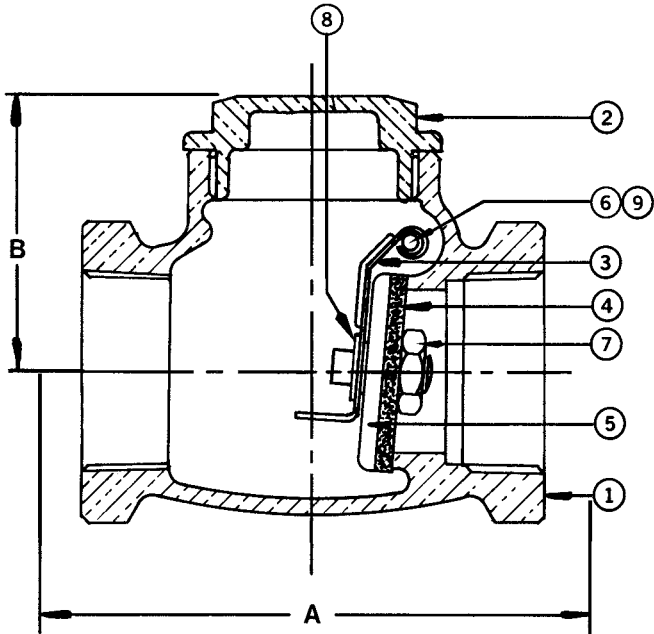

**Bronze Check Valve**  
**200 psig @ 250°F †**  
**Horizontal Swing • Press Ends**  
**Conforms to: MSS SP-80**



With Press Ends

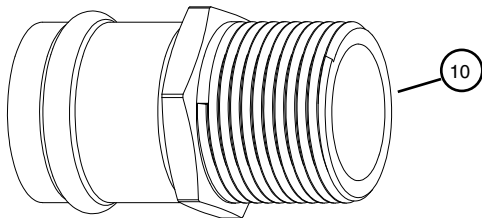

Press End Adapter (4151 Series)

Note: Not intended for use in potable water.

MATERIAL LIST			
No.	PART	MATERIAL	SPECIFICATION
1	Body	Bronze	ASTM B62
2	Cap	Bronze	ASTM B62
3	Lever	Stainless Steel 509 P2	Commercial 1/2" to 2"
		Brass 509T P2	ASTM B 16 1/2" to 2"
4	Disc	Brass 509 P2	ASTM B 16 1/2" to 3/4"
			ASTM B 453 1" to 1 1/2"
		Brone 509 P2	ASTM B62 2"
		PTFE 509T P2	Commercial
5	Disc Holder (509T P2 Only)	Brass	ASTM B16 1/2" to 3/4"
		Bronze	ASTM B62 1" to 2"
6	Pin	St. Steel	Commercial
7	Disc Nut	Brass	ASTM B16
8	Retaining Ring	St. Steel	Commercial
9	Plug (not shown)	Brass	ASTM B16
10	Press Adapters	Brass Fitting w/EPDM O-ring	ASTM B283 C27450

DIMENSIONS - INCHES/MILLIMETERS					
Units	Size	STD Insertion Depth	A	B	C <sub>v</sub>
Inches mm	1/2	0.87 22	5.31 135	1.32 34	10.0
Inches mm	3/4	0.98 25	6.21 158	1.69 43	18.0
Inches mm	1	0.98 25	7.25 184	2.00 51	31.0
Inches mm	1 1/4	1.02 26	7.63 194	2.13 54	54.00
Inches mm	1 1/2	1.42 36	8.48 215	2.38 60	76.00
Inches mm	2	1.58 40	10.75 273	2.81 71	131.00

† Non-Shock



The information presented on this sheet is correct at time of publication. Milwaukee Valve reserves the right to change design and/or materials without notice. For our Installation, Operation and Maintenance Manual and the most current product information go to [www.milwaukeevalve.com](http://www.milwaukeevalve.com). State of California Prop 65  
**WARNING:** Cancer and Reproductive Harm. For more information visit [www.p65warnings.ca.gov](http://www.p65warnings.ca.gov).

