

# 582 1/4"-2"

**Bronze Angle Valve**  
**300 SWP - 600 WOG †**  
**Bronze Renewable Disc**  
**Union Bonnet • Threaded Ends**  
**Conforms to: MSS SP-80**

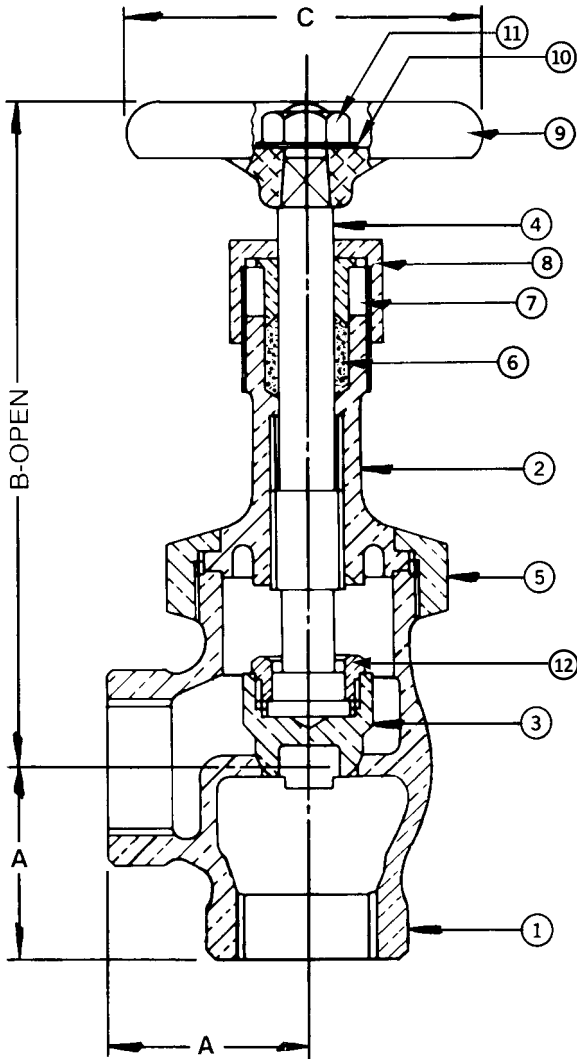

Note: Not intended for use in potable water.

MATERIAL LIST			
No.	PART	MATERIAL	SPECIFICATION
1	Body	Bronze	ASTM B61
2	Bonnet	Bronze	ASTM B61
3	Disc	Bronze	ASTM B61
4	Stem	Bronze	ASTM B61
5	Union Bonnet Nut	Bronze	ASTM B61
6	Packing	Graphite	Commercial
7	Gland	Brass	ASTM B 124 C37700
8	Packing Nut	Brass	ASTM B16
9	Handwheel	Mall. Iron	Commercial
10	Name Plate	Aluminum	Commercial
11	Handwheel Nut	Brass	Commercial
12	Disc Ring	Brass	ASTM B16

DIMENSIONS - INCHES/MILLIMETERS					
Units	Size	A	B	C	C <sub>v</sub>
Inches	1/4	1.06	4.00	2.00	1.60
mm		27	102	51	
Inches	3/8	1.19	4.00	2.00	3.10
mm		30	102	51	
Inches	1/2	1.25	4.50	2.50	5.10
mm		32	114	64	
Inches	3/4	1.44	5.19	2.75	9.20
mm		37	132	70	
Inches	1	1.75	6.38	3.25	16.00
mm		45	162	83	
Inches	1 1/4	2.06	6.88	3.75	28.00
mm		52	175	95	
Inches	1 1/2	2.25	7.50	4.25	39.00
mm		57	193	108	
Inches	2	2.75	8.75	4.75	66.00
mm		70	222	121	

† Non-Shock

**INNOVATION** IN EVERY VALVE

The information presented on this sheet is correct at time of publication. Milwaukee Valve reserves the right to change design and/or materials without notice. For our Installation, Operation and Maintenance Manual and the most current product information go to [www.milwaukeevalve.com](http://www.milwaukeevalve.com). State of California Prop 65 **WARNING:** Cancer and Reproductive Harm. For more information visit [www.p65warnings.ca.gov](http://www.p65warnings.ca.gov).



**MILWAUKEE VALVE**