

591A 1/4"-2"

Bronze Globe Valve
150 SWP - 300 WOG †
Special Hardened S.S. Seat Ring and Disc
Union Bonnet • Threaded Ends
Conforms to: MSS SP-80

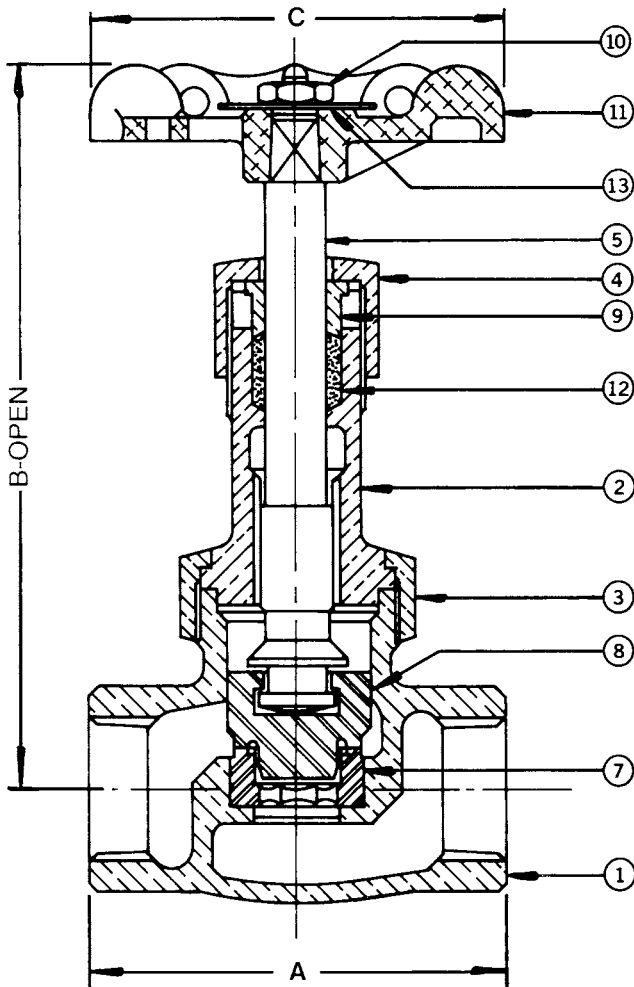

Note: Not intended for use in potable water.

MATERIAL LIST			
No.	PART	MATERIAL	SPECIFICATION
1	Body	Bronze	ASTM B62
2	Bonnet	Bronze	ASTM B62
3	Union Bonnet Nut	Bronze	ASTM B62
4	Packing Nut	Brass	ASTM B16
5	Stem	Bronze	ASTM B61
6 ¹	Disc Ring	Bronze	ASTM B62
7	Seat Ring	St. Steel	ASTM A 276, TY.420
8	Disc	St. Steel	ASTM A 276, TY.420
9	Gland	Brass	ASTM B 124 C37700
10	Handwheel Nut	Brass	ASTM B16
11	Handwheel	Mall. Iron	Commercial
12	Packing	Graphite	Graphite
13	Name Plate	Sh. Alum.	Commercial

¹ Not shown- used on 1 1/4" and larger valves only.

- This valve has flat seat shutoff with plug type disc for throttling action and replaceable seat and disc.

DIMENSIONS - INCHES/MILLIMETERS					
Units	Size	A	B	C	C _v
Inches	1/4	2.13	4.38	2.00	1.16
mm		54	111	51	
Inches	3/8	2.38	4.44	2.00	2.21
mm		60	113	51	
Inches	1/2	2.50	4.50	2.50	3.64
mm		64	114	64	
Inches	3/4	2.94	5.13	2.75	6.65
mm		75	130	70	
Inches	1	3.38	5.25	3.44	11.10
mm		86	133	87	
Inches	1 1/4	3.88	6.19	3.75	20.00
mm		98	157	95	
Inches	1 1/2	4.50	7.25	4.25	28.00
mm		114	184	108	
Inches	2	4.88	8.19	4.75	48.00
mm		124	208	121	

† Non-Shock

INNOVATION IN EVERY VALVE

The information presented on this sheet is correct at time of publication. Milwaukee Valve reserves the right to change design and/or materials without notice. For our Installation, Operation and Maintenance Manual and the most current product information go to www.milwaukeevalve.com. ⚠ State of California Prop 65
WARNING: Cancer and Reproductive Harm. For more information visit www.p65warnings.ca.gov.

MILWAUKEE VALVE