

BA-100ELD* 1/4"-2"

**Bronze Ball Valve
Two Piece
Standard Port (1"-2") Full Port (1/4"-3/4")
Safety Exhaust
Locking Handle
Blow-Out Proof Stem
MSS SP-110**

MATERIALS LIST

ITEM	PART	MATERIALS	ASTM SPEC.
1	Body	Cast Bronze	B584
2	Tailpiece	Brass	B283
		Cast Bronze (1 1/4" & up)	B584
3	Ball	Brass w/Hard Chrome Plating	B16
4	Seat	RPTFE, 15% Glass Filled	
5	Stem	Brass	B16
6	Thrust Washer	RPTFE, 25% Glass Filled	
7	Packing	PTFE	
8	Packing Nut	Brass	B16
9	Handle	Steel w/Zinc Plating	Commercial
10	Hand Grip	Vinyl	
11	Handle Nut	Steel w/Zinc Plating	Commercial

*Not intended for use in potable water.

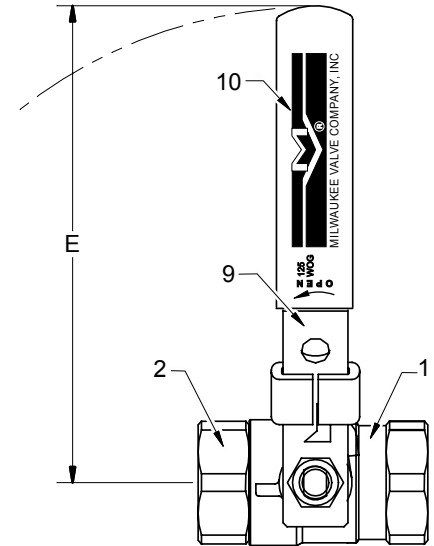

PRESSURE - TEMPERATURE DATA

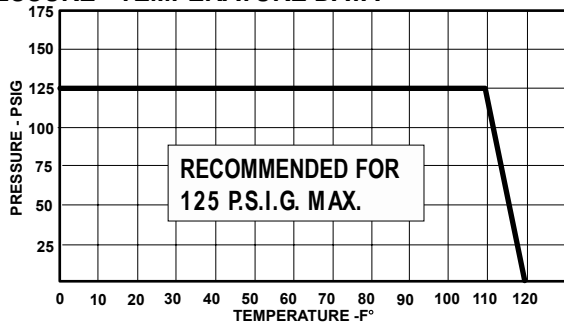

Note: Handle is shown in the open position. Ball is shown closed to illustrate vent feature.

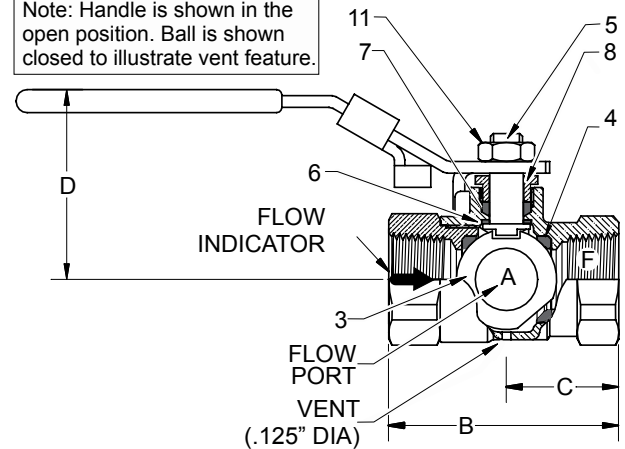

DIMENSIONS

	UNITS	1/4" DN10	3/8" DN10	1/2" DN15	3/4" DN20	1" DN25	1-1/4" DN32	1-1/2" DN40	2" DN50
A (DIA)	INCHES	0.38	0.38	0.5	0.76	0.88	1.06	1.31	1.56
	mm	10	10	13	19	22	27	33	40
B	INCHES	1.86	1.86	2.19	2.59	3.17	3.50	3.96	4.30
	mm	47	47	55	66	80	89	101	109
C	INCHES	1	1	1.10	1.30	1.58	1.74	1.97	2.15
	mm	25	25	27	33	40	44	50	55
D	INCHES	1.81	1.81	1.91	2.08	2.25	2.66	2.84	3.00
	mm	46	46	48	53	57	67	72	76
E	INCHES	3.82	3.82	3.82	4.84	4.84	6.35	6.35	7.20
	mm	97	97	97	123	123	161	161	183
F	THREAD SIZE	1/4" NPT	3/8" NPT	1/2" NPT	3/4" NPT	1" NPT	1-1/4" NPT	1-1/2" NPT	2" NPT
Cv		7	7	12	30	38	61	87	121

Note: DN (Diameter Nominal) = Metric equivalent size.

The information presented on this sheet is correct at time of publication. Milwaukee Valve reserves the right to change design and/or materials without notice. For our Installation, Operation and Maintenance Manual and the most current product information go to www.milwaukeevalve.com.
 ⚠ State of California Prop 65 **WARNING:** Cancer and Reproductive Harm. For more information visit www.p65warnings.ca.gov.

