

BA-300/300S* 1/4"-3"

**Bronze Ball Valve
Three Piece
Full Port
600 WOG/150 SWP (1)
Threaded Ends
Blow-Out Proof Stem
MSS SP-110**

MATERIALS LIST

ITEM	PART	MATERIALS	ASTM SPEC.
1	Body	Cast Bronze	B584
2	End Cap	Bronze	B584
3	Stem	Brass	B16
		316 Stainless Steel (2)	A276
4	Packing Nut	Brass	B16
5	Packing	PTFE	
6	Thrust Washer	RPTFE, 25% Glass Filled	
7	Ball	CP Brass	B16
		316 Stainless Steel (2)	A276
8	Seat	RPTFE, 15% Glass Filled	
9	O-Ring	Viton	Commercial
10	Handle	Steel w/Zinc Plating	Commercial
11	Handle Grip	Vinyl	Commercial
12	Handle Nut	Steel w/Zinc Plating	Commercial
13	Bolt	Steel w/Zinc Plating	Commercial
14	Nut	Steel w/Zinc Plating	Commercial

(1) Milwaukee Valve Company recommends the use of Stainless Steel ball and stem for steam applications. Please consult factory for more information.

(2) Ball and stem are stainless for 300S

*Not intended for use in potable water.

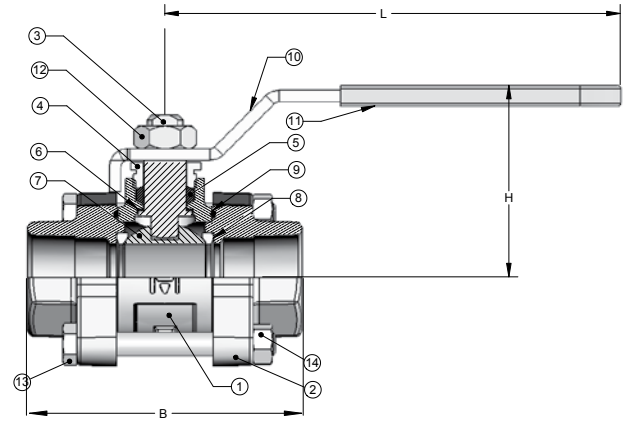

PRESSURE and TEMPERATURE CHART

VALVES RATED FOR VACUUM SERVICE TO 29 INCHES Hg.

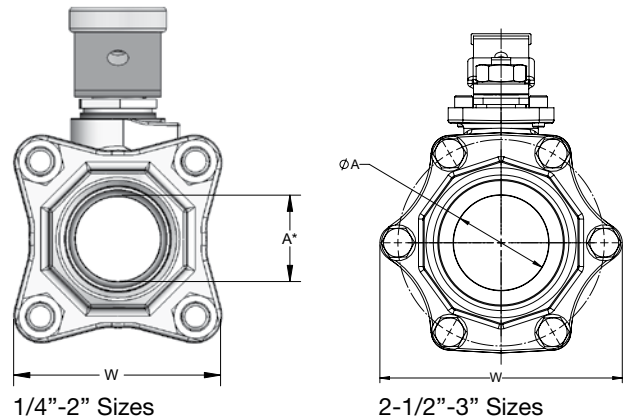
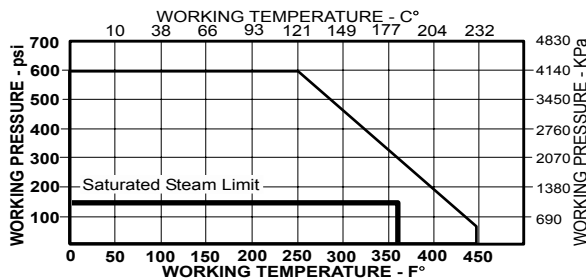

1/4"-2" Sizes

2-1/2"-3" Sizes

DIMENSIONS

	UNITS	1/4" DN6	3/8" DN10	1/2" DN15	3/4" DN20	1" D25	1-1/4" D32	1-1/2" D40	2" D50	2-1/2" DN 65	3" * DN 80
A	INCHES	0.50	0.50	0.50	0.75	1	1.25	1.50	2.00	2.50	2.50
	mm	13	13	13	19	25	32	38	51	64	64
B	INCHES	3.03	3.03	3.03	3.65	3.82	4.86	5.06	6.00	7.00	7.00
	mm	77	77	77	90	97	123	129	152	178	178
H	INCHES	1.65	1.65	1.65	2.24	2.65	2.86	3.03	3.26	4.09	4.09
	mm	42	42	42	57	67	73	77	83	104	104
L	INCHES	4.03	4.03	4.06	4.58	6.30	6.32	7.20	7.20	8.00	8.00
	mm	102	102	103	116	160	161	183	183	203	203
W	INCHES	1.95	1.95	1.95	2.19	2.48	3.00	3.13	3.78	6.25	6.25
	mm	50	50	50	56	63	76	80	96	159	159
F	THREAD SIZE	1/4" NPT	3/8" NPT	1/2" NPT	3/4" NPT	1" NPT	1-1/4" NPT	1-1/2" NPT	2" NPT	2-1/2" NPT	3" NPT
Cv		7	7	17	31	60	110	185	360	390	390

Note: DN (Diameter Nominal) = Metric equivalent size.

* 3" is Standard Port.

The information presented on this sheet is correct at time of publication. Milwaukee Valve reserves the right to change design and/or materials without notice. For our Installation, Operation and Maintenance Manual and the most current product information go to www.milwaukeevalve.com.

⚠ State of California Prop 65 **WARNING:** Cancer and Reproductive Harm. For more information visit www.p65warnings.ca.gov.



OPTIONS

BA100/150
BA300/350
BA400/450

TIH THE INSULATOR/MS Extension Handle

The **THE INSULATOR/MS** extension handle is designed to prevent condensation and other extraneous moisture from entering the insulated piping system, while also minimizing thermal energy loss from the system via metal extension tubes, levers, and similar parts.



The design incorporates a unique memory stop feature that requires no disassembly or removal of the handle to engage and make adjustments.

LO Locking Oval Handle

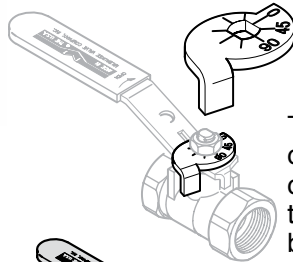
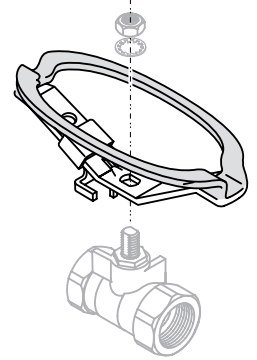

MS Memory Stop

The "MS" Memory Stop offers the convenience of a preset stop when the valve is used in a balancing application. The memory stop can be set from the full closed position, to any preset opening point.

SH Stainless Steel Handle

The "SH" handle option adds a 316 stainless steel handle and nut to a standard bronze ball valve. This option is intended for harsh environments like areas subject to salt water spray, high humidity, harsh cleaning chemicals, etc.

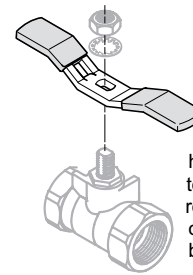
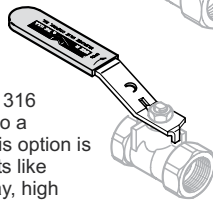

TH Tee Handle

Tee handles offer the same installation space savings as oval handles, with a slightly shorter end to end dimension. Tee handles require more handle force to operate, so accidental openings can be reduced.

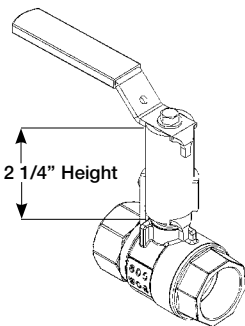

XM Extension Handle with Memory Stop

The "XM" stem extension is all-metallic with an adjustable memory stop. This option is designed for installations where pipe insulation would make standard handles inoperable. The adjustable memory stop allows the valve opening to be limited to a preset position. This option can be ordered with or without the memory stop.

OH & LO Milwaukee offers two styles of oval handles, standard oval and a padlocking oval design.

Oval handles can prevent accidental valve operations, since they have less projection than a lever handle, and require more turning force to operate. OSHA requires the use of oval handles in many installations for safety reasons. The locking handle design will accommodate a standard 5/16" pad-lock or other types of valve lockouts.

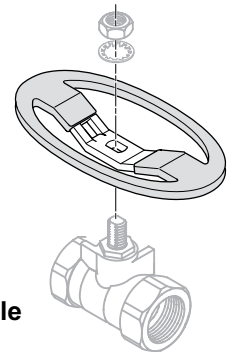

OH Oval Handle

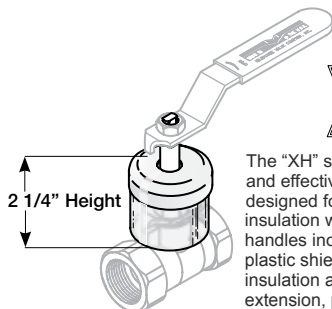

XH Extension Stem

The "XH" stem extension is simple and effective design. This option is designed for installations where pipe insulation would make standard handles inoperable. The external plastic shield helps to keep the insulation away from the stem extension, providing years of trouble free operation.

LD Locking Device

The "LD" Locking Handle offers the end user the security of a pad lockable handle. The handle can be locked in either the full open position, or full closed by adding a standard padlock. The locking handle design will accommodate a standard 5/16" pad-lock or other types of valve lockouts. The handle and locking device are also manufactured of stainless steel material for additional strength and corrosion resistance.

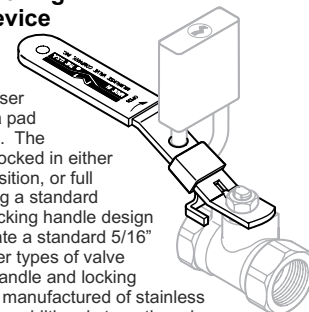

The information presented on this sheet is correct at time of publication. Milwaukee Valve reserves the right to change design and/or materials without notice. For our Installation, Operation and Maintenance Manual and the most current product information go to www.milwaukeevalve.com.
⚠ State of California Prop 65 **WARNING: Cancer and Reproductive Harm.** For more information visit www.p65warnings.ca.gov.

