

F-2974A 2"-12"

Iron Check Valve
125 SWP - 200 WOG †
Horizontal Swing • Flanged Ends
Bolted Cover
Conforms to: MSS SP-71

Flange shape and drilling to specification ASME B 16.1 (125 lb).

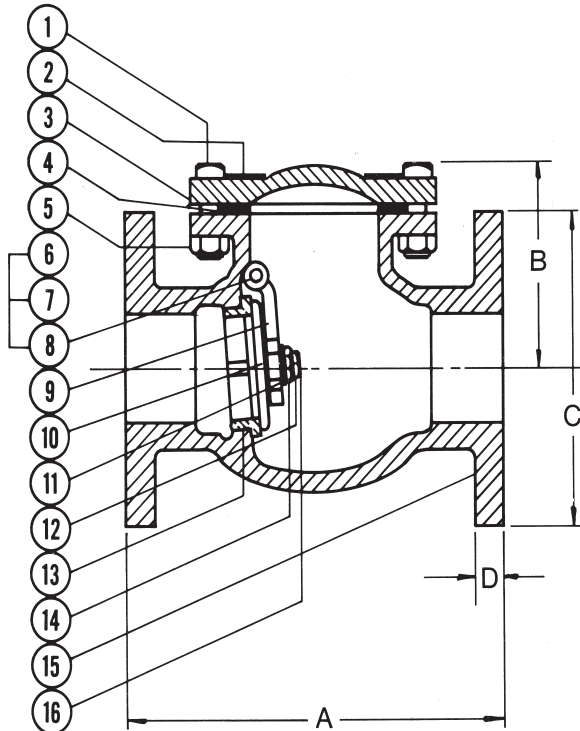

Note 1: On pump discharge, the preferred check valve is either an in-line spring loaded valve or a swing design with lever and weight. Install these valves as far as possible from the pump and elbows with a minimum distance of 5 times the pipe diameter.

Note 2: These iron body check valves may be installed in horizontal and vertical lines with upward flow or in intermediate position.

MATERIAL LIST			
No.	PART	MATERIAL	SPECIFICATION
1	Bolt	Steel	
2	Name Plate	Aluminum	
3	Cover	Cast Iron	ASTM A126, Class B
4	Cover Gasket	Aramid Fiber/NBR	
5	Nut	Steel	
6	Side Plug	Brass	ASTM B16
7	Gasket	Graphite	
8	Hanger Pin	SS 304	ASTM B16
9	Hanger	Ductile Iron	ASTM A536
10 ¹	Disc	Cast Iron	ASTM A126, Class B
11	Washer	Steel	
12	Cotter Pin	Carbon Steel Galvanized	
13	Seat Ring	Bronze	ASTM B 62
14	Disc Nut	Steel	ASTM A307
15	Body	Cast Iron	ASTM A126, Class B
16	Stud Bolt	Brass	ASTM B16

¹ Valve Disc-Cast iron with bronze disc face rings.

DIMENSIONS - INCHES/MILLIMETERS						
Units	Size	A	B	C	D	C _v
Inches mm	2	8.00 203	3.94 100	6.00 152	0.63 16	143
Inches mm	2 1/2	8.50 216	4.50 114	7.00 178	0.69 17	242
Inches mm	3	9.50 241	5.13 130	7.50 191	0.75 19	366
Inches mm	4	11.50 292	6.13 156	9.00 229	0.94 24	572
Inches mm	5	13.00 330	6.81 173	10.00 254	0.94 24	894
Inches mm	6	14.00 356	8.00 203	11.00 279	1.00 25	1287
Inches mm	8	19.50 495	9.44 240	13.50 343	1.13 29	2288
Inches mm	10	24.50 622	12.06 306	16.00 406	1.19 30	3574
Inches mm	12	27.50 699	16.13 410	19.00 483	1.25 32	5147

† Non-Shock

Note: Does not meet Senate Law S.3874



MILWAUKEE VALVE

The information presented on this sheet is correct at time of publication. Milwaukee Valve reserves the right to change design and/or materials without notice. For our Installation, Operation and Maintenance Manual and the most current product information go to www.milwaukeevalve.com. State of California Prop 65
WARNING: Cancer and Reproductive Harm. For more information visit www.p65warnings.ca.gov.