



H-x156 - Pro-Pal Ball Drain Strainers



H-x156W Series

Pro-Pal Ball Drain Strainer

Full Port Forged DZR Brass Ball Valve
w/ Hi-Flow Multi-Function Hose Drain,
Integral Y-Strainer (20 Mesh),
1/2" Plugged NPT Port
& Adjustable Packing Glands

Certifications

Certified to NSF/ANSI/CAN 61 & 372



	Size (in)	Item#	Weight (lbs)	CTN Qty	Case Qty	A	B	C		
FIP	1/2"	H-41562W	1.06	4	32	3.58	3.00	3.25	250 PSI CWP Max	200°F Max
	3/4"	H-41563W	1.64	2	24	4.30	3.00	3.75		
	1"	H-41564W	2.14	2	20	4.72	3.00	4.00		
	1 1/4"	H-41565W	3.44	2	12	5.75	3.50	4.50		
	<hr/>									
G-Thread	1"	H-G1564W	2.25	1	12	5.09	3.00	4.00	200 PSI CWP Max	200°F Max
	1 1/2"	H-G1566W	4.82	1	4	6.77	5.00	5.00		
	<hr/>									
Press	1/2"	H-81562W	1.16	2	24	5.09	3.00	3.25	250 PSI CWP Max	200°F Max
	3/4"	H-81563W	1.75	2	20	6.18	3.00	3.75		
	1"	H-81564W	2.29	2	12	6.46	3.00	4.00		
	1 1/4"	H-81565W	3.63	2	8	7.78	3.50	4.50		
	<hr/>									



NO.	DESCRIPTION	MATERIAL
1	Cap	Brass
2	Gasket	EPDM
3	Screw	Stainless Steel
4	Handle	Aluminum
5	Stem	Brass
6	Strap	PVC
7	Cap	Brass
8	Ball	Brass HCP
9	Seat	PTFE
10	Seat	PTFE
11	Packing	PTFE
12	Packing Gland	Brass
13	Body	Lead-Free DZR Brass
14	Stem	Brass
15	Ball	Brass HCP
16	Handle Nut	Stainless Steel
17	Cap	Lead-Free DZR Brass
18	Handle	Steel CP
19	O Ring	EPDM
20	strainer	Stainless Steel
21	1/2"NPT Plug	Lead-Free DZR Brass
22	Cap	Lead-Free DZR Brass
23	O Ring	EPDM
24	O Ring	EPDM
25	Packing	PTFE
26	Packing Gland	Brass

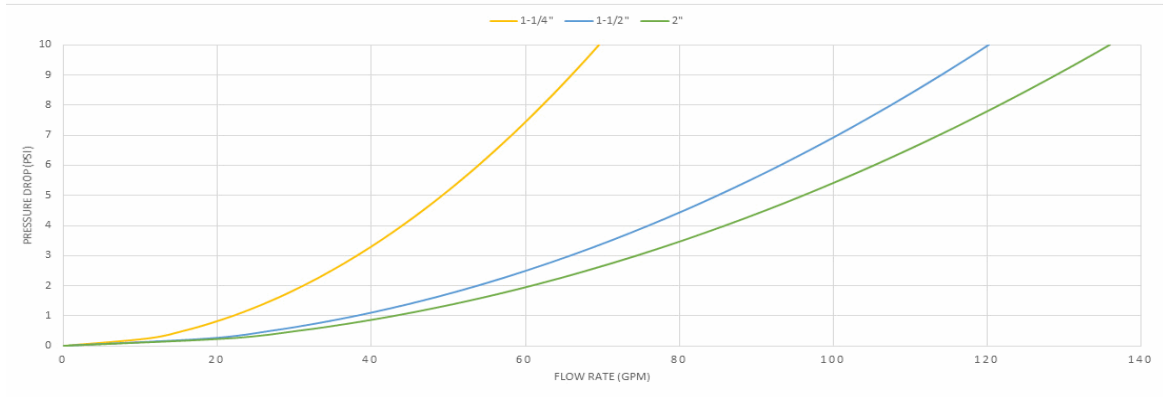
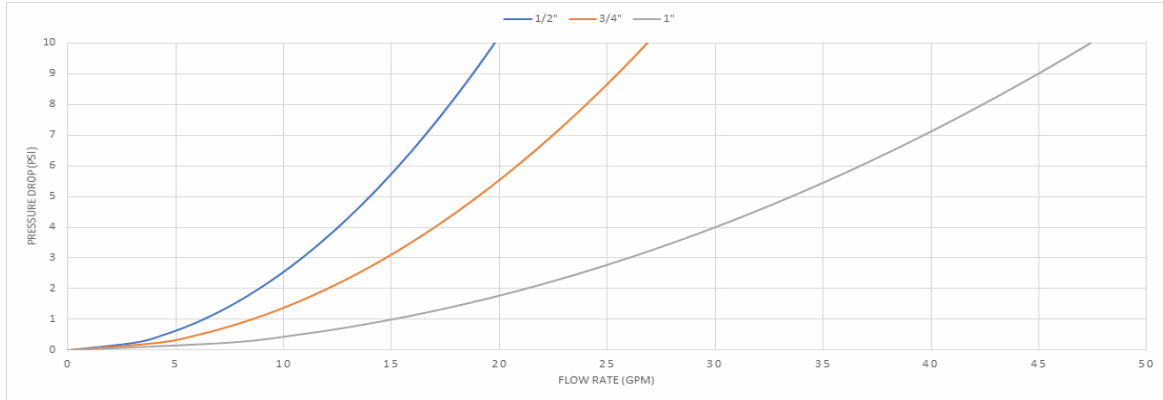
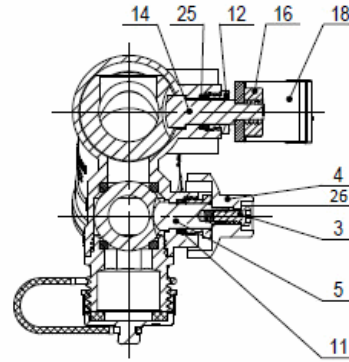
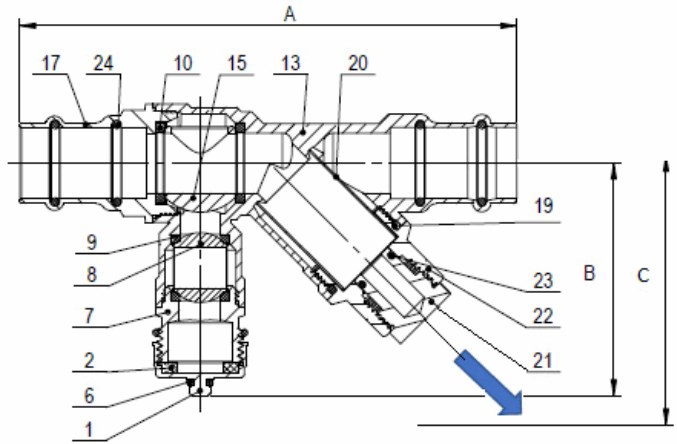

Specifications: Designed for use with water, oil, glycol mix in residential or commercial plumbing and heating systems. Threaded (NPT) ends comply with ANSI B1.20.1. Solder joint temperature ratings are per ASME B16.18 Annex A for 95-5 solder. Do not silver braze or overheat valves when soldering. G-threaded bodies require matching G-union fitting for installation. EPDM o-