



PS1201C, PS2401C Replacement Power Supply Kits for Electronic Air Cleaners

INSTALLATION INSTRUCTIONS

APPLICATION

These kits replace the power supplies used in F50, F52, F54, F55, F56, F57, F58, F59 and F70 Electronic Air Cleaners. See Table 1.

Each kit includes the power supply, leadwires and appropriate terminals. To maintain test button operation on F52 (one cell model only), the access door (ordered separately) must also be replaced.

IMPORTANT

These kits cannot be used for air cleaners with performance indicator circuits.

The power supply board in this kit has been calibrated to provide a selectable ionizer current output. Selection of the correct ionizer current is accomplished by selecting a jumper on P5. See Table 1. See Fig. 18 for location of P5.

Table 1. Power Supply Replacement Guide.

Electronic Air Cleaner					
Model	Voltage	Nominal Cell Size		P5 Ionizer Current (mA)	Replacement Power Supply
		in.	mm		
F50A,E	120 Vac	16 x 25	406 x 635	1.65	PS1201C01
		20 x 20	508 x 508	1.65	
		20 x 25	508 x 635	2.10	
		20 x 12-1/2	508 x 318	1.05	
	240 Vac	16 x 25	406 x 635	1.65	PS2401C00
		20 x 20	508 x 508	1.65	
		20 x 25	508 x 635	2.10	
		20 x 12-1/2	508 x 318	1.05	
220 Vac/50 Hz ^a	16 x 25	406 x 635	1.65		
F52C (one-cell)	120 Vac	20 x 12-1/2	508 x 318	1.05	PS1201C02
	220-240 Vac	20 x 12-1/2	508 x 318	1.05	PS2401C00
F52D (two-cell)	120 Vac	20 x 25	508 x 635	2.10	PS1201C02
	220-240 Vac	20 x 25	508 x 635	2.10	PS2401C00
F54C	120 Vac	20 x 25	508 x 635	2.10	PS1201C02
	220-240 Vac	20 x 25	508 x 635	2.10	PS2401C00
F55A,E	120 Vac	16 x 25	406 x 635	1.65	PS1201C02
		20 x 25	508 x 635	2.10	
	240 Vac	16 x 25	406 x 635	1.65	PS2401C00
		20 x 25	508 x 635	2.10	
F56A	120 Vac	16 x 12-1/2	406 x 318	0.25	PS1201C02
F57A (two-cell)	120 Vac	20 x 25	508 x 635	2.10	
F57B (one-cell)	120 Vac	20 x 12-1/2	508 x 318	1.05	
F57B	220-240V, 50 Hz	20 X 12-1/2	508 X 318	1.05	PS2401C00



Table 1. Power Supply Replacement Guide. (Continued)

Electronic Air Cleaner				P5 Ionizer Current (mA)	Replacement Power Supply
Model	Voltage	Nominal Cell Size			
		in.	mm		
F58A,E	120 Vac	16 x 25	406 x 635	1.65	PS1201C02
F59A	120 Vac	16 x 12-1/2	406 x 318	0.25	
	220 Vac/50 Hz ^a	16 x 12-1/2	406 x 318	0.25	PS2401C00
F70C	120 Vac	20 x 25	508 x 635	2.10	PS1201C02
F52F		12-1/2 x 20	317.5 x 508	1.05	PS1201C02
	120 Vac/60 Hz	20 x 25	508 x 635	2.1	PS1201C02

^aSpecial international model for 50 Hz.

INSTALLATION

When Installing this Product...

1. Read these instructions carefully. Failure to follow them could damage the product or cause a hazardous condition.
2. Check the ratings given in the instructions and on the product to make sure the product is suitable for your application.
3. Installer must be a trained, experienced service technician.
4. After installation is complete, check out product operation as provided in these instructions.



CAUTION

Electric Shock Hazard.
Can cause electrical shock or equipment damage.

Disconnect power before installing replacement power supply board.

To Remove Old Power Supply Board

- Open access door or grille. See Figs. 1 through 7.
- Open power box.

TWO-CELL MODEL

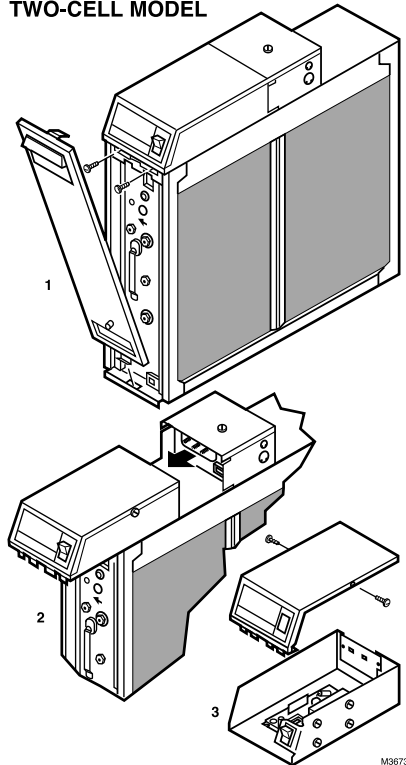

M3673

Fig. 1. Power supply location on F50A,E two-cell air cleaners.

ONE-CELL MODEL

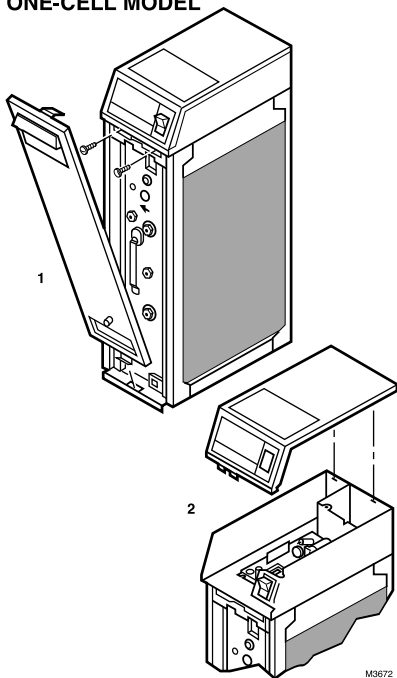

Fig. 2. Power supply location on F50A,E one-cell, F55A,E and F58A,E air cleaners (one-cell F50 shown).

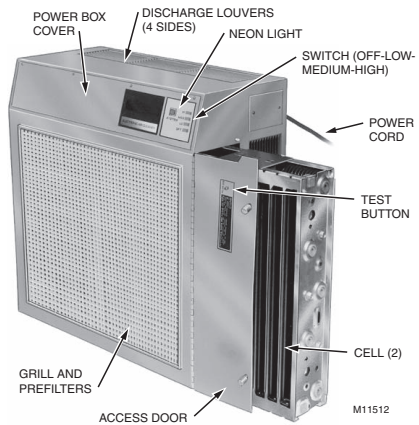

Fig. 4. Power box cover location on F54C. Remove four screws to access power supply.

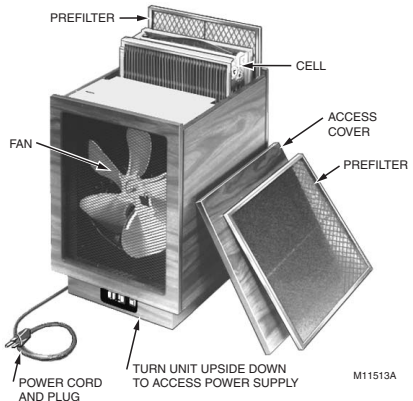

Fig. 5. Power supply location on F56A and F59A Air Cleaners.

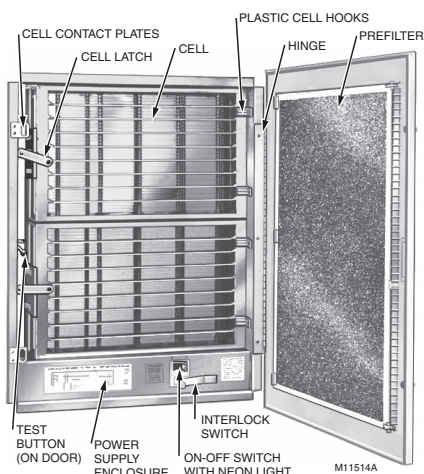

Fig. 3. Power supply enclosure location on F52C Air Cleaner. Open to access power supply.

To Remove W919 Power Supply

- Disconnect the red ionizer and black collector leads at the W919 quick-connects.
- Disconnect remaining leads at the quick-connects or Molex plug on the air cleaner.
- Remove and set aside the sheet metal screws holding the W919 in place. Discard the W919.

To Remove Solid State Power Supply

- Disconnect the leads from P1, P2, P3 and P4 on the old power supply.
- Remove and set aside the sheet metal screws holding the board in place.
- While holding the board, remove the leads from P5, P6 (if connected).
- Discard the old power supply.

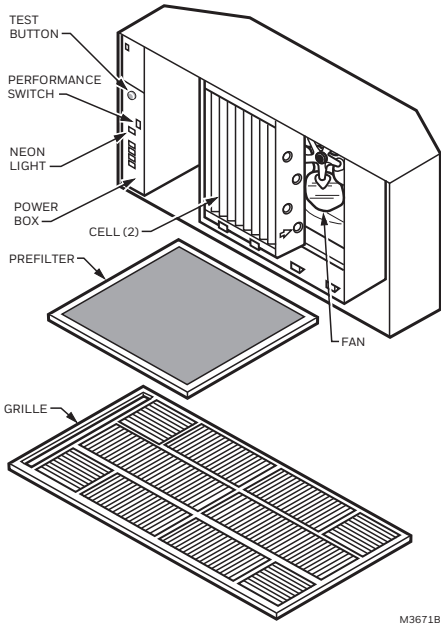

Fig. 6. Power box location on F57a Air Cleaners. Open to access power supply (two-cell F57 shown.)

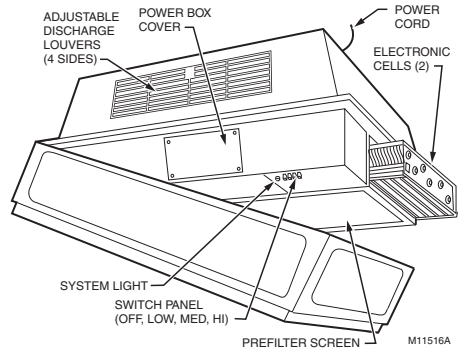
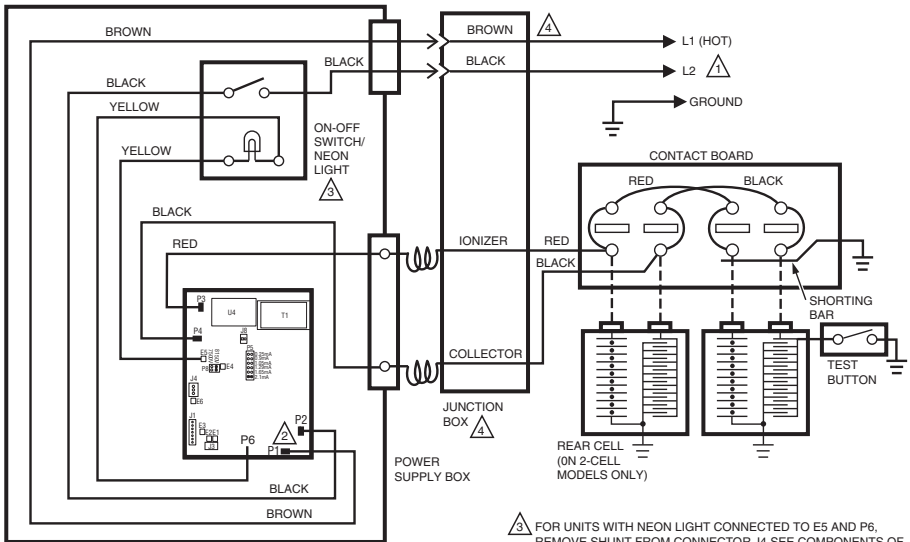

Fig. 7. Power supply location on F70 Air Cleaner.

Install New Power Supply

- When replacing W919, refer to appropriate wiring diagram; see Figs. 8 through 15. Some kits include more than one set of leadwires. Choose the leadwire set that corresponds to the colors shown in the wiring diagram. If your air cleaner has a Molex plug connector, choose the leadwire set with the matching Molex plug. You must use the thicker black lead for collector connections because it has heavier insulation to protect against electric shock from the high ionizer voltage.



⚠ POWER SUPPLY. PROVIDE DISCONNECT MEANS AND OVERLOAD PROTECTION AS REQUIRED.

⚠ P1, P2 TERMINALS ARE ON 120V MODELS ONLY. POWER CONNECTIONS ON 240V MODELS ARE TO QUICK-CONNECTS ON POWER SUPPLY TRANSFORMER. BROWN LEAD GOES TO TOP TERMINAL AND BLACK LEAD TO BOTTOM TERMINAL.

⚠ FOR UNITS WITH NEON LIGHT CONNECTED TO E5 AND P6. REMOVE SHUNT FROM CONNECTOR J4. SEE COMPONENTS OF REPLACEMENT POWER SUPPLY FIGURE 18.

⚠ SEPARATE JUNCTION BOX WITH LINE VOLTAGE PLUG AND SPRING CONTACTS ON F50 2-CELL MODELS ONLY. ON OTHER MODELS, LINE VOLTAGE CONNECTIONS ARE MADE IN POWER SUPPLY BOX.

M33802A

Fig. 8. F50A,E; F55,A,E; and F58A,E internal schematic.

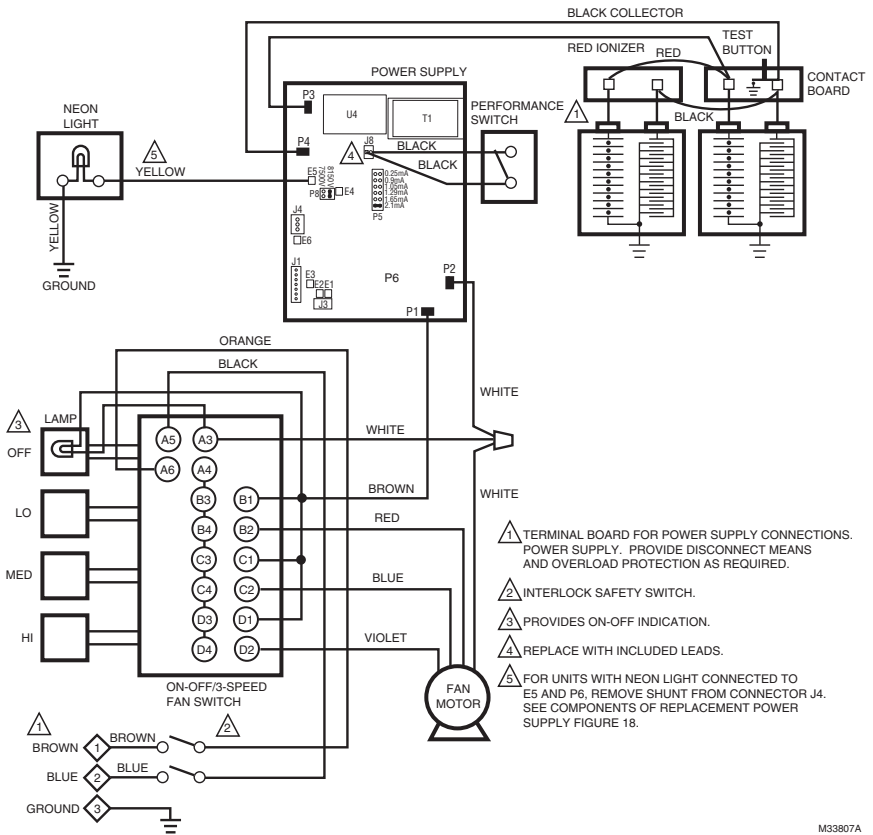

M33807A

Fig. 13. F57 240V model internal schematic. Early model without ON, WASH, and CHECK lights.

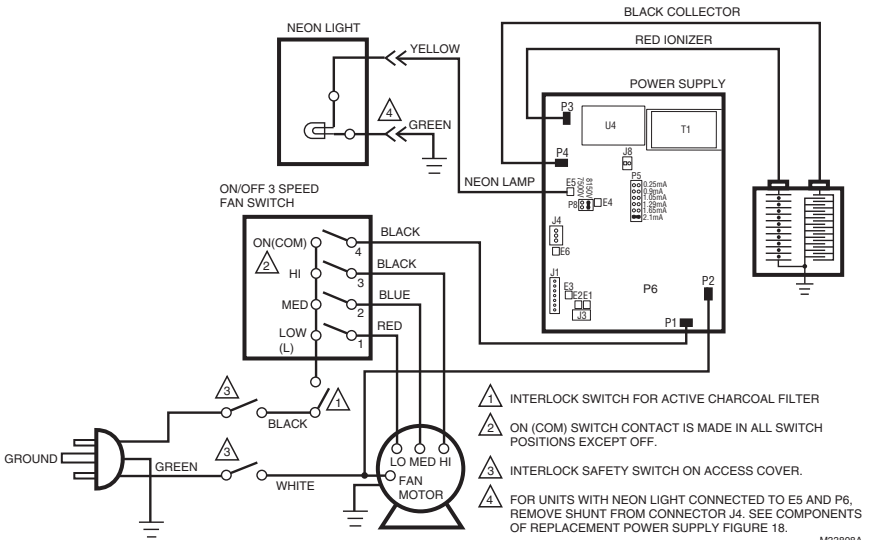

Fig. 14. F59A internal schematic.

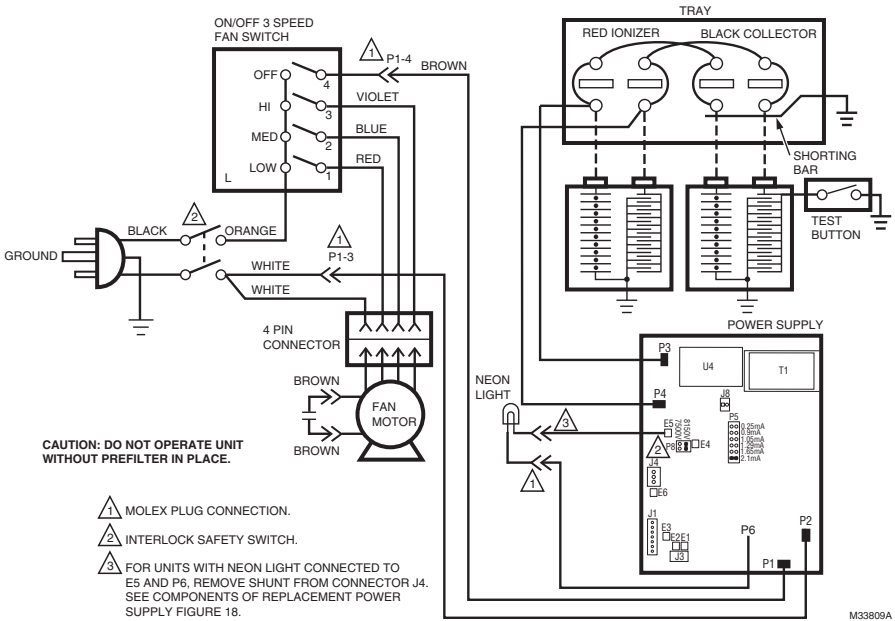

Fig. 15. F70C internal schematic.

- ❑ When replacing a solid state power supply, reuse the leadwires left in the air cleaner when removing the old power supply.

NOTE: The black leads to the performance switch must be replaced when installing an F57 power supply. See Figs. 12 and 13.

- ❑ On all models except the F56, F58 and F59, connect the leads for the neon light to E5 and P6 (connect E5 only on F56 and F59; on F58, connect the black lead with edge connectors on both ends to E5 and P6). Hold the small edge connectors with a pliers and push them into the slots on the board.
- ❑ On the F54C, move the red ionizer and black collector leads from one to the other contact board. See Fig. 16.
- ❑ When replacing the power supply in a F52E remove the rubber bumper from the bottom of the mounting base and place it in the same position on the base of the new power supply.
- ❑ When replacing the power supply in a F59 reinstall the sheet metal radio interference shield as shown in Fig. 17.
- ❑ Align the mounting holes and mount the new power supply in the air cleaner using the sheetmetal screws removed earlier. Be sure P1, P2 and P6 are toward the front (closest to the switch and neon light).
- ❑ Route the remaining leads so the red ionizer and black collector leads are separate from the power supply and light leads. Route all leads around, rather than over, the power supply board.

also connect on the air cleaner. See Figs. 8 through 15. You may need to cut some leads to the proper length and add a quick-connect terminal from the kit.

- ❑ Connect the Molex plug, if provided.

IMPORTANT

Do not splice ionizer and collector leads. These leads must be unbroken to avoid electrical shock through the connector or tape covering the splice.

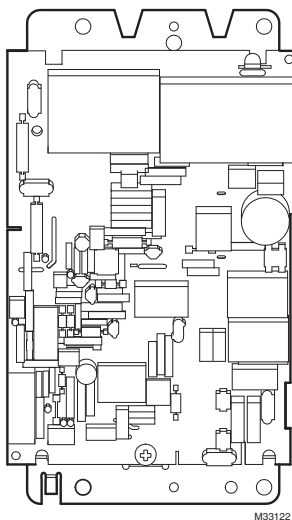

Fig. 17. Replace sheet metal radio interference shield on F59.

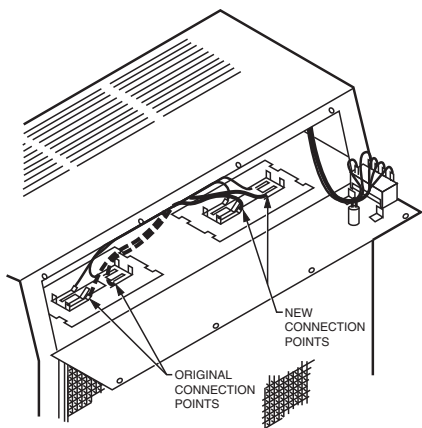

Fig. 16. Use the sheetmetal radio frequency interference shield with F56 and F59.

- ❑ Connect these leads to the quick-connect terminals on the new power supply and, if replacing W919,

CHECKOUT

⚠ WARNING
Electric Shock Hazard
Can cause personal injury or equipment damage.

The following procedures expose hazardous live parts. Disconnect power supply between checks and proceed carefully.

⚠ CAUTION
The following instructions are for use by qualified personnel only.

CAUTION
The following instructions are for use by qualified personnel only.

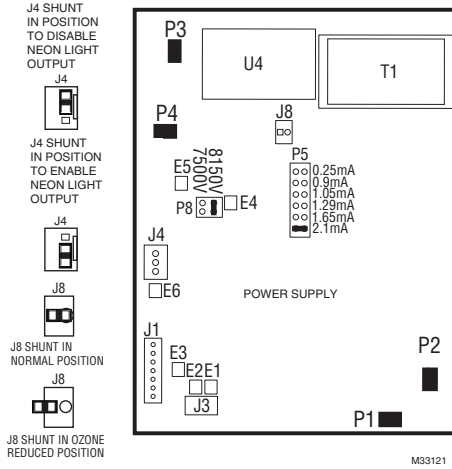

Fig. 18. Components of replacement power supply.

With all components in place, turn on the air cleaner switch and energize the system blower. Check the following points of operation:

1. Be sure the neon light (not provided on F58) is on.
2. Turn off the system blower. The neon light should go off. The neon light comes on to show that the air cleaner is energized and the high voltage power supply is working properly.
3. Turn the system blower back on. With the air cleaner energized, push the test button. A snapping sound indicates that collector voltage is available.
4. With a multispeed blower, repeat steps 1 through 3 for each fan speed.
5. With a meter, check the ionizer voltage between P3 (red lead) and ground, and the collector voltage between P4 (black lead) and ground. The correct voltages are printed on the label inside the access door.
6. If operation is not as described, refer to Troubleshooting and Service section.

TROUBLESHOOTING AND SERVICE

WARNING

Electric Shock Hazard
Can cause personal injury or equipment damage.

The following procedures expose hazardous live parts. Disconnect power supply between checks and proceed carefully.

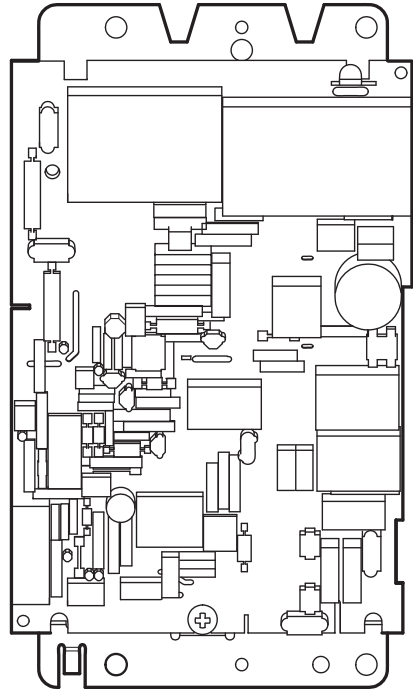

Fig. 19. Mounting plate.

Tools and Equipment

Troubleshooting the electronic air cleaner requires:

- Needlenose pliers for stringing ionizer wires and inserting edge connectors.
- Test meter with 15 kVdc probe or equivalent.

The electronic air cleaner Troubleshooting charts, Figs. 19 and 20, show how to quickly isolate a problem in the air cleaner. Although a meter is needed for some steps, see Fig. 21, the primary diagnostic tools are the neon light and the test button.

Test Button

When pushed, the test button shorts from a hot collector plate to ground. See internal schematics, Figs. 8 through 15. The resulting arcing sound indicates that high voltage is being supplied to the collector. The solid state power supply controls current flow to the collector so the arcing sound is only about half as loud as the sound on air cleaners with W919-style power supplies.

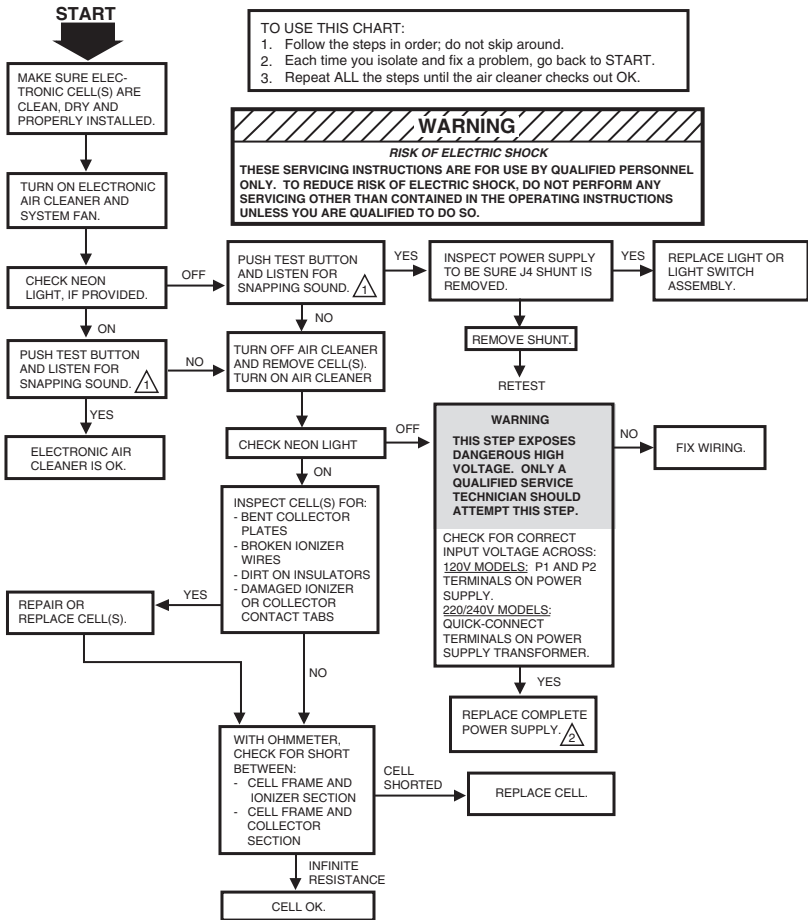

⚠️ THE SNAPPING SOUND ON THIS AIR CLEANER, WITH A SOLID STATE POWER SUPPLY, IS ABOUT HALF AS LOUD AS ON MODELS WITH THE W919 POWER SUPPLY.

⚠️ ELECTRONIC COMPONENTS ON POWER SUPPLY BOARD ARE NOT FIELD REPLACEABLE. ATTEMPTED SERVICE WILL DAMAGE BOARD.

M2812C

Fig. 20. Electrical troubleshooting procedure for electronic air cleaners in central systems.

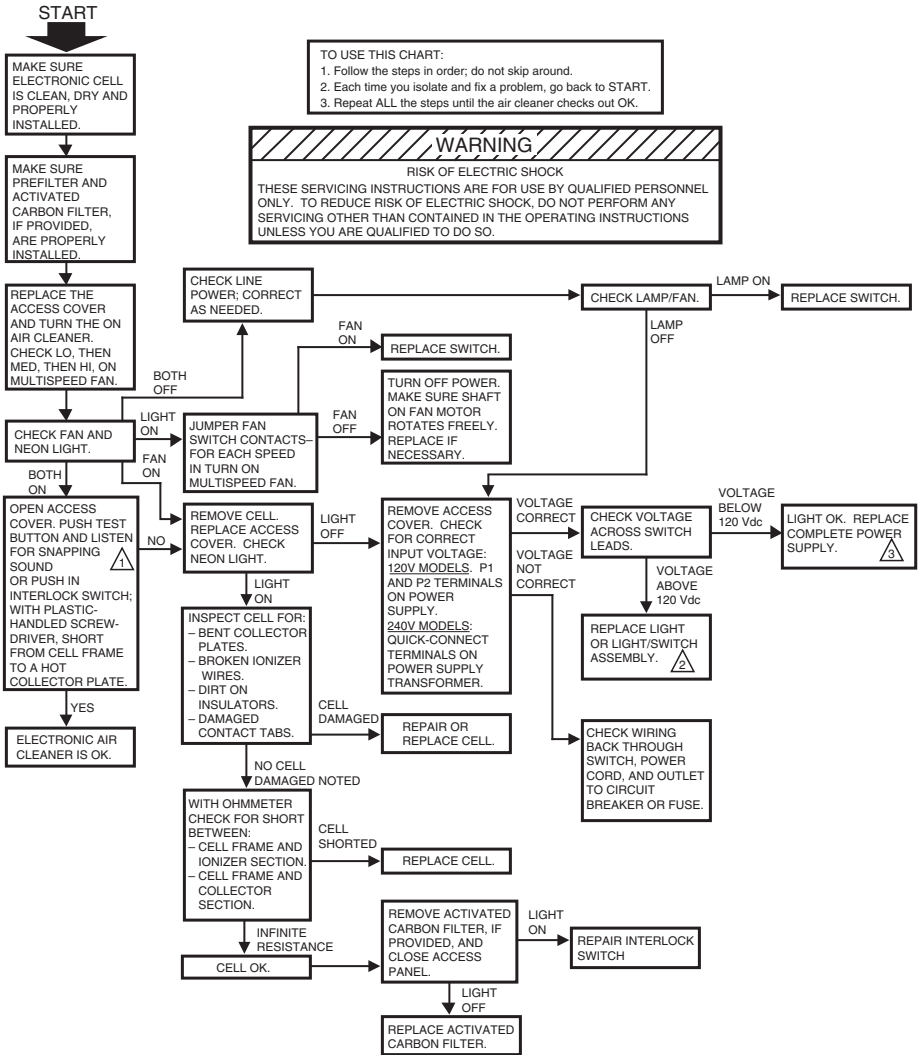

1 THE SNAPPING SOUND ON THIS AIR CLEANER, WITH A SOLID STATE POWER SUPPLY, IS ABOUT HALF AS LOUD AS ON MODELS WITH THE W919 POWER SUPPLY.

2 LIGHT/SWITCH ASSEMBLY MUST BE REPLACED TO ASSURE PROPER AIR CLEANER OPERATION.

3 ELECTRONIC COMPONENTS ON POWER SUPPLY BOARD ARE NOT FIELD REPLACEABLE. ATTEMPTED SERVICE WILL DAMAGE BOARD.

Fig. 21. Electrical troubleshooting procedure for electronic air cleaners with integral fan.

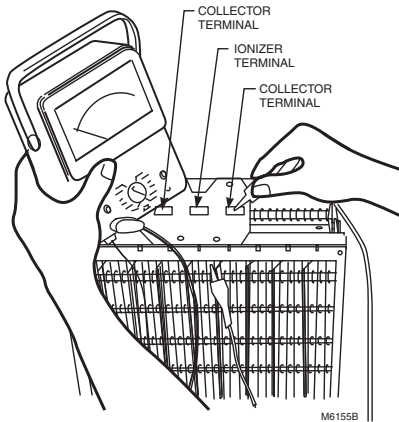

Fig. 22. Electrical troubleshooting procedure for electronic air cleaners in central systems.

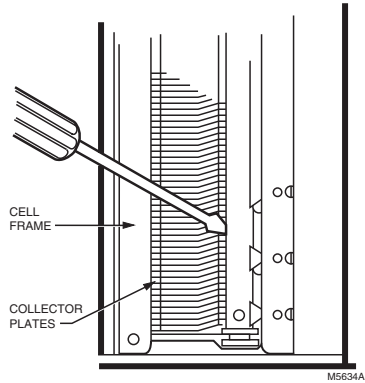

Fig. 24. On F56, F57, F59 and one cell F52, short from cell frame to hot collector plate to produce arcing.

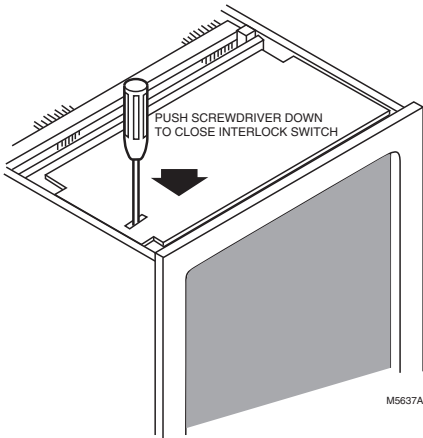

Fig. 23. On F56 and F59, insert screwdriver into the slot in the insulator to close the interlock switch.

Power Supply

CAUTION

**Electric Shock Hazard
Can cause personal injury**

Before opening the power supply cover, always disconnect power and open the access door or grille to discharge the high voltage power supply.

The solid state Power supply has no field-serviceable components. If troubleshooting indicates a power supply problem, replace the entire power supply. See Table 1.



CAUTION

Only a trained service technician should perform the following procedure.

On all other models, the procedure explained below will reduce ozone production about 20 to 25 percent and efficiency about 7 to 10 percent.

- a. Turn off power to the air cleaner.
- b. Open the access door or grille to discharge the high voltage power supply.
- c. If power supply is remote mounted, make sure access door or grille is open. Remove the power box cover.
- d. Locate J8 Shorting Bar on the power supply. See Fig. 18. Remove the shorting bar and reinstall on only one pin.

NOTE: The ozone will be reduced, but the shorting bar is available for reinstallation if needed.

- e. Replace power supply cover and access door or grille. Turn on power.

LIMITED TWO-YEAR WARRANTY

Resideo warrants this product, excluding battery, to be free from defects in workmanship or materials, under normal use and service, for a period of two (2) years from the date of first purchase by the original purchaser. If at any time during the warranty period the product is determined to be defective due to workmanship or materials, Resideo shall repair or replace it (at Resideo's option).

If the product is defective,

(i) return it, with a bill of sale or other dated proof of purchase, to the place from which you purchased it; or

(ii) call Resideo Customer Care at 1-800-468-1502. Customer Care will make the determination whether the product should be returned to the following address: Resideo Return Goods, 1985 Douglas Dr. N., Golden Valley, MN 55422, or whether a replacement product can be sent to you.

This warranty does not cover removal or reinstallation costs. This warranty shall not apply if it is shown by Resideo that the defect was caused by damage which occurred while the product was in the possession of a consumer.

Resideo's sole responsibility shall be to repair or replace the product within the terms stated above. RESIDEO SHALL NOT BE LIABLE FOR ANY LOSS OR DAMAGE OF ANY KIND, INCLUDING ANY INCIDENTAL OR CONSEQUENTIAL DAMAGES RESULTING, DIRECTLY OR INDIRECTLY, FROM ANY BREACH OF ANY WARRANTY, EXPRESS OR IMPLIED, OR ANY OTHER FAILURE OF THIS PRODUCT.

Some states do not allow the exclusion or limitation of incidental or consequential damages, so this limitation may not apply to you.

THIS WARRANTY IS THE ONLY EXPRESS WARRANTY RESIDEO MAKES ON THIS PRODUCT. THE DURATION OF ANY IMPLIED WARRANTIES, INCLUDING THE WARRANTIES OF MERCHANTABILITY AND FITNESS FOR A PARTICULAR PURPOSE, IS HEREBY LIMITED TO THE TWO YEAR DURATION OF THIS WARRANTY. Some states do not allow limitations on how long an implied warranty lasts, so the above limitation may not apply to you.

This warranty gives you specific legal rights, and you may have other rights which vary from state to state. If you have any questions concerning this warranty, please write Resideo Customer Care, 1985 Douglas Dr, Golden Valley, MN 55422 or call 1-800-468-1502.



resideo

Resideo Inc., 1985 Douglas Drive North,
Golden Valley, MN 55422

www.resideo.com 69-1138-07 M.S. Rev. 08-19 | Printed in United States

This product is manufactured by Resideo Technologies, Inc., Golden Valley, MN, 1-800-468-1502

©2019 Resideo Technologies, Inc. The Honeywell Home trademark is used under license from Honeywell International Inc. All rights reserved.