



396021 LP Gas and 396025 Natural Gas Conversion Kits

FOR VR82, VR83, AND SV9 SERIES OF
TWO-STAGE COMBINATION GAS CONTROLS

INSTALLATION INSTRUCTIONS

APPLICATION

The 396021 LP Conversion Kit changes VR81, VR82, VR83, and SV9 series of two-stage combination gas controls from regulated natural gas to regulated LP gas. The 396025 Natural Gas Conversion Kit changes VR81, VR82, VR83, and SV9 series of two-stage combination gas controls from regulated LP gas to natural gas. Kits include a stem/spring assembly and conversion label. Natural gas kits use a white stem and liquefied petroleum (LP) kits use a black stem. To use these kits, make sure the gas control is equipped with a two-stage pressure regulator (suffix letter Q or N).

INSTALLATION

When Installing this Product...

1. Read these instructions carefully. Failure to follow them could damage the product or cause a hazardous condition.
2. Check the ratings given in the instructions and on the product to make sure the product is suitable for your application.
3. Installer must be a trained, experienced service technician.
4. After installation is complete, check out product operation as provided in these instructions.

WARNING

**Fire or Explosion Hazard.
Can cause property damage, severe injury
or death.**

Follow these warnings exactly:

1. To avoid dangerous accumulation of fuel gas, turn off the gas supply at the appliance service valve before starting installation, and perform Gas Leak Test after installation is complete.
2. Do not force the gas control knob or switch. Use only your hand to turn the gas control knob or slide the gas control switch. Never use any tools. If gas control knob or switch will not operate by hand, then a qualified technician should replace the gas control. Force or attempted repair may result in fire or explosion.

WARNING

**Electrical Shock or Equipment Damage Hazard.
Can cause severe injury or death or short
equipment circuitry.**

Disconnect power supply before installation.

Always change the main and pilot burner orifices when converting from natural to LP gas or from LP to natural gas. Carefully follow appliance manufacturer specifications and instructions to assure proper appliance conversion. Gas controls are factory-set for natural (and manufactured) or LP gas. Do not attempt to use a gas control set for natural (or manufactured) gas on LP gas, or an gas control set for LP gas on natural (and manufactured) gas. Follow the appliance manufacturer instructions if available; otherwise, use these instructions as a guide.

To convert from one gas to another:

1. Turn off gas supply at the appliance service valve.
2. Remove the pressure regulator cover assembly. Refer to Fig. 1.
3. Remove the existing stem/spring assembly.
4. Insert the replacement stem/spring assembly.
5. Replace the pressure regulator cover assembly and tighten screws.
6. Mount conversion label on the gas control
7. Follow Start-Up and Checkout instructions.

STARTUP AND CHECKOUT

Control Knob Settings

NOTE: SmartValve™ System Controls SV9 series, VR8205S, T, and VR8215 gas controls do not have control knobs. They have an ON/OFF switch.

Control knob settings are as follows:

- a. OFF: Prevents pilot and main gas flow.
- b. PILOT (On standing pilot controls only): Permits pilot burner gas to flow when the red knob is held down or the thermocouple current is above the power unit dropout value.
- c. ON: Permits gas to flow through the control body to the main burner under control of the ignition system (and controls the pilot burner gas in intermittent pilot applications).



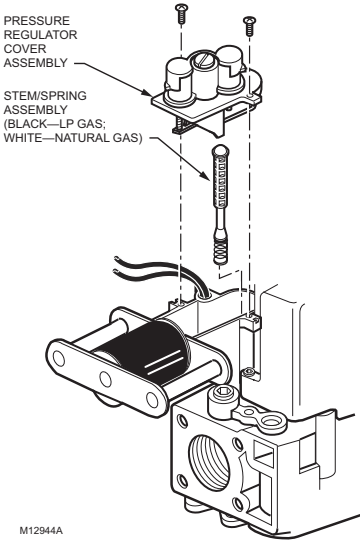

Fig. 1. Installing the conversion kit.

Perform Gas Leak Test

! WARNING

Fire or Explosion Hazard.
Can cause property damage, severe injury or death.
 Perform Gas Leak Test every time work is done on a gas system.

Gas Leak Test

1. Paint pipe connections upstream of the gas control with rich soap and water solution. Bubbles indicate a gas leak.
2. If a leak is detected, tighten the pipe connections.
3. Light the pilot burner and main burner as described in Lighting the Appliance. Stand clear of the main burner while lighting to prevent injury caused from hidden leaks that could cause flashback in the appliance vestibule.
4. With the main burner in operation, paint the pipe joints (including adapters) and the control inlet and outlet with a rich soap and water solution.
5. If another leak is detected, tighten the adapter screws, joints, and pipe connections.
6. Replace the part if a leak cannot be stopped.

Lighting the Appliance

Follow the appliance manufacturer instructions, if available, for lighting the pilot burner and main burner. If the manufacturer instructions are not available, use the following information.

! WARNING



Fire or Explosion Hazard.
Can cause property damage, severe injury, or death.
 Stand away from the main burner while lighting, because flashbacks caused by hidden gas leaks can cause property damage, injury or death.

For Direct Ignition and Intermittent Pilot Systems

1. Slide the gas valve switch or rotate the gas control knob to ON.
2. Follow the appliance manufacturer instructions or adjust the thermostat setting to call for heat. Do not try to manually light the pilot or the main burner.

Check and Adjust Pilot Flame

The pilot flame should envelop 3/8 to 1/2 in. (10 to 13 mm) of the tip of the thermocouple in Standing Pilot applications or flame rod in Intermittent Pilot applications. It should also be in continual contact with the ground electrode if this is an intermittent pilot application. See Fig. 2. If the pilot flame is small or lazy, or does not touch the ground electrode or thermocouple, the inlet gas pressure may be too low, or the pilot orifice may be partially clogged. Check and repair as necessary. If the pilot flame is hard and noisy, the inlet gas pressure may be too high. The intermittent pilot and standing pilot gas valves have a pilot adjustment mechanism to reduce the pilot flow if necessary. If pilot adjustment is necessary, proceed as follows:

1. Remove pilot adjustment cover screw. See Fig. 3 and 4.
2. The pilot adjustment is shipped at the full pilot gas flow rate. Using a screwdriver, turn the inner adjustment screw clockwise  if the inlet pressure is too high. Turn the inner adjustment screw clockwise  to decrease or counterclockwise  to increase pilot flame.
3. Replace the cover screw after the adjustment to prevent gas leakage.

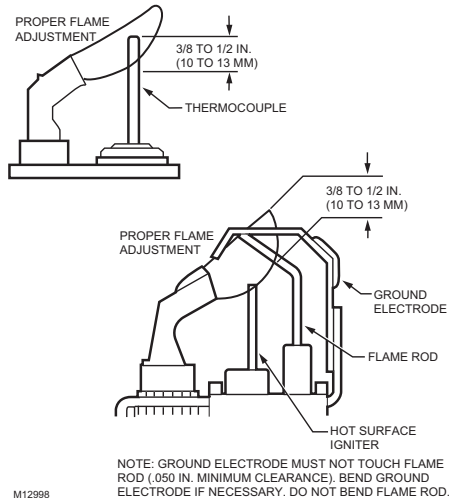

Fig. 2. Proper flame adjustment.

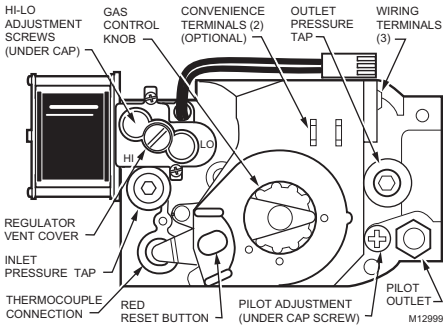

Fig. 3. Top view of VR82, VR83, series of two-stage combination gas controls.

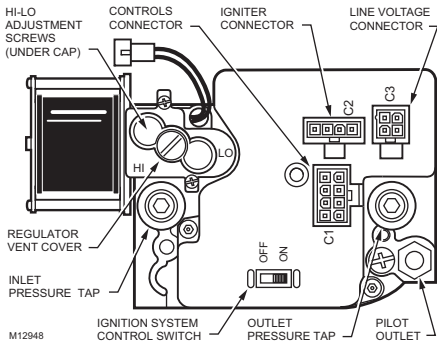

Fig. 4. Top view of SV9 series of two-stage combination gas controls.

Check and Adjust Gas Input and Burner Ignition

IMPORTANT

1. Do not exceed input rating stamped on appliance nameplate, or manufacturer recommended burner orifice pressure for size orifice(s) used. Make certain primary air supply to main burner is properly adjusted for complete combustion. Follow appliance manufacturer instructions.
2. IF CHECKING GAS INPUT BY CLOCKING GAS METER: Make certain there is no gas flow through the meter other than to the appliance being checked. Other appliances must remain off with the pilots extinguished (or deduct the consumption from the meter reading). Convert flow rate to Btuh as described in form 70-2602, Gas Controls Handbook, and compare to Btuh input rating on appliance nameplate.
3. IF CHECKING GAS INPUT WITH MANOMETER: Make sure the gas control knob or the ignition control switch is in the OFF position before removing outlet pressure tap plug to connect manometer (pressure gauge). Also move the gas control knob or the ignition system control switch to the OFF position when removing the gauge and replacing the plug. Before removing the inlet pressure tap plug, shut off the gas supply at the manual valve in the gas piping to

the appliance or, for LP, at the tank. Also shut off the gas supply before disconnecting the manometer and replacing the plug. Repeat the Gas Leak Test at the plug with the main burner operating.

NOTE: Check the inlet pressure before adjusting the pressure regulator.

Two-stage regulator models require that you check and adjust both high and low pressure regulator settings. Two-stage appliance operating sequences vary, consult the appliance manufacturer instructions for the specific operating sequence and regulator adjustment procedures for the appliance in which the control is installed.





Two-Stage VR82 and VR83 Models

1. Set appliance to operate on high.
2. Carefully check the main burner lightoff. Make sure that the main burner lights smoothly and that all ports remain lit.
3. Check the full rate (high) manifold pressure listed on the appliance nameplate for high pressure. The gas control full rate outlet pressure should match this rating.
4. With main burner operating, check the gas control flow rate using the meter clocking method or check pressure using a manometer connected to the outlet pressure tap on the gas control. See Fig. 3.
5. If necessary, adjust the high pressure regulator to match the appliance rating. See Table 1 and 2 for factory-set nominal outlet pressure and adjustment range.
 - a. Remove the pressure regulator adjustment cap (Fig. 3).
 - b. Using a screwdriver, turn the inner adjustment screw for HI pressure clockwise to increase or counterclockwise to decrease the gas pressure to the burner.
6. After high pressure has been checked, check low pressure regulation. Two-stage appliance operating sequences vary. Consult the appliance manufacturers instructions for the specific operating sequence and regulator adjustment procedure for the appliance in which the control is installed and for instructions on how to prevent the control from moving to high stage while checking the low pressure regulator setting.
7. Check the low rate manifold pressure listed on the appliance nameplate. Gas control low rate outlet pressure should match this rating.
8. With main burner operating, check the gas control flow rate as before (using the meter clocking method or check pressure using a manometer connected to the outlet pressure tap on the control).
9. If necessary, adjust the low pressure regulator to match the appliance rating. See Tables 1 and 2 for factory-set nominal outlet pressure and adjustment range.
 - a. Remove the pressure regulator adjustment cap (Fig. 3).
 - b. Using a screwdriver, turn the inner adjustment screw for LO pressure clockwise to increase or counterclockwise to decrease the gas pressure to the burner.
10. Once high and low pressure have been checked and adjusted, replace pressure regulator adjustment cap. If the desired outlet pressure or flow rate cannot be achieved by adjusting the gas control, check the control inlet pressure using a manometer at the inlet pressure tap of the control.

If the inlet pressure is in the nominal range (see Table 1 and 2), replace the gas control. Otherwise, take the necessary steps to provide proper gas pressure to the control.

Two-Stage SmartValve Controls

The regulator adjustment instruction for a two-stage SmartValve™ System Control is as follows:

1. Set thermostat 10 degrees above room temperature.
2. Carefully check the main burner lightoff. Make sure that the main burner lights smoothly and that all ports remain lit.
3. Wait for control to move to high pressure (second stage) and then check the full rate manifold pressure listed on the appliance nameplate for high pressure. The gas control full rate outlet pressure should match this rating.
4. With main burner operating, check the gas control flow rate using the meter clocking method or check pressure using a manometer connected to the outlet pressure tap on the control. See Fig. 4.
5. If necessary, adjust the high pressure regulator to match the appliance rating. See Tables 1 and 2 for factory-set nominal outlet pressure and adjustment range.
 - a. Remove the pressure regulator adjustment cap (Fig. 4).
 - b. Using a screwdriver, turn the inner adjustment screw for HI pressure clockwise  to increase or counterclockwise  to decrease the gas pressure to the burner.
6. After high pressure is checked, check low pressure regulation by removing the wire from terminal W2 of the ST9162 Fan Timer (to prevent ignition control from moving to high stage).
7. Check the low rate manifold pressure listed on the appliance nameplate. Gas control low rate outlet pressure should match this rating.
8. With main burner operating, check the control flow rate as before (using the meter clocking method or check pressure using a manometer connected to the outlet pressure tap on the control).
9. If necessary, adjust the low pressure regulator to match the appliance rating. See Tables 1 and 2 for factory-set nominal outlet pressure and adjustment range.
 - a. Remove the pressure regulator adjustment cap (Fig. 4).
 - b. Using a screwdriver, turn the inner adjustment screw for LO pressure clockwise  to increase or counterclockwise  to decrease the gas pressure to the burner.
10. Once high and low pressure have been checked and adjusted, replace pressure regulator adjustment cap. If the desired outlet pressure or flow rate cannot be achieved by adjusting the gas control, check the gas control inlet pressure using a manometer at the inlet pressure tap of the gas control. If the inlet pressure is in the nominal range (see Tables 1 and 2), replace the gas control. Otherwise, take the necessary steps to provide proper gas pressure to the control.

Checkout

1. Make certain the primary air supply to the main burner is properly adjusted for complete combustion at the final pressure regulator setting. The main burner must light reliably under all conditions.
2. Place the system in operation and observe through at least one complete cycle to assure all controls are operating properly.
3. If manometer (pressure gauge) method is used, perform Gas Leak Test at inlet and outlet pressure tap plugs.
4. Make certain the conversion label is applied to the gas control, heating appliance, and any other controls to show conversion to a new type of gas.

Table 1. Pressure Regulator Specification Pressures (in. wc).

Model Type	Type of Gas	Nominal Inlet Pressure Range	Factory Set Nominal Outlet Pressure		Setting Range
			Full Rate		Full Rate
Two-stage	NAT (White Stem)	5.0-7.0	1.7 Low 3.5 High	0.9-3.0 Low 3.0-5.0 High	
	LP (Black Stem)	12.0-14.0	4.9 Low 10.0 High	2.5-7.0 Low 8.0-11.0 High	

Table 2. Pressure Regulator Specification Pressures (kPa).

Model Type	Type of Gas	Nominal Inlet Pressure Range	Factory Set Nominal Outlet Pressure		Setting Range
			Full Rate		Full Rate
Two-stage	NAT (White Stem)	1.2-1.7	0.48 Low 0.9 High	0.37-0.75 Low 0.75-1.2 High	
	LP (Black Stem)	2.9-3.9	1.2 Low 2.5 High	0.9-1.4 Low 2.0-2.5 High	



Resideo Technologies, Inc.
1985 Douglas Drive North, Golden Valley, MN 55422
1-800-468-1502

www.resideo.com 69-1238-05 M.S. Rev. 06-20 | Printed in United States