



# 3-Way Balanced Hydronic Valves

## VC SERIES

### INSTALLATION INSTRUCTIONS



These two position 3 way hydronic valves are intended for use in a normal indoor environment to control the flow of hot and/or cold water, or glycol solution to 50% concentration.

They consist of an actuator, valve and replaceable valve cartridge assembly. These valves can be piped for either diverting or mixing valve applications in central heating and/or cooling systems; or for individual fan coil, radiator or convector applications.

Depending on the model selected they can be controlled by either a low or line voltage SPST or SPDT controller, such as a room thermostat, aquastat or flow switch.

## SPECIFICATIONS

The specifications following are nominal and conform to generally accepted industry standards. Resideo is not responsible for damages resulting from misapplications of its products.

Voltage:	Color coded label
24V 50Hz Model	Blue
24V 60Hz Model	Blue
100-130 V; 50-60 Hz Model	Black
200-240 V; 50-60 Hz Model	Red

**Power consumption:** 6 Watts Max. at nominal Voltage (during valve position change). Use 24 V Class 2 transformer. Provide 6 VA for transformer and connection wire sizing.

**Maximum Duty Cycle:** 15%

**End switch rating:**

2.2 A inductive from 5 to 110 Vac,  
1.0 A inductive above 110 to 277 Vac.  
Min. DC switching capability: 5 mA @ 24 Vdc

**Nominal timing:** Valve opens in 6 seconds @ 60 Hz (20% longer @ 50 Hz)

**Electrical termination:**

Available in 2 versions:  
(1) Molex™ (header # 39-30-1060). Requires mating connector (receptacle/housing # 39-01-2060). OR  
(2) With integral 1 meter [nominal 39"] leadwire cable.

**Operating ambient temperature:** 0 to 65°C [32 to 150°F]  
Except VC2114, VC2714, VC8114 & VC8714, are 0 to 60° C [32 to 140°F]

**Shipping & storage temperature:** -40 to +65°C [-40 to +150°F]

**Atmosphere:** non-corrosive, non-explosive

**Min. & max. fluid temperatures:** 1° to 95°C [34°to 203°F]. (Short duration peak: 120°C [248°F])

**Operating pressure differential:** Max. - 4 Bar [60 psi]

**Pressure rating:**

Static - 20 Bar [300 psi]  
Burst - 100 Bar [1500 psi]

**Valve material:** Body of brass; cartridge of Ryton® (polyphenylene sulphide), Noryl® (polyphenylene oxide) and Fortron®; O-ring seals of EPDM rubber; stainless steel stem.

**Dimensions / pipe fitting sizes / flow ratings (nominal Cv):** See Diagram.

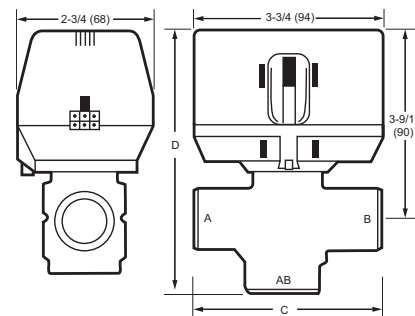
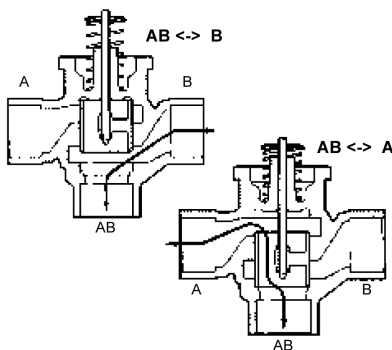

**Table 1. Nominal dimensions in mm and inches**

Dimensions Pipe Fitting Sizes	C		D		Cv (nominal)	
	mm	inches	mm	inches	6000	6100
3/8" Flare (no adapter)	98	3 - 7/8	136	5-11/32	3.0	2.7
1/2" Sweat	98	3 - 7/8	136	5-11/32	4.2	3.8
1/2" Flare (no adapter)	98	3 - 7/8	136	5-11/32	4.0	3.8
1/2" Inverted Flare (no adapter)	98	3 - 7/8	136	5-11/32	4.2	4.2
1/2" BSPP (int.), 15 MM Comp.	98	3 - 7/8	136	5-11/32	4.0	3.7
1/2" BSPT (int.)	98	3 - 7/8	136	5-11/32	4.0	3.8
1/2" NPT (int.)	98	3 - 7/8	136	5-11/32	4.0	3.7
3/4" BSPP (int.)	94	3-11/16	130	5-3/32	8.2	6.9
3/4" BSPT (int.)	94	3-11/16	130	5-3/32	8.2	6.2
3/4" BSPP (ext.)	94	3-11/16	130	5-3/32	8.0	6.7
3/4" NPT (int.)	94	3-11/16	130	5-3/32	8.6	6.6
3/4" Sweat	94	3-11/16	132	5-3/16	7.5	5.9
22 MM* Compression	112	4-7/16	140	5-1/2	8.3	6.9
1" BSPP (int.)	94	3-11/16	136	5-11/32	9.0	7.5
1" BSPP (ext.)	94	3-11/16	136	5-11/32	9.0	7.9
1" BSPT (int.)	94	3-11/16	136	5-11/32	9.0	8.1
1" NPT (int.)	94	3-11/16	136	5-11/32	9.0	8.6
1" Sweat	94	3-11/16	136	5-11/32	9.0	6.6
28 MM* Compression	116	4-9/16	147	5-13/16	9.0	7.5

\*Includes compression nuts and olives

**Flow:** Bottom port is marked AB. End ports are marked A & B. Port A is closed and port B open with the stem up position (Figure 1). Flow can be A or B to AB for mixing, or AB to A or B for diverting.



**Fig. 1. Fluid flow of directional 3-way valve**

### MANUAL OPENER

The manual opener can be manipulated only when in the up position. The "A" port can be manually opened by firmly pushing the red manual lever down to midway and in. In this position both the "A" and "B" ports are open, and with auxiliary switch models the switch is closed. This "manual open" position may be used for filling, venting, or draining the system, or for opening the valve in case of power failure. The valve can be restored manually to the closed position by depressing the red manual lever lightly and then pulling the lever out. The valve and actuator will return to the automatic position when power is restored.

**NOTE:** If the valve is powered open, it can not be manually closed unless actuator is removed.

# INSTALLATION

## When Installing This Product...

1. Read these instructions carefully. Failure to follow them could damage the product or cause a hazardous condition.
2. Check the ratings given in the instructions and on the product to make sure the product is suitable for your application.
3. Installer must be a trained, experienced service-person.
4. Always conduct a thorough checkout when installation is completed.
5. While not necessary to remove the actuator from the body, it can be removed for ease of installation. The actuator can be installed in any position to suit the most convenient wiring mode.
6. An extra 25 mm head clearance is required to remove the actuator.



## CAUTION

**Disconnect power supply before connecting wiring to prevent electrical shock and equipment damage.**

**On 24V systems, never jumper the valve coil terminals, even temporarily. This may damage the thermostat.**

## PLUMBING

### IMPORTANT

*Do not use boiler additives, solder flux and wetted materials which are petroleum based or contain mineral oil, hydrocarbons, or ethylene glycol acetate. Compounds which can be used, with minimum 50% water dilution, are diethylene glycol, ethylene glycol, and propylene glycol (antifreeze solutions)*

*Put the VC actuator manual lever in the manual open or fully open (down) position to allow initial system flushing with the actuator mounted. This may be done without electrical hook-up. Alternatively, reusable flush caps, part #272866B, may be purchased separately for use in initial flushing of dirty hydronic systems.*

The valve may be plumbed in any angle but preferably not with the actuator below the horizontal level of valve body. Make sure there is enough room around the actuator for servicing or replacement.

For use in diverting applications, the valve is installed with the flow water entering through bottom port AB, and diverting through end ports A or B. In mixing applications, the valve is installed with inlet to A or B and outlet through AB.

Mount the valve directly in the tube or pipe. Do not grip the actuator while making and tightening up plumbing connections. Either hold valve body in your hand or attach adjustable spanner (38 mm or 1-1/2") across hexagonal or flat faces on the valve body. (Figure 2)

If assembling valve train on a bench, take care not to deform the body with vice. Do not place the raised "H" logo between the jaws of the vice. Excess jaw force can deform the body.

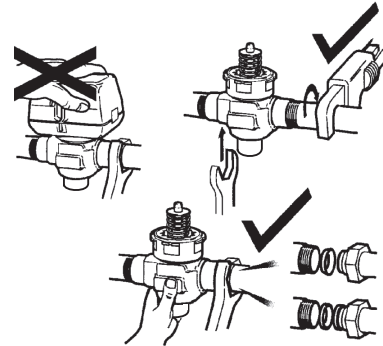

**Fig. 2. Plumbing of the VC valve.**

## COMPRESSION MODELS

For compression fitted models, tighten the compression nuts enough to make a watertight seal. **TAKE CARE NOT TO OVER TIGHTEN.** Maximum torque limit is 33 ft-lb for the 22 mm compression fitting, and 48 ft-lb for the 28 mm compression fitting.

## SWEAT MODELS

On sweat fitted valves, the cartridge is shipped loose to avoid being damaged during the solder operation.

1. Remove valve actuator from body and solder the connecting pipes in accordance with normal soldering practices.
2. After soldering and valve has cooled, remove cartridge assembly from plastic bag, insert into the valve body and tighten down with enclosed wrench until it bottoms out. **DO NOT OVER TIGHTEN** (maximum torque is 40 in-lb). The top surface of the cartridge will be flush with the top edge of the body casting.
3. Replace valve actuator.

## TO INSTALL OR REPLACE ACTUATOR

**NOTE:** Installation of a new actuator does not require draining the system provided the valve body and valve cartridge assembly remain in the pipeline.

1. Check replacement part number and voltage ratings for match with old device.
2. Disconnect power supply before servicing to avoid electrical shock or equipment damage.
3. Disconnect leadwires to actuator, or depress tab on Molex™ connector and remove. Where appropriate, label wires for rewiring.
4. The actuator head is automatically latched to the valve. To remove, press up on the latch mechanism located directly below the red manual open lever with thumb (See Figure 3). Simultaneously press the actuator down towards the body with moderate hand force and turn the actuator counter-clockwise by 1/8 turn (45 degrees). Lift actuator off the valve body.

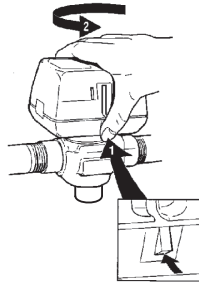

**Fig. 3. Actuator Head Removal.**

NOTE: The actuator can also be installed at right angles to the valve body but in this position the latch mechanism is not engaged.

5. Install the new actuator by reversing the process in (4).
6. Reconnect leadwires or Molex™ connector.
7. Restore power, and check out operation.

**WIRING**

NOTE: Each 3-wire (SPDT) actuator must have individual SPDT controller. Use series 40 or 80 for single controller to control multiple valves. VC21.14 and VC81.14 actuators must be used with separately-powered (hardwired) electronic controllers. Their sustained current draw is too low for power stealing (parasitic power) thermostats or series anticipators of electromechanical thermostats.

Figures 4A, 4B, 5A, 5B show wiring connections. Port "A" open and closed denote valve open and closed positions respectively. On auxiliary switch models, terminal 4 (grey wire) contact makes at the end of the Port A opening stroke. On Molex™ connector models, valve & auxiliary switch voltage must be the same to meet approval requirement. For mixed line voltage and 24 Vac (Safety Extra Low Voltage) application, the cable version is recommended.

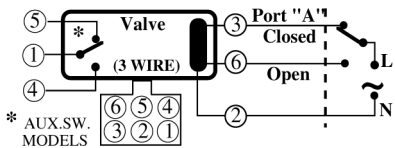

**Fig. 4. Wire configuration for MOLEX™ models for SPDT controller. (Series 20 & 60).**

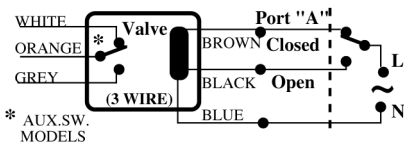

**Fig. 5. Wiring color code for cable models for SPDT controller. (Series 20 & 60)**

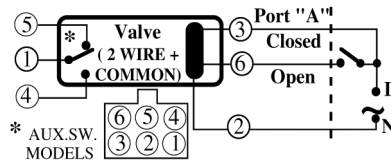

**Fig. 6. Wire configuration for MOLEX™ models for SPST controller. (Series 40 & 80)**

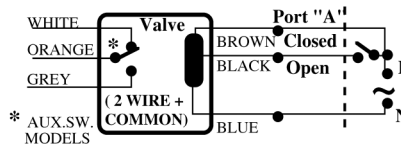

**Fig. 7. Wiring color code for cable models for SPST controller. (Series 40 & 80)**

**Table 2.**

Actuator Type	Connection		Valve Movement
	Cable model	Molex™ model	
3-WIRE (for SPDT controller)	Blue & Brown energised Black de-energised	Pin# 2 & 3 energised Pin# 6 de-energised	A port Closes
	Blue & black energised Brown de-energised	Pin# 2 & 6 energised Pin# 3 de-energised	B port Closes
2 + COM. (for SPST controller)	Blue & Brown energised Brown & Black open	Pin# 2 & 3 energised Pin# 3 & 6 open	A port Closes
	Blue & Brown energised Brown & Black closed	Pin# 2 & 3 energised Pin# 3 & 6 closed	B port Closes

**OPERATION**

WHEN USED WITH SPDT (3-WIRE) CONTROLLER (Fig. 6): On a call for heat, the NO thermostat contacts close, the valve opens port "A" and closes port "B". When the valve reaches port "A" fully open position, the cam actuated SW1 closes and SW2 opens. When the need for heat is satisfied the NC thermostat contacts close, energizing the valve through SW1 to close port "A". When port "A" is fully closed, the cam actuated SW2 closes and SW1 opens anticipating the next call for heat cycle. In a power failure the valve will stay at whatever position it was in when the power was interrupted. When power is restored, the valve will respond to the controller demand.

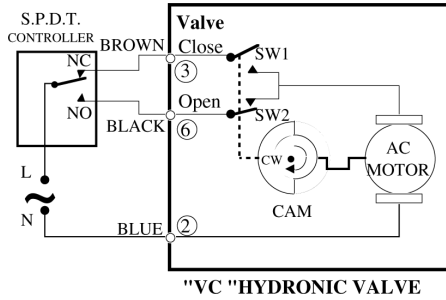

**Fig. 8. Actuator wiring for SPDT controller**

WHEN USED WITH SPST CONTROLLER (Fig. 7):  
 On a call for heat, the thermostat contacts close. RLY1 is energized making the NO contacts in SW3, the valve opens port "A" and closes port "B". When the port "A" reaches the fully open position the cam operated SW1 closes and SW2 opens. When need for heat is satisfied, the thermostat contacts open. RLY1 is de-energized making the NC contacts in SW3 and port "A" is driven closed through SW1 and the NC contacts of SW3. When the port "A" fully closed position is reached, the cam operated SW2 closes and SW1 opens anticipating the next call for heat cycle.

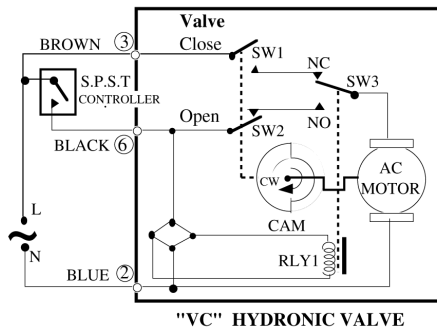

**Fig. 9. Actuator wiring for SPST controller**

**CHECKOUT**

1. Raise the set point of the thermostat above room temperature to initiate a call for heat. Red valve position lever should move downward to the open position.
2. Observe all control devices - Port A should open, port B should close and the auxiliary switch (if present) should operate and make at the end of the opening stroke activating the auxiliary equipment.
3. Lower the set point of the zone thermostat below room temperature.
4. Observe the control devices. Port A should close and all auxiliary equipment should stop.

**SERVICE**

This valve should be serviced by a trained, experienced service technician.

1. If the valve is leaking, drain system OR isolate valve from the system. Do not remove body from plumbing.
2. Check to see if the cartridge needs to be replaced.
3. If the motor or other internal parts of the actuator is damaged, replace the entire actuator assembly.

NOTE: Resideo hydronic valves are designed and tested for silent operation in properly designed and installed systems. However, water noises may occur as a result of excessive water velocity. Piping noises may occur in high temperature (over 212°F [100°C]) systems with insufficient water pressure.

For trouble-free operation of the product, good installation practice must include initial system flushing, chemical water treatment, and the use of a 50 micron (preferably 5 micron) 10% side stream system filter(s). Remove all filter(s) before flushing. Limit flow through the filter to 5~10% of total system flow to prevent 'starving' the system. Ensure filter cartridge is changed frequently enough to prevent clogging.

3-WAY BALANCED HYDRONIC VALVES





**WEEE Directive 2012/19/EU Waste of Electrical and Electronic Equipment**

Do not dispose of this device and contained batteries with general household waste. For proper treatment, recovery and recycling, please take the device and contained batteries to designated collection points. Disposing of this device and contained batteries correctly will help save valuable resources and prevent any potential negative effects on human health and the environment, which could otherwise arise from inappropriate waste handling.



Manufacturer for European Region:  
Pittway Sarl, Z.A. La Piece 6,  
1180 Rolle, Switzerland  
Country of origin: Hungary  
95C-10647-09 SA Rev. 08-23

Manufacturer for North and South America Region:  
Resideo Technologies, Inc.  
1985 Douglas Drive North, Golden Valley, MN 55422  
1-800-468-1502



Points de collecte sur [www.quefairedemesdechets.fr](http://www.quefairedemesdechets.fr)  
Privilégiez la réparation ou le don de votre appareil !

