

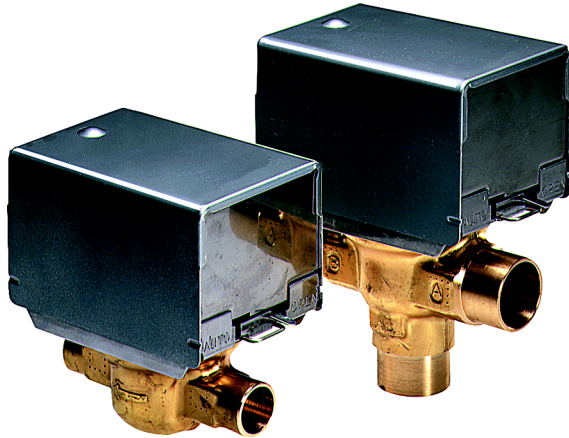

Series-3000 VU52, VU53, VU54; VU442, VU443, VU444; VU842, VU843, VU844 Fan Coil Valves and Actuators

PRODUCT DATA



VU Fan Coil Actuator and Valves

APPLICATION

The VU442/VU842, VU443/VU843, and VU444/VU844 Fan Coil Valve Actuators are used in conjunction with the VU52, VU53 and VU54 valves for 2-position control of low pressure steam, or hot and chilled water with up to 50% glycol in commercial HVAC equipment such as fan coil units, terminal reheat coils and convectors. These valves are humidity resistant and are suitable for use in condensing, noncorrosive environments.

IMPORTANT

These valves are not for use in open systems or for control of potable water.

Contents

Application	1
Features	1
Specifications	2
Installation	5
Wiring	7
Operation	7
Checkout	8
Service	8

FEATURES

- Compact construction for easy installation.
- Fits under the cover of most baseboard convectors with actuator fitted.

ACTUATOR

- One-button, quick actuator release.
- Secure 3-point, metal latch to valve body.
- Spring return operation.
- Stainless steel case and aluminum cover.
- Line or low voltage, rust-resistant motors.
- Slotted conduit hole for faster wiring.
- Connecting leads available up to 8 feet (2.4 m) long.
- Manual opener for valve operation with automatic return when power is restored.
- Actuator may be reinstalled or serviced without draining the system or disassembling the valve.
- VU442, VU842 actuators fit 2-way VU52 valve bodies.
- VU443, VU843 actuators fit 2-way VU53 valve bodies.
- VU444, VU844 actuators fit 3-way VU54 valve bodies.

VALVE

- VU52, VU53 provide 2-way, straight-through control of water, or low pressure steam with Class F motors.
- VU54 provides 3-way mixing or diverting control of water.
- 300 psi (2,000 kPa, PN20) operating pressure rating.
- 15 psi low pressure steam rating for 2-way products
- Patented ball plug provides long service life, soft close off.
- Triple stem O-ring seal.
- Quick opening flow curve for rapid response.
- Choice of sweat, f-NPT, or inverted flare connections.



SPECIFICATIONS

Table 1. Series-3000 VU fan-coil valve actuator models

Model	Type		Use With	Electrical Ratings				Timing, sec.		Temperature Rating	Auxiliary Switch	Comments	
				Voltage	Current	Power	Connections	Open	Close				
VU442	2-way	Normally Open	VU52	120V~60Hz ^a	0.07 A	5W @ 60Hz;	6 in (15 mm) motor leads standard.	4 s	12 s	Class F	SPST, 1A or 5A inductive available ^b	Nickel-plated motor	
VU842A				24V~50/60Hz									0.32A
VU443A	2-way	Normally Closed	VU53	120V~60Hz ^a	0.07 A	---	18 in (45 mm) leadwires available ^b	12 s	4 s	Class A		--	
VU843A				24V~50/60Hz									0.32A
VU843B													
VU444A	3-way	Mixing / Diverting	VU54	120V~60Hz ^a	0.07 A			4 s	Class F			Nickel-plated motor available	
VU844A				24V~50/60Hz									0.32A

^a 230V~50Hz/240V~60Hz and 277V~60Hz available on request, Class A, zinc-plated motor only. Contact factory.

^b Contact factory for availability

Maximum Ambient @ Fluid Temperature Rating:

High close-off actuators (with class A motor):

104°F(40°C) ambient @ 200°F(94°C) fluid.

Standard actuators (with class F motor)

130°F(54 C) ambient @ 249°F(120 C) fluid or low pressure steam without superheat.

Minimum Ambient Temperature:

34°F(1°C)

Shipping and Storage Temperature:

-40°F to 150°F (-40 to +65 C)

Atmosphere:

Non-corrosive, non explosive.

Noise Rating:

Low Noise: less than 40 dBA.

Materials:

Case: 316 stainless steel.

Cover: aluminum.

Sector gear: stamped brass

Motor: zinc-plated; nickel-plating available for high humidity chilled water applications.

Dimensions:

See Fig. 1.

Table 2. Series-3000 VU fan-coil valve models.

Model	Type	Model Suffix ^b			Pipe Size		Flow Capacity,		Maximum Differential Pressure, ^a			
		Inverted Flare ^c	Female NPT	Sweat	in.	S.I.	in Cv	(kvs)	in psi	(kPa)		
VU52 ...	2-way Normally Open	N/A	...N	...S	1/2	DN15	1.0	(0.9)	50	(345)		
		...F					2.4	(2.1)			30	(207)
		N/A					3.5	(3.0)			20	(138)
and VU53 ...	2-way Normally Closed	N/A			3/4	DN20	5.0	(4.3)	14	(97)		
							8.0	(6.9)			10	(69)
							1	DN25				
VU54 ...	3-way Mixing/Di verting	N/A	...N	...S	1/2	DN15	1.5	(1.3)	28	(193)		
		...F					3.0	(2.6)				
		N/A					4.0	(3.4)			20	(138)
							3/4	DN20			7.0	(6.0)
			1	DN25								

^a Maximum pressure drop across open valve seat, or between coil and bypass for water service

^b For example: 3-way valve with NPT pipe fittings is VU54N...

^c 5/8-in. flare end and 3.5 Cv only. Inverted flare nut and tailpiece sold separately.

Max. Fluid Temperature:
249°F (120 C)

Min. Fluid Temperature:
34°F(1°C) for all models.

Maximum soldering temperature:
500°F (260 C)
Consult factory before brazing

Max. Operating Pressure Rating:
Water: 300 psig (2000 kPa), PN20.
Steam: 15 psig (No superheat allowed; 2-way bodies only)

Accessories:
272708A 1/2 in. inverted flare to 1/2 in. sweat adapter
272708B 1/2 in. inverted flare to 3/4 in. sweat adapter

Close-off Pressure Ratings: See Table 3

Table 3. Series-3000 VU fan-coil valve static close-off pressure ratings with water.

Valve Model	Flow Capacity		Close-Off Pressure Rating by Actuator, in psi (kPa) ^a								
	Cv	(kvs)	VU442/842A		VU443/843A		VU843B		VU444/844A		
			N.O.	(kPa)	N.C.	(kPa)	N.C. H.C.O	(kPa)	Mixing	(kPa)	Diverting ^b
VU52	1.0	(0.9)	60	(41)							
	2.4	(2.1)	60	(41)							
	3.5	(3.0)	40	(28)							
	5.0	(4.3)	28	(19)							
	8.0	(6.9)	20	(14)							
VU53	1.0	(0.9)			50	(34)	60	(41)			
	2.3	(2.0)			30	(21)	60	(41)			
	3.5	(3.0)			20	(14)	40	(28)			
	5.0	(4.3)			14	(10)	28	(19)			
	8.0	(6.9)			10	(7)	20	(14)			
VU53	1.5	(1.3)							28	(19)	Not measurable: Water pressure forces plug into seat ^b
	3.0	(2.6)							28	(19)	
	4.0	(3.4)							20	(14)	
	7.0	(6.0)							12	(8)	

^a Do not exceed Maximum Differential Pressure to ensure motor and spring open and close valve. Rating is pressure drop across valve with valve closed, not head pressure of pump.

^b Do not exceed coil differential pressure to prevent water hammer and ensure motor and spring open and close valve.

Flow Characteristics:
Quick opening for on-off application. Flow is approximately 50% at 20% open.

Materials:
Valve body: forged brass.
Drive shaft stem: "Double D" 316 stainless steel.
Ball plug: EPDM rubber.
O-ring seals: EPDM rubber.

Service Medium:
Suitable for hot and chilled water with up to 50% glycol.
2-way valves suitable for low pressure steam, 15 psi, 249°F (120 C) maximum.

Approvals:
CSA C/US Certified, LR1322.

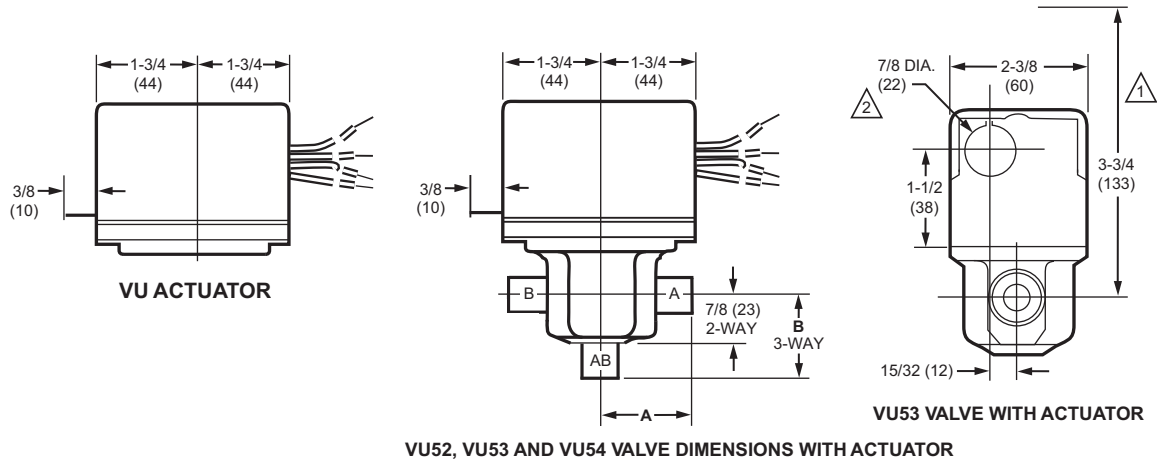

VU52, VU53 AND VU54 VALVE DIMENSIONS WITH ACTUATOR

VALVE BODY SIZE	A	B
1/2 IN. SWEAT	1-5/16 (33)	1-5/16 (33)
3/4 IN. SWEAT	1-3/8 (35)	1-11/16 (43)
1 IN. SWEAT	1-11/16 (43)	1-11/16 (43)
1/2 IN. F-NPT	1-3/8 (35)	1-5/16 (33)
3/4 IN. F-NPT	1-11/16 (43)	1-7/16 (37)
1 IN. F-NPT	1-11/16 (43)	1-7/16 (37)
1/2 IN. INVERTED FLARE	1-3/8 (25)	1-5/16 (33)

- △1 HEIGHT NEEDED TO REMOVE ACTUATOR OR COVER.
- △2 OPENING FOR 1/2 IN. CONDUIT ON OPPOSITE SITE OF MANUAL LEVER FOR ALL MODELS.

M32076

Fig. 1. Mounting Dimensions in in. (mm).

CAUTION

Equipment Damage Hazard

- Foreign particles like sand (quartz), rust, and metal chips can damage the ball plugs.
- For trouble-free operation of the product, good installation practice must include initial system flushing, and chemical water treatment. Clean the lines upstream of particles larger than 1/16 inch diameter (welding slag, pipe scale, sand and other suspended particulate). Remove all Y-strainer filters before flushing.
- Anti-freeze solutions that can be used, with minimum 50% water dilution, are diethylene glycol, ethylene glycol, and propylene glycol.
- Do not use boiler additives, solder flux and wetted materials which are petroleum based or contain mineral oil, hydrocarbons, or ethylene glycol acetate. These chemicals can cause O-rings and ball plug to swell and affect product performance.
- If installing these valves in an addition to, or retrofitting an existing building, do not assume that the fluid in the existing piping meets these criteria.
- When installing threaded fittings and pipes, if tape is unavailable use minimum possible amount of pipe dope. Excessive dope may be forced into valve seat and interfere with valve operation when pipe is assembled to body.

IMPORTANT

Hold valve by wrench flats **ONLY** when tightening pipe fittings. Do **NOT** hold the valve body with the pipe wrench: product damage may result.

1. Proceed with installation once the system specifics (expansion/contraction of the system and its medium as well as operating pressures) are within tolerances.
2. Eliminate air from system.
3. Three-way valves may be installed for mixing or diverting control.
4. Two-way valves are marked to show flow direction.

IMPORTANT

Flow arrows must point in the direction of the flow for proper operation and to prevent water hammer.

How to Find Valve Pressure Drop

Valve pressure drop is determined by the formula:

$$\Delta P = (\text{gpm}/C_v)^2 \times \rho$$

where ρ is the density of the glycol solution, and typically ranges between 0.95 and 1.05.

The pressure drop in psi, or feet of water can be determined from Fig. 2 as follows:

1. Calculate the flow rate to cool and dehumidify.
2. Determine the C_v rating of the valve.
3. Select the graph corresponding to the C_v rating of the valve.
4. Determine the pressure drop across the valve using the following procedures for calculating pressure drop:

- (1) Locate the flow rate at the bottom of the graph.
- (2) Draw a line up from the flow rate to the intersection of the curve.
- (3) Draw a line from the intersection to the left edge of the graph to determine the pressure drop in psi, or to the right edge to determine the pressure drop in feet of Head. (Pressure drop in feet of Head = psi X 2.2.)

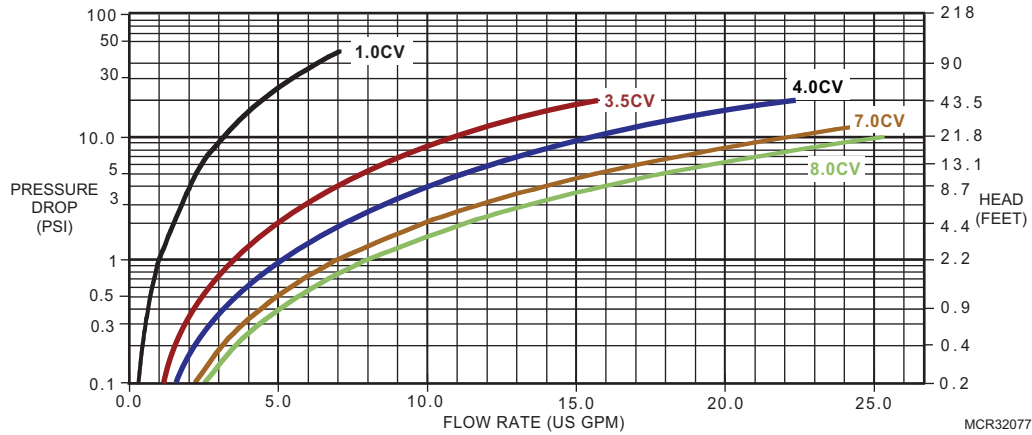

Fig. 2. Flow characteristics of VU52, VU53, VU54 valves, ANSI units.

INSTALLATION

When Installing this Product...

1. Read these instructions carefully. Failure to follow them could damage the product or cause a hazardous condition.
2. Check the ratings given in the instructions and on the product to make sure the product is suitable for your application.
3. Installer must be a trained, experienced, licensed service technician.
4. After installation is complete, check out product operation as provided in these instructions.



CAUTION

Disconnect power supply before connecting wiring to prevent electrical shock or equipment damage.

On 24V systems, never jumper the valve coil terminals even temporarily. This can burn out the heat anticipator in the thermostat.

Wear safety glasses to protect eyes from injury when removing or installing the large spring clip that holds the actuator mounting plate to the valve body.

Use proper snap ring pliers to remove or install spring clip.



WARNING

Ensure that spring clip is properly seated before repressurizing valve.

Mounting

The valve can be mounted in any position on a vertical line.

See Fig. 3 If the valve is mounted horizontally; the actuator must be even with or above the center line of the piping.

Make sure to leave enough room above the actuator to remove the cover or actuator for servicing.

IMPORTANT

Make sure that the flow through the valve is in the direction indicated by the arrow on the valve body. 2-way valves must close against the flow to prevent water hammer.

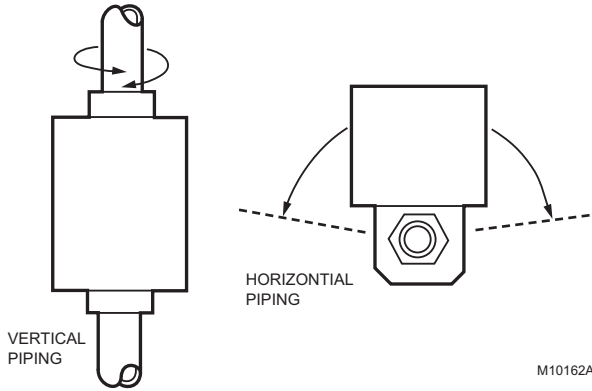

Fig. 3. Mounting positions.

On 3-way valves, the three fittings or ports are labeled on the bottom of the valve body casting. Port AB is the inlet port and is open at all times. Port A is closed and port B is open when the valve is de-energized. Refer to the equipment manufacturer instructions to determine which port (A or B) should be connected to the coil bypass. 3-way valves may be installed as mixing valves after the coil (recommended) or as diverting valves before the coil.

Sweat Copper Models

1. Use new, properly reamed pipe, free from dents or corrosion.
2. Place the valve on the pipe. Rotate valve stem so that the shaft flats point at the notch in the side of the body (90° to flow directions.) See Fig. 4. This protects the plug inside the valve by removing it from the seat.
3. Sweat the joints, keeping the outer surface free from solder. DO NOT BRAZE sweat bodies without appropriate tools because the high temperature can damage main body O-ring and cause leaks.

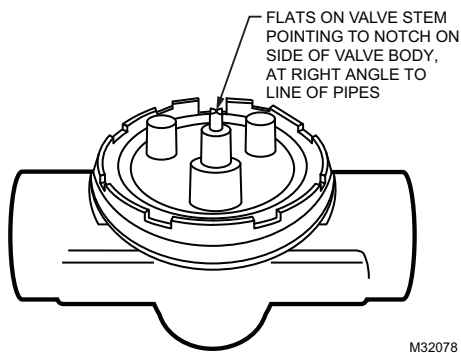

Fig. 4. Slot position.

To Install & Remove Actuator

INSTALLING ACTUATOR ON VU-SERIES VALVE BODY ASSEMBLY (See Fig. 5):

1. Orient flats on stem of VU-series valve body at 90° to water flow (toward notch in side of body). See Fig. 5. This lifts the ball off seat, prevents damage to the ball seat while soldering, and makes actuator attachment easier.
2. Install valve body into pipe.
3. Wiring connections may be made either before or after actuator installed on valve body.
4. Place manual operating lever on the actuator in the MAN. OPEN position.
5. Line up motor coupling to slot in shaft of body and fit the head onto the valve body, ensuring that the shaft seats correctly. (See Fig. 5.)
6. Snap actuator onto body by pressing down.
7. Make wiring connections. Refer to wiring section for proper instructions.

Inspect the actuator installation and the valve body to ensure that all connections and adjustments have been correctly made. Adjust the thermostat or controller connected to the valve so that the valve runs through its cycle. Make sure the valve runs smoothly and positively from closed to open to closed again.

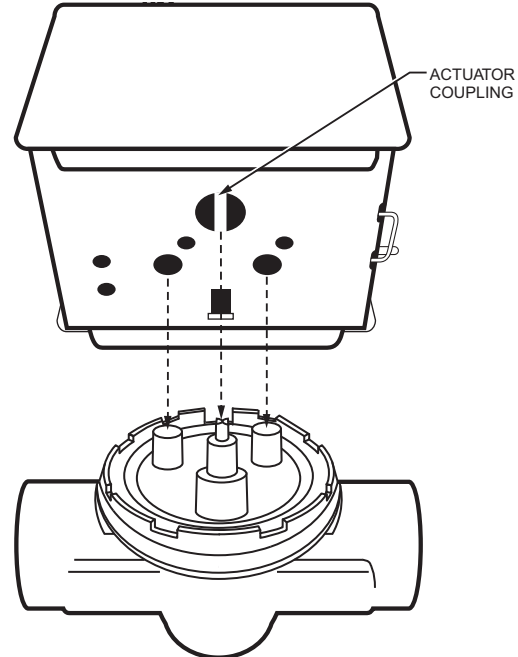
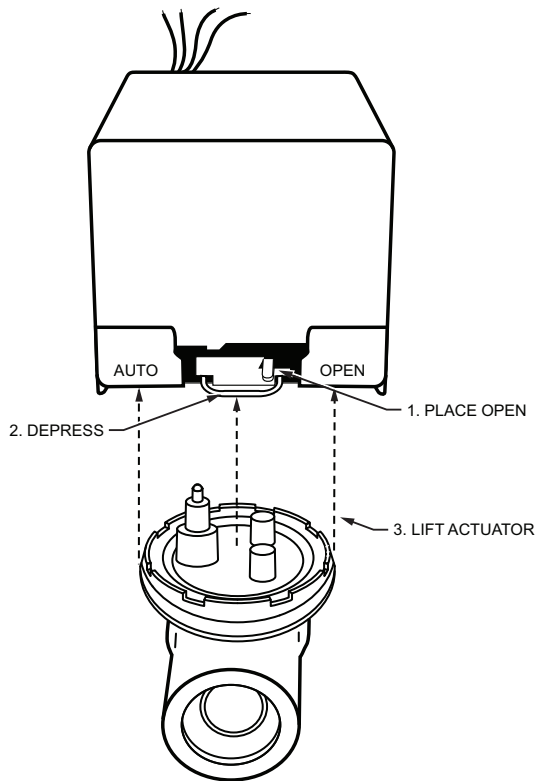

Fig. 5. Installing new actuator.

REMOVING ACTUATOR FROM THE VU-SERIES VALVE BODY ASSEMBLY (See Fig. 6)



IMPORTANT
USE MANUAL LEVER TO OPEN ACTUATOR BEFORE ATTEMPTING TO MOUNT ON VALVE. M32081

Fig. 6. Removing actuator from valve.

NOTE: It is not necessary to drain the system if the valve body assembly remains in the pipeline.

1. Switch power supplies OFF. Disconnect electrical leads, carefully noting the position and color of each lead.
2. Place the manual operating lever in the MAN. OPEN position. See Fig. 6.
3. Remove actuator by depressing locking button and lifting straight up.

WIRING

Disconnect the power supply before connecting wiring to prevent electrical shock or equipment damage. All wiring must comply with local codes and ordinances. See Fig. 7 and 8 for typical hookups.

To Attach Flexible Conduit

1. Strip cable jacket.
2. Fit conduit strain relief onto cable.
3. Slide strain relief nut over wires.

4. Connect cable and actuator wires.
5. Slide cable wires down through slot in the wiring hole, so that the strain relief nut is inside the actuator housing.
6. Secure nut onto strain relief.
7. Install actuator cover.

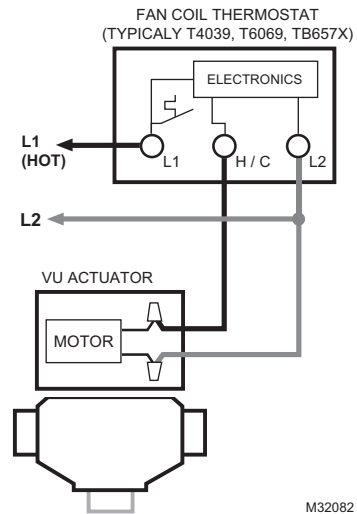

Fig. 7. Typical wiring for VU40-series actuator.

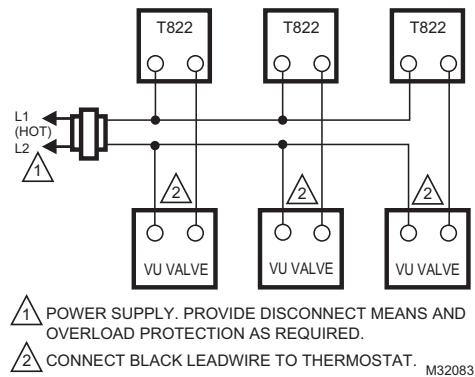

Fig. 8. SPST Thermostat, VU80-series actuator hookup.

OPERATION

CAUTION
ON 24V SYSTEMS, NEVER JUMPER THE VALVE COIL TERMINALS EVEN TEMPORARILY. THIS CAN BURN OUT THE HEAT ANTICIPATOR IN THE THERMOSTAT.

Automatic Operation

On a call for heat or cool by the fan coil thermostat, the valve motor operates, opening the valve. When the call ends, the valve closes by integral spring return.

Manual Operation

The 2-way normally closed and 3-way motorized valve actuators can be opened manually, without power, by lifting the manual opening lever over the stop and pushing slowly and firmly to the MAN. OPEN position. The stop permits the valve to be locked in the open position. The valve returns to automatic position when it is energized.

Normally Closed Models

With the manual opener set to AUTO and the actuator energized, the A port is opened as shown in the powered diagrams in Fig. 9 and 10. When the actuator is de-energized, a spring-return mechanism drives the valve to the port A closed position as shown in the unpowered diagrams in Fig. 9 and 10. The valve can also be opened with no electrical power by moving the manual opening lever over the stop and pushing slowly and firmly to the MAN. OPEN position. The stop permits the valve to be locked in an open position. The valve returns to the automatic position.

3-way valves may be installed as Normally Closed or Normally Open by exchanging the orientation of the A and B ports.

Normally Open 2-way Models

With the manual opener set to AUTO and the actuator energized, the A port is closed as shown in the powered diagrams in Fig. 9. When the actuator is de-energized, a spring-return mechanism drives the valve off the port A as shown in the “N.O. DE-ENERGIZED” position in Fig. 9 and 10. The manual opener is only used for installing or removing the actuator from the body.

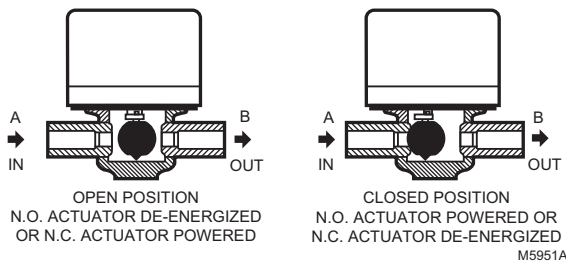

Fig. 9. VU842/442, VU843/443 Actuator operation for 2-way valve.

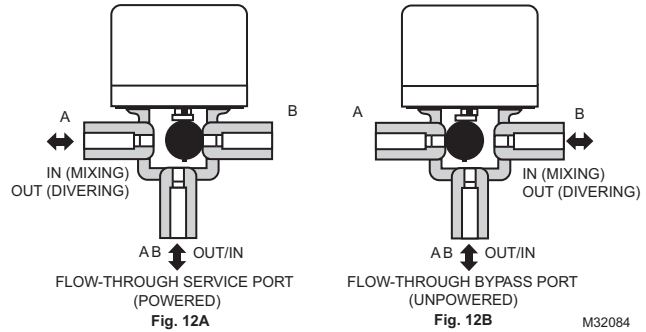

Fig. 10. VU844/444 Actuator operation for 3-way valve.

CHECKOUT

Set to heating mode

1. Raise the setpoint on the zone thermostat above the room temperature to initiate a call for heat.
2. Observe all control devices—the valve should open.
3. Lower the setpoint on the zone thermostat below the room temperature.
4. Observe the control devices. The valve should close.

Set to cooling mode

1. Lower the setpoint on the zone thermostat below the room temperature to initiate a call for cooling.
2. Observe all control devices—the valve should open.
3. Raise the setpoint on the zone thermostat above the room temperature.
4. Observe the control devices. The valve should close.

SERVICE

This valve should be serviced by a trained, experienced service technician.

1. If the valve is leaking, drain the system and check to see if the O-ring needs replacing.
2. If the gear train is damaged, replace the entire actuator. See the Installation section. If the motor is burned out, replace the motor.

NOTE: The fan coil valves are designed and tested for silent operation in properly designed and installed systems; however, water noises can occur as a result of excessive water velocity or piping noises can occur in high temperature (higher than 212°F (100°C)) systems with insufficient water pressure. Valves are designed to be cycled regularly. Product life may be shortened if energized continuously for extended periods of time.



www.resideo.com

Resideo Technologies, Inc.
1985 Douglas Drive North, Golden Valley, MN 55422
1-800-468-1502
95C-10885-01 M.S. Rev. 08-21 | Printed in United States