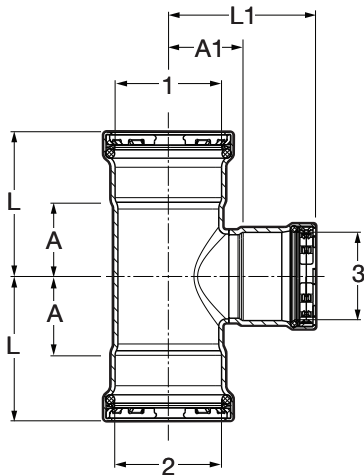
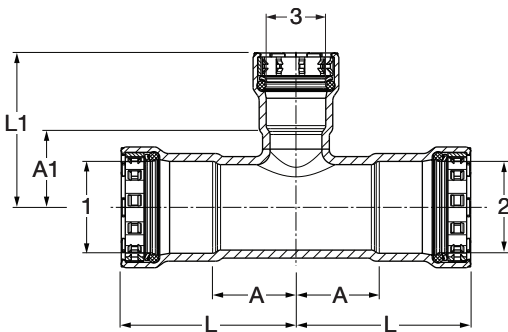

Viega MegaPress Tee P x P x P - Models 4818XL / 6618XL

Part No.	FKM	HNBR	Size (in)			A (in)	A1 (in)	L (in)	L1 (in)
			1	2	3				
NA	28910		2½	2½	1	1.35	2.04	3.15	3.38
NA	28905		2½	2½	1¼	1.72	2.06	3.52	3.87
26575	28675		2½	2½	1½	1.72	2.08	3.52	3.95
26580	28680		2½	2½	2	2.16	2.05	3.96	4.04
26560	28660		2½	2½	2½	2.16	2.26	3.96	4.06
26595	28695		3	3	1¼	1.70	2.31	4.04	4.13
26590	28690		3	3	1½	1.80	2.33	4.13	4.20
26585	28685		3	3	2	2.11	2.30	4.41	4.29
26600	28700		3	3	2½	2.32	2.51	4.63	4.31
26565	28665		3	3	3	2.55	2.52	4.88	4.82
26605	28705		4	4	1½	1.86	2.90	5.04	4.77
26610	28710		4	4	2	2.18	2.87	5.35	4.86
26615	28715		4	4	2½	2.40	3.08	5.55	4.88
26620	28720		4	4	3	2.66	3.13	5.81	5.43
26570	28670		4	4	4	3.22	3.08	6.40	6.26

MegaPress Reducing Tee, Carbon Steel, P x P x P - Models 4818 / 5918 / 6618

EPDM	Part No.		Size (in)			A (in)	A1 (in)	L (in)	L1 (in)
	FKM	HNBR	1	2	3				
25330	84410	25331	¾	¾	½	1.11	1.07	2.26	2.14
25335	84415	25336	1	1	½	1.23	1.20	2.57	2.28
25340	84420	25341	1	1	¾	1.23	1.24	2.57	2.40
25510	84380	25491	1¼	1¼	½	1.41	1.35	3.23	2.42
25515	84385	25496	1¼	1¼	¾	1.41	1.39	3.23	2.55
25350	84390	25351	1¼	1¼	1	1.41	1.38	3.23	2.73
25360	84425	25361	1½	1½	½	1.57	1.44	3.44	2.51
25365	84430	25366	1½	1½	¾	1.57	1.48	3.44	2.64
25370	84435	25371	1½	1½	1	1.57	1.48	3.44	2.83
25375	84440	25376	1½	1½	1¼	1.57	1.50	3.44	3.32
25380	84445	25381	2	2	½	1.81	1.74	3.80	2.81
25385	84450	25386	2	2	¾	1.81	1.80	3.80	2.95
25390	84455	25391	2	2	1	1.81	1.75	3.80	3.10
25395	84460	25396	2	2	1¼	1.81	1.78	3.80	3.60
25400	84465	25401	2	2	1½	1.81	1.84	3.80	3.71