

SUPERSEDES: August 15, 2005

EFFECTIVE: June 1, 2009

Plant ID# 001-1026

WARNING: Do not use iSeries products for potable water tempering or in any application where scalding can occur as a result of exposure to the tempered water.

The iSeries-S is a microprocessor-based valve designed to provide a setpoint (fixed) temperature to a heating system by modulating the position of an iSeries Mixing Valve. With the addition of a boiler sensor, the iSeries-S can provide boiler protection in order to prevent boiler flue gas condensation.

2-Way / 3-Way / 4-Way Mixing

An iSeries Mixing Valve may be used to mix the hot boiler water temperature with the cooler return water temperature from the system loop. The position of the iSeries Mixing Valve is modulated in order to inject different rates of hot water into the cooler system return water. This allows for virtually any water temperature to be supplied to the heating system. When deciding between using a 2-way, 3-way or 4-way valve, maximum flow rates must be considered. See the charts on pages 2 and 3 before selecting style of valve / piping.

Most boilers cannot operate at low temperatures, therefore the iSeries-S can be modulated back in order to prevent the boiler from operating at cold temperatures by installing the boiler sensor.

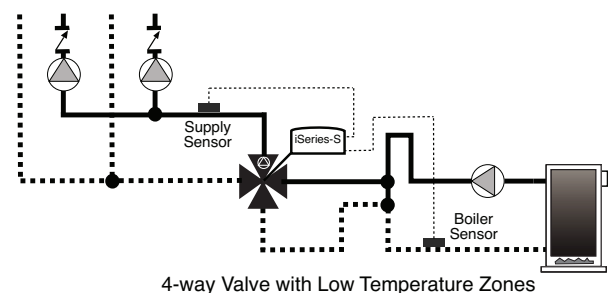
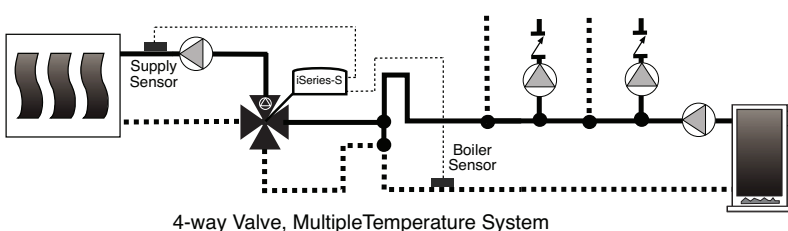
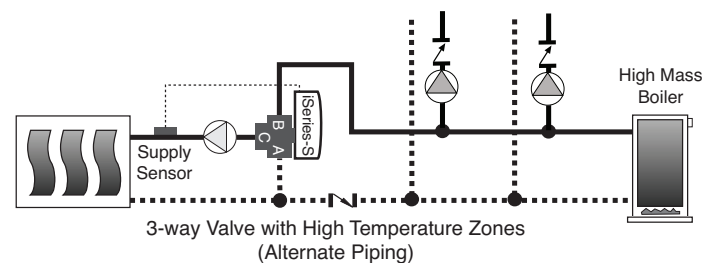
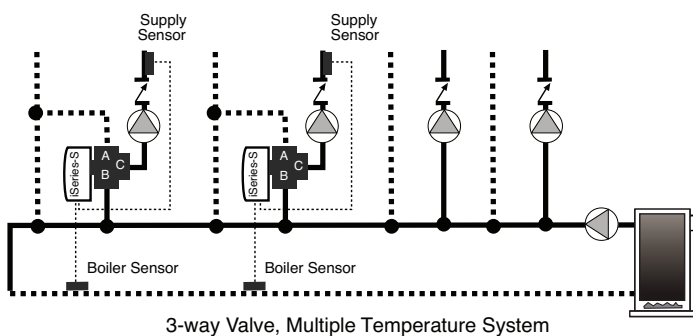
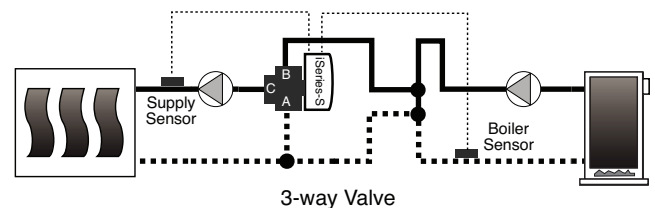
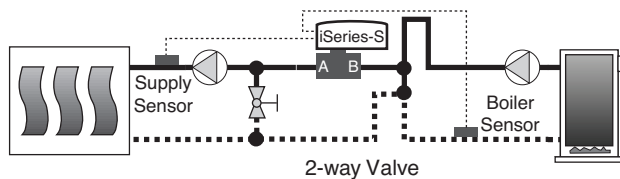

Design

When using an iSeries-S Mixing Valve, the following piping requirements must be considered for proper operation.

1. In order to hydraulically isolate the boiler loop from the injection or system loop primary/secondary piping must be used. There must be no more than 4 pipe diameters between the tees in the boiler loop (Note 1).
2. There must be at least 6 pipe diameters of straight pipe on either side of the tees (Note 2) in order to prevent the momentum of water in the boiler loop from pushing flow through the injection loop.
3. There should be a minimum of 1 foot drop on the return pipe of the injection loop, in order to create a thermal trap (Note 3) and prevent unwanted heat transfer.
4. When using a 2-way iSeries-S Mixing Valve, a balancing valve must be located between the tees in the system loop, in order to provide a pressure drop to induce flow through the mixing valve.

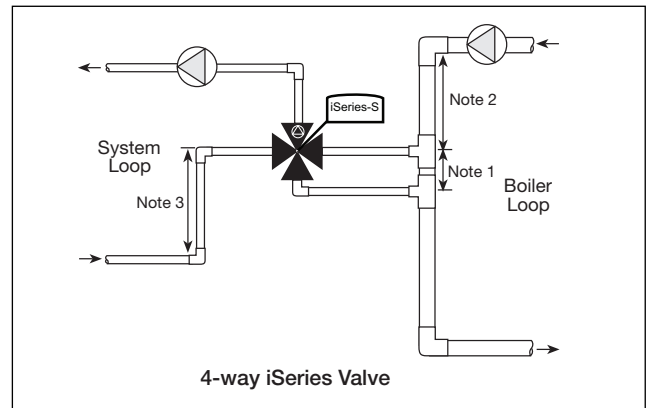
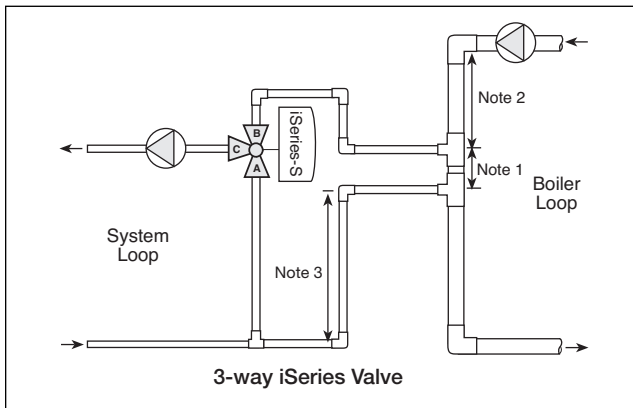
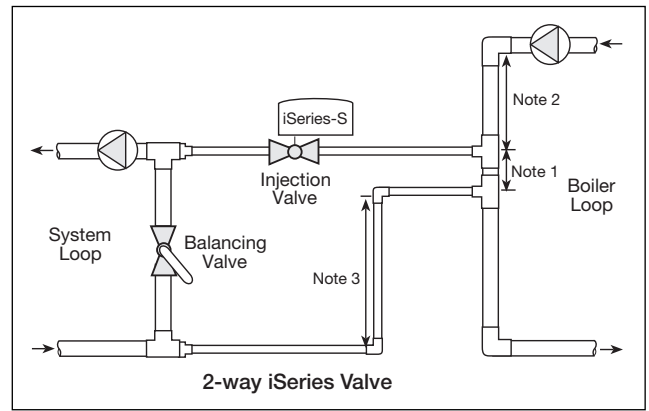

2-Way iSeries Mixing Valve Selection

In order to properly size the 2-way iSeries Mixing Valve, follow the design procedure below:

- 1) Determine the design radiant heating load.
- 2) Determine the design boiler supply temperature.
- 3) Determine the radiant system return temperature which is based on the design temperature drop across the radiant system.
- 4) Determine the design injection flow rate using the following equation:

$$\text{Eq. 1: Design Injection Flow Rate (US GPM)} = \frac{\text{Design Radiant Heating Load (BTU/hr)}}{500 \times (\text{Boiler Supply} - \text{Radiant System Return})}$$

- 5) From the 2-way Cv chart below, select the valve size with the closest Cv value to the design injection flow rate calculated in step 4.

iSeries: 2-way Cv	
Size	Cv
1/2"	4.9
3/4"	10.3
1"	8.9

3-Way / 4-Way iSeries Mixing Valve Selection

Select the 3-way or 4-way iSeries Mixing Valve based on the Pressure Drop chart below.

iSeries 3-way Valve Pressure Drop												
Flow GPM	1/2" Sweat & Threaded C _v = 1.5		1/2" Union C _v = 3.5		3/4" Sweat & Threaded C _v = 3.5		3/4" Union C _v = 4.5		1" Sweat & Threaded C _v = 4		1" Union C _v = 4.5	
	PSI	Ft. Head	PSI	Ft. Head	PSI	Ft. Head	PSI	Ft. Head	PSI	Ft. Head	PSI	Ft. Head
1/2	0.11	0.26	0.02	0.05	0.02	0.05	0.01	0.03	0.02	0.04	0.01	0.03
1	0.44	1.03	0.08	0.19	0.08	0.19	0.05	0.11	0.06	0.14	0.05	0.11
2	1.78	4.10	0.33	0.75	0.33	0.75	0.20	0.46	0.25	0.58	0.20	0.46
4	—	—	1.31	3.01	1.31	3.01	0.79	1.82	1.00	2.31	0.79	1.82
6	—	—	2.94	6.78	2.94	6.78	1.78	4.10	2.25	5.19	1.78	4.10
8	—	—	5.22	12.05	5.22	12.05	3.16	7.29	4.00	9.23	3.16	7.29
10	—	—	—	—	—	—	4.94	11.39	6.25	14.42	4.94	11.39
12	—	—	—	—	—	—	7.11	16.41	—	—	7.11	16.41

iSeries 4-way Valve Pressure Drop						
Flow GPM	3/4" C _v = 7.0		1" C _v = 9.3		1 1/4" C _v = 17.5	
	PSI	Ft. Head	PSI	Ft. Head	PSI	Ft. Head
1/2	0.01	0.01	0.00	0.01	0.00	0.00
1	0.02	0.05	0.01	0.03	0.00	0.01
2	0.08	0.19	0.05	0.11	0.01	0.03
4	0.33	0.75	0.18	0.43	0.05	0.12
6	0.73	1.69	0.42	0.96	0.12	0.27
8	1.31	3.01	0.74	1.71	0.21	0.48
10	2.04	4.71	1.16	2.67	0.33	0.75
12	2.94	6.79	1.66	3.84	0.47	1.08
14	4.00	9.24	2.28	5.27	0.64	1.48
16	—	—	2.96	6.84	0.84	1.93
18	—	—	3.76	8.70	1.06	2.44
20	—	—	—	—	2.30	5.31

Sequence of Operation

Power Up and Heat Request

Whenever the iSeries-S is powered up, the LED turns green and the control starts operation. The power to the iSeries-S may be switched through an end switch (e.g. Taco ZVC/SR style zone control), a thermostat for intermittent operation, or the power source may be connected directly to the iSeries-S for continuous operation.

Setpoint

The iSeries-S operates the valve to maintain a fixed setpoint. The setpoint temperature is set using the Setpoint dial located on the top of the actuator. The setpoint range available is from 80°F to 180°F.

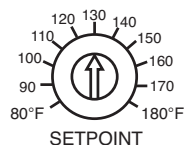

Boiler Protection

An optional boiler return sensor (Taco part #9300-2044RP) can be installed to provide boiler protection. When the boiler return temperature is below 135°F, the green LED flashes rapidly (reduced output) and the iSeries-S modulates towards the closed position in order to allow the boiler temperature to recover.

Setback

The iSeries-S has a setback function used to lower the setpoint target. The setpoint target is lowered by 15°F whenever there is a contact closure across the SETBACK and SENSOR COMMON terminals.

Valve Installation

WARNING: Operator must be removed from the valve body before soldering. Ball valve must be in the full open position before soldering. Valve is shipped in the full closed position.

1. Valve body may be installed in any position, in any orientation (see Figure A). 3-way actuator's power connections must be over the supply port to ensure proper flow direction (see Figure A).
2. Before mounting body, refer to Figure B and Dimensions Section for clearances.
3. Use of a lead or tin based solder with a melting point below 600°F is recommended. Do not overheat. Make sure the ball valve is in the **FULL OPEN** position during soldering. Direct flame tip away from the center of the valve. Cool valve quickly with a wet rag.
4. Solder build-up on the ball valve may prevent proper opening and closing of the valve. Rotate the manual operation button several times to loosen any possible build-up.
5. Valve body can be submerged for leak testing before the operator is attached.

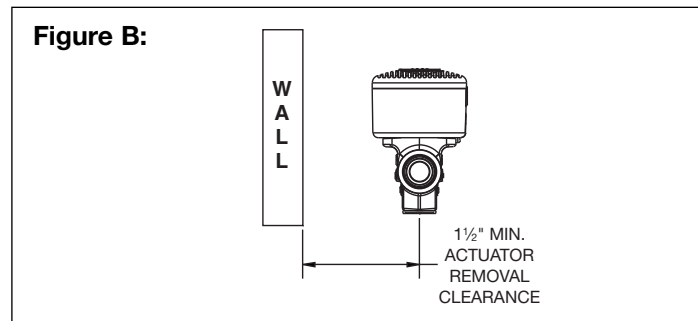
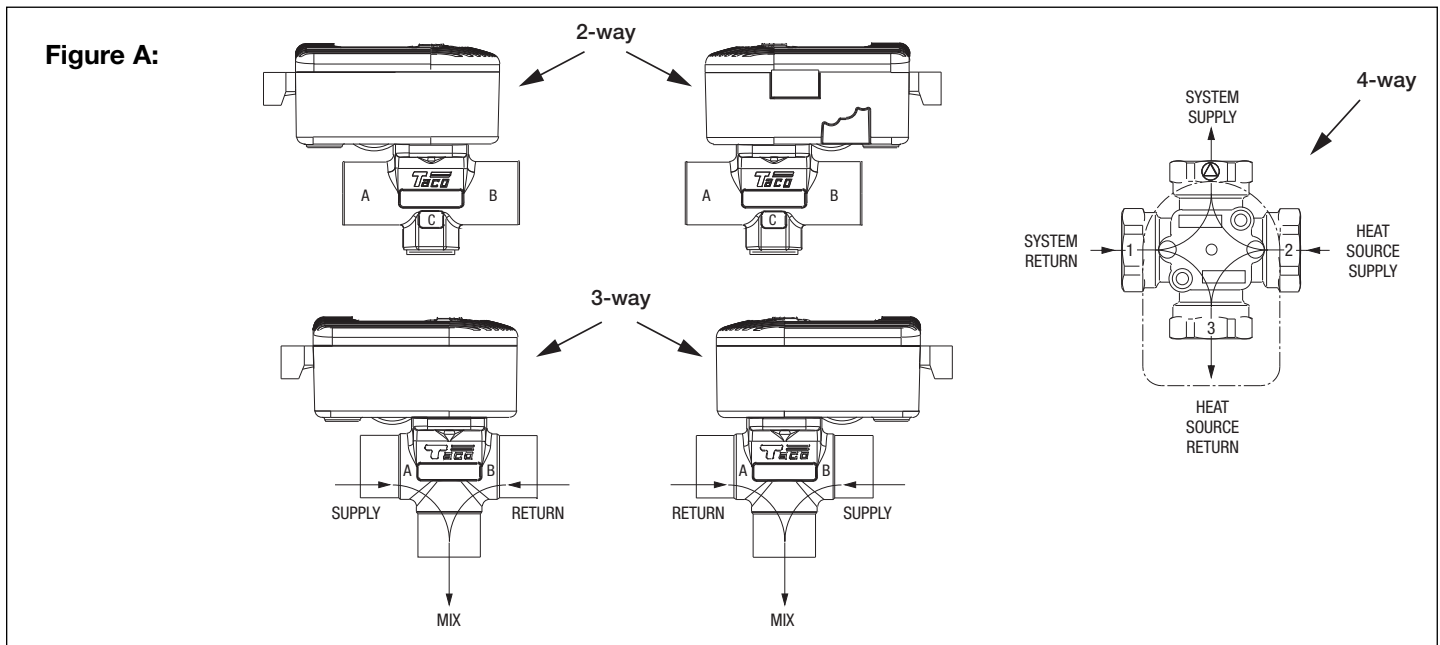

Actuator Installation / Removal

1. Valve actuator may be attached to the valve body in either direction (see Figure A). The 3-way actuator must be attached with the power connections over the supply port to ensure proper flow direction (see Figure A).
2. Actuator removal: Remove valve actuator prior to soldering by rotating the actuator counterclockwise approximately 30 degrees and lifting upward approximately 3/4" (see Figure C).
3. To re-assemble actuator to valve body: Position actuator such that the "D" shaped valve stem aligns properly with the "D" shaped actuator drive cavity (Note: The "D" shaped stem design allows for correct insertion every time). Next, slide valve stem into actuator cavity and rotate until the actuator slips over the valve's locking posts (see Figure C), once the actuator is flush with valve body, turn actuator clockwise and lock into position.

Figure C: Actuator Removal

Step 1

Rotate actuator counterclockwise approximately 30 degrees

Step 2

Move actuator upward 3/4" to disengage

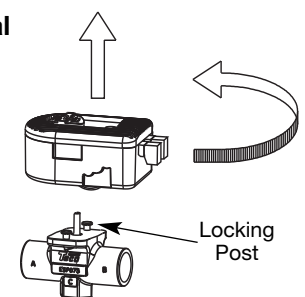

Wiring and Sensor Installation

WARNING: Wiring connections must be made in accordance with all applicable electrical codes.

CAUTION: To prevent electrical shock, disconnect electric power to system at main fuse or circuit breaker box until installation is complete. When a service switch is installed, more than one disconnect switch may be required to deenergize this device for servicing.

All terminals provided with the iSeries-S are removable. In order to prevent damage to the electronics, disconnect all plugs before the power is turned on and check voltages and sensors. Once the circuits are tested, plug in the terminals.

Powering the Control

For intermittent operation, connect one side of the end switch (e.g. Taco ZVC/SR series zone control) or thermostat to an external 24 V (ac) transformer. Connect the other side of the zone control's end switch to the R terminal on the iSeries-S. The C terminal must then be connected to the other side of the transformer. For continuous operation, simply wire the transformer directly to the R and C terminals on the iSeries-S. Ensure that no power is present during this process.

Sensors

Do not apply power to these terminals as this will damage the iSeries-S. The wiring terminals for the sensors may be removed for ease of installation.

System Supply and Boiler Return Sensors

The sensors can be strapped directly to the pipe using a cable tie. Insulation should be placed around the sensor to reduce the effect of air currents on the sensor measurement. The sensors should be placed downstream of a pump or after an elbow or similar fitting. This is especially important if large diameter pipes are used because the thermal stratification within the pipe can result in erroneous sensor readings. Proper sensor location requires that the fluid is thoroughly mixed within the pipe before it reaches the sensor.

If the system supply sensor is used to measure duct temperature, the sensor should be mounted in such a manner that it measures the average duct outlet temperature.

System Supply Sensor

Connect the two wires from the supply sensor directly into the SUPPLY and SENSOR COMMON terminals on the iSeries-S.

Boiler Return Sensor (optional - Taco part #9300-2044RP)

If a boiler return sensor is used, connect the two wires from the sensor directly into the BOILER and SENSOR COMMON terminals on the iSeries-S.

Setback Input (optional)

If a timer or setback device is used, connect the device across the SETBACK and SENSOR COMMON terminals on the iSeries-S. Setback is used to provide energy savings by lowering the target temperature.

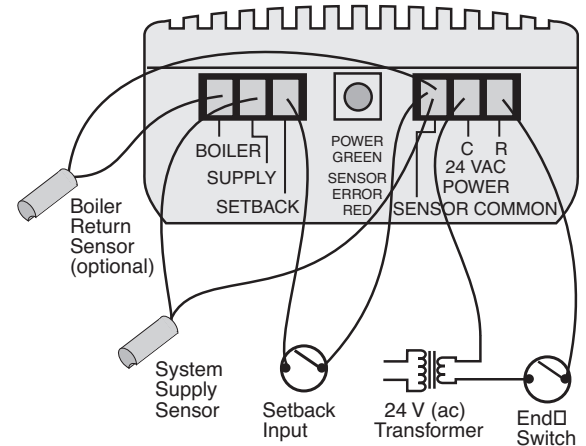

Troubleshooting

As in any troubleshooting procedure, it is important to isolate a problem as much as possible before proceeding. The error messages greatly simplify troubleshooting of the iSeries-S. When the control flashes an error message, identify the fault and follow standard testing procedures to confirm the problem. If you suspect a wiring fault, return to the wiring section on this brochure and carefully check all external wiring and wiring connections.

Multi-Status LED

LED	LED Status	iSeries-S Status
Green	Solid	Power On
Green	Flash	Reduced Output (boiler protection activated)
Red	Flash, Pause, Flash, Pause, etc.	System Supply Sensor Fault. The iSeries-S operates at a fixed output.
Red	Flash, Flash, Pause, Flash, Flash, Pause, etc.	Boiler Sensor Fault. The iSeries-S does not provide boiler protection.

Testing the Sensors

A good quality test meter capable of measuring up to 5,000 k Ω (1 k Ω = 1000 Ω) is required to measure the sensor resistance. In addition to this, the actual temperature must be measured with a good quality digital thermometer.

First measure the temperature using the thermometer and then measure the resistance of the sensor at the iSeries-S. The wires from the sensor must not be connected to the iSeries-S while this test is performed. The wiring terminals are easily removed by pulling them from the iSeries-S. Using the chart below, estimate the temperature measured by the sensor. The sensor and thermometer readings should be close. If the test meter reads a very high resistance, there may be a broken wire, a poor wiring connection or a defective sensor. If the resistance is very low, the wiring may be shorted, there may be moisture in the sensor or the sensor may be defective. To test for a defective sensor, measure the resistance directly at the sensor location.

Temperature		Resistance	Temperature		Resistance	Temperature		Resistance	Temperature		Resistance
°F	°C	Ω	°F	°C	Ω	°F	°C	Ω	°F	°C	Ω
-30	-34	234,196	30	-1	34,558	90	32	7,334	150	66	2,045
-20	-29	165,180	40	4	26,099	100	38	5,828	160	71	1,689
-10	-23	118,018	50	10	19,900	110	43	4,665	170	77	1,403
0	-18	85,362	60	16	15,311	120	49	3,760	180	82	1,172
10	-12	62,465	70	21	11,883	130	54	3,050	190	88	983
20	-7	46,218	80	27	9,299	140	60	2,490	200	93	829

Product Specifications

Maximum Operating Pressure:	300 PSI (2,100 kPa)
Maximum Shutoff Pressure:	125 PSI (875 kPa)
Fluid Temperature Range:	20° to 240°F, (-7° to 115°C) @ 135°F (57°C) ambient
Service:	Closed systems Water based, up to 50% Glycol
Seat Leakage:	Drop-Tight Close-Off, 0-125 psi (0-862 kPa) 2 & 3-way
Electrical Rating:	24 VAC \pm 10%, 60 Hz Do not exceed number of valves per transformer rating. Example: Do not use more than 4 iSeries Mixing Valves per 40VA transformer.
Power Consumption:	7.2 Watts, 0.4 Amps

Flow Coefficients

Valve Size	2-way C _v (Kv)/F _t . of Pipe Equiv.*	3-way C _v (Kv)/F _t . of Pipe Equiv.*		4-way C _v (Kv)/F _t . of Pipe Equiv.*
		Sweat & Threaded	Union	
1/2"	4.9 (4.3) / 9.5	1.5 (3.0) / 18.6	3.5 (3.0) / 18.6	—
3/4"	10.3 (8.9) / 8.4	3.5 (3.0) / 73.0	4.5 (3.9) / 44.2	7.0 (6.1) / 19
1"	8.9 (7.7) / 47.4	4.0 (3.5) / 234.9	4.5 (3.9) / 185.6	9.3 (8.1) / 44
1 1/4"	—	—	—	17.5 (15.2) / 26

* At 4' per second (maximum recommended residential flow rate).

Materials of Construction, Actuator

Body:	High Performance Engineered Polymer
Gears:	High Performance Internally Lubricated Engineered Polymer

Materials of Construction, Valve

Body:	Forged Bronze
Stem:	Brass
Press Ring:	Brass
Ball:	Brass (Chrome Plated)
Seat (2, 3-way):	Modified Teflon
O-rings:	EPDM

LIMITED WARRANTY STATEMENT

Taco, Inc. will repair or replace without charge (at the company's option) any product or part which is proven defective under normal use within one (1) year from the date of start-up or one (1) year and six (6) months from date of shipment (whichever occurs first).

Taco, Inc. will repair or replace without charge (at the company's option) any iSeries Mixing Valve body that is proven defective under normal use within three (3) years from the date of start-up or three (3) years and six (6) months from date of shipment (whichever occurs first).

In order to obtain service under this warranty, it is the responsibility of the purchaser to promptly notify the local Taco stocking distributor or Taco in writing and promptly deliver the subject product or part, delivery prepaid, to the stocking distributor. For assistance on warranty returns, the purchaser may either contact the local Taco stocking distributor or Taco. If the subject product or part contains no defect as covered in this warranty, the purchaser will be billed for parts and labor charges in effect at time of factory

examination and repair.

Any Taco product or part not installed or operated in conformity with Taco instructions or which has been subject to misuse, misapplication, the addition of petroleum-based fluids or certain chemical additives to the systems, or other abuse, will not be covered by this warranty.

If in doubt as to whether a particular substance is suitable for use with a Taco product or part, or for any application restrictions, consult the applicable Taco instruction sheets or contact Taco at [401-942-8000].

Taco reserves the right to provide replacement products and parts which are substantially similar in design and functionally equivalent to the defective product or part. Taco reserves the right to make changes in details of design, construction, or arrangement of materials of its products without notification.

TACO OFFERS THIS WARRANTY IN LIEU OF ALL OTHER EXPRESS WARRANTIES. ANY WARRANTY IMPLIED BY LAW INCLUDING

WARRANTIES OF MERCHANTABILITY OR FITNESS IS IN EFFECT ONLY FOR THE DURATION OF THE EXPRESS WARRANTY SET FORTH IN THE FIRST PARAGRAPH ABOVE.

THE ABOVE WARRANTIES ARE IN LIEU OF ALL OTHER WARRANTIES, EXPRESS OR STATUTORY, OR ANY OTHER WARRANTY OBLIGATION ON THE PART OF TACO.

TACO WILL NOT BE LIABLE FOR ANY SPECIAL, INCIDENTAL, INDIRECT OR CONSEQUENTIAL DAMAGES RESULTING FROM THE USE OF ITS PRODUCTS OR ANY INCIDENTAL COSTS OF REMOVING OR REPLACING DEFECTIVE PRODUCTS.

This warranty gives the purchaser specific rights, and the purchaser may have other rights which vary from state to state. Some states do not allow limitations on how long an implied warranty lasts or on the exclusion of incidental or consequential damages, so these limitations or exclusions may not apply to you.

 **Taco Comfort Solutions™** A Taco Group Company

Taco, Inc., 1160 Cranston Street, Cranston, RI 02920 | Tel: (401) 942-8000 | FAX: (401) 942-2360

Taco (Canada), Ltd., 8450 Lawson Road, Suite #3, Milton, Ontario L9T 0J8 | Tel: (905) 564-9422 | FAX: (905) 564-9436

Visit our web site: www.TacoComfort.com | Printed in USA | ©2015 Taco, Inc.

