



Instruction Sheet

IFSWS Industrial Flow Switch

102-026

SUPERCEDES: 102-026 DATED January 1, 2002

EFFECTIVE: March 17, 2004

#5401117-REVE



GENERAL

The IFSWS Series is a low turn radius (1.88") flow switch used in liquid flow lines carrying water or any fluid not harmful to brass, stainless steel, EPDM or fluorosilicone, and not classified as a hazardous fluid.

This switch can serve as a way to start and stop electrically operated equipment when a flow or no flow condition occurs in a variety of applications.

This device is designed for use only as an operating control. Where an operating control failure would result in personal injury and/or loss of property, it is the responsibility of the installer to add devices (safety, limit controls) that protect against, or systems (alarm, supervisory systems) that warn of control failure.

Listings/Approvals:

- UL Guide (NKPZ) for industrial control equipment per UL Standard 508 Industrial Control Equipment
- UL Guide (MFHX) for heating/cooling appliance switch per UL Standard 353 Limit Controls
- CSA Class (321106) for industrial control equipment per CSA Standard C22.2 No. 14-M Industrial Control Equipment
- CE Marked

Maximum Service Pressure: 250 PSI

Enclosure: Die-cast housing and high impact resistant polycarbonate cover. Not for use in hazardous locations.

Contacts:

- One SPDT (Form C) switch
- 10 Amps at 125/250VAC
- .5 Amps at 125VDC
- .25 Amps at 250VDC

Motor Ratings : 115VAC 230VAC

Horsepower : 1/3 1/3

AC F.L.A. : 7.2 3.6

AC L.R.A. : 43.2 21.6

Pilot Duty Rating : 332VA 120/240VAC

Environmental Specifications:

- Suitable for indoor or outdoor use with factory installed gasket and die-cast housing.
- NEMA 4 Rated Enclosure - use with appropriate conduit fitting.

Ambient Temperature Range:

32°F to 151°F (0°C to 66°C)

Media Temperature Range:

-20°F to 250°F (-29°C to 121°C)

Pipe Connection:

IFSWSB: 1 in. NPT Brass

IFSWS: 1 in. NPT 316 Stainless Steel

Conduit Entrance: One opening for 1/2" conduit

Usage: For pipe sizes 1" - 8"

Caution: This device is not intended for applications in explosive environments.

MOUNTING AND INSTALLATION

The IFSWS Series may be mounted in a horizontal pipe line or a vertical pipe line with upward liquid flow. It is not recommended for installations where flow is downward. When mounted in a horizontal pipe line the switch should be mounted on the top side of the pipe where it will be accessible. The switch will trip at a lower flow rate than shown in Table 1.

Mount the device in a section of pipe where there is a straight run of at least 5 pipe diameters on each side of the flow switch. Do not locate adjacent to valves, elbows or orifices. The switch should be mounted so the terminals or wire leads are easily accessible for wiring.

IFS models with flexible paddles are furnished with 4 paddles. Rigid paddle models are furnished with 2 paddles. For pipe sizes 1", 2", 3", 6" and 8", use the paddles provided. Intermedi-

ate sizes may be trimmed from the appropriate paddle using the paddle template in Fig. 5. The paddle must not touch the inside of the pipe or bind in any way. Paddles smaller than the actual pipe size should be used for added support and higher sensitivity, see Fig. 3. The paddles must be properly attached and the screw that holds the paddle must be securely tightened.

For a 1" pipe application mount in a standard 1"x1"x1" tee. Use a reducing tee for larger sizes of pipe to keep flow switch close to pipe and provide adequate paddle length in the flow stream.

Example: Use a 2"x2"x1" tee for 2" pipe. A weldolet may also be used. Screw the device into the tee fitting as shown in Fig. 4. The flat of the paddle must be at a right angle to the flow. The arrow on the side of the bushing must point in the direction of flow, see Fig. 1.

FIG. 1

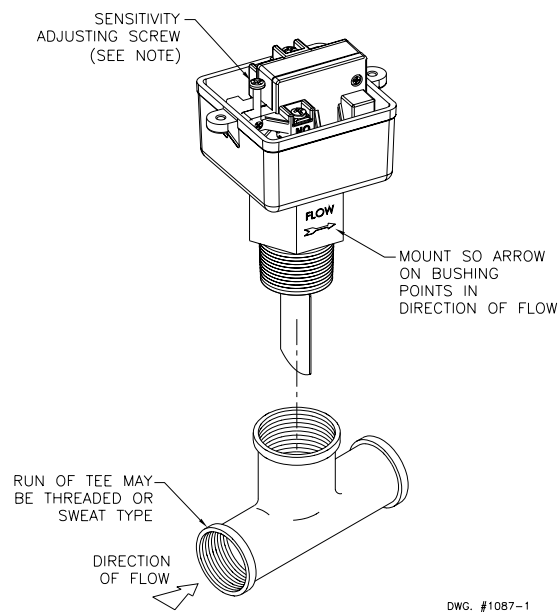
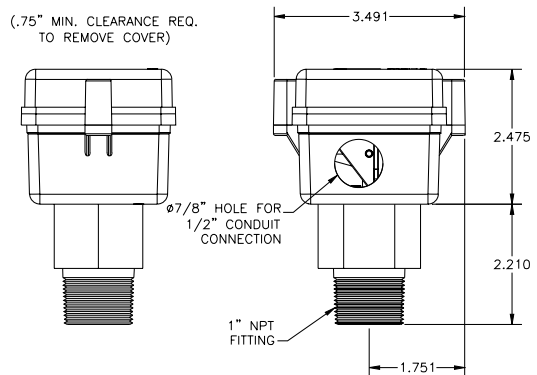

FIG. 2



Turn radius = 1.88"

Sensitivity Adjustment Note:

Turn sensitivity screw clockwise to increase the flow rate required to activate the switch.

Turn sensitivity screw counter-clockwise to decrease the flow rate required to activate the switch.

FIG. 3

Typical paddle arrangement for 6" to 8" pipe, using smaller flexible paddles for added support and higher sensitivity.

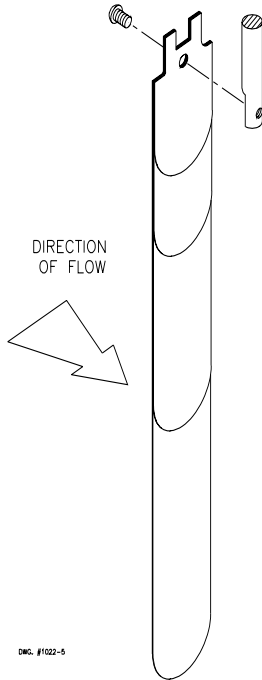

FIG. 5

Use the drawing at right as a template and cut at the dotted arc when trimming the appropriate paddle for intermediate pipe sizes.

CAUTION:
The paddle must not touch the inside of the pipe or bind in any way.

NOTE:
When installing **rigid paddles**, do not stack paddles. Only install **ONE** paddle that best fits the pipe.

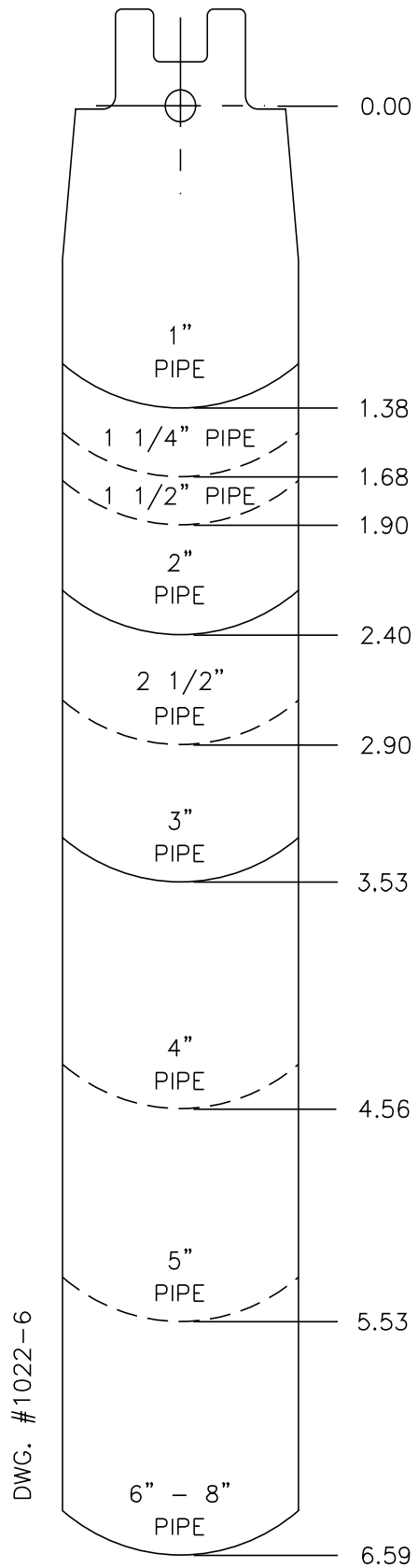
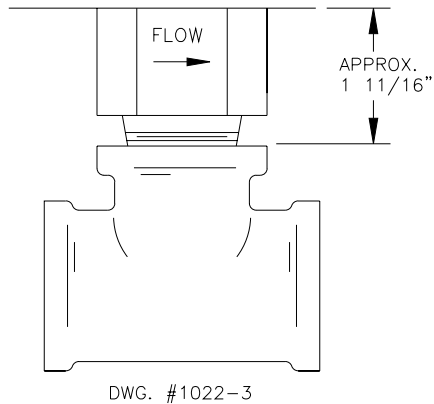

FIG. 4



CAUTION:
Screw the device into the TEE fitting as shown. Care must be taken to properly orient the device for the direction of the flow. Do not tighten by grasping the switch enclosure. Use the wrenching flats on the bushing only. Turning radius required for mounting the IFSWS is 1.88".

WIRING

Use properly rated temperature supply wire for the anticipated service temperature.

Make all electrical connections in accordance with the National Electrical Code and local regulations.

See Fig. 6 for diagram illustrating switch action.

ADJUSTMENT

Remove switch cover and turn the sensitivity adjusting screw clockwise to increase the flow rate required to actuate the switch. Turn the

sensitivity adjusting screw counter-clockwise to decrease the flow rate required to actuate the switch. (See Fig. 6.) Be sure to replace the cover upon completion of the installation and adjustment.

CAUTION: Check the installation for "no-flow" switch operation. Make appropriate adjustments to the sensitivity adjustment screw to be sure the switch restores fully at the desired flow rate.

FIG. 6

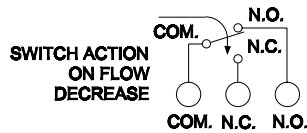

SWITCH INFORMATION

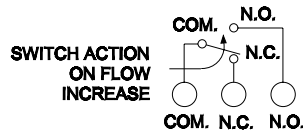

NOTE: Turn sensitivity screw clockwise to increase the flow rate required to activate the switch. Turn sensitivity screw counter-clockwise to decrease the flow rate required to activate the switch.

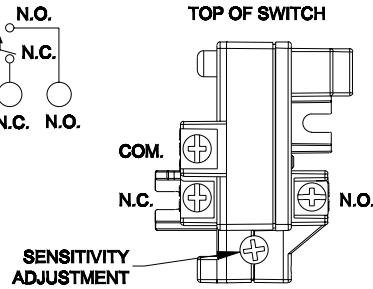

DWG. #1041-5

TABLE 1

SPECIFICATIONS											
Typical Flow Rates-GPM Required to Actuate Switch (For vertical pipe installations)											
Pipe Size (inches)		1	1 1/4	1 1/2	2	2 1/2	3	4	*5	6	*8
Minimum Adjustment	Flow Increase	4.5	4.5	6.0	7.5	13.5	18	35	50	70	210
	Flow Decrease	3.5	3.5	5.0	5.5	9.5	13	25	40	60	190
Maximum Adjustment	Flow Increase	9.5	10.0	13.5	20.0	29.0	50	70	120	180	410
	Flow Decrease	7.0	8.5	10.5	18.5	26.0	45	65	105	160	380

NOTES:

1. Typical flow rates for 1" to 1 1/2" pipe sizes are averages which may vary approximately ± 1 GPM with the use of a bronze reducing tee.
2. Typical flow rates for 2" to 8" pipe sizes are averages which may vary $\pm 10\%$ with the use of a 1" weldolet.

(*) Flow rates for these sizes are calculated.

IFS Ordering

I F S W S - 1

Process Connection
F Flexible Paddles
R Rigid Paddles

Bushing Material
B Brass
S 316 Stainless Steel

Model
WS NEMA 4, Small Turning Radius

Paddle Kit Only Ordering

P - 1

Paddle Style
F Standard Flexible
R Rigid

Taco Comfort Solutions™ A Taco Group Company

Taco, Inc., 1160 Cranston Street, Cranston, RI 02920 | Tel: (401) 942-8000 | FAX: (401) 942-2360

Taco (Canada), Ltd., 8450 Lawson Road, Suite #3, Milton, Ontario L9T 0J8 | Tel: (905) 564-9422 | FAX: (905) 564-9436

Visit our web site: www.TacoComfort.com | Printed in USA | ©2015 Taco, Inc.

