

RELAY KIT INSTALLATION FOR MULTIPLE UNIT CONTROL

OPTIONS CL31 AND CL32 FOR ELECTRIC UNIT HEATER MODEL EUH, DESTRATIFICATION FAN MODEL H, GAS-FIRED DOWNFLOW HEATER MODEL LDAP, AND GAS-FIRED UNIT HEATER MODELS UBX, UBXC, UBZ, UDX, UDXC, UDXZ, AND UEZ

⚠ CAUTION ⚠

- DO NOT use these multiple unit control options with a two-stage thermostat.
- These instructions are designed to assist a qualified electrician in installing this multiple unit control kit. For maximum safety, the control is installed in the low voltage circuit. Interruption of the supply voltage is not recommended.
- All electrical wiring and connections, including electrical grounding, MUST be in accordance with the *National Electric Code* (ANSI/NFPA No. 70, latest edition) or, in Canada, the *Canadian Electric Code* (Part 1, CSA C.22.1, latest edition). In addition, the installation must comply with local ordinances and applicable gas company requirements.
- These relay kits are designed to permit the control of up to five units (one control unit and up to four additional non-control units) with one single-stage thermostat or with a time clock and one or more single-stage thermostats.
- Refer to the installation manual provided with the unit for important safety information.

KIT COMPONENTS

NOTE: Option CL31 includes components for one control unit and one additional unit. Option CL32 includes components for each additional non-control unit. Not all kit components will be used on all models.

Ensure that all components listed in [Table 1](#) or [Table 2](#) are available before beginning installation.

Table 1. Kit Components (Models EUH and LDAP)

Item No.	Component	Description	Option						
			CL31			CL32			
			Model						
			LDAP	EUH (208V-240V)	EUH (277V)	EUH (480V)	EUH (600V)	LDAP	EUH
			Kit PN						
1041280	1042927	1047587	1042928	1047588	1041286	1041287			
Component PN (Quantity)									
1	Assembly	Relay	208365* (2)	197157** (2)			208365* (1)	197157** (1)	
2	Screw		38529 (4)	195249 (4)			38529 (2)	195249 (2)	
3	Cable clamp	3/16	—	16228 (2)			—	16228 (1)	
4	Label	Wiring diagram	197164 (2)				197164 (1)		
5	Transformer	30VA	—	1042451 (1)	—	258912 (1)	—		
		40VA	—	621709 (1)	—	202661 (1)			
6	Wiring harness	Assembly	1042929 (1)						

*Includes relay(s) (PN 18549), 24VAC DPDT plug(s) (PN 211411), and socket(s) with wires and terminals (PN 211415). If replacing a previously-used relay only (PN 98118) on an LDAP unit, order replacement kit PN 263527.
 **Includes relay (PN 18549) and bracket.

DO NOT DESTROY. PLEASE READ CAREFULLY. KEEP IN A SAFE PLACE FOR FUTURE REFERENCE.

KIT COMPONENTS—CONTINUED

Table 2. Kit Components (Models H, UBX, UBXC, UBZ, UDX, UDXC, UDZ, and UEZ)								
Item No.	Component	Description	Option					
			CL31		CL32			
			Model					
			H, UBX, UBXC, UBZ		UDX, UDXC, UDZ, UEZ		H, UBX, UBXC, UBZ, UDX, UDXC, UDZ, UEZ	
			Kit PN					
			1041281		1041288		1041287	
Component PN (Quantity)								
1	Assembly*	Relay	197157 (2)		197157 (1)			
2	Screw		195249 (4)		195249 (2)			
3	Cable clamp	3/16	16228 (2)		16228 (1)			
4	Label	Wiring diagram	197164 (2)		197164 (1)			
5	Transformer	40VA	—		194808 (1)			
6	Wiring harness	Assembly	—		197160 (1)			

*Includes relay (PN 18549) and bracket.

INSTALLATION

Install the relay kit as follows. Item numbers in parentheses refer to [Table 1](#) or [Table 2](#).

1. For gas-fired units, turn OFF gas and electric power. For electric units, turn OFF electric power.
2. Install/replace transformer (if required) on control unit:
 - a. For electric unit heater model EUH:
 - (1) Remove control compartment access panel.
 - (2) Position transformer (5) as shown in [Figure 1](#), DETAIL A and secure transformer using self-tapping screws (2).
 - (3) Connect wires for transformer (5) in accordance with [Figure 1](#), DETAIL B.
 - (4) Install control compartment access panel

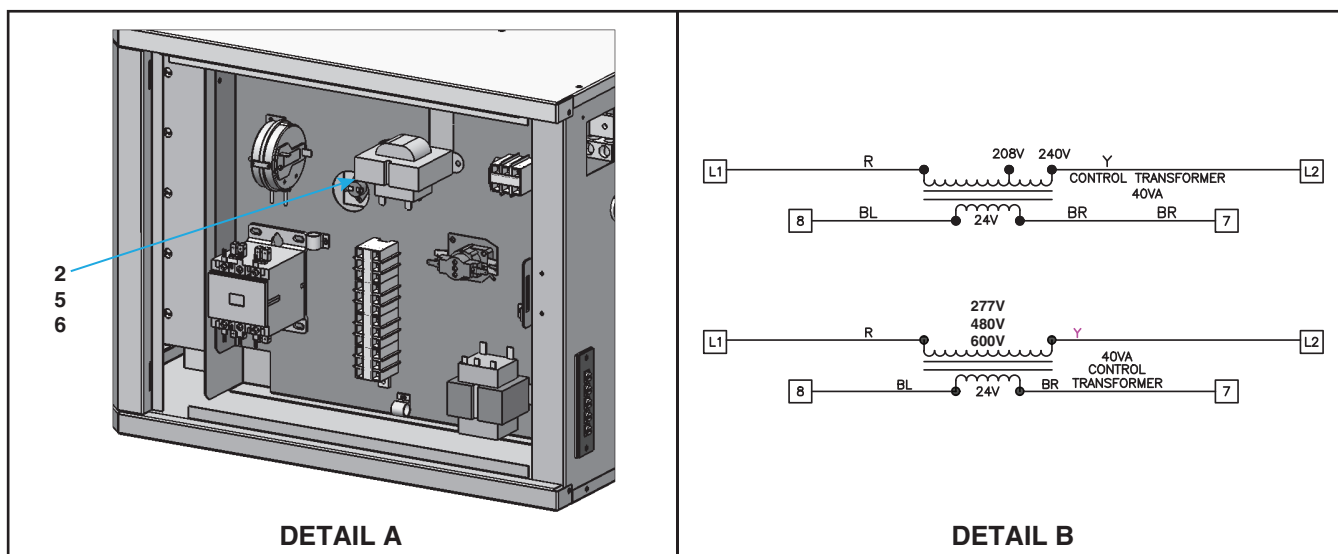

Figure 1. Transformer Location (Typical) and Wiring—Model EUH (Refer to [Table 1](#))

- b. For gas-fired unit heater models UDX, UDXC, UDX, and UEZ:
 - (1) Remove control compartment access panel and locate existing transformer (see [Figure 2](#)) mounted on control board at bottom of control compartment for unit size 130–310 UEZ and all UDX, UDXC, and UDX models.
 - (2) Mark and disconnect transformer wires
 - (3) Remove screws that secure existing transformer and remove transformer.
 - (4) Install replacement transformer (5) with wiring harness (6) and secure using existing screws.
 - (5) Reconnect transformer wires in accordance with wiring diagram provided with unit.
 - (6) Install control compartment access panel.

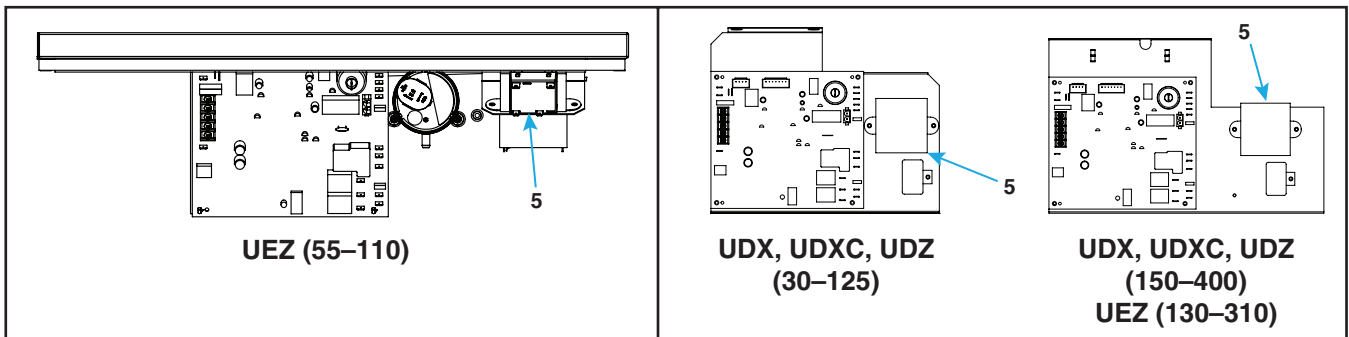

Figure 2. Transformer Location—Models UDX, UDXC, UDX, and UEZ (Refer to [Table 2](#))

- 3. Install relay on control unit and on all non-control units:
 - a. For electric unit heater model EUH (see [Figure 3](#)):
 - (1) At rear of heater, remove and save screws from edge of cabinet bottom.
 - (2) Secure relay assembly (1) as shown using existing screws.

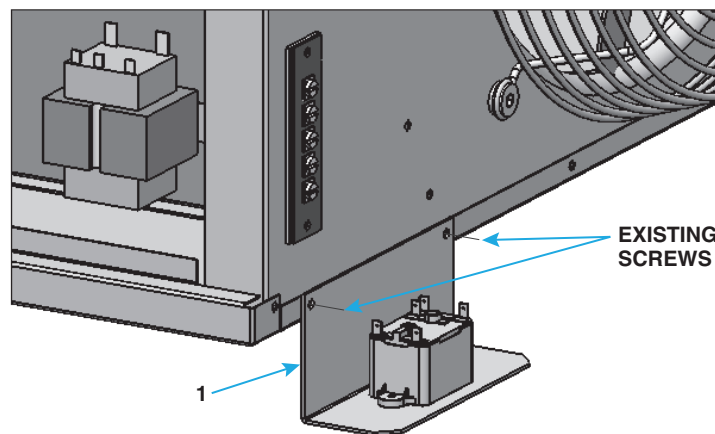

Figure 3. Relay Installation—Model EUH (Refer to [Table 1](#))

INSTALLATION—CONTINUED

- b. For destratification fan model H, disassemble relay assembly (1) by removing relay from bracket and secure relay as shown in **Figure 4** using two screws (2). Bracket will not be used.

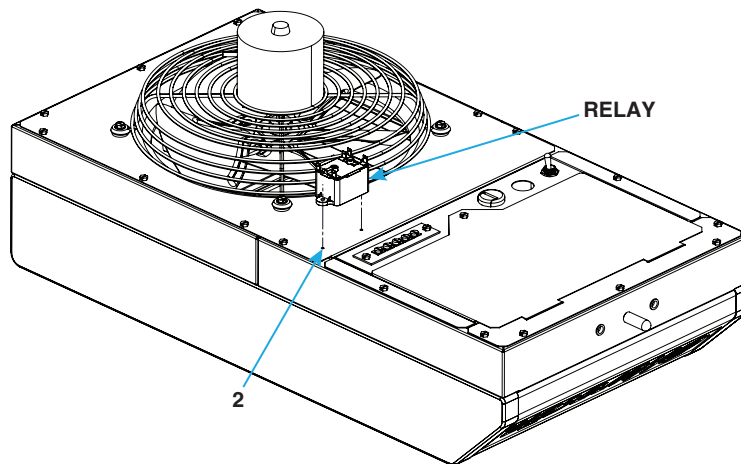

Figure 4. Relay Installation—Model H (Refer to Table 2)

- c. For gas-fired downflow heater model LDAP:
- (1) Remove control compartment access panel from main heat section.
 - (2) Position relay assembly (1) as shown in **Figure 5** and secure using screws (2).
 - (3) Install control compartment access panel.

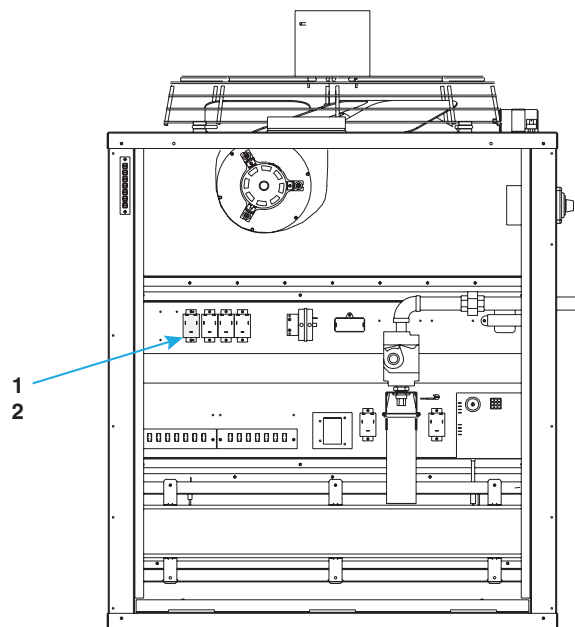

Figure 5. Relay Installation—Model LDAP (Refer to Table 1)

- d. For gas-fired unit heater models UBX, UBXC, UBZ, UDX, UDXC, UDZ, and UEZ (see [Figure 6](#)):
- (1) At rear of heater, remove and save screws from edge of cabinet bottom.
 - (2) For model UBX, UBXC, UBZ, UDX, UDXC, and UDZ unit sizes 150–400 and all UEZ models, align relay assembly (1) as shown and use bracket as template to drill hole in edge of cabinet bottom as shown.
 - (3) Secure relay assembly (1) and cable clamp (3) as shown using existing screws for model UBX, UBXC, UBZ, UDX, UDXC, and UDZ unit sizes 30–125 or one existing screw and one screw (2) from kit for model UBX, UBXC, UBZ, UDX, UDXC, and UDZ unit sizes 150–400 and all UEZ models.

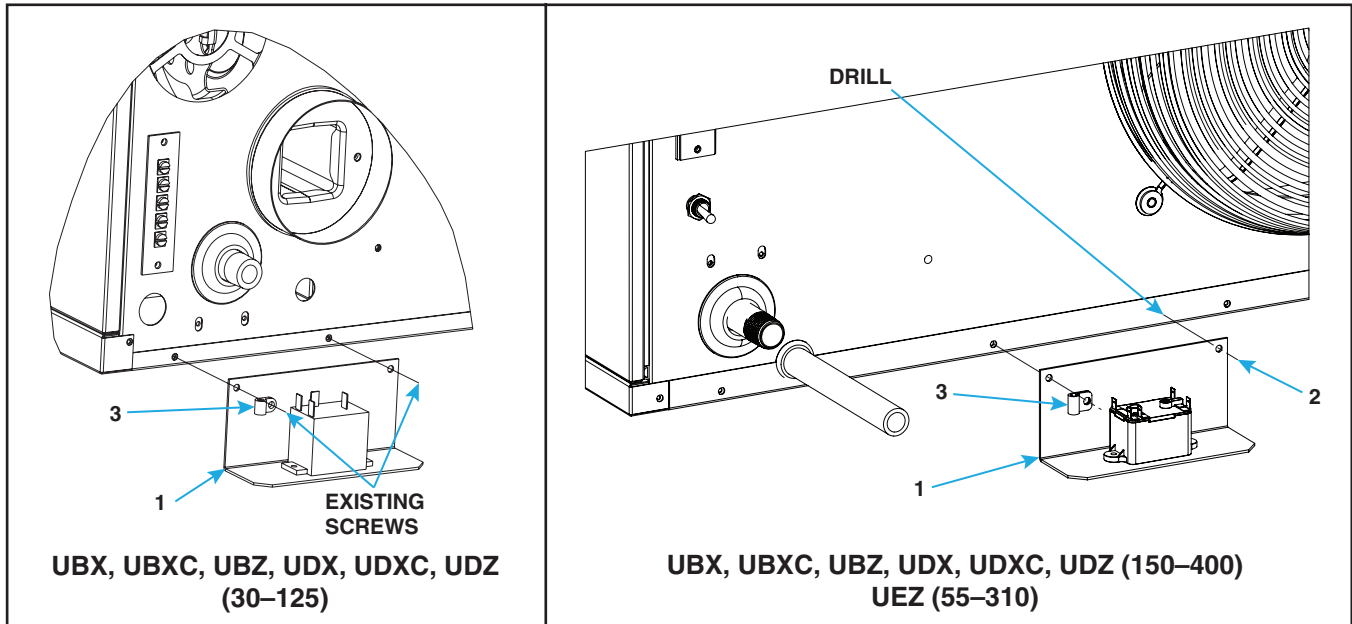

Figure 6. Relay Installation—Models UBX, UBXC, UBZ, UDX, UDXC, UDZ, and UEZ (Refer to [Table 2](#))

4. Determine control wiring configuration. Do not exceed length and distance listed in [Table 3](#).

Table 3. Control Wiring Specifications		
Size (AWG)	Maximum Length*	Maximum Distance
	Feet (Meters)	
12	2100 (640)	1050 (320)
14	1300 (457)	650 (198)
18	500 (152)	250 (76)

*For complete circuit.

INSTALLATION—CONTINUED

⚠ CAUTION ⚠

Be careful NOT TO short thermostat leads to a metal surface. Doing so will cause the transformer to fail and require replacement.

5. Connect TEW-type control wiring to relay terminals in accordance with **Figure 7**.

CHECK APPROPRIATE BOX:
CONTROL UNIT NON CONTROL UNIT

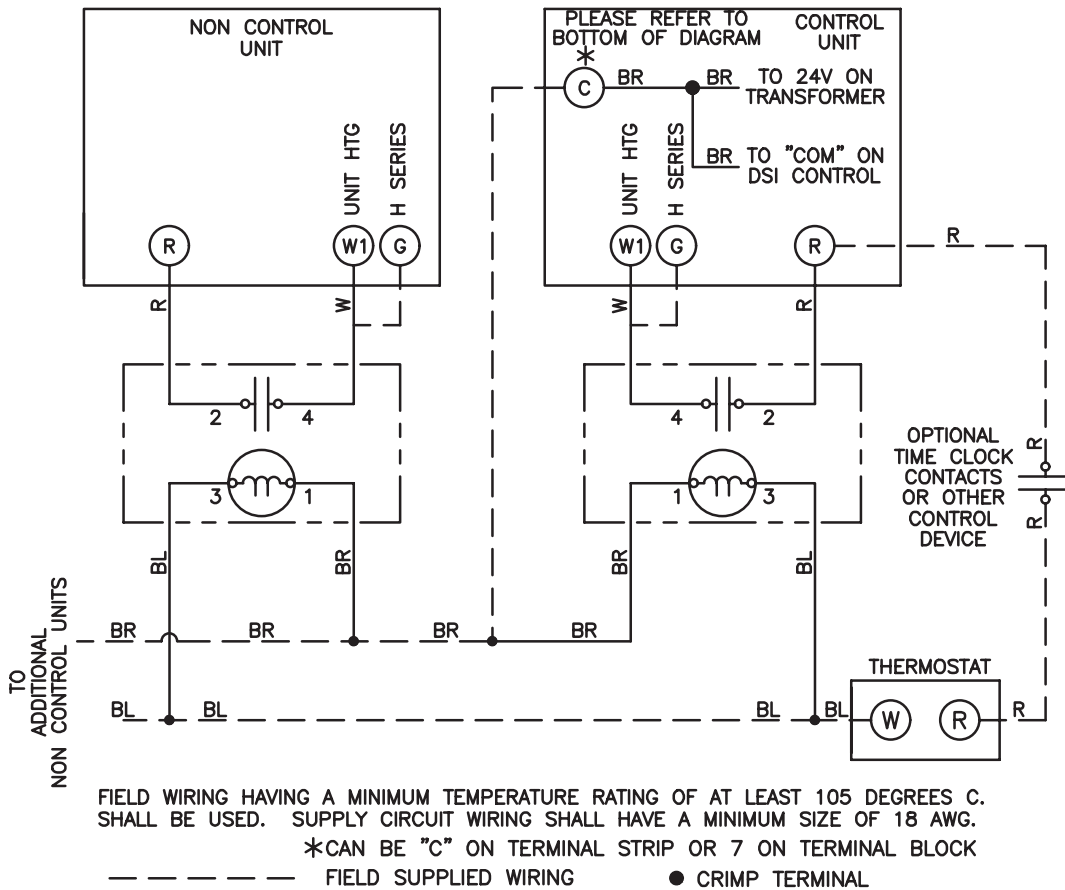

Figure 7. Multiple Unit Control Wiring Diagram

6. Install wiring diagram label:
- a. For future reference, check appropriate box—for CONTROL UNIT or NON CONTROL UNIT—on wiring diagram label (4).
 - b. Determine wiring diagram label position.
 - c. Wipe surface with clean, dry cloth.
 - d. Remove label backing and adhere label to unit.
7. Restore system to service:
- a. For gas-fired units, turn ON gas and electric power. For electric units, turn ON electric power.
 - b. Check for proper operation.

NOTES

