

INSTALLATION AND OWNER'S MANUAL

M-thermal Split
Outdoor Unit

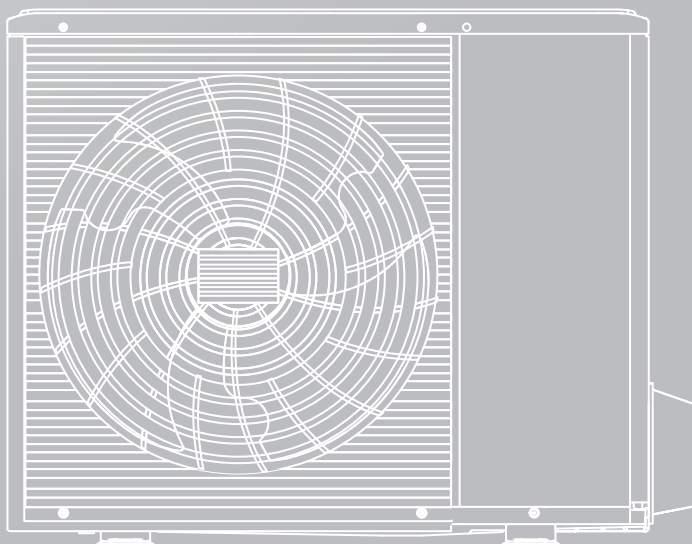

IMPORTANT NOTE:



Original instructions.

Please read this manual carefully and keep it for future reference.

All the pictures in this manual are for illustrations purpose only.

CONTENTS

1 SAFETY PRECAUTIONS	02
2 ACCESSORIES	11
2.1 Overview of the unit	11
2.2 Accessories supplied with the unit	13
3 BEFORE INSTALLATION	14
4 INSTALLATION SITE	15
4.1 Selecting a location in cold climates	16
4.2 Prevent sunshine	16
5 UNIT INSTALLATION	17
5.1 Dimensions	17
5.2 Installation requirements	17
5.3 Drain hole position	18
5.4 Installation space requirements	18
6 PIPING INSTALLATION	19
6.1 Refrigerant piping	19
6.2 Leakage detection	20
6.3 Heat insulation	21
6.4 Connecting method	21
6.5 Remove dirt or water in the pipes	22
6.6 Airtight testing	22
6.7 Air purge with vacuum pump	22
6.8 Refrigerant amount to be added	22
7 WIRING	23
7.1 Precautions on electrical wiring work	23
7.2 Precautions on wiring of power supply	23
7.3 Safety device requirement	24
7.4 Remove the switch box cover	24
7.5 To finish the outdoor unit installation	25

8 TEST RUNNING	25
9 PRECAUTIONS ON REFRIGERANT LEAKAGE	25
10 HAND-OVER	28
11 OPERATION AND PERFORMANCE	30
11.1 Protection equipment	30
11.2 About power cut	30
11.3 Heating capacity	30
11.4 Compressor protection feature	30
11.5 Cooling and heating operation	30
11.6 Features of heating operation	30
11.7 Defrost in the heating operation	30
11.8 Error codes	31
12 TECHNICAL SPECIFICATIONS	36
13 DISPOSAL	36
ANNEX A: REFRIGERANT CYCLE	37
ANNEX B:	38
TO INSTALL THE E-HEATING TAPE AT THE DRAIN OUTLET (FIELD INSTALLATION)	

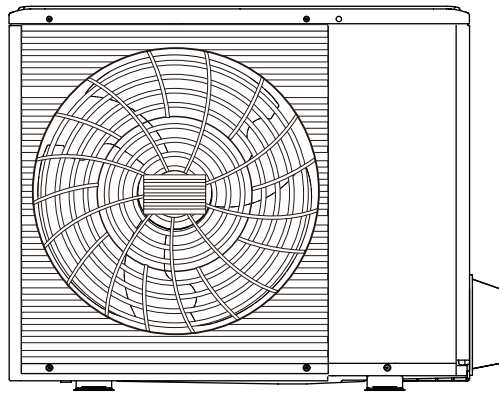

12/14/16 kW

Wiring diagram: 12/14/16 kW for example

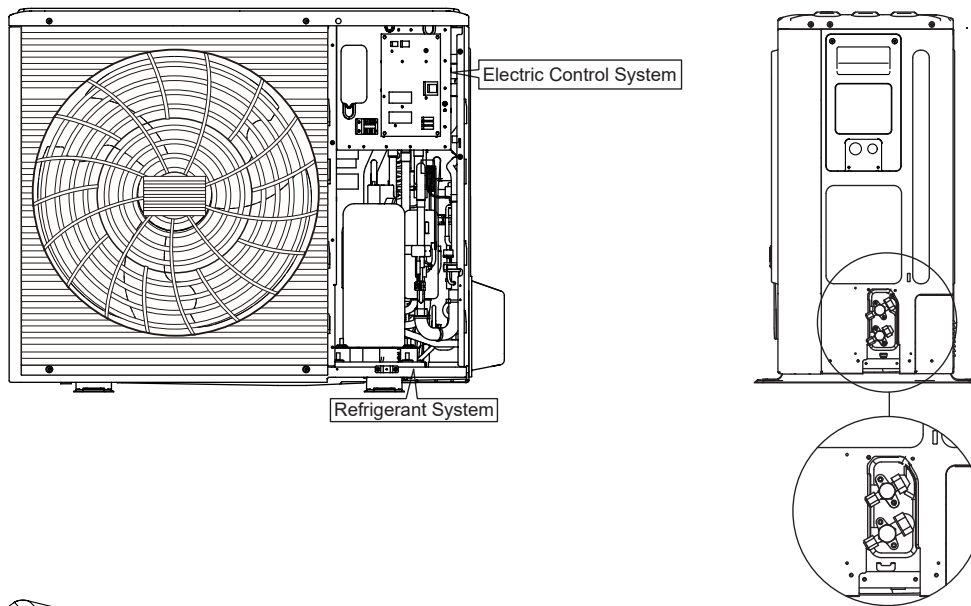

12/14/16 kW

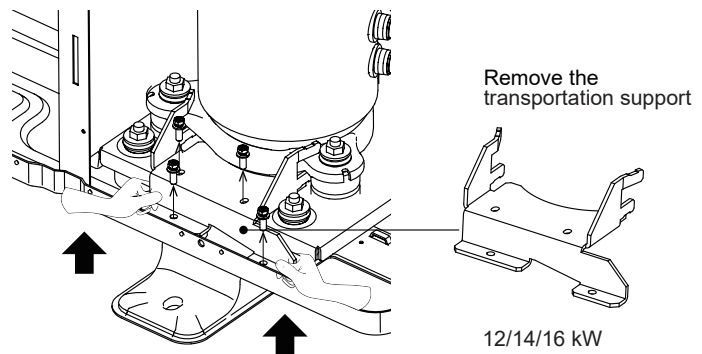
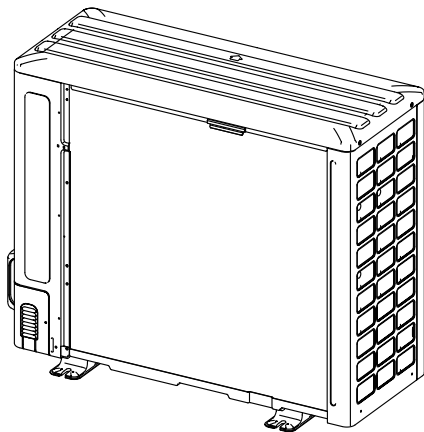

NOTICE

- Please remove the noise insulation cover of the compressor first.
- Please make sure the transportation support had be removed.
- It will cause heat pump abnormal vibration and noise if running with transportation support for compressor installed.
- Please wear gloves when doing the above operation to prevent hand scratches.
- Please restore the noise insulation cover after removing the transportation support.

1 SAFETY PRECAUTIONS

The precautions listed here are divided into the following types. They are quite important, so be sure to follow them carefully. Meanings of DANGER, WARNING, CAUTION and NOTICE symbols.

⚠ WARNING

- Read these instructions carefully before installation. Keep this manual handy for future reference.
- Improper installation of equipment or accessories may result in electric shock, short-circuit, leakage, fire or other damage to the equipment. Be sure to only use accessories made by the supplier, which are specifically designed for the equipment and make sure to get installation done by a professional.
- All the activities described in this manual must be carried out by a licensed technician. Be sure to wear adequate personal protection equipment such as gloves and safety glasses while installing the unit or carrying out maintenance activities.
- Contact your dealer for any further assistance.



⚠ WARNING

Servicing shall only be performed as recommended by the equipment manufacturer. Maintenance and repair requiring the assistance of other skilled personnel shall be carried out under the supervision of the person competent in the use of flammable refrigerants.

Hazard Definitions

The following defined terms are used throughout this manual to bring attention to the presence of hazards of various risk levels or to important information concerning the life of the product .

⚠ DANGER

DANGER indicates a hazardous situation which, if not avoided, will result in death or serious injury.

⚠ WARNING

WARNING indicates a hazardous situation which, if not avoided, could result in death or serious injury.

⚠ CAUTION

CAUTION indicates a hazardous situation which, if not avoided, could result in minor or moderate injury.



💡 NOTICE



NOTICE is used to address practices not related to physical injury.

SAFETY INSTRUCTIONS

Safety instruction(or equivalent) signs indicate specific safety-related instructions or procedures.

Explanation of symbols displayed on the unit

	DANGER	This symbol shows that this appliance uses a mild flammable refrigerant. If the refrigerant leaks and is exposed to an external ignition source, there is a risk of fire.
	WARNING	This symbol shows that appliance shall be installed, operated and stored in a room with a floor area not less than the minimum room area.
	CAUTION	This symbol shows that the operation manual should be read carefully.

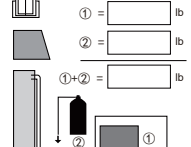
	CAUTION	This symbol shows that service personnel should be handling this equipment with reference to the installation manual.
	CAUTION	This symbol shows that information is available such as the operating manual or installation manual.
	CAUTION	This symbol shows that adding refrigerant charge to the system must be added together to the system's pre-charged level in order to find the new full system charge. Record the result of the added charge with the pre-charge level to get the new full refrigerant charge of the system

⚠ DANGER

- Before touching electric terminal parts, turn off power switch.
- When service panels are removed, live parts can be easily touched by accident.
- Never leave the unit unattended during installation or servicing when the service panel is removed.
- Do not touch water pipes during and immediately after operation as the pipes may be hot and could burn your hands. To avoid injury, give the piping time to return to normal temperature or be sure to wear protective gloves.
- Do not touch any switch with wet fingers. Touching a switch with wet fingers can cause electrical shock.
- Before touching electrical parts, turn off all applicable power to the unit.

⚠ WARNING

- Tear apart and throw away plastic packaging bags so that children will not play with them. Children playing with plastic bags face danger of death by suffocation.
- Safely dispose of packing materials such as nails and other metal or wood parts that could cause injuries.
- Ask your dealer or qualified personnel to perform installation work in accordance with this manual. Do not install the unit yourself. Improper installation could result in water leakage, electric shocks, or fire.
- Be sure to use only specified accessories and parts for installation work. Failure to use specified parts may result in water leakage, electric shocks, fire, or the unit falling from its mount.
- Install the unit on a foundation that can withstand its weight. Insufficient physical strength may cause the equipment to fall and possibly cause injury.
- Perform specified installation work with full consideration of strong wind, hurricanes, or earthquakes. Improper installation work may result in accidents due to equipment falling.
- Make certain that all electrical work is carried out by qualified personnel according to the local laws and regulations and this manual using a separate circuit. Insufficient capacity of the power supply circuit or improper electrical construction may lead to electric shocks or fire.
- Be sure to install a ground fault circuit interrupter according to local laws and regulations. Failure to install a ground fault circuit interrupter may cause electric shocks and fire.
- Make sure all wiring is secure. Use the specified wires and ensure that terminal connections or wires are protected from water and other adverse external forces. Insecure connection may cause a fire.
- When wiring the power supply, form the wires so that the front panel can be securely fastened. If the front panel is not in place there could be overheating of the terminals, electric shocks or fire.
- After completing the installation work, check to make sure that there is no refrigerant leakage.
- Never directly touch any leaking refrigerant as it could cause severe frostbite. Do not touch the refrigerant pipes during and immediately after operation as the refrigerant pipes may be hot or cold, depending on the condition of the refrigerant flowing through the refrigerant piping, compressor and other refrigerant cycle parts. Burns or frostbite are possible if you touch the refrigerant pipes. To avoid injury, give the pipes time to return to normal temperature or, if you must touch them, be sure to wear protective gloves.
- Do not touch the internal parts (pump, backup heater, etc.) during and immediately after operation. Touching the internal parts can cause burns. To avoid injury, give the internal parts time to return to normal temperature or, if you must touch them, be sure to wear protective gloves.
- Installation and service work should only be done by a qualified technician.
- Examples for such working procedures are: breaking into the refrigerating circuit; Opening of sealed components; Opening of ventilated enclosures.

⚠ WARNING

Do not use means to accelerate the defrosting process or to clean, other than those recommended by the manufacturer.

Do not pierce or burn the unit.

Be aware that refrigerants may not contain an odor.

⚠ WARNING

This appliance is not intended for use by persons (including children) with reduced physical, sensory or mental capabilities, or persons who lack experience and knowledge, unless they are supervised or have been given instructions concerning the use of the appliance by a person responsible for their safety.

Children should be supervised to ensure that they do not play with the appliance.

Any person who is involved with working on or opening a refrigerant circuit should hold a current valid certificate from an industry-accredited assessment authority, which authorizes their competence to handle refrigerants safely in accordance with an industry recognized assessment credential.

Servicing shall only be performed as recommended by the equipment manufacturer.

Maintenance and repair requiring the assistance of other skilled personnel shall be carried out under the supervision of a person competent in the use of flammable refrigerants.

Prior to beginning work on systems containing flammable refrigerants, safety checks are necessary to minimize the risk of ignition.

⚠ WARNING

The following precautions should be complied with when installation, service, maintenance / repair, and decommissioning of appliances using flammable refrigerant.

General

This appliance contains A2L flammable refrigerant R32.

Installation

⚠ WARNING

Every working procedure that affects safety means shall only be carried out by qualified technician.

Examples for such working procedures are:

- breaking into the refrigerating circuit;
- opening of sealed components;
- opening of ventilated enclosures.

General

⚠ WARNING

- **Pipe-work shall be in compliance with national and local codes and standards.**
- The pipe-work including piping material, pipe routing, and installation shall include protection from physical damage in operation and service, and be in compliance with national and local codes and standards, such as ASHRAE 15, ASHRAE 15.2, IAPMO Uniform Mechanical Code, ICC International Mechanical Code, or CSA B52. All field joints shall be accessible for inspection prior to being covered or enclosed;
- After completion of field piping for split systems, the field pipework shall be pressure tested with an inert gas and then vacuum tested prior to refrigerant charging, according to the following requirements;

⚠ WARNING

- The minimum test pressure for the low side of the system shall be the low side design pressure and the minimum test pressure for the high side of the system shall be the high side design pressure, unless the high side of the system, cannot be isolated from the low side of the system in which case the entire system shall be pressure tested to the low side design pressure.
 - Field-made refrigerant joints indoors shall be tightness tested. The test method shall have a sensitivity of 0.012 lbs(5.44 g) per year of refrigerant or better under a pressure of at least 0,25 times the maximum allowable pressure. No leak shall be detected;
 - Taking into consideration the length and diameter of the connecting refrigerant piping, add refrigerant to complete the installation according to the information provided in the IDU product manual for determining the required additional refrigerant charge, as well as the instructions in this manual on how to complete the refrigerant charge.
- The minimum INSTALLED HEIGHT shall comply with the corresponding requirements in this manual.
- Protection devices, piping and fittings shall be protected as far as possible against adverse environmental effects, for example the danger of water collecting and freezing in relief pipes or the accumulation of dirt and debris;
- Provision shall be made for expansion and contraction of long runs of piping;

⚠ WARNING

This appliance contains FLAMMABLE REFRIGERANTS, the minimum floor area of the room shall comply with the requirements in the " Required Minimum Room Area" table within this manual;

The detailed information on the following topics is included in the manual:

- function, operation and required servicing measures;
- specified end-of-life and replacement instructions;

Unventilated areas

⚠ WARNING

The appliance contains more than m1 for any refrigerating circuit, an unventilated area where the appliance using FLAMMABLE REFRIGERANTS is installed shall be so constructed that should any refrigerant leak, it will not stagnate so as to create a fire or explosion hazard.

The appliance shall be stored in an area where the room size corresponds to the room area as specified for operation;

The appliance shall be stored in a room without continuously operating open flames (for example an operating gas appliance) or other POTENTIAL IGNITION SOURCES (for example an operating electric heater, hot surfaces);

The appliance shall be stored so as to prevent mechanical damage from occurring.

Information on servicing

General

⚠ CAUTION

Servicing shall **Be Performed Only By Trained and Certified Service Personnel.**

Checks to the area

Prior to beginning work on systems containing flammable refrigerants, safety checks are necessary to ensure that the risk of ignition is minimized. For repair to the refrigerating system, Clause "Work procedure" to Clause "No ignition sources" shall be completed prior to conducting work on the system.

Work procedure

Work shall be undertaken under a controlled procedure so as to minimize the risk of a flammable gas or vapor being present while the work is being performed.

General work area

All maintenance staff and others working in the local area shall be instructed on the nature of work being carried out. Work in confined spaces shall be avoided.

The area around the workspace shall be sectioned off. Ensure that the conditions within the area have been made safe by control of flammable material.

Checking for presence of refrigerant

The area shall be checked with an appropriate refrigerant detector prior to and during work, to ensure the technician is aware of potentially toxic or flammable atmospheres. Ensure that the leak detection equipment being used is suitable for use with all applicable refrigerants, i.e. non-sparking, adequately sealed or intrinsically safe.

Presence of fire extinguisher

If any hot work is to be conducted on the refrigerating equipment or any associated parts, appropriate fire extinguishing equipment shall be available to hand. Have a dry powder or CO₂ fire extinguisher adjacent to the charging area.

No ignition sources

No person carrying out work in relation to a **refrigerating system** which involves exposing any pipe work shall use any sources of ignition in such a manner that it can lead to the risk of fire or explosion. All possible ignition sources, including cigarette smoking, should be kept sufficiently far away from the site of installation, repairing, removing and disposal, during which refrigerant can possibly be released to the surrounding space. Prior to work taking place, the area around the equipment is to be surveyed to make sure that there are no flammable hazards or ignition risks. "No Smoking" signs shall be displayed.

Ventilated area

Ensure that the area is in the open or that it is adequately ventilated before breaking into the system or conducting any hot work. A degree of ventilation shall continue during the period that the work is carried out. The ventilation should safely disperse any released refrigerant and preferably expel it externally into the atmosphere.

Checks to the refrigerating equipment

Where electrical components are being changed, they shall be fit for the purpose and to the correct specification. At all times the manufacturer's maintenance and service guidelines shall be followed. If in doubt, consult the manufacturer's technical department for assistance.

*The following checks shall be applied to installations using **flammable refrigerants**:*

- the **refrigerant charge** is in accordance with the room size within which the refrigerant containing parts are installed;
- the ventilation machinery and outlets are operating adequately and are not obstructed;
- if an indirect refrigerating circuit is being used, the secondary circuit shall be checked for the presence of refrigerant;
- marking to the equipment continues to be visible and legible. Markings and signs that are illegible shall be corrected;
- refrigerating pipe or components are installed in a position where they are unlikely to be exposed to any substance which can corrode refrigerant containing components, unless the components are constructed of materials which are inherently resistant to being corroded or are suitably protected against being so corroded.

Checks to electrical devices

Repair and maintenance to electrical components shall include initial safety checks and component inspection procedures. If a fault exists that could compromise safety, then no electrical supply shall be connected to the circuit until it is satisfactorily dealt with. If the fault cannot be corrected immediately but it is necessary to continue operation, an adequate temporary solution shall be used. This shall be reported to the owner of the equipment so all parties are advised.

Initial safety checks shall include:

- that capacitors are discharged: this shall be done in a safe manner to avoid possibility of sparking;
- that no live electrical components and wiring are exposed while charging, recovering or purging the system;
- that there is continuity of earth bonding.

Repairs to sealed components and intrinsically safe components

⚠ WARNING

Sealed electrical components shall be replaced if it fails or is damaged.

Repair to intrinsically safe components

⚠ WARNING

Intrinsically safe components must be replaced if it fails or is damaged.

Wiring

Check that wiring will not be subject to wear, corrosion, excessive pressure, vibration, sharp edges or any other adverse environmental effects. The check shall also take into account the effects of aging or continual vibration from sources such as compressors or fans.

Detection of flammable refrigerants

Under no circumstances shall potential sources of ignition be used in the searching for or detection of refrigerant leaks. A halide torch (or any other detector using a naked flame) shall not be used.

The following leak detection methods are deemed acceptable for all refrigerant systems.

Electronic leak detectors may be used to detect refrigerant leaks but, in the case of **flammable refrigerants**, the sensitivity can be inadequate, or can need re-calibration. (Detection equipment shall be calibrated in a refrigerant-free area.) Ensure that the detector is not a potential source of ignition and is suitable for the refrigerant used. Leak detection equipment shall be set at a percentage of the **LFL** of the refrigerant and shall be calibrated to the refrigerant employed, and the appropriate percentage of gas (25 % maximum) is confirmed.

Leak detection fluids are also suitable for use with most refrigerants but the use of detergents containing chlorine shall be avoided as the chlorine can react with the refrigerant and corrode the copper pipe-work.

NOTE Examples of leak detection methods are

- bubble method,
- fluorescent agent method.

If a leak is suspected, all naked flames shall be removed/extinguished.

If a leakage of refrigerant is found which requires brazing, all of the refrigerant shall be recovered from the system, or isolated (by means of shut-off valves) in a part of the system remote from the leak. Removal of refrigerant shall be according to “Refrigerant removal and circuit evacuation”

Refrigerant removal and circuit evacuation

⚠ CAUTION

Oxygen free nitrogen (OFN) shall then be purged through the system both before and during the brazing process.

When breaking into the refrigerant circuit to make repairs - or for any other purpose - conventional procedures shall be used. However, for flammable refrigerants it is important that best practice be followed, since flammability is a consideration. The following procedure shall be adhered to:

- safely remove refrigerant following local and national regulations;
- evacuate;
- purge the circuit with inert gas;
- continuously flush with inert gas when using flame to open circuit;
- open the circuit.

The refrigerant charge shall be recovered into the correct recovery cylinders if venting is not allowed by local and national codes. For appliances containing flammable refrigerants, the system shall be purged with oxygen-free nitrogen to render the appliance safe for flammable refrigerants. This process might need to be repeated several times. Compressed air or oxygen shall not be used for purging refrigerant systems.

For appliances containing flammable refrigerants, refrigerants purging shall be achieved by breaking the vacuum in the system with oxygen-free nitrogen and continuing to fill until the working pressure is achieved, then venting to atmosphere, and finally pulling down to a vacuum (optional for A2L). This process shall be repeated until no refrigerant is within the system (optional for A2L). When the final oxygen-free nitrogen charge is used, the system shall be vented down to atmospheric pressure to enable work to take place.

The outlet for the vacuum pump shall not be close to any potential ignition sources, and ventilation shall be available.

⚠ CAUTION

An inert gas, specifically, is dry oxygen free nitrogen(OFN).

The system shall be “flushed” with OFN to render the unit safe. This process may need to be repeated several times.

⚠ CAUTION

This operation is absolutely vital if brazing operations on the pipework are to take place.

Charging procedures

In addition to conventional charging procedures, the following requirements shall be followed.

- Ensure that contamination of different refrigerants does not occur when using charging equipment. Hoses or lines shall be as short as possible to minimize the amount of refrigerant contained in them.
- Cylinders shall be kept in an appropriate position according to the instructions.
- Ensure that the refrigerating system is grounded prior to charging the system with refrigerant.
- Label the system when charging is complete (if not already labeled).
- Extreme care shall be taken not to overfill the refrigerating system.

Prior to recharging the system, it shall be pressure-tested with the appropriate purging gas. The system shall be leak-tested on completion of charging but prior to commissioning. A follow up leak test shall be carried out prior to leaving the site.

Decommissioning

Before carrying out this procedure, it is essential that the technician is completely familiar with the equipment and all its detail. It is recommended good practice that all refrigerants are recovered safely. Prior to the task being carried out, an oil and refrigerant sample shall be taken in case analysis is required prior to re-use of recovered refrigerant. It is essential that electrical power is available before the task is commenced.

- a) Become familiar with the equipment and its operation.
- b) Isolate system electrically.
- c) Before attempting the procedure, ensure that:
 - mechanical handling equipment is available, if required, for handling refrigerant cylinders;
 - all personal protective equipment is available and being used correctly;
 - the recovery process is supervised at all times by a competent person;
 - recovery equipment and cylinders conform to the appropriate standards.
- d) Pump down refrigerant system, if possible.
- e) If a vacuum is not possible, make a manifold so that refrigerant can be removed from various parts of the system.
- f) Make sure that the cylinder is situated on the scales before recovery takes place.
- g) Start the recovery machine and operate in accordance with instructions.
- h) Do not overfill cylinders (no more than 80 % volume liquid charge).
- i) Do not exceed the maximum working pressure of the cylinder, even temporarily.
- j) When the cylinders have been filled correctly and the process completed, make sure that the cylinders and the equipment are removed from site promptly and all isolation valves on the equipment are closed off.
- k) Recovered refrigerant shall not be charged into another refrigerating system unless it has been cleaned and checked.

Labelling

Equipment shall be labeled stating that it has been de-commissioned and emptied of refrigerant. The label shall be dated and signed. For appliances containing **flammable** refrigerants, ensure that there are labels on the equipment stating the equipment contains flammable refrigerant.

Recovery

When removing refrigerant from a system, either for servicing or decommissioning, it is required to follow good practice so that all refrigerants are removed safely.

When transferring refrigerant into cylinders, ensure that only appropriate refrigerant recovery cylinders are employed. Ensure that the correct number of cylinders for holding the total system charge is available. All cylinders to be used are designated for the recovered refrigerant and labeled for that refrigerant (i.e. special cylinders for the recovery of refrigerant). Cylinders shall be complete with pressure-relief valve and associated shut-off valves in good working order. Empty recovery cylinders are evacuated and, if possible, cooled before recovery occurs.

The recovery equipment shall be in good working order with a set of instructions concerning the equipment that is at hand and shall be suitable for the recovery of the **flammable refrigerant**. If in doubt, the manufacturer should be consulted. In addition, a set of calibrated weighing scales shall be available and in good working order. Hoses shall be complete with leak-free disconnect couplings and in good condition.

The recovered refrigerant shall be processed according to local legislation in the correct recovery cylinder, and the relevant waste transfer note arranged. Do not mix refrigerants in recovery units and especially not in cylinders.

If compressors or compressor oils are to be removed, ensure that they have been evacuated to an acceptable level to make certain that **flammable refrigerant** does not remain within the lubricant. The compressor body shall not be heated by an open flame or other ignition sources to accelerate this process. When oil is drained from a system, it shall be carried out safely.

⚠ CAUTION

Be sure the heat pump is grounded. In order to avoid electric shock, make sure that the unit is grounded and that the ground wire is not connected to a gas or water pipe, lightning conductor or telephone ground wire.

Do not operate the heat pump with a wet hands. An electric shock may happen.

Do not operate the heat pump when using a room fumigation-type insecticide. Failure to observe this precaution could cause the chemicals to become deposited in the unit, which could endanger the health of those who are hypersensitive to chemicals. It may also cause the refrigerant sensor to alarm.

To avoid oxygen deficiency, ventilate the room sufficiently if equipment with a burner is used together with the heat pump.

Arrange the drain hose to ensure smooth drainage. Incomplete drainage may cause wetting of the building, furniture, etc.

Never touch the internal parts of the controller. Do not remove the front panel. Some parts inside are dangerous to touch, and machine troubles may occur.

Attention is drawn to the fact that additional transportation regulations may exist with respect to equipment containing flammable gas. The maximum number of pieces of equipment or the configuration of the equipment permitted to be transported together will be determined by the applicable transport regulations.

Signs for similar appliances used in a work area are generally addressed by local regulations and give the minimum requirements for the provision of safety and/or health signs for a work location.

Storage package protection should be constructed such a way that mechanical damage to the equipment inside the package will not cause a leak of the REFRIGERANT CHARGE.

The maximum number of pieces of equipment permitted to be stored together will be determined by local regulations.

All required signs are to be maintained and employers should ensure that employees receive suitable and sufficient instruction and training on the meaning of appropriate safety signs and the actions that need to be taken in connection with these signs.

The effectiveness of signs should not be diminished by too many signs being placed together.

Any pictograms used should be as simple as possible and contain only essential details.

The storage of the appliance should be in accordance with the applicable regulations or instructions, whichever is more stringent.

Do not place appliances which produce open flame in places exposed to the air flow from the unit or under the indoor unit. It may cause incomplete combustion or deformation of the unit due to the heat.

Do not install the heat pump in a location where flammable gas may leak out. If the gas leaks out and stays around the heat pump, a fire may break out.

⚠ WARNING

The appliance uses R32 refrigerant.



⚠ WARNING

These instructions are exclusively intended for qualified contractors and authorized installers.

Work on the refrigerant circuit with mild flammable refrigerant in safety group A2L may only be carried out by authorized heating contractors. These heating contractors must be trained in accordance with UL 60335-2-40, Section HH. The certificate of competence from an industry accredited body is required.

Work on electrical equipment may only be carried out by a qualified electrician.

Before initial commissioning, all safety – related points must be checked by the particular certified heating contractors. The system must be commissioned by the system installer or a qualified person authorized by the installer.

Special requirements for R32

⚠ WARNING

- Do NOT have refrigerant leakage and open flame.
- Be aware that the R32 refrigerant does NOT contain an odor.

⚠ WARNING

- Do NOT re-use joints which have been used already.
- Joints made in installation between parts of refrigerant system shall be accessible for maintenance purposes.

⚠ WARNING

Make sure installation, servicing, maintenance and repair comply with instructions and with applicable legislation (for example national gas regulation) and are executed only by authorized persons.

⚠ CAUTION

- Pipework should be protected from physical damage.
- Installation of pipework shall be kept to a minimum length.

IMPORTANT INFORMATION FOR THE REFRIGERANT

This product has the fluorinated gas, it is forbidden to release to air.

Refrigerant type: R32; GWP: 675.

GWP=Global Warming Potential

Model	Factory charged refrigerant volume in the unit	
	Refrigerant / lb(kg)	Tonnes CO ₂ equivalent
12/14/16 kW	4.04(1.835)	1.24

⚠ CAUTION

- Frequency of Refrigerant Leakage Checks
 - Equipment that contains less than 6.61 lb(3 kg) of fluorinated greenhouse gases or hermetically sealed equipment, which is labeled accordingly and contains less than 13.23 lb(6 kg) of fluorinated greenhouse gases shall not be subject to leak checks.
 - For unit that contains fluorinated greenhouse gases in quantities of 5 tonnes of CO₂ equivalent or more, but of less than 50 tonnes of CO₂ equivalent, at least every 12 months, or where a leakage detection system is installed, at least every 24 months.
 - Only certified person is allowed to do installation, operation and maintenance.

2 ACCESSORIES

2.1 Overview of the unit

2.1.1 Disassembling the unit

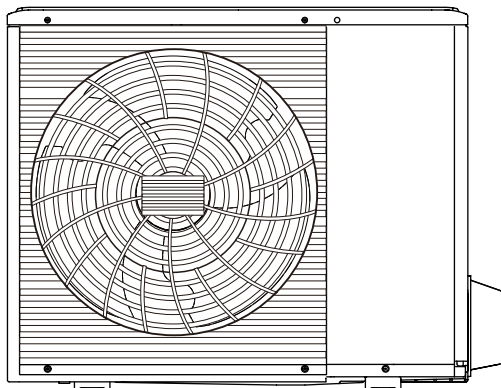

Door 1 To access to the compressor and electrical parts.

⚠ WARNING

- Cut off all power supply— i.e. unit power supply and backup heater and domestic hot water tank power supply (if applicable) — before removing doors 1.
- Parts inside the unit may be hot.

2.1.2 Electronic control box

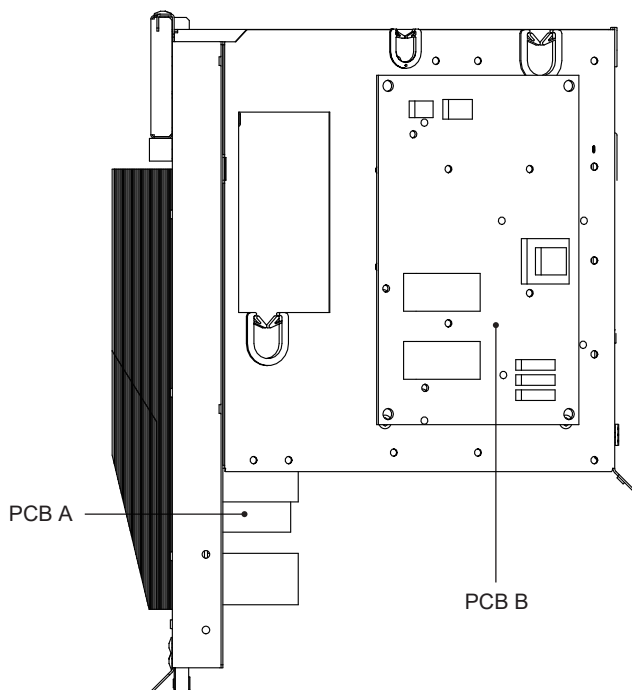

💡 NOTICE

The picture is for reference only, please refer to the actual product.

2.1.3 12/14/16 kW 1-phase units

1) PCB A, Inverter module

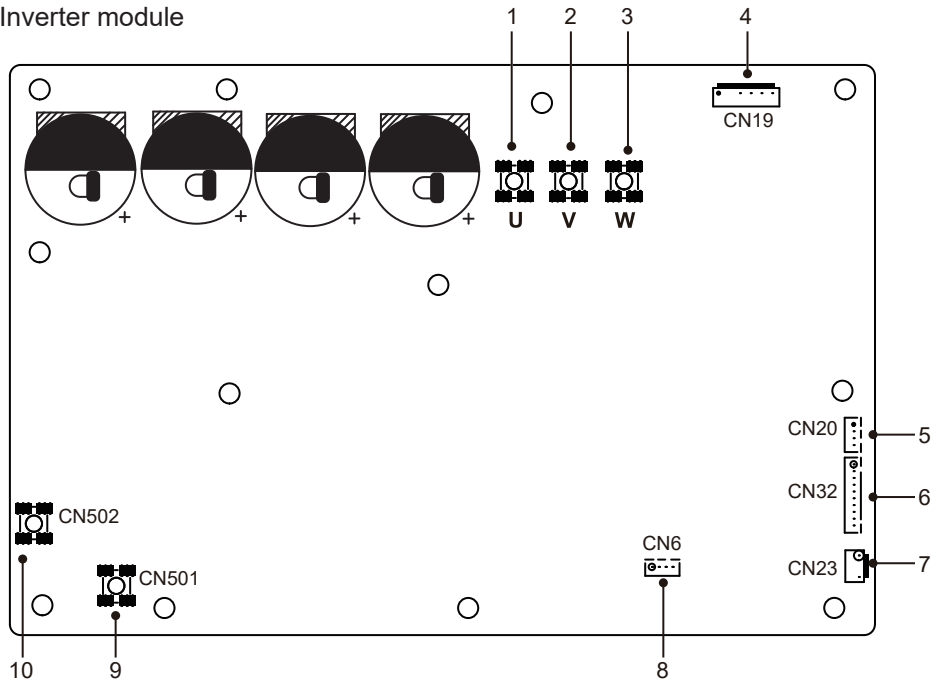

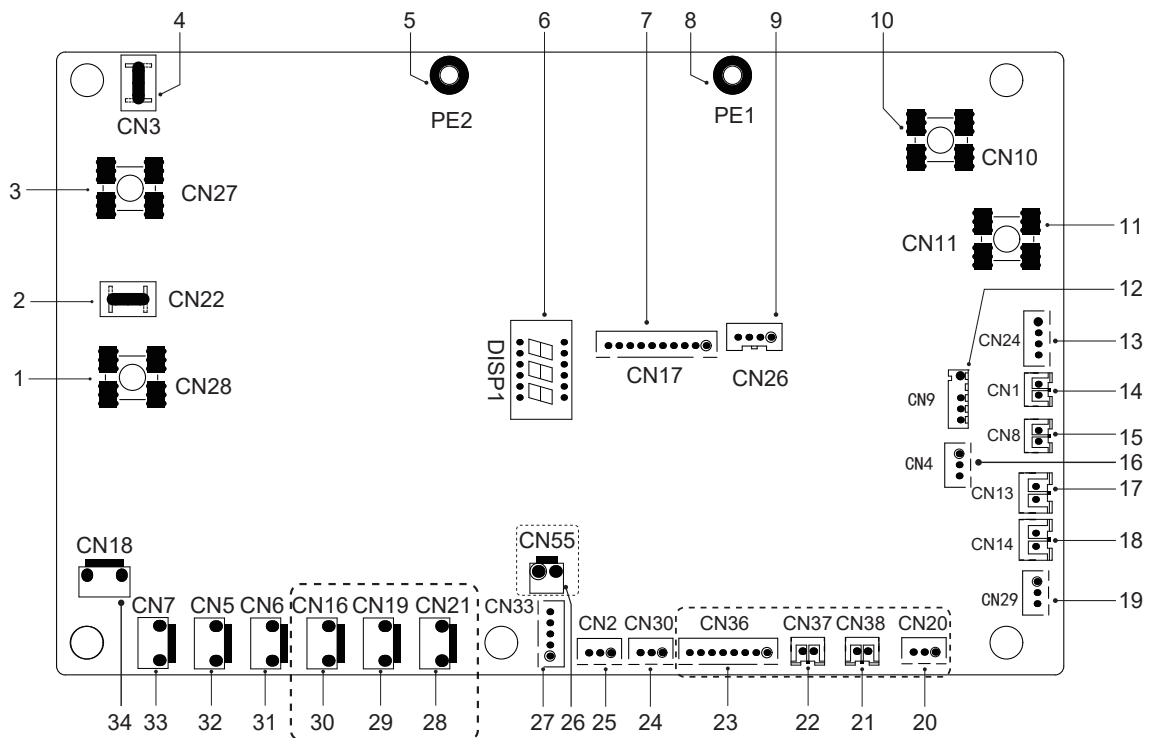

Code	Assembly unit	Code	Assembly unit
1	Compressor connection port U	6	Port for communication with PCB B(CN32)
2	Compressor connection port V	7	Port for high pressure switch (CN23)
3	Compressor connection port W	8	Reserved(CN6)
4	Port for fan(CN19)	9	Input port L for rectifier bridge(CN501)
5	Output port for + 12 V/9 V(CN20)	10	Input port N for rectifier bridge(CN502)

2) PCB B, Main control board



Code	Assembly unit	Code	Assembly unit
1	Output port L to PCB A(CN28)	18	Port for low pressure switch (CN14)
2	Reserved(CN22)	19	Port for communication with hydro-box control board (CN29)
3	Output port N to PCB A(CN27)	20	Reserved(CN20)
4	Reserved(CN3)	21	Reserved(CN38)
5	Port for earth wire(PE2)	22	Reserved(CN37)
6	Digital display(DSP1)	23	Reserved(CN36)
7	Port for communication with PCB A(CN17)	24	Port for communication(reserved,CN30)
8	Port for earth wire(PE1)	25	Port for communication(reserved,CN2)
9	Reserved(CN26)	26	Reserved(CN55)
10	Input port for neutral wire(CN10)	27	Port for electrical expansion valve(CN33)
11	Input port for live wire(CN11)	28	Reserved(CN21)
12	Port for outdoor ambient temp. sensor and condenser temp.sensor(CN9)	29	Reserved(CN19)
13	Input port for +12 V/9 V(CN24)	30	Port for chassis electrical heating tape(CN16) (optional)
14	Port for suction temp.sensor(CN1)	31	Port for 4-way valve(CN6)
15	Port for discharge temp.sensor(CN8)	32	Port for SV6 valve(CN5)
16	Port for pressure sensor(CN4)	33	Port for compressor electric heating tape 1(CN7)
17	Port for high pressure switch (CN13)	34	Port for compressor electric heating tape 2(CN18)

2.2 Accessories supplied with the unit

Installation Fittings		
Name	Shape	Quantity
Outdoor unit installation & owners manual (this book)		1
Water outlet connection pipe assembly		1

3 BEFORE INSTALLATION

- **Before installation**

Be sure to confirm the model name and the serial number of the unit.

- **Handling**

1. Handle the unit using the sling to the left and the right .Pull up both sides of the sling at the same time to prevent disconnection of the sling from the unit.

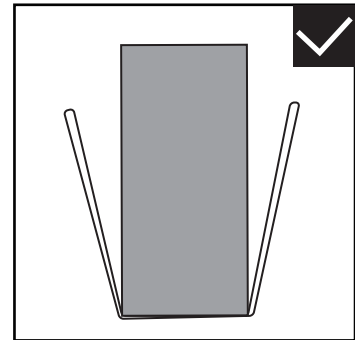
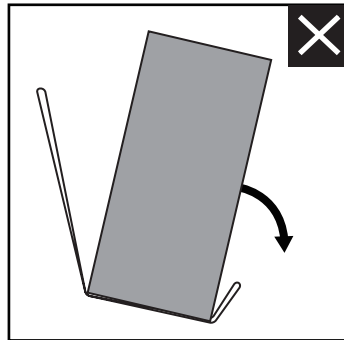
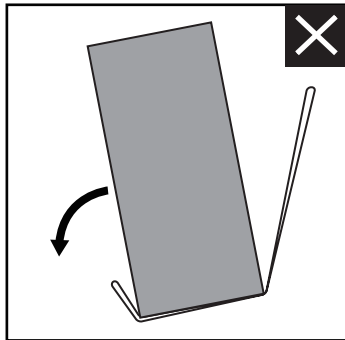
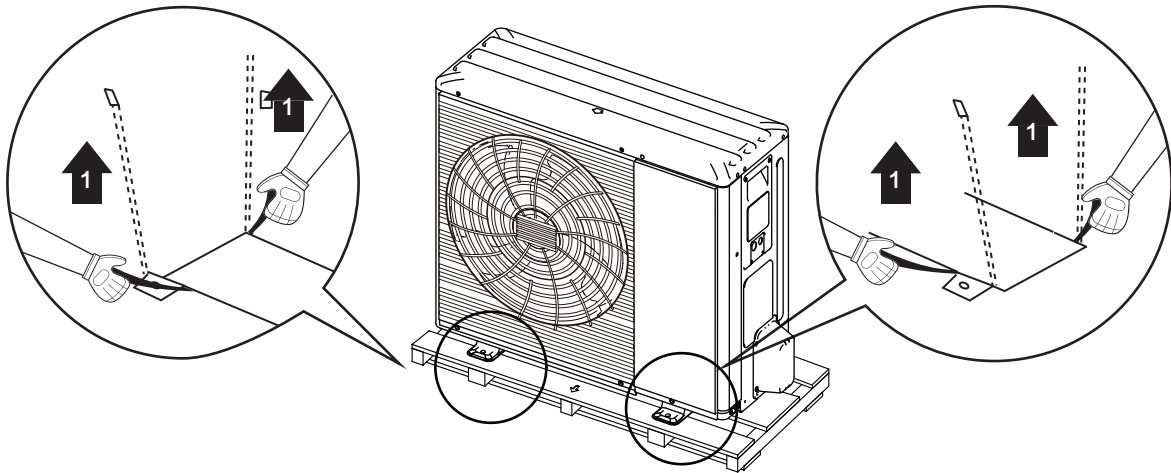

2. While handling the unit

- keep both sides of the sling level.
- keep your back straight

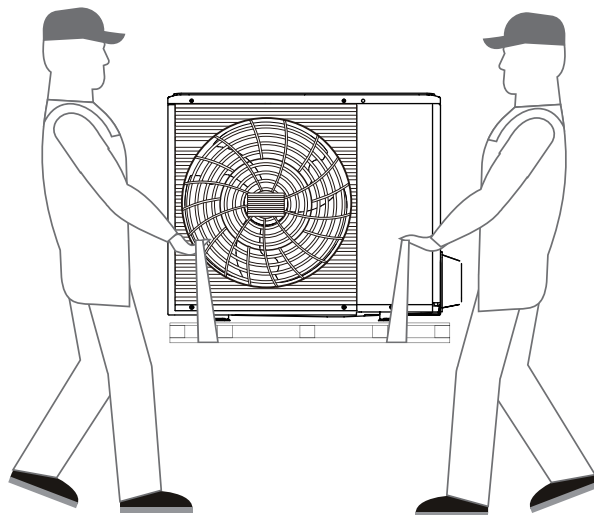

3. After mounting the unit,remove the sling from the unit by pulling 1 side of the sling.

⚠ CAUTION

- To avoid injury, do not touch the air inlet and aluminum fins of the unit.
- Do not use the grips in the fan grills to avoid damage.
- The unit is top heavy! Prevent the unit from falling due to improper inclination during handling.

4 INSTALLATION SITE

⚠ WARNING

- Be sure to adopt adequate measures to prevent the unit from being used as a shelter by small animals. Small animals making contact with electrical parts can cause malfunction, smoke or fire. Please instruct the customer to keep the area around the unit clean.

⚠ WARNING

The outdoor unit shall be located in a well-ventilated location other than the occupied space, such as in the open air.

For installation of the indoor unit, refer to the corresponding installation and operation manual. If an indoor unit is installed in an unventilated area, the area shall be so constructed that should any refrigerant leak, it will not stagnate so as to create a fire or explosion hazard.

⚠ WARNING

The appliance shall be stored so as to prevent mechanical damage from occurring.

- Select an installation site where the following conditions are satisfied and one that meets with your customer's approval.
 - Places that are well-ventilated.
 - Places where the unit does not disturb next-door neighbors.
 - Safe places which can bear the unit's weight and vibration and where the unit can be installed at an even level.
 - Places where there is no possibility of flammable gas or product leak.
 - The equipment is not intended for use in a potentially explosive atmosphere.
 - Places where servicing space can be well ensured.
 - Places where the units' piping and wiring lengths come within the allowable ranges.
 - Places where water leaking from the unit cannot cause damage to the location (e.g. in case of a blocked drain pipe).
 - Places where rain can be avoided as much as possible.
 - Do not install the unit in places often used as a work space. In case of construction work (e.g. grinding etc.) where a lot of dust is created, the unit must be covered.
 - Do not place any object or equipment on top of the unit (top plate)
 - Do not climb, sit or stand on top of the unit.
 - Be sure that sufficient precautions are taken in case of refrigerant leakage according to relevant local laws and regulations.- Don't install the unit near the sea or where there is corrosion gas.
- When installing the unit in a place exposed to strong wind, pay special attention to the following.
- Strong winds of 10 mph or more blowing against the unit's air outlet causes a short circuit (suction of discharge air), and this may have the following consequences:
 - Deterioration of the operational capacity.
 - Frequent frost acceleration in heating operation.
 - Disruption of operation due to rise of high pressure.
 - Motor burnout.
 - When a strong wind blows continuously on the front of the unit, the fan can start rotating very fast until it breaks.

In normal condition, refer to the figures below for installation of the unit:

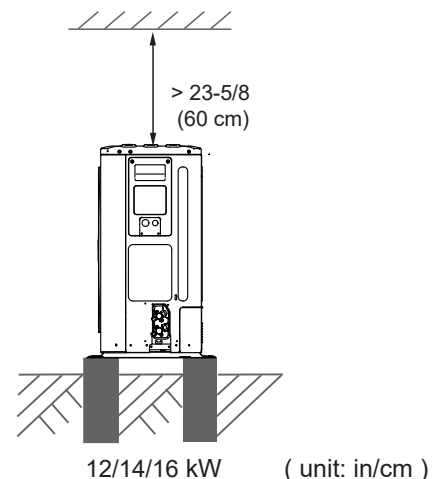
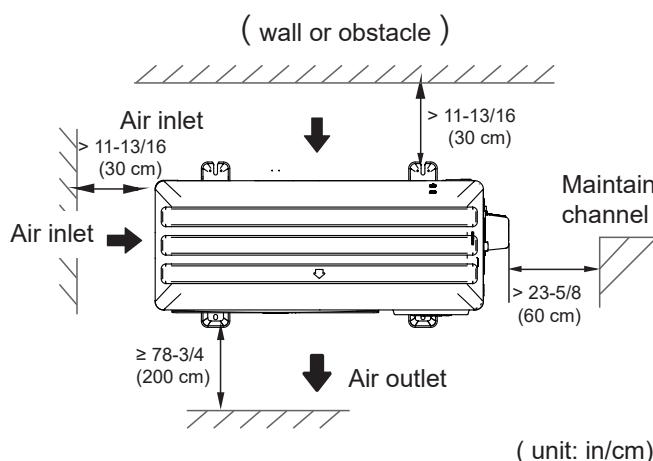

NOTICE

- Make sure there is enough space to do the installation. Set the outlet side at a right angle to the direction of the wind.
- Prepare a water drainage channel around the foundation, to drain waste water from around the unit.
- If water does not easily drain from the unit, mount the unit on a foundation of concrete blocks, etc. (the height of the foundation should be about 3-15/16 in(100 mm) .(in Fig:6-3)
- When installing the unit in a place frequently exposed to snow, pay special attention to elevate the foundation as high as possible.
- If you install the unit on a building frame, please install a waterproof plate (field supply) (about 3-15/16 in(100 mm), on the underside of the unit) in order to avoid drain water dripping. (See the picture in the right).



4.1 Selecting a location in cold climates

Refer to "Handling" in section "3 Before installation"

NOTICE

When operating the unit in cold climates, be sure to follow the instructions described below.

- Never install the unit at a site where the suction side may be exposed directly to wind.
- It is recommended that the unit be placed with the rear side against the wall.
- Install a high pedestal or wall mount the unit to keep a proper clearance (at least 4 inches/101.6mm) above snow line.
- In heavy snowfall areas, it is very important to select an installation site where the snow will not affect the unit. If lateral snowfall is possible, make sure that the heat exchanger coil is not affected by the snow (if necessary construct a lateral canopy).

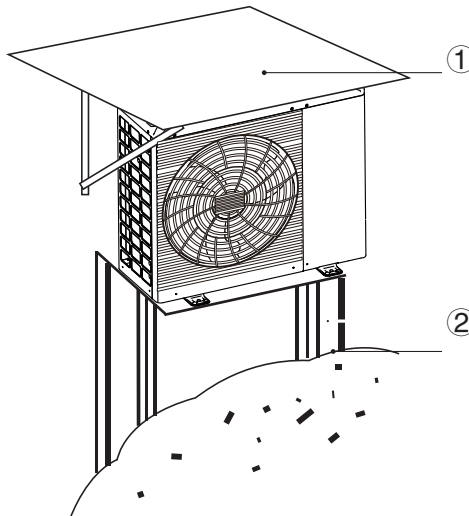

- ① Construct a large canopy.
- ② Construct a pedestal.

Install the unit high enough off the ground to prevent it from being buried in snow.

4.2 Prevent sunshine

As the outdoor temperature is measured via the outdoor unit air thermistor, make sure to install the outdoor unit in the shade or a canopy should be constructed to avoid direct sunlight, so that it is not influenced by the sun's heat, otherwise damage may be possible to the unit.

WARNING

For uncovered installations: 1) Provide construction that will prevent rain and snow from hitting the heat exchanger, resulting in poor heating capacity of the unit due to water/snow accumulation that can potentially freeze the heat exchanger; 2) Provide construction that will prevent the outdoor unit air thermistor from being exposed to direct sunlight that could result in boot failure; 3) Provide construction that will prevent freezing rain from hitting the heat exchanger.

5 UNIT INSTALLATION

5.1 Dimensions

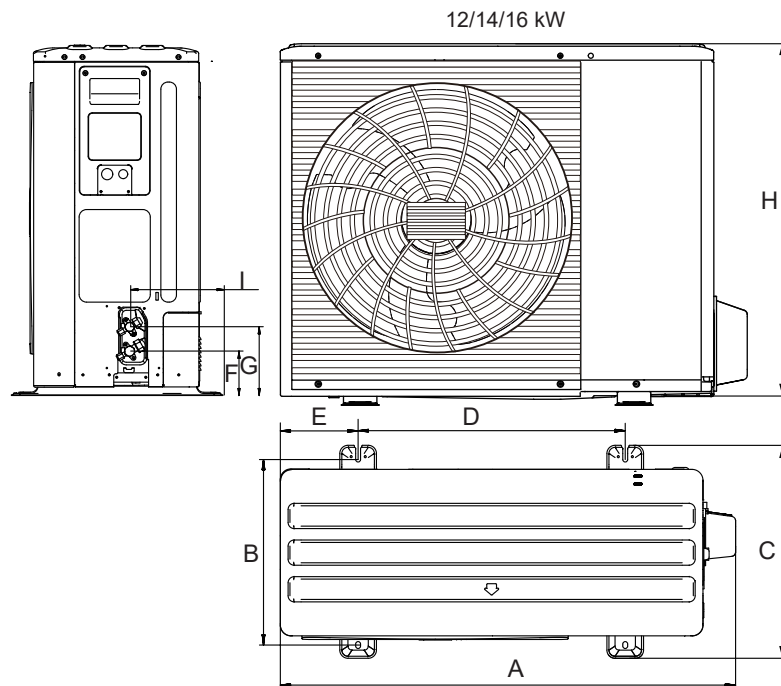

Fig: 6-1

(unit: in/mm)

Model	A	B	C	D	E	F	G	H	I
12/14/16 kW	44	17-15/16	20-9/16	15-13/16	7-1/2	4-5/16	6-11/16	34-1/16	9-1/16
	1118	456	523	402	191	110	170	865	230

5.2 Installation requirements

- Check the strength and level of the installation ground so that the unit may not cause any vibrations or noise during the operation.
- In accordance with the foundation drawing in the figure, fix the unit securely by means of foundation bolts. (Prepare four sets each of 3/8"(9.53 mm) Expansion bolts, nuts and washers which are readily available in the market.)
- Screw in the foundation bolts until their length is 13/16 in (20 mm) from the foundation surface.

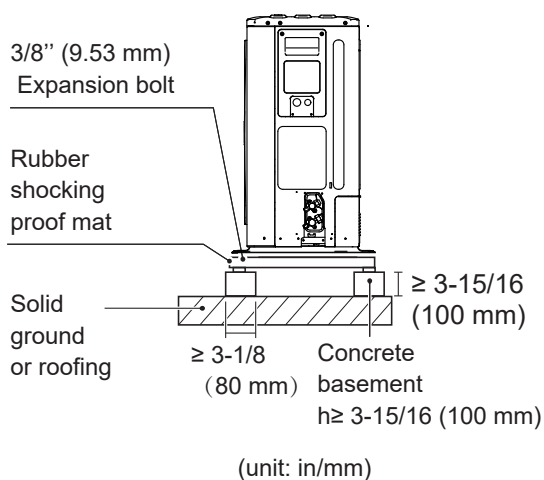

Fig: 6-2

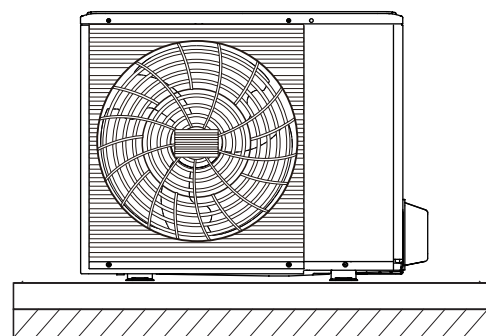
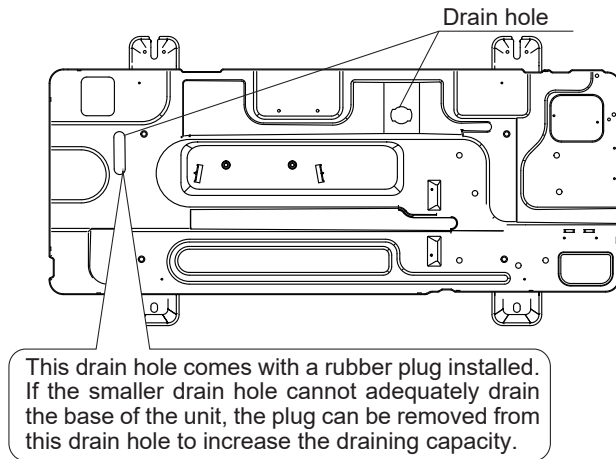

Fig: 6-3

⚠ WARNING

Ensure that apparatus is mounted securely.

5.3 Drain hole position



12/14/16 kW

Fig: 6-4

⚠ CAUTION

- If the drain holes cannot adequately drain the base of the unit due to colder weather, an electrical heating tape should be installed.
- It is suggested to site the unit with the base electric heater.

5.4 Installation space requirements

5.4.1 In case of stacked installation

1) In case obstacles exist in front of the outlet side.

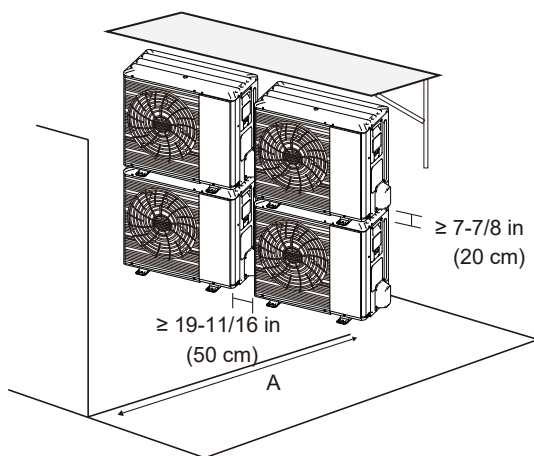

2) In case obstacles exist in front of the air inlet.

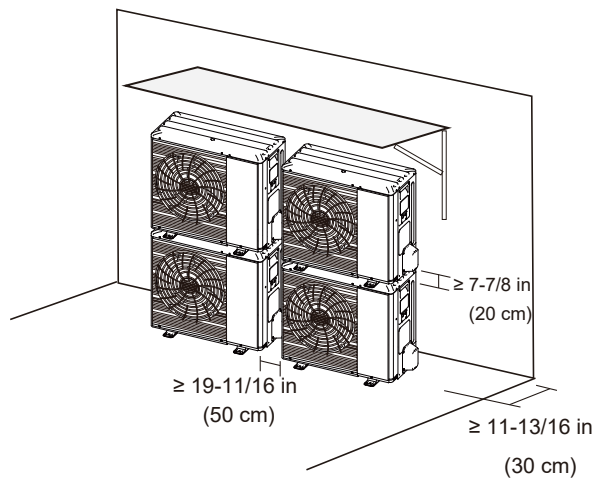

Fig: 6-5

Unit	A
12/14/16 kW	≥ 78-3/4 in (2 m)

💡 NOTICE

It's necessary to install the water outlet connection pipe assembly if the unit is mounted on the top of each other, preventing condensate flow to the heat exchanger.

5.4.2 In case of multiple-row installation

1) In case of installing one unit per row.

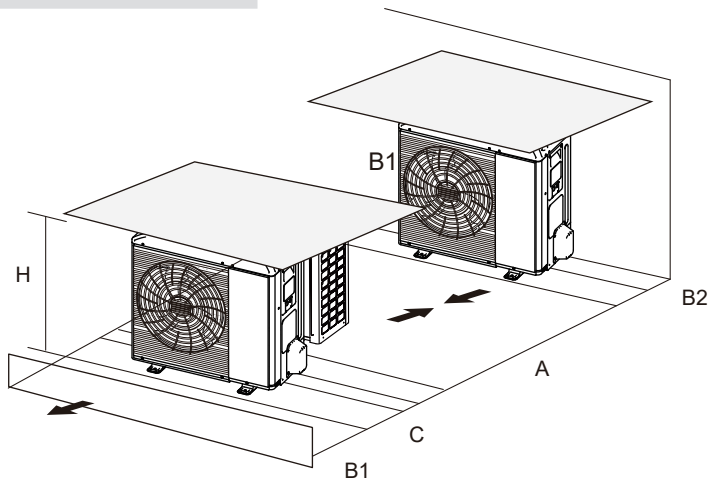

Fig: 6-6

Unit	A	B1	B2	C
12/14/16 kW	≥ 118-1/8 in	≥ 78-3/4 in	≥ 5-15/16 in	≥ 23-5/8 in
	≥ 3 m	≥ 2 m	≥ 0.15 m	≥ 0.6 m

2) In case of installing multiple units in lateral connection per row.

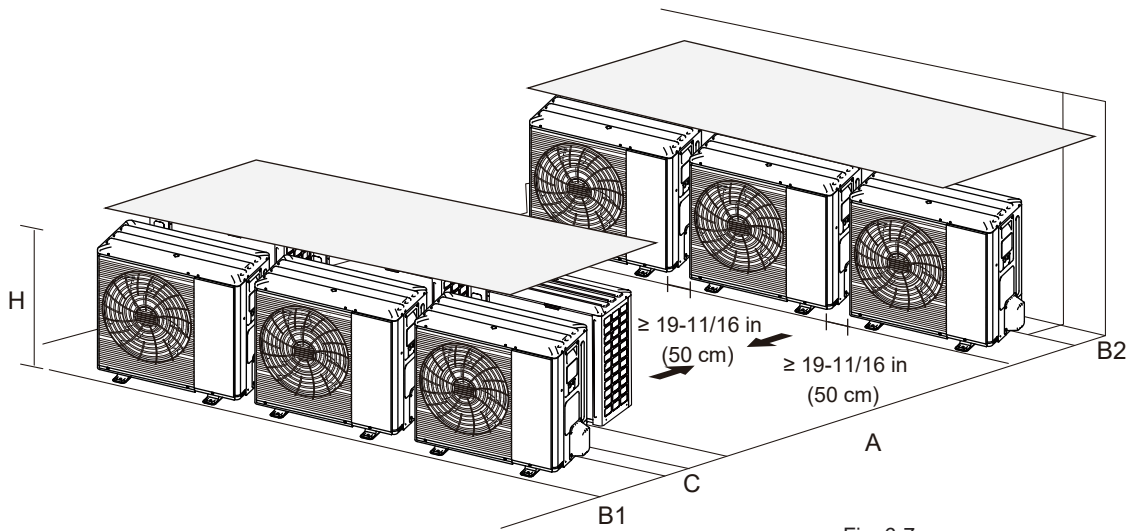

Fig: 6-7

Unit	A	B1	B2	C
12/14/16 kW	≥ 118-1/8 in	≥ 78-3/4 in	≥ 5-15/16 in	≥ 23-5/8 in
	≥ 3 m	≥ 2 m	≥ 0.15 m	≥ 0.6 m

6 PIPING INSTALLATION

6.1 Refrigerant piping

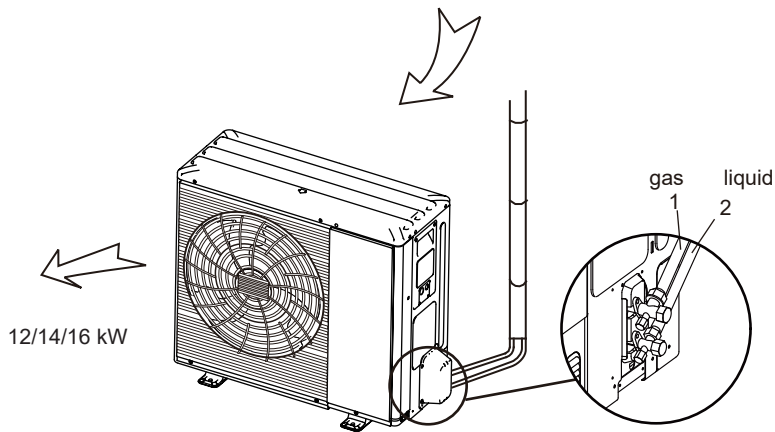

Fig.7-1

⚠ CAUTION

- To prevent the refrigerant piping from oxidizing inside when welding, it is necessary to charge nitrogen, or oxide will clog the circulation system.
- If using existing refrigerant lines, make certain that all joints are brazed, not soldered.
- After the installation of the refrigerant pipe is completed, the two shut-off valves should be wrapped with insulation cotton, and then the protective shell of the valve body should be installed.

⚠ WARNING

The pipe-work including piping material, pipe routing, and installation shall include protection from physical damage in operation and service, and be in compliance with national and local codes and standards, such as ASHRAE 15, ASHRAE 15.2, IAPMO Uniform Mechanical Code, ICC International Mechanical Code. Inspection prior to being covered or enclosed, or CSA B52. All field joints shall be accessible for inspection prior to being covered or enclosed.

⚠ WARNING

Pipe work and installation shall be in compliance with national codes ASHRAE 15.

The installation of pipe-work shall be kept to a minimum.

All joints made in the installation between parts of the refrigerating system, with at least one part charged, shall be made in accordance with the following:

- A brazed, welded, or mechanical connection shall be made before opening the valves to permit refrigerant to flow between the refrigerating system parts. A vacuum valve shall be provided to evacuate the interconnecting pipe or any uncharged refrigerating system part.
- Mechanical connectors used indoors shall comply with ISO 14903. When mechanical connectors are reused indoors, sealing parts shall be renewed. When flared joints are reused indoors, the flare part shall be refabricated.
- Refrigerant tubing shall be protected or enclosed to avoid damage.
- Flexible refrigerant connectors (such as connecting lines between the indoor and outdoor unit) that may be displaced during normal operation shall be protected against mechanical damage.

Compliance is checked according to the installation instructions and a trial installation, if necessary.

Field-made refrigerant joints indoors shall be tightness tested. The test method shall have a sensitivity of 0.012 lbs per year of refrigerant or better under a pressure of at least 0.25 times the maximum allowable pressure. No leak shall be detected.

For installations with field applied joints that are exposed in the occupied space, these joints shall be at least one of the following:

- Mechanical joints in compliance with ISO 14903 or UL 207 (U.S. only).
- Welded or brazed joints.
- Joints in enclosures that vent to the unit or to the outside.

Compliance is checked by inspection and tests.

6.2 Leakage detection

⚠ WARNING

After completion of field piping for split systems, the field pipework shall be pressure tested with an inert gas and then vacuum tested prior to refrigerant charging, according to the following requirements.

The minimum test pressure for the low side of the system shall be the low side design pressure and the minimum test pressure for the high side of the system shall be the high side design pressure, unless the high side of the system, cannot be isolated from the low side of the system in which case the entire system shall be pressure tested to the low side design pressure.

Field-made refrigerant joints indoors shall be tightness tested. The test method shall have a sensitivity of 5 grams per year of refrigerant or better under a pressure of at least 0.25 times the maximum allowable pressure. No leak shall be detected.

Use soap water or leakage detector to check every joint whether leak or not (Refer to Fig.7-2).Note:

A is high pressure side stop valve

B is low pressure side stop valve

C and D is connecting pipes interface of indoor and outdoor units

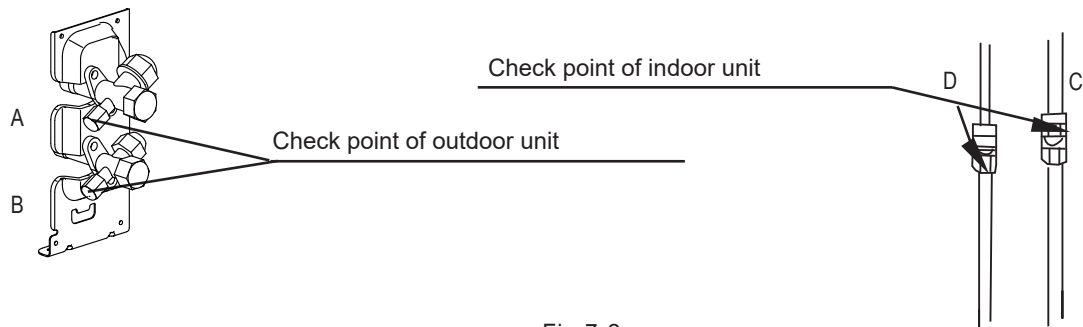

Fig.7-2

6.3 Heat insulation

In order to avoid the release of cold or heat from the connecting pipeline to the external environment during the operation of the equipment, please take effective insulation measures for the gas pipe and liquid pipe separately

- 1) The gas side pipe should use closed cell foamed insulation material, which the fire-retardant is B1 grade and the heat resistance over 248 °F(120 °C).
- 2) When the external diameter of copper pipes $\leq 1/2$ in(12.7 mm), the thickness of the insulating layer at least more than 9/16 in(15 mm); When the external diameter of copper pipe $\geq 5/8$ in(15.88 mm), the thickness of the insulating layer at least more than 13/16 in(20 mm).
- 3) Please insulate the connecting pipes between the indoor unit and the outdoor unit without gaps using insulation materials.

6.4 Connecting method

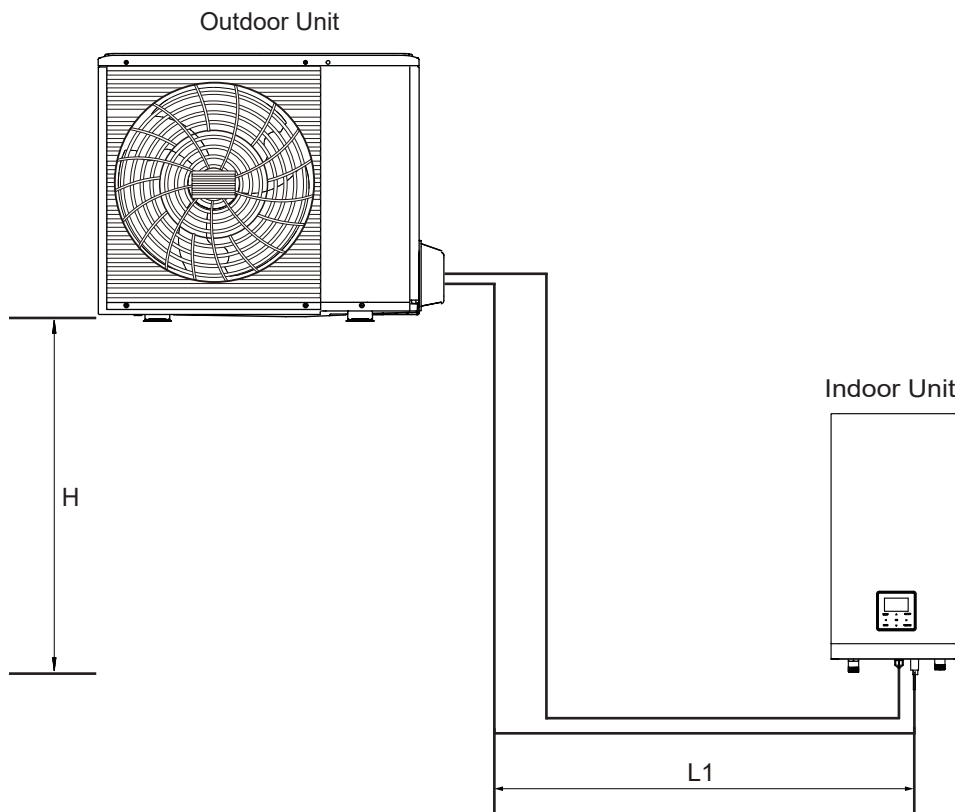

Figure 7-3

Models	12/14/16 kW
Max. piping length (H+L1)	98 ft (30 m)
Max difference in height (H)	65 ft (20 m)

1) Size of pipes of Gas side and Liquid side

MODEL	Refrigerant	Gas side/Liquid side
12/14/16 kW	R32	5/8 in, 3/8 in (15.88 mm, 5.53 mm)

2) Connection method

	Gas side	Liquid side
12/14/16 kW outdoor unit	Flaring	Flaring
Indoor unit	Flaring	Flaring

6.5 Remove dirt or water in the pipes

- 1) Make sure there is no debris or water in piping before connecting to outdoor and indoor units.
- 2) Wash the pipes with high pressure nitrogen, never use refrigerant of outdoor unit.

6.6 Airtight testing

Charge pressured nitrogen after connecting indoor/outdoor unit pipes to do airtight testing.

⚠ CAUTION

Pressured nitrogen [623.5 psi (43 bar) for R32] should be used in the airtight testing.
Tighten high/low pressure valves before charging pressured nitrogen.
Charge pressure nitrogen from the connector on the pressure valves.
The airtight testing should never use any oxygen, flammable gas or poisonous gas.

6.7 Air purge with vacuum pump

- 1) Using vacuum pump to do the vacuum, never using refrigerant to expel the air.
- 2) Vacuuming should be done from liquid side .

6.8 Refrigerant amount to be added

Calculate the added refrigerant according to the diameter and the length of the liquid side pipe of the outdoor unit/indoor unit connection. If the length of the liquid side pipe is less than 49.2 ft (15 m), there is no need to add more refrigerant. When the piping length is greater than 49.2 ft (15 m), calculate the amount of additional refrigerant required according to the formula in the table below.

Refrigerant to be added	Model	Total liquid pipe length L(ft/m)	
		≤ 49.2 ft (15 m)	> 49.2 ft (15 m)
Total additional refrigerant	12/14/16	0 lb	$m_{add}(lb)=0.0256 \times L(ft) - 1.257$ $m_{add}(g)=38 \times L(m) - 15$

L: the length of the liquid side pipe of the outdoor unit/indoor unit connection;
 m_{add} : Amount of refrigerant to be added.

7 WIRING

⚠ WARNING

- In the U.S.A., wiring must conform with current local codes and the current National Electric Code (NEC). In Canada, wiring must conform with current local codes and the current Canadian Electrical Code (CEC)
- A main switch or other means of disconnection, having a contact separation in all poles, must be incorporated in the fixed wiring in accordance with relevant local laws and regulations. Switch off the power supply before making any connections. Use only copper wires. Never squeeze bundled cables and make sure they do not come in contact with the piping and sharp edges. Make sure no external pressure is applied to the terminal connections. All field wiring and components must be installed by a licensed electrician and must comply with relevant local laws and regulations.
- The field wiring must be carried out in accordance with the wiring diagram supplied with the unit and the instructions given below.
- Be sure to use a dedicated power supply. Never use a power supply shared by another appliance.
- Be sure to establish a earth. Do not earth the unit to a utility pipe, surge protector, or telephone earth. Incomplete earthing may cause electrical shock.
- Be sure to install a earth fault circuit interrupter (30 mA). Failure to do so may cause electrical shock.
- Be sure to install the required fuses or circuit breakers.

7.1 Precautions on electrical wiring work

- Fix cables so that cables do not make contact with the pipes (especially on the high pressure side).
- Secure the electrical wiring with cable ties as shown in figure so that it does not come in contact with the piping, particularly on the high-pressure side.
- Make sure no external pressure is applied to the terminal connectors.
- When installing the earth fault circuit interrupter make sure that it is compatible with the inverter (resistant to high frequency electrical noise) to avoid unnecessary opening of the earth fault circuit interrupter.

💡 NOTICE

The earth fault circuit interrupter must be a high-speed type breaker of 30 mA (< 0.1 s).

- This unit is equipped with an inverter. Installing a phase advancing capacitor not only will reduce the power factor improvement effect, but also may cause abnormal heating of the capacitor due to high-frequency waves. Never install a phase advancing capacitor as it could lead to an accident.

7.2 Precautions on wiring of power supply

- Use a round crimp-style terminal for connection to the power supply terminal board. In case it cannot be used due to unavoidable reasons, be sure to observe the following instructions.
- Do not connect different gauge wires to the same power supply terminal. (Loose connections may cause overheating.)
- When connecting wires of the same gauge, connect them according to the figure below.

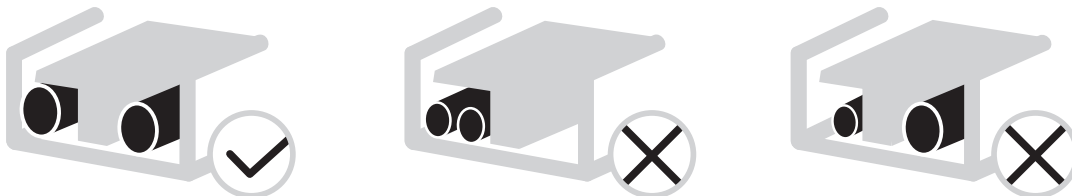

- Use the correct screwdriver to tighten the terminal screws. Small screwdrivers can damage the screw head and prevent appropriate tightening.
- Over-tightening the terminal screws can damage the screws.
- Attach a earth fault circuit interrupter and fuse to the power supply line.
- In wiring, make certain that prescribed wires are used, carry out complete connections, and fix the wires so that outside force cannot affect the terminals.

7.3 Safety device requirement

1. Select the wire diameters (minimum value) individually for unit based on the table 7-1 and table 7-2.
2. Select circuit breaker that having a contact separation in all poles not less than 0.118 inch providing full disconnection, where MFA is used to select the current circuit breakers and residual current operation breakers.

Table 7-1

Model	12kW	14kW	16kW
Min. Circuit Amps.(MCA) (A)	32	33	34
Min. Wiring size (AWG)	8		

- Stated values are maximum values (see electrical data for exact values).

Table 7-2

Model	Outdoor Unit				Power Current		Compressor	Fan motors	
	Voltage (V)	Hz	Min. (V)	Max. (V)	MCA (A)	MFA (A)	RLA (A)	KW	FLA (A)
12kW	208/230	60	198	264	32	50	24.5	0.17	1.3
14kW	208/230	60	198	264	33	50	25	0.17	1.3
16kW	208/230	60	198	264	34	50	26	0.17	1.3

⚡ NOTICE

MCA :Min. Circuit Amps. (A)
MFA : Max. Fuse Amps. (A)
RLA :Rated Load Amps.(A)
KW : Rated Motor Output
FLA : Full Load Amps. (A)

7.4 Remove the switch box cover

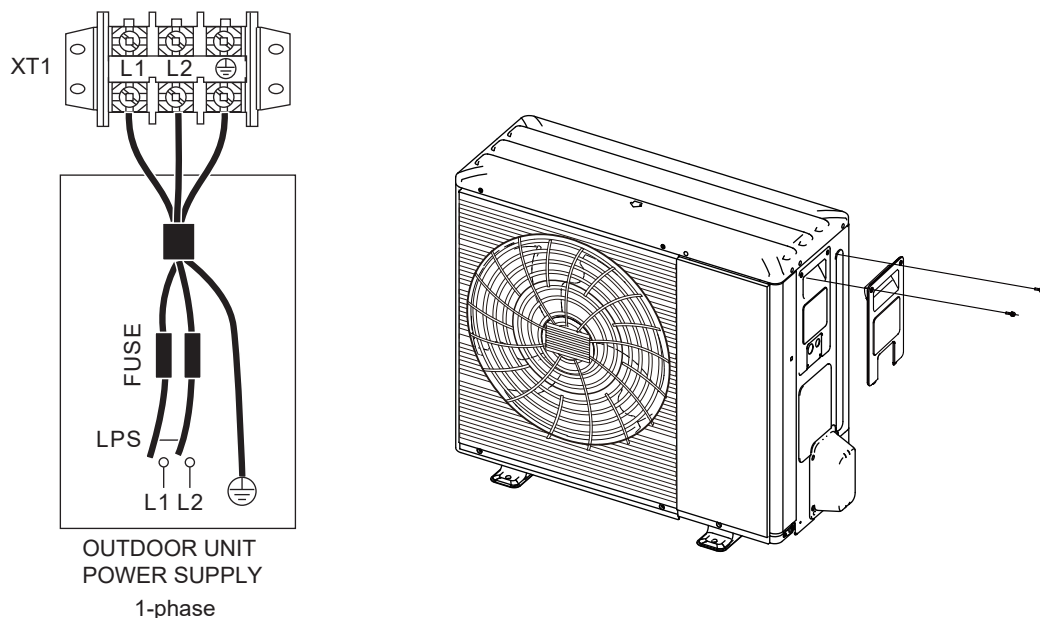

⚡ NOTICE

The earth fault circuit interrupter must be a high-speed type breaker of 30 mA (< 0.1 s).

Please use 3-core shielded wire.

To avoid electric shock and rainwater entering the inside of the machine through the communication cable holes, the communication cables of the internal and external machines need to go through conduits.

7.5 To finish the outdoor unit installation

insulate and fix the refrigerant piping and interconnection cable as follows:

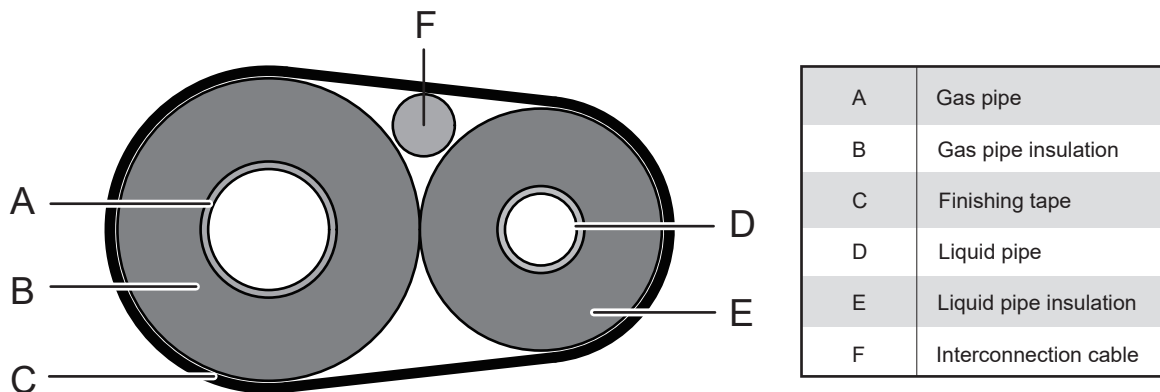

8 TEST RUNNING

Operate according to "key points for test running" on the electric control box cover.

⚠ CAUTION

- Test running can not start until all the valves are affirmed open.
- Never make the forced running. (Or the protector sits back, danger will occur.)

9 PRECAUTIONS ON REFRIGERANT LEAKAGE

In UL/CSA 60335-2-40, R32 refrigerant is classified as class A2L, which is mildly flammable. Therefore, R32 refrigerant is suitable for systems needing additional refrigerant charge and which will limit the area of the rooms being served by the system.

The total amount of refrigerant in the system shall be less than or equal to the allowable maximum refrigerant charge. The allowable maximum refrigerant charge depends on the area of the rooms being served by the system.

If the total refrigerant charge in the system is < 4.04 lb (1.835 kg), there are no additional installation room minimum floor area requirements. Use the first column of Table 1 to determine minimum floor area requirement of the installation room.

If the total refrigerant charge in the system is \geq 4.04 lb (1.835 kg), you need to comply with additional minimum floor area requirements as described in the following diagrams, tables and flow chart. The diagrams show an example installation room and, if required, a secondary natural ventilation room. The flow chart steps through the process of determining the minimum floor area requirement per the refrigerant charge and IDU installation height. The tables provide the values needed to step through the flow chart.

Table 1-Minimum floor area per refrigerant charge & IDU installation height: indoor unit.

Table 2-Minimum venting opening area to secondary room for natural ventilation: indoor unit.

⚠ CAUTION

The space considered shall be any space which contains refrigerant-containing parts or into which refrigerant could be released.

For installation of the indoor unit, refer to the corresponding installation and operation manual. If an indoor unit is installed in an unventilated area, the area shall be so constructed that should any refrigerant leak, it will not stagnate to create a fire or explosion hazard.

*installation height (h_0) is measured from the floor to the bottom of the indoor unit.

The room area (A) of the smallest, enclosed, occupied space shall be used in the determination of the refrigerant quantity limits.

For determination of room area (A) when used to calculate the refrigerant charge limit, the following shall apply. The room area (A) shall be defined as the room area enclosed by the projection to the base of the walls, partitions and doors of the space in which the appliance is installed.

Spaces connected by only drop ceilings, ductwork, or similar connections shall not be considered a single space. Units mounted higher than 70-7/8 in (1.8 m) and spaces divided by partition walls that are no higher than 62-7/8 in (1.6 m) shall be considered a single space.

Rooms on the same floor and connected by an open passageway between the spaces can be considered a single room when determining compliance to A_{min} , if the passageway complies with all the following.

- 1) It is a permanent opening.
- 2) It extends to the floor.
- 3) It is intended for people to walk through.

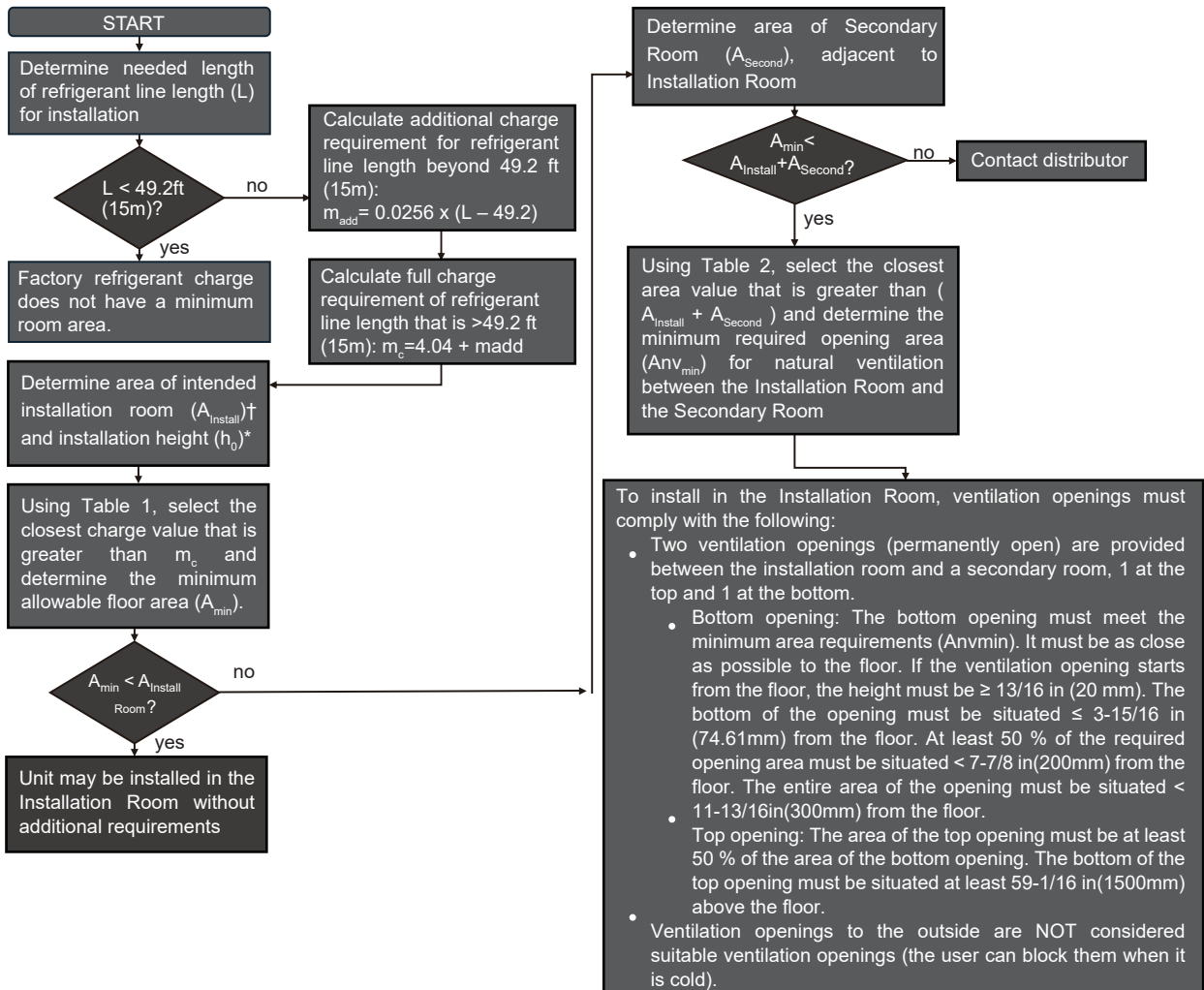
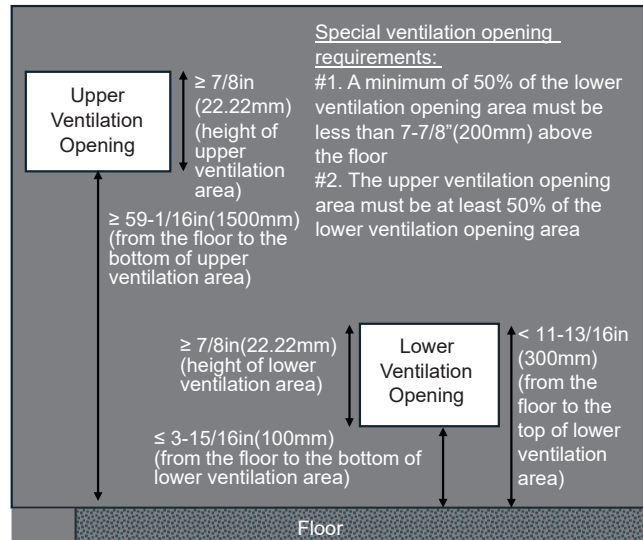
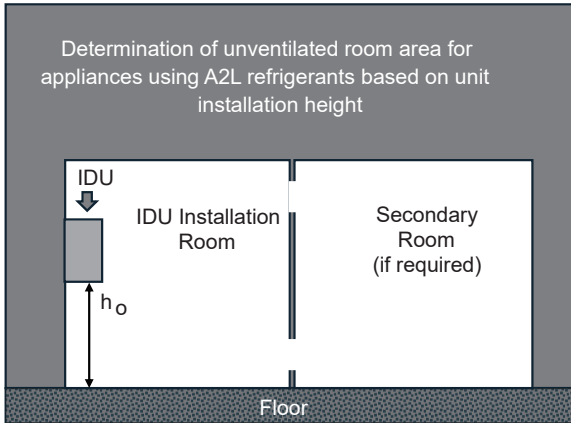

Table 1 - Minimum required Room Area

Refrigerant line length ft(m)	System Charge, m _{max} lbs(kg)	Install height-ho (in/m)					
		63 (1.6)	60 (1.52)	56 (1.42)	52 (1.32)	48 (1.22)	44 (1.12)
		Minimum room area, Amin(ft ² /m ²)					
≤49.2(15)	4.04(1.835)	No limit	No limit	No limit	No limit	No limit	No limit
55.8(17)	4.21(1.91)	83.9 (7.79)	88.1 (8.18)	94.4(8.77)	101.7(9.45)	110.2(10.24)	120.2(11.17)
62.3(19)	4.38(1.99)	87.3 (8.11)	91.6 (8.51)	98.2(9.12)	105.7(9.82)	114.5(10.64)	125.0(11.61)
68.9(21)	4.54(2.06)	90.6 (8.42)	95.1 (8.84)	101.9(9.47)	109.8(10.2)	118.9(11.05)	129.7(12.05)
75.4(23)	4.71(2.14)	94.0 (8.73)	98.6 (9.16)	105.7(9.82)	113.8(10.57)	123.3(11.45)	134.5(12.50)
82.0(25)	4.88(2.21)	97.3 (9.04)	102.2 (9.49)	109.5(10.17)	117.9(10.95)	127.7(11.86)	139.3(12.94)
88.6(27)	5.05(2.29)	100.6 (9.35)	105.7 (9.82)	113.2(10.52)	121.9(11.32)	132.1(12.27)	144.1(13.39)
95.1(29)	5.21(2.36)	104.0 (9.66)	109.2 (10.15)	117.0(10.87)	126.0(11.71)	136.5(12.68)	148.9(13.83)
98.4(30)	5.30(2.40)	105.6 (9.81)	110.9 (10.30)	118.9(11.05)	128.0(11.89)	138.7(12.89)	153.7(14.28)

Refrigerant line length ft(m)	System Charge, m _{max} lbs(kg)	Install height-ho (in/m)				
		40 (1.02)	36 (0.91)	32 (0.81)	28 (0.71)	24 (0.61)
		Minimum room area, Amin(ft ² /m ²)				
≤49.2(15)	4.04(1.835)	No limit	No limit	No limit	No limit	No limit
55.8(17)	4.21(1.91)	132.2 (12.28)	146.9 (13.65)	183.4 (17.04)	239.6 (22.26)	326.1 (30.30)
62.3(19)	4.38(1.99)	137.4 (12.76)	156.7 (14.56)	198.3 (18.42)	259.0 (24.06)	352.5 (32.75)
68.9(21)	4.54(2.06)	142.7 (13.26)	168.9 (15.69)	213.8 (19.86)	279.2 (25.94)	380.1 (35.31)
75.4(23)	4.71(2.14)	148.0 (13.75)	181.6 (16.87)	229.8 (21.35)	300.2 (27.89)	408.6 (37.96)
82.0(25)	4.88(2.21)	157.7 (14.65)	194.7 (18.09)	246.5 (22.90)	321.9 (29.91)	438.2 (40.71)
88.6(27)	5.05(2.29)	168.8 (15.68)	208.4 (19.36)	263.7 (24.50)	344.4 (32.00)	468.8 (43.55)
95.1(29)	5.21(2.36)	180.2 (16.74)	222.4 (20.66)	281.5 (26.15)	367.7 (34.16)	500.4 (46.49)
98.4(30)	5.30(2.40)	186.0 (17.28)	229.6 (21.33)	290.6 (27.00)	379.6 (35.27)	516.7 (48.00)

Table 2 - Minimum required Ventilation Opening

Room area (ft ² /m ²)	Install height-ho (in/m)					
	63 (1.6)	60 (1.52)	56 (1.42)	52 (1.32)	48 (1.22)	44 (1.12)
	Minimum Ventilation Opening, Anvmin (in ² /cm ²)					
515(47.85)	---	---	---	---	---	---
450(41.81)	---	---	---	---	---	---
400(37.16)	---	---	---	---	---	---
350(32.52)	---	---	---	---	---	---
250(23.23)	---	---	---	---	---	---
200(18.58)	---	---	---	---	---	---
150(13.94)	---	---	---	---	---	1.5 (9.68)
95(8.83)	---	---	---	7.8 (50.32)	16.4 (105.81)	25.8 (166.45)
75(6.97)	---	4.5 (29.03)	11.1 (71.61)	18.3 (118.06)	26 (167.74)	34.4 (221.94)
40(3.72)	22 (141.94)	25.4 (163.87)	30.3 (195.48)	35.6 (229.68)	41.4 (267.1)	47.8 (308.39)

Room area (ft ² /m ²)	Install height-ho (in/m)				
	40 (1.02)	36 (0.91)	32 (0.81)	28 (0.71)	24 (0.61)
	Minimum Ventilation Opening, Anvmin (in ² /cm ²)				
515(47.85)	---	---	---	---	0.1 (0.65)
450(41.81)	---	---	---	---	15.9 (102.58)
400(37.16)	---	---	---	---	28 (180.64)
350(32.52)	---	---	---	8.1 (52.26)	40 (258.06)
250(23.23)	---	---	12.9 (83.23)	36.3 (234.19)	63.5 (409.68)
200(18.58)	---	10.6 (68.39)	29 (187.1)	50.1 (323.23)	74.6 (481.29)
150(13.94)	14.4 (92.9)	28.7 (185.16)	44.8 (289.03)	63.2 (407.74)	84.8 (547.1)
95(8.83)	36.2 (233.55)	47.8 (308.39)	60.8 (392.26)	75.9 (489.68)	93.8 (605.16)
75(6.97)	43.7 (281.93)	54.1 (349.03)	65.9 (425.16)	79.6 (513.55)	95.8 (618.06)
40(3.72)	54.9 (354.19)	62.9 (405.81)	72 (464.52)	82.7 (533.55)	95.5 (616.13)

10 HAND-OVER

The owner's manual of indoor unit and owner's manual of outdoor unit must be turned over to the customer. Explain the contents in the owner's manual to the customers in details.

⚠ WARNING

- **Ask your dealer for installation of the heat pump.**
Incomplete installation performed by yourself may result in a water leakage, electric shock, and fire.
- **Ask your dealer for improvement, repair, and maintenance.**
Incomplete improvement, repair, and maintenance may result in a water leakage, electric shock, and fire.
- **In order to avoid electric shock, fire or injury, or if you detect any abnormality such as smell of fire, turn off the power supply and call your dealer for instructions.**
- **Never let the indoor unit or the remote controller get wet.**
It may cause an electric shock or a fire.
- **Never press the button of the remote controller with a hard, pointed object.**
The remote controller may be damaged.
- **Never replace a fuse with that of wrong rated current or other wires when a fuse blows out.**
Use of wire or copper wire may cause the unit to break down or cause a fire.
- **It is not good for your health to expose your body to the air flow for a long time.**
- **Do not insert fingers, rods or other objects into the air inlet or outlet.**
When the fan is rotating at high speed, it will cause injury.
- **Never use a flammable spray such as hair spray, lacquer or paint near the unit.**
It may cause a fire.
- **Never put any objects into the air inlet or outlet.**
Objects touching the fan at high speed can be dangerous.
- **Do not dispose this product as unsorted municipal waste. Collection of such waste separately for special treatment is necessary.**
- Do not dispose of electrical appliances as unsorted municipal waste, use separate collection facilities.
Contact you local government for information regarding the connection systems available.



- **If electrical appliances are disposed of in landfills or dumps, hazardous substances can leak into the groundwater and get into the food chain, damaging your health and well-being.**
To prevent refrigerant leak, contact your dealer.
When the system is installed and runs in a small room, it is required to keep the concentration of the refrigerant, if by any chance coming out, below the limit. Otherwise, oxygen in the room may be affected, resulting in a serious accident.
- **The refrigerant in the heat pump is safe and normally does not leak.**
If the refrigerant leaks in the room, contact with a fire of a burner, a heater or a cooker may result in a harmful gas.
- **Turn off any combustible heating devices, ventilate the room, and contact the dealer where you purchased the unit.**
- Do not use the heat pump until a service person confirms that the portion where the refrigerant leaks is repaired.

⚠ CAUTION

- **Do not use the heat pump for other purposes.**

In order to avoid any quality deterioration, do not use the unit for cooling precision instruments, food, plants, animals or works of art.

- **Before cleaning, be sure to stop the operation, turn the breaker off or pull out the supply cord.**

Otherwise, an electric shock and injury may result.

- **In order to avoid electric shock or fire, make sure that an earth leak detector is installed.**

- **Be sure the heat pump is earthed.**

In order to avoid electric shock, make sure that the unit is grounded and that the earth wire is not connected to gas or water pipe, lightning conductor or telephone earth wire.

- **In order to avoid injury, do not remove the fan guard of the outdoor unit.**

- **Do not operate the heat pump with a wet hand.**

An electric shock may happen.

- **Do not touch the heat exchanger fins.**

These fins are sharp and could result in cutting injuries.

- **Do not place items which might be damaged by moisture under the indoor unit.**

Condensation may form if the humidity is above 80%, the drain outlet is blocked or the filter is polluted.

- **After a long use, check the unit stand and fitting for damage.**

If damaged, the unit may fall and result in injury.

- **To avoid oxygen deficiency, ventilate the room sufficiently if equipment with burner is used together with the heat pump.**

Arrange the drain hose to ensure smooth drainage.

Incomplete drainage may cause wetting of the building, furniture etc.

- **Never touch the internal parts of the controller.**

Do not remove the front panel. Some parts inside are dangerous to touch, and a machine trouble may happen.

- **Never do the maintenances work by yourself.**

Please contact your local dealer to do the maintenances work.

- **Never expose little children, plants or animals directly to the air flow.**

Adverse influence to little children, animals and plants may result.

- **Do not allow a child to mount on the outdoor unit or avoid placing any object on it.**

Falling or tumbling may result in injury.

- **Do not operate the heat pump when using a room fumigation - type insecticide.**

Failure to observe could cause the chemicals to become deposited in the unit, which could endanger the health of those who are hypersensitive to chemicals.

- **Do not place appliances which produce open fire in places exposed to the air flow from the unit or under the indoor unit.**

It may cause incomplete combustion or deformation of the unit due to the heat.

- **Do not install the heat pump at any place where flammable gas may leak out.**

If the gas leaks out and stays around the heat pump, a fire may break out.

- **The appliance is not intended for use by young children or infirm persons without supervision.**

- **Young children should be supervised to ensure that they do not play with the appliance.**

- **The outdoor unit window-shades should be periodic cleaning in case of being jammed.**

This window-shapes is heat dissipation outlet of components, if being jammed will cause the components shorten their service life spans because of overheated for a long time.

- **The temperature of refrigerant circuit will be high, please keep the interconnection cable away from the copper tube.**

11 OPERATION AND PERFORMANCE

11.1 Protection equipment

This Protection Equipment will enable the Heat Pump to stop when the Heat Pump is to be directed running compulsively. The protection equipment may be activated in following conditions:

■ Cooling Operation

- The air inlet or air outlet of outdoor unit is blocked.
- Strong wind is Continuously blowing to the air outlet of the outdoor unit.

■ Heating Operation

- Too much rubbish adhere to the filter in the water system.
- The air outlet of indoor unit is choked.
- Mishandling in operation:

If mishandling happens because of lighting or mobile wireless, please shut off the manual power switch, and turn on again, then push the ON/OFF button.

NOTICE

When the protection equipment starts, please shut down the manual power switch, and restart operation after problem is solved.

11.2 About power cut

- If power is cut during operation, stop all the operation immediately
- Power comes again. If the auto-restart function is set on, then the unit will auto-restart.

11.3 Heating capacity

- The heating operation is a heat-pump process that heat will be absorbed from outdoor air and released to indoor water. Once the outdoor temperature is decreased, heating capacity decreased correspondingly.
- Other heating equipment is suggested to be used together when outdoor temperature is too low.
- In some extreme cold upland that buy the indoor unit equipped with electrical heater will obtain better performance.(Refer to indoor unit owner's manual for details)

NOTICE

- 1.The motor in outdoor Unit will continue running for 60 seconds for to remove residual heat when the outdoor Unit receiving OFF command during heating operation.
- 2.If the heat pump malfunction occurs because of disturb, please reconnect the heat pump to power, then turn on it again.

11.4 Compressor protection feature

- A protection feature prevents the heat pump from being activated for approximately several minutes when it restarts immediately after operation.

11.5 Cooling and heating operation

- An indoor unit in the same system can not run cooling and heating at the same time.
- If the Heat Pump Administrator has set running mode, then the heat pump can not run on modes other than the presetted. Standby or No Priority will be displayed in the Control Panel.

11.6 Features of heating operation

- Water will not become hot immediately at the beginning of the heating operation, it takes approximately 3-5 minutes for the heat pump to provide energy to the indoor heat exchanger, then the water temperature will increase.
- During operation, the fan motor in the outdoor unit may stop running under high temperature.

11.7 Defrost in the heating operation

- During heating operation, outdoor unit sometimes will frost. To increase efficiency, the unit will start defrosting automatically (about 2~10 minutes), and then water will be drained out from outdoor unit.
- During defrosting, the fan motors in the outdoor unit will stop running.

11.8 Error codes

When a safety device is activated, an error code will be displayed on the user interface.

A list of all errors and corrective actions can be found in the table below.

Reset the safety by turning the unit OFF and back ON.

In case this procedure for resetting the safety is not successful, contact your local dealer.

ERROR CODE	MALFUNCTION OR PROTECTION	FAILURE CAUSE AND CORRECTIVE ACTION
<i>bH</i>	PED PCB failure	<ol style="list-style-type: none"> 1. After 5 minutes of power-off interval, power on again and observe whether it can be recovered; 2. If it can't be restored, replace PED safety plate, power on again, and observe whether it can be restored; 3. If it can not be recovered, the IPM module board should be replaced.
<i>E7</i>	High temperature protection of inverter module heat sink	<ol style="list-style-type: none"> 1. Power supply voltage of the unit is low, increase the power voltage to the required range. 2. The space between the units is too narrow for heat exchange. Increase the space between the units. 3. Heat exchanger is dirty or something is block on the surface. Clean the heat exchanger or remove the obstruction. 4. Fan is not running. Fan motor or fan is broken, Change a new fan or fan motor. 5. Water flow rate is low, there is air in system, or pump head is not enough. Release the air and reselect the pump. 6. Water outlet temp.sensor is loosen or broken, reconnect it or change a new one.
<i>E5</i>	Outdoor unit heat exchanger temperature sensor (T3) fault	<ol style="list-style-type: none"> 1. The T3 sensor connector is loosened. Reconnect it. 2. The T3 sensor connector is wet or there is water in. remove the water, make the connector dry. Add waterproof adhesive 3. The T3 sensor failure, change a new sensor.
<i>E6</i>	Outdoor unit ambient temperature sensor (T4) fault	<ol style="list-style-type: none"> 1. The T4 sensor connector is loosened. Reconnect it. 2. The T4 sensor connector is wet or there is water in. remove the water, make the connector dry. Add waterproof adhesive 3. The T4 sensor failure, change a new sensor.

ERROR CODE	MALFUNCTION OR PROTECTION	FAILURE CAUSE AND CORRECTIVE ACTION
<i>E9</i>	Compressor suction line temperature sensor (Th) fault	<ol style="list-style-type: none"> 1. The Th sensor connector is loosened. Reconnect it. 2. The Th sensor connector is wet or there is water in. remove the water, make the connector dry. Add waterproof adhesive 3. The Th sensor failure, change a new sensor.
<i>EA</i>	Compressor discharge line temperature sensor (Tp) fault	<ol style="list-style-type: none"> 1. The Tp sensor connector is loosened. Re connect it. 2. The Tp sensor connector is wet or there is water in. remove the water, make the connector dry. Add waterproof adhesive 3. The Tp sensor failure, change a new sensor.
<i>HO</i>	Communication fault between hydro-box and outdoor unit	<ol style="list-style-type: none"> 1. The communication wire between main control board(PCB B) of the outdoor unit and the control board of the indoor unit is not connected properly. Connect the wires correctly. 2. Whether there is a high magnetic field or high power interfere, such as lifts, large power transformers, etc.. To add a barrier to protect the unit or to move the unit to the other place
<i>HI</i>	Communication fault between Main control board and inverter module board	<ol style="list-style-type: none"> 1. Whether there is power connected to the PCB and driven board. Check the inverter module PCB indicator light is on or off. If Light is off, reconnect the power supply wire. 2. if light is on, check the wire connection between inverter module PCB and main control board PCB, if the wire loosen or broken, reconnect the wire or change a new wire. 3. Replace a new main PCB and driven board in turn.
<i>H4</i>	Three times L0/L1 protects	The sum of the number of times L0 and L1 appear in an hour equals three. See L0 and L1 for fault handling methods.
<i>H6</i>	DC fan motor fault	<ol style="list-style-type: none"> 1. Strong wind blowing toward the fan, causing the fan to rotate in the opposite direction. Change the unit direction or make a shelter to protect against strong winds. 2. Fan motor is broken, change a new fan motor.

ERROR CODE	MALFUNCTION OR PROTECTION	FAILURE CAUSE AND CORRECTIVE ACTION
<i>H7</i>	AC voltage protection	<ol style="list-style-type: none"> 1. Whether the power supply input is in the specified range. 2. Power off and power on for several times rapidly in short time. 3. Keep the power off for more than 3min and then turn it on again, if the fault still exists, you need to replace the PCB board with a new one
<i>H8</i>	Pressure sensor fault	<ol style="list-style-type: none"> 1. Pressure sensor connector is loosen, reconnect it. 2. Pressure sensor failure. change a new sensor.
<i>HF</i>	Outdoor unit EEPROM fault	<ol style="list-style-type: none"> 1. The EEPROM parameter is error, rewrite the EEPROM data. 2. EEPROM chip part is broken, change a new EEPROM chip part. 3. Inverter module board is broken, change a new PCB.
<i>HH</i>	10 times H6 in 120 minutes	Refer to H6
<i>HP</i>	Low pressure protection in cooling mode	Refer to H6
<i>PO</i>	Heat pump system low pressure protection	<ol style="list-style-type: none"> 1. System is low on refrigerant. Charge the system with additional refrigerant. 2. When at heating mode or DHW mode, the outdoor heating exchanger is dirty or something is block on the surface. Clean the outdoor heating exchanger or remove the obstruction. 3. The water flow is too low in cooling mode. increase the water flow. 4. Electrical expansion valve locked or winding connector is loosen. Tap the valve body and plug in and unplug the connector several times to make sure the valve is working correctly.

ERROR CODE	MALFUNCTION OR PROTECTION	FAILURE CAUSE AND CORRECTIVE ACTION
<i>P1</i>	Heat pump system high pressure protection	Heating mode, DHW mode: <ol style="list-style-type: none"> 1. The water flow is low; water temp is high, whether there is air in the water system. Release the air. 2. Water pressure is lower than 14.5 psi (1 bar), add water to increase the pressure in the range of 20-25 psi (1.38-1.72 bar). 3. Over charge of the refrigerant volume. Recharge the refrigerant in right volume. 4. Electrical expansion valve locked or winding connector is loosed. Tap the valve body and plug in and unplug the connector several times to make sure the valve is working correctly. Cooling mode: Ensure that the machine is correctly installed <ol style="list-style-type: none"> 1. Heat exchanger cover is not removed. Remove it. 2. Heat exchanger is dirty or something is block on the surface. Clean the heat exchanger or remove the obstruction.
<i>P3</i>	AC current protection	<ol style="list-style-type: none"> 1. The same Failure Cause and Corrective Actions as shown for Error Code P1. 2. Power supply voltage of the unit is low, increase the power voltage to the required range.
<i>P4</i>	Compressor discharge temperature high protection	<ol style="list-style-type: none"> 1. The same Failure Cause and Corrective Actions as shown for Error Code P1. 2. TW_out temp.sensor is loosen Reconnect it.. 3. T1 temp.sensor is loosen. Reconnect it. 4. T5 temp.sensor is loosen. Reconnect it.
<i>Pd</i>	Outdoor exchanger temperature (T3) high protection	<ol style="list-style-type: none"> 1. Heat exchanger cover is not removed. Remove it. 2. Heat exchanger is dirty or something is block on the surface. Clean the heat exchanger or remove the obstruction. 3. There is no enough space around the unit for heat exchanging. 4. fan motor is broken, replace a new one.
<i>F1</i>	DC bus low voltage protection	<ol style="list-style-type: none"> 1. Check the power supply. 2. If the power supply is OK, and check if LED light is OK, check the voltage PN, if it is 380 V, the problem usually comes from the main board. And if the light is OFF, disconnect the power, check the IGBT, check those dioxides, if the voltage is not correct, the inverter board is damaged, change it. 3. And if those IGBT are OK, which means the inverter board is OK, power form rectifier bridge is not correct, check the bridge. (Same method as IGBT, disconnect the power, check those dioxides are damaged or not). 4. Usually if F1 exist when compressor start, the possible reason is main board. If F1 exist when fan start, it may be because of inverter board.

	ERROR CODE	MALFUNCTION OR PROTECTION	FAILURE CAUSE AND CORRECTIVE ACTION
P6	L0	DC compressor inverter module fault	<ol style="list-style-type: none"> 1. Check the Heat pump system pressure; 2. Check the phase resistance of compressor; 3. Check the U、 V、 W power line connection sequence between the inverter board and the compressor; 4. Check the L1、 L2、 L3 power line connection between the inverter board and the Filter board; 5. Check the inverter board.
	L1	DC bus low voltage protection	
	L2	DC bus high voltage protection	
	L4	MCE malfunction	
	L5	Zero speed protection	
	P6	Inverter module protection	
	L7	Phase loss protection	
	L8	Compressor frequency variation greater than 15 Hz within one second protection	
	L9	Speed difference > 15 Hz protection between the real and the setting speed	

12 TECHNICAL SPECIFICATIONS

Model	16kW	14kW	12kW
Power supply	208/230 V~ 60 Hz		
Rated current	26.0 A	25.0 A	24.5 A
Dimensions (W×H×D)[in/mm]	44 x 34-1/16 x 20-9/16 (1118 x 865 x 522)		
Fan motor	DC motor / Horizontal		
Compressor	DC inverter dual rotary		
Heat exchanger	Fin-coil		
Refrigerant			
Type	R32		
Quantity	4.04 lb (1.835 kg)		
Weight			
Net weight	216.05 lb (98 kg)		
Connections			
Liquid side	3/8 in (9.53 mm)		
Gas side	5/8 in (15.88 mm)		
Drain connection (Outside diameter)	1 1/4" (31.75 mm)		
Max. piping length	98 ft (30 m)		
Max. difference in height	65 ft (20 m)		
Refrigerant to be added	0.0256 lb/ft (0.038 kg/m)		
Operation ambient temperature range			
Heating mode	-13 °F to 95 °F (-25 °C to 35 °C)		
Cooling mode	23 °F to 110 °F (-5 °C to 43 °C)		
Domestic hot water mode	-13 °F to 110 °F (-25 °C to 43 °C)		

13 DISPOSAL

Comply with national regulations.

Components and accessories from the units are not part of ordinary domestic waste.

Complete units, compressors, motors etc. are only to be disposed of via qualified disposal specialists.

This unit uses flammable refrigerant R32. Please contact the dealer when you want to dispose of this unit. Law requires that the collection, transportation and disposal of refrigerants must conform with the regulations governing the collection and destruction of hydrofluorocarbons.

ANNEX A: REFRIGERANT CYCLE

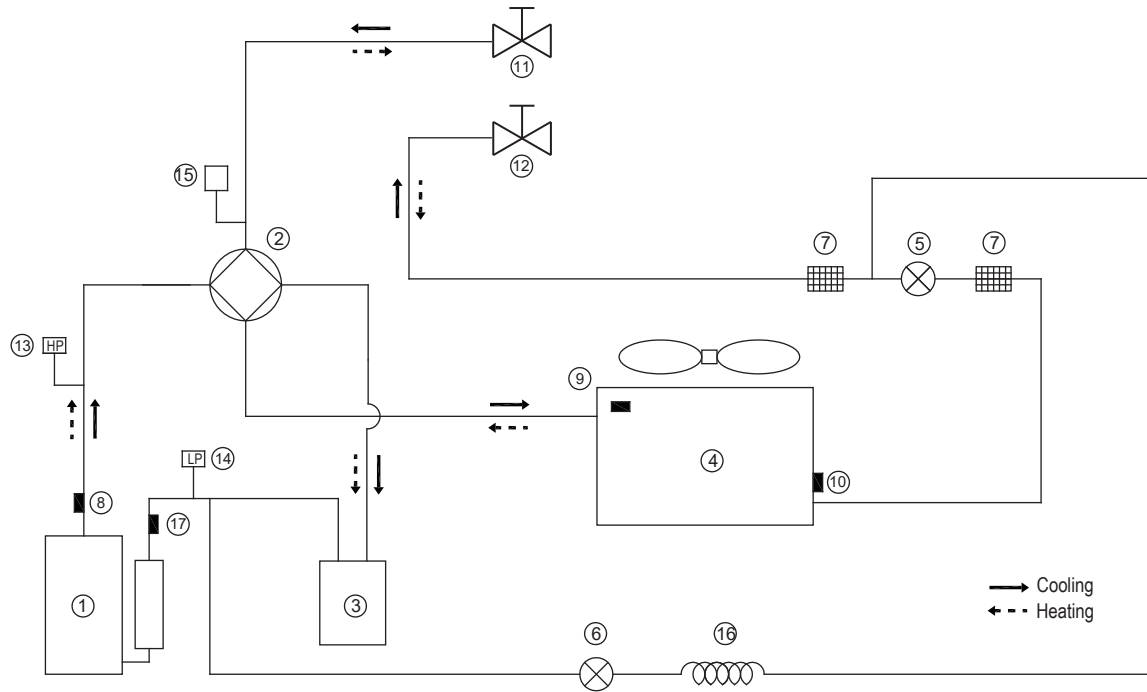

Item	Description	Item	Description
1	Compressor	10	Evaporation sensor in heating (Condenser sensor in cooling)
2	4-Way Valve	11	Stop valve (gas)
3	Gas-liquid separator	12	Stop valve (liquid)
4	Air side heat exchanger	13	High Pressure Switch
5	Electronic expansion Valve	14	Low Pressure Switch
6	Single-way electromagnetic valve	15	Pressure sensor
7	Filter	16	Capillary
8	Discharge temperature sensor	17	Suction temperature sensor
9	Outdoor temperature sensor		

ANNEX B: TO INSTALL THE E-HEATING TAPE AT THE DRAIN OUTLET (FIELD INSTALLATION)

Connect the heating tape wire at the drainage outlet to the wire joint XT3.

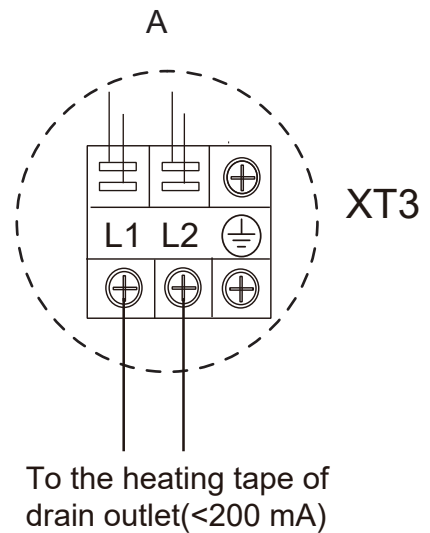
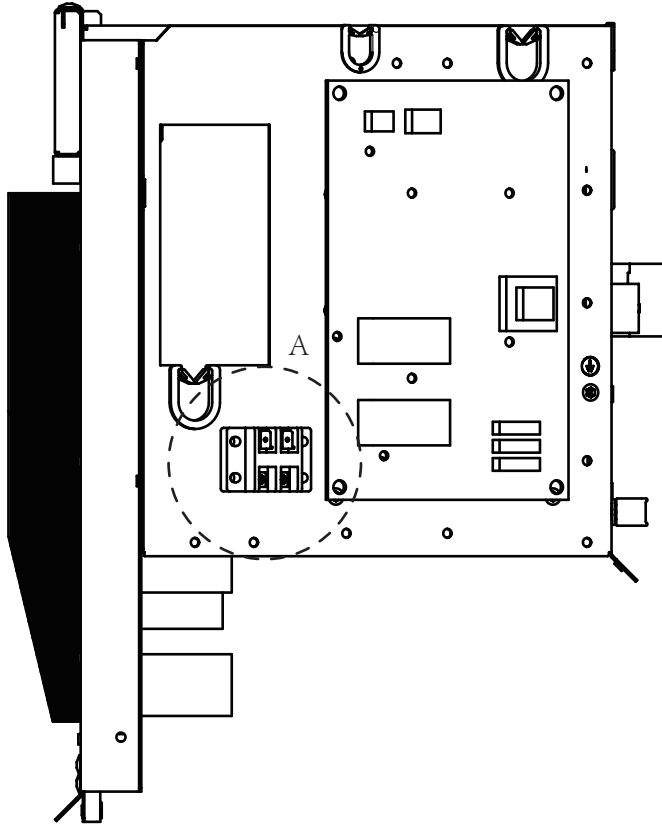

NOTICE

The picture is for reference only,
please refer to the actual product.

The power of the E-heating tape
shall not exceed 40 W/200 mA,
supply voltage 208/230 V AC.