

2 0 1 9  
EUROPE

ENGLISH

# ACRYLIC SOLID SURFACE

WIDE MATERIAL  
FOR WIDE IDEAS

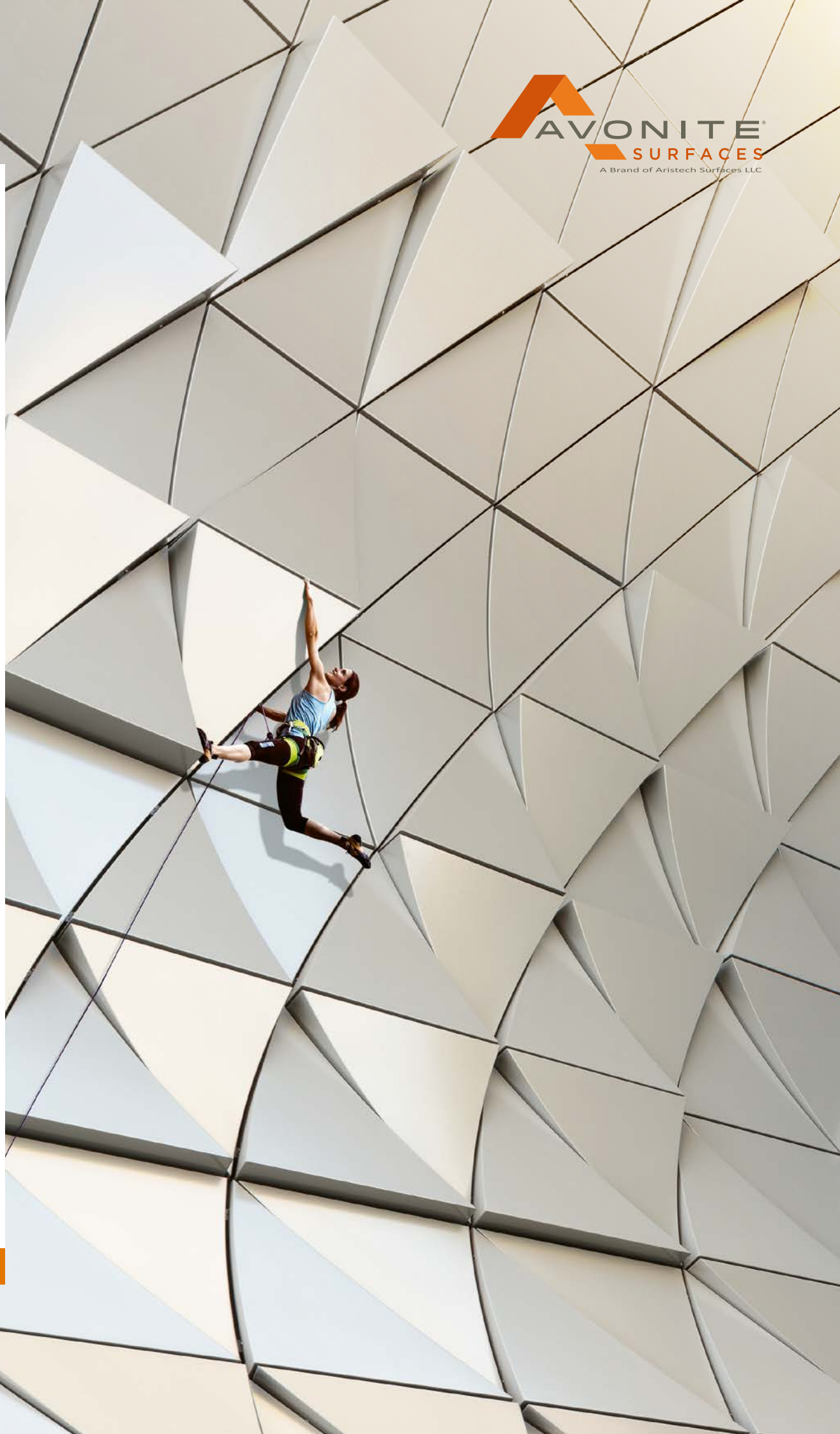

# AVONITE®

**WIDE AND  
FLEXIBLE.  
THE SOLUTION  
TO ACCOMPLISH  
YOUR BOLDEST  
PROJECTS.**

AVONITE® is a solid surface material composed of 63% alumina trihydrate, 35% acrylic and 2% pigments and binders. It is produced at the Aristech Surfaces LLC plant, in Florence (KY), USA, one of the most flexible and scalable production lines in the world. Aristech Surfaces LLC relies on its experience and expertise to supply a reliable Solid Surface material.

## COLOURFUL

Complimented by a range of colours specially selected to serve the European market, AVONITE® offers tones and textures suited to the creation of harmonious spaces. Homogeneous throughout its thickness, the material allows for careful cutouts, as well as the sanding of its surface, capable of giving it a lustred sheen at all times.



## THERMOFORMABLE

AVONITE® sheets become supple and malleable when exposed to the heat of special ovens. One thing is certain: with its organic shapes and rounded corners, the material's gentle curves provide comfort and warmth to any interior design.



## TRANSLUCENT

Whether through the even and glossy translucence of Ice White or the creation of motifs trimmed in lighter colours, AVONITE® offers beautiful ways to treat light.



## MONOLITHIC

AVONITE® adhesives are colour matched exactly to ensure seamless joints. Now you can create monolithic installations and counters stretching as far as the eye can see!



# ONE OF THE MOST ADVANCED PRODUCTION TECHNOLOGIES

The ability of our double belt production lines to create a multi-stage system, incorporating controlled heating, cooling and tempering – all within one press – enables the development of highly efficient processing solutions.

MORE DETAILS [PAGE 12](#)

# RIGHT SIZE PROGRAMME

## OUR STANDARD FORMATS

AVONITE®'s **RIGHT SIZE** Programme refers to 18 formats of sheets with NO surcharges per m<sup>2</sup>.

With perfectly reasonable minimum order sizes, the **RIGHT SIZE** Programme lets you acquire sheets of all sizes.

MORE DETAILS [PAGE 14](#)





# OUR COMMITMENT TO ECOLOGY

We see sustainability as more than just offering products with recycled content and regulatory compliance. It means having a responsibility to touch and improve lives by making a positive impact on others, now and for the future.

MORE DETAILS **PAGE 16**



The exterior facade of this luxurious villa in Ibiza was created with AVONITE®, as well as the windows' and doors' frames, the swimming pool outline, the columns of the terrace and the surface of the outer wall.

Private Villa Can Furnet  
Ibiza, Spain  
**AVONITE® Snowfall 8090**



Designer: Laurence Sonck  
Fabricator: M² IBIZA CONSTRUCT SL  
Photographer: Arsen Mikitov



## EXTERIOR

### A NETWORK OF EXPERTS

We have a network of Solid Surface experts experienced in building facades, using our ETA certified AVONITE®, which you can aspire to use on the most ambitious projects.

The **RIGHT SIZE** Programme also offers a competitive product portfolio that is perfectly suited to the creation of exterior façades.

For outdoor use, AVONITE® recommends 7 colours (see p .18), for which we predict a UV resistance under  $\Delta E 5$  and gloss loss of less than 40% for a matt finish.

Location: Béziers, France  
Photographer: Hugo Da Costa  
Fabricator: LCCA  
Architect: Olivier Marty  
**AVONITE® Super White 8026**



In the offices of the German company Schlüter Systems, translucent motifs were milled in the material to create a stunning light effect. AVONITE® was also used as a surface for the cloakroom furniture.

Schlüter Systems KG  
Iserlohn, Germany  
**AVONITE® Polaris 8256**



## COMMERCIAL

### **AVONITE® IS ABSOLUTELY VERSATILE**

It can be found on both the countertops and walls of ultra-clean labs and the overworked reception desks at hotels.

### **THAT'S NOT ALL**

AVONITE® is also used to produce flawless furniture for shops and museums.





AVONITE® Polaris 8256

## HYGIENIC

The material's non-porous properties and the seamless assembly of furniture made of AVONITE® makes it extremely easy to clean. Its thermoforming capacity also allows for the creation of rounded backsplashes on lab benches, kitchen counters and restaurant furniture, which eliminates those hard to reach places.



## DURABLE

AVONITE® is resistant to common household products and is easy to repair, thanks to the after sale servicing by one of our local partners. With its 15-year warranty on 12 and 6 mm thicknesses and 1 year warranty on the 3 mm thickness, AVONITE® will not fail you after your project is complete.





Design/fabricator/photo: Carpintek  
**AVONITE® Snowfall 8090**

## RESIDENTIAL

---

Used for kitchen islands, vanity tops and shower bases in bathrooms, or modern furnishings, AVONITE® fits harmoniously into private residences.

---



## ADVANC3®

**ARE YOU LOOKING FOR AN ALTERNATIVE  
TO LAMINATE AS A FURNITURE COVERING?**

**AVONITE® IS A GREAT SOLUTION!**

With its sheets just 3 mm thick, AVONITE® ADVANC3® offers all the properties and aesthetics of a Solid Surface at unbeatable prices. ADVANC3® can only be used on installations with no heat source at proximity.

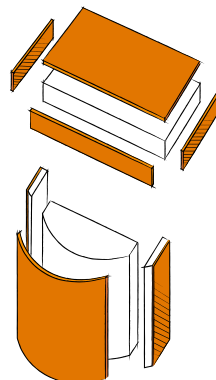

**ADVANCE®**

# ONE OF THE MOST ADVANCED PRODUCTION TECHNOLOGIES

**THE ABILITY OF OUR DOUBLE BELT PRODUCTION LINES TO CREATE A MULTI-STAGE SYSTEM, INCORPORATING CONTROLLED HEATING, COOLING AND TEMPERING – ALL WITHIN ONE PRESS – ENABLES THE DEVELOPMENT OF HIGHLY EFFICIENT PROCESSING SOLUTIONS.**

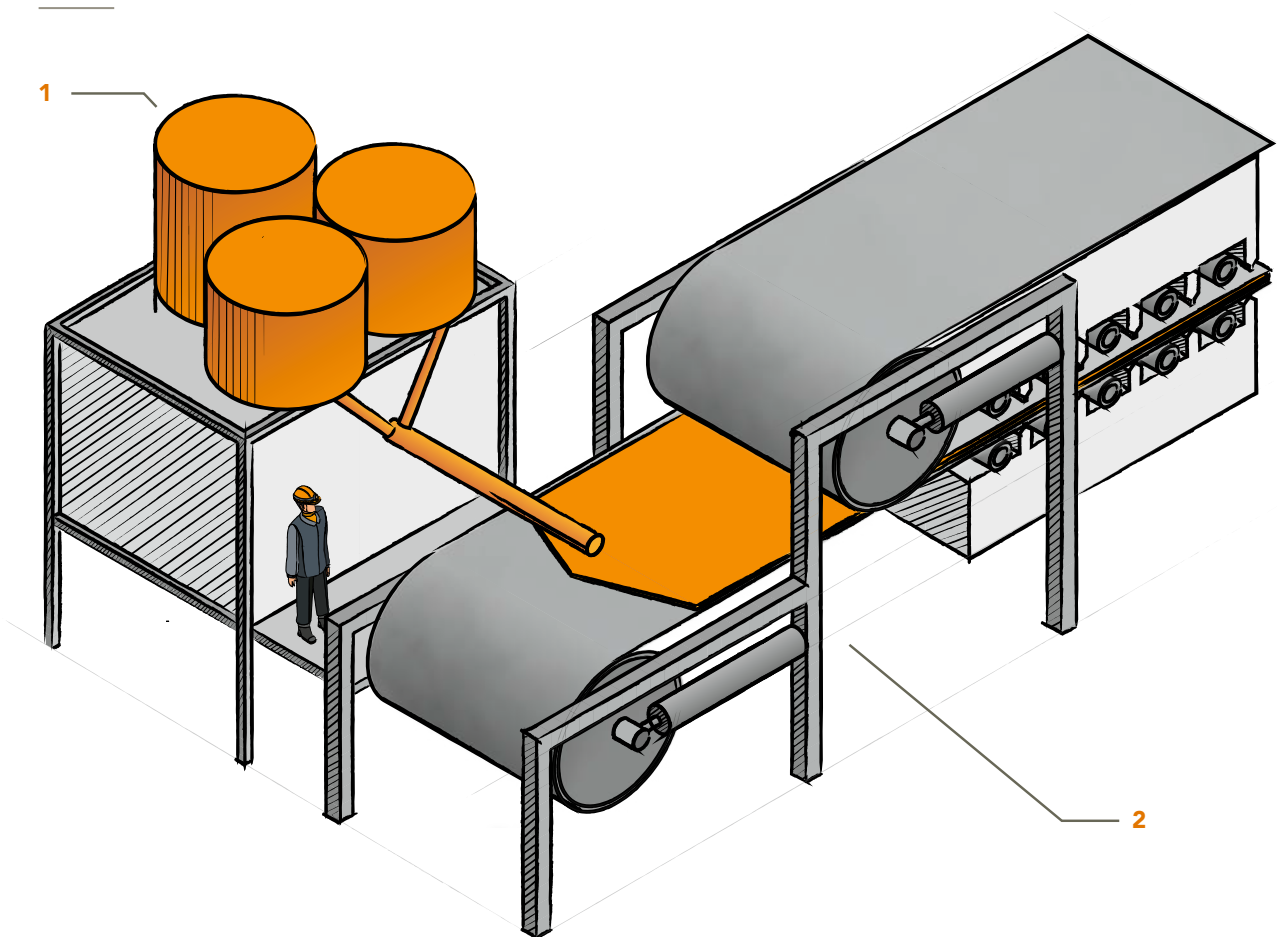

**1** The manufacturing process begins with mixing of the constituent materials (Methyl Methacrylate, solution of pre-polymerised methyl methacrylate, Alumina Trihydrate, pigments, catalysts, and chips, if needed) in a batch vessel. The use of a batch vessel for mixing all the ingredients ensures that a well-mixed homogeneous mixture is delivered to the double-belt continuous cast process.

**2** The compound product is then cast between the belts. Through the application of heat and pressure, the product is pressed, calibrated and cooled down under pressure. This system enables very high pressure to be delivered uniformly.

Often associated with a continuous cast production line, a double belt press typically includes top and bottom belts with heating elements and pressure mechanisms that transfer heat and pressure to the products between the belts. One of the major advantages to this machine is its ability to continuously hold product under heat for and cool to set good strength. Product is held securely throughout complete process.

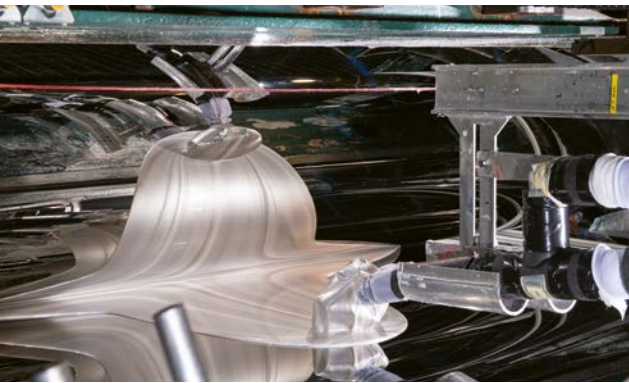

## BENEFITS OF OUR TECHNOLOGY

### VERSATILE ADJUSTABLE PRODUCT WIDTH

The use of a double-belt continuous cast process allows the adjustment of the product width to any size between 686 mm and 1524 mm. Thanks to this highly efficient process, Aristech Surfaces LLC offers 3 different widths at no surcharge cost per m<sup>2</sup> and any other width between 686 mm and 1524 mm at a highly competitive price.

### IMPECCABLE COLOUR CONSISTENCY

Continuous-casting optimises the mixing of ingredients to offer a perfect colour consistency not only within the same batch but even within different production batches ( $\Delta E < 1$ ).

### NARROW THICKNESS TOLERANCE

The thickness of the product – taking into account the shrinking effect – is easily adjusted by means of a high precision gear and spindle system that sets the gap between upper and lower belt. Consequence? AVONITE®'s tolerance on the thickness across a sheet is the lowest among any other Acrylic Solid Surface. Precision in manufacturing is key for the most ambitious projects and AVONITE® is meant to be part of them.

### ECO-FRIENDLY MANUFACTURING

Realised without solvent and from a 100% monomer solution, the bulk polymerization of methyl methacrylate produced in the double-belt manufacturing process contributes to reduce the impact of Volatile Organic Compounds on environment. That's how AVONITE® has been classified by SCS Global Services at the most demanding level "Indoor Advantage Gold" for its capacity to preserve indoor air quality. And that's not all: with its symmetric heating and cooling system, this highly efficient system contributes to save energy. Finally, continuous-casting improves the yield and reduces scrap for an optimised usage of resources.

# OUR RIGHT SIZE PROGRAMME



## OUR 18 STANDARD FORMATS

AVONITE®'s **RIGHT SIZE** Programme refers to 18 formats of sheets **WITH NO SURCHARGES PER M<sup>2</sup>**.

- Thickness: 12 mm\*.
- Lengths: 2438 mm | 3048 mm | 3658 mm.
- Widths: 762 mm | 914 mm | 1067 mm | 1219 mm | 1372 mm | 1524 mm.

\* The **RIGHT SIZE** Programme applies to any standard AVONITE Surfaces® colour in 12 mm thickness, with the exception of 8064 Ice White, 8298 Ice Blue, 8901 Altitude, 8903 Torrent, 8904 Morning Mist, 8905 Summit, 8908 Calm and 8909 Unwind. Please contact your local distributor to get the list. Lead time and minimum order quantity will apply.

### DO YOU HAVE A SMALL PROJECT THAT DOES NOT MEET THE ORDER MINIMUM?

We have not forgotten you. A large selection of **RIGHT SIZE** formats is available in our European stock, in our most popular colour: **SNOWFALL**. See P20.

### USING THE RIGHT FORMAT OF SHEETS IS THE RIGHT CHOICE FOR CONSUMING LESS.

The use of large sheets reduces the number of joints required. Fewer joints mean less adhesive, less work and therefore less cost to the end user.

The choice of an optimal format reduces scrap. Less scrap means taking a step to help the environment.

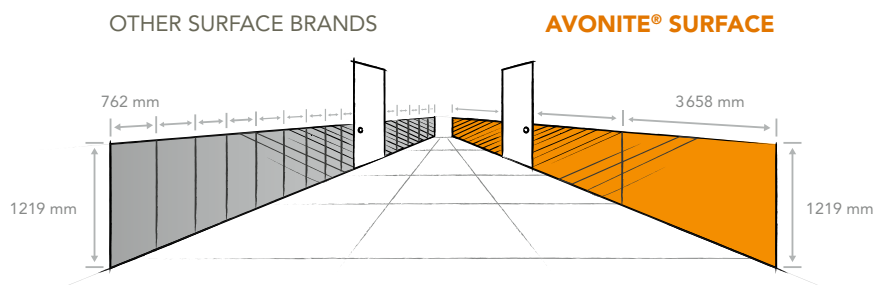

**WIDER SHEETS = TIME SAVED = BIG SAVINGS**



Location: Hanau City Library

Photographer: Julia Schambeck

Fabricator: Rosskopf + Partner AG

Architect: Schrammel Architekten Stadtplaner Part GmbH

## THE ULTIMATE FLEXIBILITY

You can customise the dimensions of your sheets.  
From the simplest format to the most unusual designs, Aristech  
Surfaces LLC offers you an infinitely wide array of options.

*For more information on the requirements, consult your local distributor.*

**2 134 x 686 mm**  
**SHEETS' MINIMUM DIMENSIONS**

### THICKNESS

3 mm

6 mm

9 mm

12 mm

19 mm

**5 182 x 1524 mm**  
**SHEETS' MAXIMUM DIMENSIONS**



## OUR COMMITMENT TO ECOLOGY

---

**WE SEE SUSTAINABILITY AS MORE THAN JUST OFFERING PRODUCTS WITH RECYCLED CONTENT AND REGULATORY COMPLIANCE – IT MEANS HAVING A RESPONSIBILITY TO TOUCH AND IMPROVE LIVES BY MAKING A POSITIVE IMPACT ON OTHERS, NOW AND FOR THE FUTURE.**

---

### **REUSE AND RECYCLE**

At Aristech Surfaces LLC, we continually strive to improve our energy and water efficiency, landfill diversion, and air quality, using performance metrics we measure and report. Recent and ongoing environmental initiatives include conversion to LED lighting at our plants and offices, proactive recycling of office and industrial materials, high-efficiency motor upgrades to machine drives, industrial water filtration and recycling systems and thermal oxidizing units with heat recovery to reduce VOC emissions.

Finally, Aristech Surfaces LLC transport partner for Europe guarantees recycling of waste water, uses solar energy in the warehouse and trucks that run on gas.





## INDOOR ENVIRONMENTAL QUALITY

AVONITE® has been awarded Indoor Advantage Gold by SCS Global Services and earned a score of A+ for the material's adherence to French regulations governing the emission of volatile organic compounds.

## REDUCING WASTE

The **RIGHT SIZE** Programme is another key component of our approach to sustainable design. The possibility of choosing the best format for your projects optimizes the material consumption to suit your needs.

## ENERGY CONSERVATION

Historically, it's not a coincidence if we chose to work with a double-belt continuous cast technology. Equipped with a symmetric heating and cooling system, solvent free and allowing to reduce the waste to the lowest level, this manufacturing technique is one of the eco-friendliest.

Our recent efforts to conserve energy include updating boiler controls and eliminating an inert gas generator at our Belen, New Mexico facility; installing a new nitrogen system, which improved energy efficiency and reduced emissions.

Our Florence, Kentucky site was re-lamped with LED technology, significantly reducing electrical consumption.

Certified leader:



# OUR COLOUR SELECTION

Whether the simple elegance of Altitude, the depth of the Summit, the inimitable texture of Sandstone, the purity of Ice White or the vitality of Mango, AVONITE® offers a colour range balanced between the latest trends and timeless classics.

Depending on the climate, the orientation and the application, AVONITE® recommends 7 colours for outdoor use (highlighted with a Δ hereunder). We predict a UV resistance under ΔE 5 and a gloss loss of less than 40% for a matt finish.

## PRICE GROUP 0



## PRICE GROUP 2



## PRICE GROUP 4



## PRICE GROUP 5

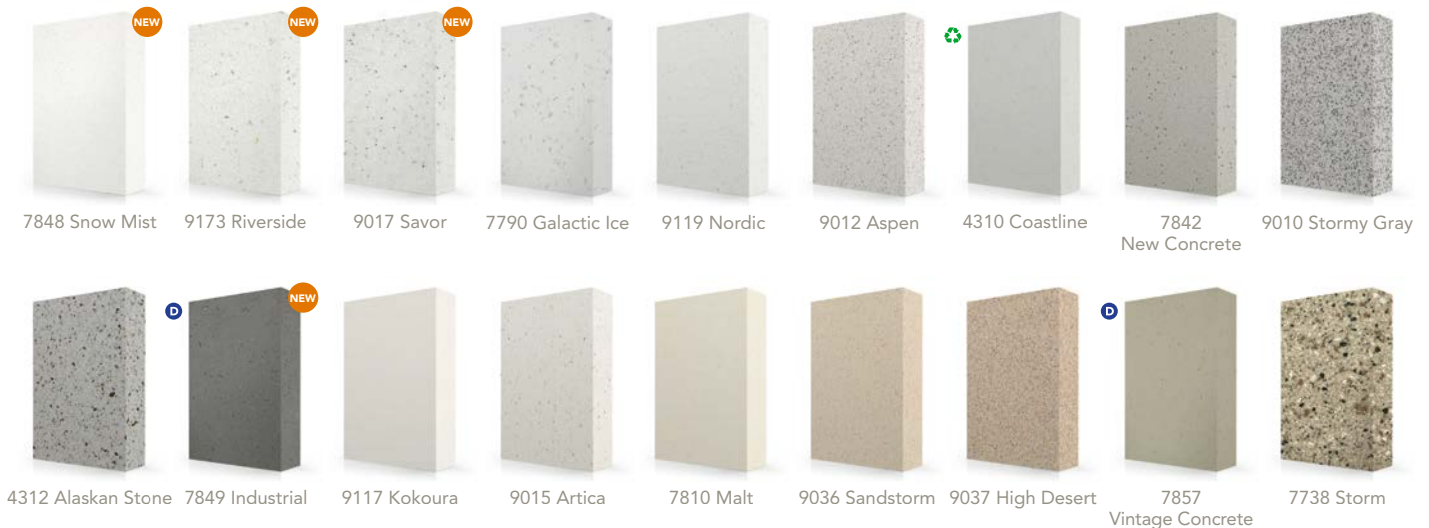

## FOR A 100% AVONITE® LOOK

Our national distributors offer a wide variety of vanities and sinks made of injected or thermoformed Solid Surface. AVONITE® colour-matched sinks and vanities mean disappearing joints and single block counters for enhanced hygiene and aesthetic.

The sink and vanity colours are developed with meticulous care to perfectly match a choice of AVONITE® sheet colour.



Photo: Solits

**OUR BUZZWORD IS FLEXIBILITY. IN JUST TWO WEEKS, WE WILL SEND YOU A SAMPLE, INFORMATION ON THE MINIMUM ORDER QUANTITY AND A QUOTE FOR YOUR PERSONALISED CUSTOM COLOUR. WORKING WITH US IS AS SIMPLE AS THAT.**

PRICE GROUP 3



8064 Ice White 8298 Ice Blue

### HAVE A PROJECT IN PROGRESS?

Request the free colour samples of your choice on [www.aristechsurfaces.com/avonite](http://www.aristechsurfaces.com/avonite) or ask for a visit from an AVONITE® expert.

PRICE GROUP 6



7728 Relic 7502 Avalanche 7501 Moon Crystal 7746 Cloud Burst 9125 Black Coral 7509 Seaside 7724 Creek Rock 7747 Stony Peak 9137 Casablanca

PRICE GROUP 7



4330 Honey Crunch 7710 Gulf Coast 9144 Palermo 7503 Morning Tundra 7506 River's Edge 7735 Dark Roast



8908 Calm 8901 Altitude 8909 Unwind 8904 Morning Mist 8905 Summit 8903 Torrent

The tones shown on this page may differ slightly from the actual colours. To be safe, make your choice based on samples.

△ Recommended colours for outdoor use.

Ⓛ These décors are heavily pigmented colours, and are prone to show scratches, dust, haziness, and ordinary wear and tear more easily than lighter textured décors. Therefore, these décors are not recommended for use in residential and commercial applications that will be subject to heavy use, and/or horizontal application use, and will not be covered under the AVONITE® warranty in relation to claims for scratches of ordinary wear and tear.

♻ Contains Recycled Content  
Colours marked with this acronym include recycled material and may therefore qualify for additional credits as part of the building's LEED accreditation.

# TECHNICAL INFORMATION

## THAT'S NOT ALL...

AVONITE®'s **RIGHT SIZE** Programme offers 18 formats of sheets in ALL our colours\*, subject to a minimum order quantity and a production lead time of six weeks.

To receive a list of our formats and our terms of sale, or for any additional information, please contact us on

[WWW.ARISTECHSURFACES.COM/AVONITE](http://WWW.ARISTECHSURFACES.COM/AVONITE)

*\*With the exception of 8064 Ice White, 8298 Ice Blue, 8901 Altitude, 8903 Torrent, 8904 Morning Mist, 8905 Summit, 8908 Calm and 8909 Unwind.*

## SHEET DIMENSIONS

AVONITE®'s flexibility is based on the 9 formats of sheets that we keep in stock at our European depot.

THICKNESS (mm)	DIMENSIONS (mm)	AVAILABLE COLOURS
3	W. 762 x L. 3658	8091 Snowfall
	W. 1372 x L. 3048	8091 Snowfall
6	W. 762 x L. 3658	8090 Snowfall
	W. 1372 x L. 3048	8090 Snowfall
12	W. 762 x L. 3658	All colours
	W. 914 x L. 3658	8901 Altitude 8903 Torrent 8904 Morning Mist 8905 Summit 8908 Calm 8909 Unwind
	W. 1372 x L. 3658	8064 Ice White 8298 Ice Blue
	W. 1372 x L. 3048	8090 Snowfall
	W. 1520 x L. 3048	8090 Snowfall

*Designers for the new university hospital in Lausanne, Switzerland, has chosen AVONITE® for the surface of the benches in the public spaces.*

**AVONITE® Ivory 8106**

Designer: Belandscape Switzerland

Fabricator: Rosskopf + Partner AG

Photo: Laurent Essig/David Loriot



# CHEMICAL DATASHEET

To determine stain and chemical resistance, chemical reagents are placed on the surface for 16 hours\*. After the 16 hours period, reagents are removed.

## STAIN RESISTANCE

Stain resistance looks at the effect below the surface. The following reagents show no lasting effects on the surface of AVONITE® sheets when tested to the ISFA 2-01 cleanability/stain resistance standard.

- Acetic Acid (10%)
- Acetone
- B-4 Body Conditioner
- Ball Point Ink Pen
- Black Paste Shoe Polish
- Bleach (Household Type)
- Butyl Acetate
- Butyl Alcohol
- Butyl Ether
- Catsup
- Citric Acid (10%)
- Cupra Ammonia
- Dishwasher Detergent (Cascade)
- Dishwashing Liquid
- Distilled Water
- Ethanol
- Ethyl Alcohol (90%)
- Finger Nail Polish Remover
- Gasoline
- Household bleach
- Household Ammonia
- Hydrogen Peroxide
- Hydrogen Peroxide Solution, 3%
- Instant Coff
- Isopropyl Alcohol (90%)
- Lemon Juice
- Lye Solution (1-2%)
- Mercurochrome (2%)
- Methanol
- Methyl Acetate
- Methyl Ethyl Ketone
- Methyl Orange (1%)
- Methyl Red (1%)
- Mineral Oil
- Naphtha
- Olive Oil
- Pencil Lead
- Permanent Marker
- Pig Blood
- Pine Oil
- Povidone Iodine (10%)
- Yellow Mustard
- Sodium Sulfate (10%)
- Soy Sauce
- Sugar (sucrose)
- Toluene
- Tomato Juice
- Trisodium Phosphate (5%)
- Urea (6%)
- Vegetable Oil
- Vinegar
- Wax Crayon
- Wet Pekoe Tea Bag
- Wine
- Xylene
- Zinc Chloride (10%)

## CHEMICAL RESISTANCE

Chemical resistance is a measure of visible surface changes. The following reagents show no lasting effects on the surface of AVONITE® Acrylic Solid Surface sheets.

- Acetic Acid (10%)
- Acetone
- Acridine Orange
- AG Eosin Blue (5%)
- AG Gentian Violet
- Ammonia (10%)
- Ammonium Hydroxide (28%)
- Amyl Acetate
- Amyl Alcohol
- Aromatic Ammonia
- B-4 Body Conditioner
- Ball Point Pen
- Betadine Solution
- Bite Registration Accelerator (2% Eugenol)
- Bite Registration Base
- Black Paste Shoe Polish
- Bleach (Household Type)
- Blood
- Butyl Acetate
- Butyl Alcohol
- Butyl Ether
- Catsup
- Citric Acid (10%)
- Coffee
- Cupra Ammonia
- Dishwashing Liquid (Cascade)
- Dishwashing Liquid (Dawn)
- Distilled Water
- Equalizing Accelerator
- Ethanol
- Ethyl Acetate
- Ethyl Alcohol (90%)
- Nail Polish Remover
- Gasoline
- Hexane
- Household Soaps
- Hydrogen Peroxide
- Hydrogen Peroxide Solution (3%)
- Instant Coffee
- Isopropyl Alcohol (90%)
- Lemon Juice
- Lye Solution (1-2%)
- Mercurochrome (2%)
- Methanol
- Methyl Acetate
- Methyl Ethyl Ketone
- Methyl Orange (1%)
- Methyl Red (1%)
- Mineral Oil
- Naphtha
- Napthalene (Naptha)
- Nitric Acid (6%)
- Olive Oil
- Pencil Lead
- Perchloric Acid
- Permanent Marker Ink
- Picric Acid
- Pig Blood
- Pine Oil
- Povidone Iodine (10%)
- Yellow Mustard
- Salt (Sodium Chloride)
- Silica Dental Cement (liquid)
- Silver Nitrate (10%)
- Soapless Detergents
- Sodium Bisulfate
- Sodium Hydroxide Solution (<10%)
- Sodium Hypochlorite (5%)
- Sodium Sulfate (10%)
- Soy Sauce
- Sugar (Sucrose)
- Tea
- Toluene
- Tomato Juice
- Trisodium Phosphate (5%)
- Urea (6%)
- Uric Acid
- Urine
- Vegetable Oil
- Vinegar
- Wax Crayon
- Wet Pekoe Tea Bag
- Wine
- Xylene
- Zinc Chloride (10%)

The following reagents should not come into contact with AVONITE® sheets for long periods of time. These reagents may cause surface changes on the sheets that are more difficult to remove:

- Bite Registration Mix (50/50)
- Dry-Bond Dental Adhesive
- Eosine Methylene Blue
- Hydrochloric Acid (>20%)
- Nail Polish
- Nitric Acid (>25%)
- Sodium Hydroxide Solution (>25%)
- Sulfuric Acid (>25%)

\*Although the 16 hours period is standard test procedure, it is recommended to remove chemicals as soon as possible, to prevent damage to the surface.





Certified leader:



**European Head Office**  
**ARISTECH SURFACES LLC**

Unit 301 Clerkenwell Workshops,  
27/31 Clerkenwell Close,  
Farringdon, EC1R 0AT, London, UK  
T +44.208.065.5405  
Toll Free (France, Germany and UK Only):  
00800.5263.5263  
info.europe@aristechsurfaces.com

**Global Headquarters**  
**ARISTECH SURFACES LLC**

7350 Empire Drive  
Florence KY 41042  
USA  
T +1.800.354.9858

Find your closest distributor on

**[WWW.ARISTECHSURFACES.COM/AVONITE](http://WWW.ARISTECHSURFACES.COM/AVONITE)**



AVONITE® and Advanc3® are registered trademarks of Aristech Surfaces LLC. All other trademarks and product names are trademarks or registered trademarks of their respective rights owners. The information contained in this brochure is intended to be for information only and can be amended at any time without prior notification © 2019 Aristech Surfaces LLC. All rights reserved.