

TTSPD-R
3-Tier Spice Pulldown

Installation Instructions

Organize Your Kitchen in
11 minutes
or less



hardware
resources

<p>Minimum Opening:</p> <p>13-5/8" min. opening</p>	<p>Included:</p> <p>3-Tier Spice Organizer (x1) Support Arm (x2) Mounting Bracket (x2) 1/2" Wood Screw (x4) Rubber Washer (x8)</p>	<p>Tools Needed:</p> <p>Pencil Phillips Screw Driver Tape Measure (optional)</p>	<p>⚠ Install rubber washers: Install rubber washers at all (8) eight connecting points.</p> <p>Rubber washer (x4)</p> <p>Rubber washer (x4)</p>
--	---	---	--

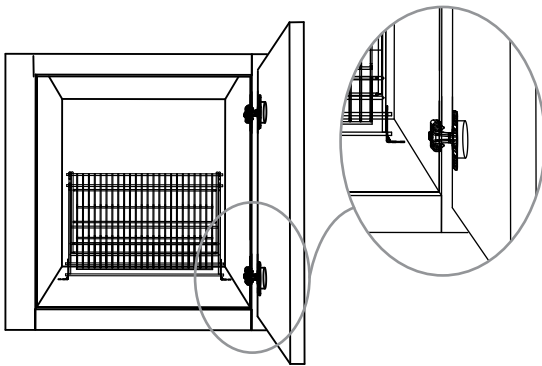

1. Make sure the cabinet hinge will not interfere with organizer when installed

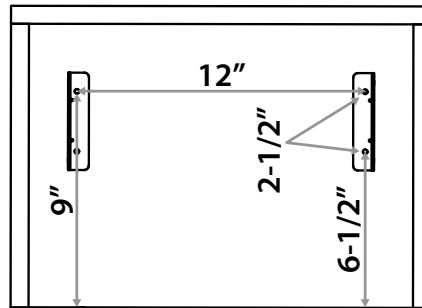

2. Layout and mark measurements for installation. See diagram above.

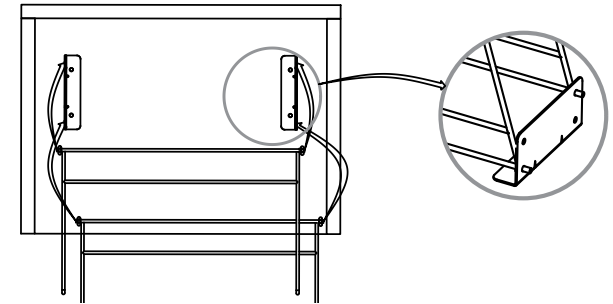

3. Place rear support arm in the rear upper hole of the mounting bracket and place the front support arm in the front lower hole.

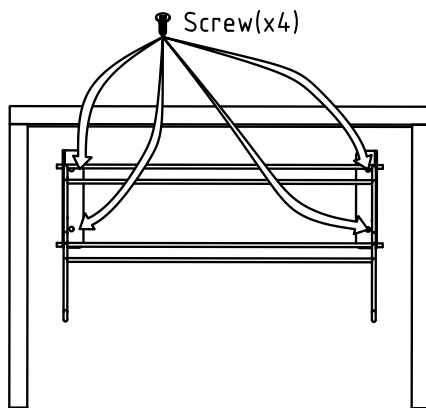

4. Install mounting brackets with (4) four 1/2" wood screws provided.

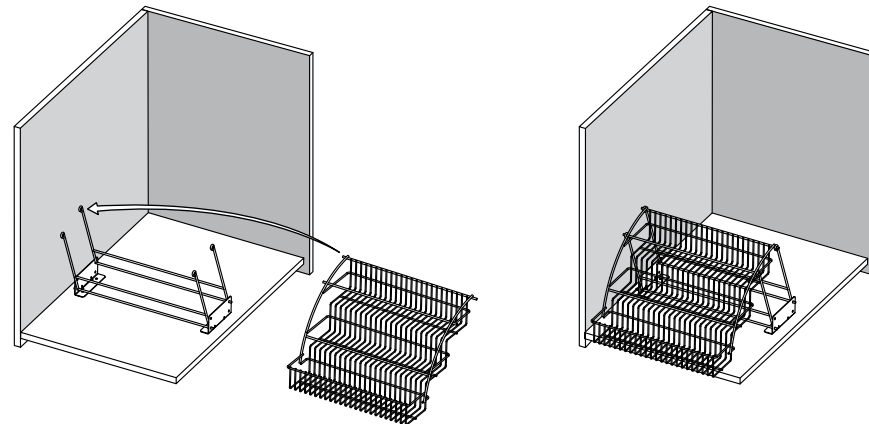

5. Assemble the Spice Pulldown by placing the rear support arm on the rear support peg on each side. Repeat for front support arm.

SCPO-R

Carrito de retiro para suministros de limpieza
Chariot coulissant pour produits nettoyants

ESP: Instrucciones de instalacion FR: Instructions d'installation

Organize Your Kitchen in
11 minutes
or less



hardware
resources

ESP: Abertura mínima
FR: Ouverture minimale

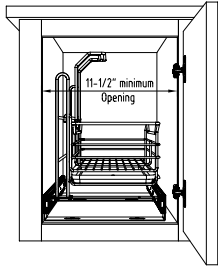

ESP: Incluido
FR: Inclus

 3/4" tornillo (x4)
Vis de 3/4 po (x4)

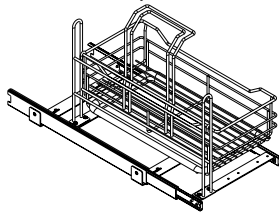

ESP: Herramientas necesarias
FR: Outils nécessaires

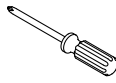
 ESP: destornillador phillips
FR: Tournevis cruciforme (Phillips)

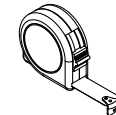
 ESP: cinta métrica (opcional)
FR: Ruban à mesurer (optionnel)

! ESP: Armar el soporte vertical

Utilice los tornillos incluidos para fijar. Se puede instalar para utilización con la mano izquierda o la derecha.

FR: Assembler le support vertical

Fixer au moyen des vis incluses. Peut être installé pour une utilisation à main droite ou à main gauche.

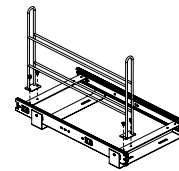

OU

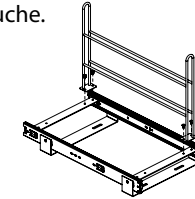

M4 10mm tornillo (x4)
Vis M4 10mm (x4)

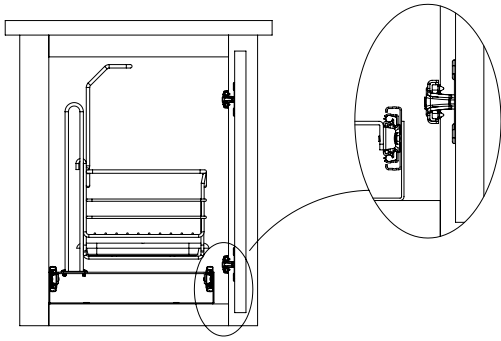

ESP: Asegúrese de que la bisagra del gabinete no interferirá con el organizador cuando se instale.
FR: S'assurer que la charnière de l'armoire ne nuira pas à l'organisateur après l'installation

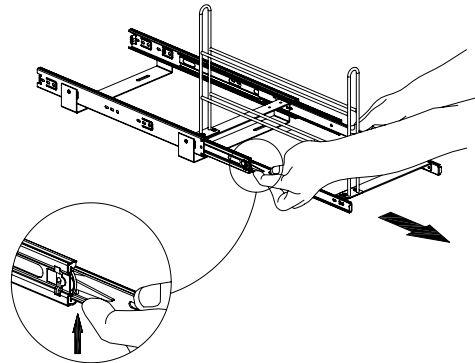

ESP: Libere el riel pulsando el gatillo negro para arriba en el lado izquierdo y abajo en el lado derecho.
FR: Relâcher le chariot en poussant la gâchette noire vers le HAUT sur le côté GAUCHE et vers les BAS sur le côté DROIT

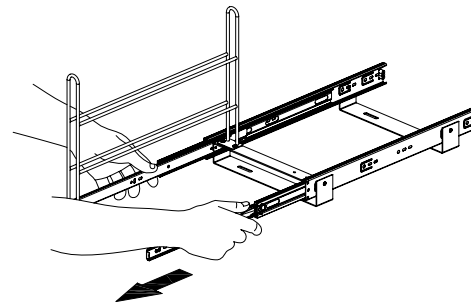

ESP: Quite el organizador del marco del riel jalando hacia al frente.
FR: Retirer l'organisateur du châssis de glissement en tirant vers l'avant

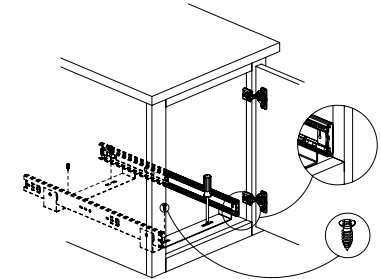

ESP: Alinee la parte delantera del riel con la parte de adentro de los labios del gabinete. Artonille el marco del riel en el gabinete con los cuatro tornillos incluidos.
FR: Aligner le devant du chariot avec la bride intérieure de l'armoire. Visser le châssis de glissement dans l'armoire avec les 4 vis incluses

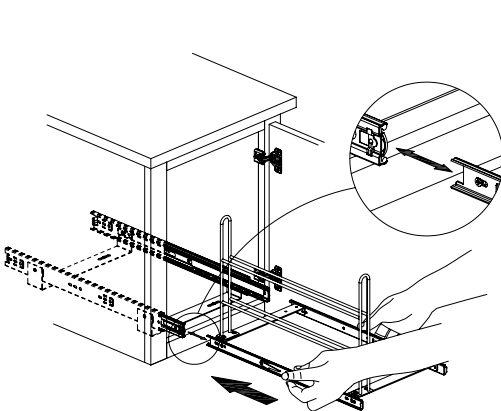

ESP: Alinee y vuelva a insertar organizador en marco del riel.
FR: Aligner et réinsérer l'organisateur dans le châssis coulissant

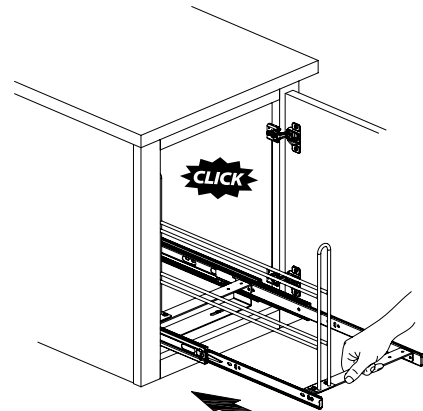

ESP: Empuje el organizador en el marco del riel hasta que "click" en su lugar.
FR: Pousser l'organisateur dans le châssis de glissement jusqu'à ce qu'il S'ENCLENCHE en place

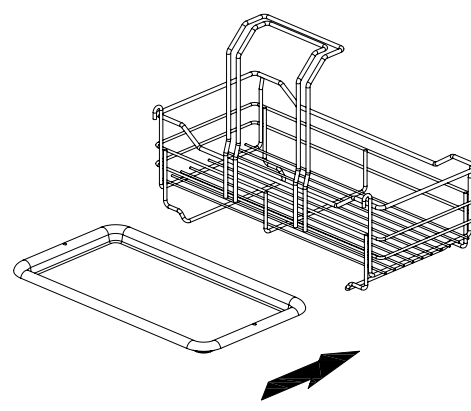

ESP: Pon la bandeja en la parte inferior de la canasta.
FR: Glisser le plateau de plastique pour égouttement dans le bas du chariot

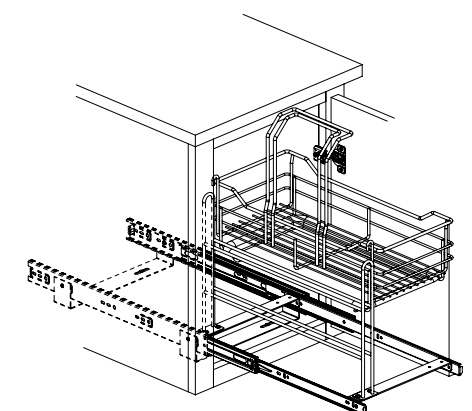

ESP: Cuelgue la canasta en el soporte vertical.
FR: Glisser le plateau de plastique pour égouttement dans le bas du chariot