

ANSI/AISC 303-16  
An American National Standard

---

# Code of Standard Practice for Steel Buildings and Bridges

---

June 15, 2016

Supersedes the *Code of Standard Practice for Steel Buildings and Bridges*  
dated April 14, 2010 and all previous versions

Approved by the Committee on the Code of Standard Practice



**AMERICAN INSTITUTE OF STEEL CONSTRUCTION**  
130 East Randolph Street, Suite 2000, Chicago, Illinois 60601  
[www.aisc.org](http://www.aisc.org)

© AISC 2016

by

American Institute of Steel Construction

*All rights reserved. This book or any part thereof  
must not be reproduced in any form without the  
written permission of the publisher.  
The AISC logo is a registered trademark of AISC.*

The information presented in this publication has been prepared by a balanced committee following American National Standards Institute (ANSI) consensus procedures and recognized principles of design, construction and contract interpretation. This document is intended as a statement of custom and usage in structural steel construction. Competent design, construction and legal advice should be sought when applying the provisions of this document to a specific construction project or contract document. The publication of this information is not a representation or warranty on the part of the American Institute of Steel Construction, its officers, agents, employees or committee members, or of any other person named herein. All representations or warranties, express or implied, other than as stated above, are specifically disclaimed. Anyone making use of the information presented in this publication assumes all liability arising from such use.

Caution must be exercised when relying upon standards and guidelines developed by other bodies and incorporated by reference herein, since such material may be modified or amended from time to time subsequent to the publication of this edition. The American Institute of Steel Construction bears no responsibility for such material other than to refer to it and incorporate it by reference at the time of the initial publication of this edition.

Printed in the United States of America

Revision May 2017

## PREFACE

(This Preface is not part of ANSI/AISC 303-16, but is included for informational purposes only.)

As in any industry, trade practices have developed among those that are involved in the design, purchase, fabrication and erection of structural steel. This Code provides a useful framework for a common understanding of the acceptable standards when contracting for structural steel. As such, it is useful for owners, architects, engineers, general contractors, construction managers, fabricators, steel detailers, erectors and others associated with construction in structural steel. Unless specific provisions to the contrary are contained in the contract documents, the existing trade practices contained herein are considered to be the standard custom and usage of the industry and are thereby incorporated into the relationships between the parties to a contract.

It is important to note the differences in design requirements between buildings and bridges. ANSI/AISC 360 and 341 establish the design requirements for buildings and building-like structures, and this Code sets complementary commercial and technical requirements. For highway bridges, the governing design requirements are established by AASHTO and implemented by the contracting agency; the commercial provisions of the Code are applicable, but technical provisions, such as tolerances, are not addressed.

The Symbols and Glossary are an integral part of this Code. In many sections of this Code, a nonmandatory Commentary has been prepared to provide background and further explanation for the corresponding Code provisions. The user is encouraged to consult it.

This Code is written—and intended to be utilized in practice—as a unified document. Contract documents may supercede individual provisions of the Code as provided in Section 1.1, except when doing so would violate a requirement of the applicable building code.

Since the first edition of this Code was published in 1924, AISC has continuously surveyed the structural steel design community and construction industry to determine standard trade practices. Since then, this Code has been periodically updated to reflect new and changing technology and industry practices.

The 2000 edition was the fifth complete revision of this Code since it was first published. Like the 2005 and 2010 editions, the 2016 edition is not a complete revision but does add important changes and updates. It is the result of the deliberations of a fair and balanced Committee, the membership of which included structural engineers, architects, a code official, a general contractor, fabricators, a steel detailer, erectors, inspectors and an attorney. The following changes have been made in this revision:

- This Code is formally accredited by ANSI as an American National Standard.
- The language throughout the entire Code has been generalized to address contracts that utilize drawings, models, or drawings and models in combination, and Appendix A, which previously addressed models separately, has been eliminated.
- The Commentary in Section 1.1 has been updated to acknowledge that some portions of ANSI/AISC 303 are incorporated into the *International Building Code* through reference to those provisions in ANSI/AISC 360 and 341.
- The list of dates of referenced documents in Section 1.2 has been editorially updated.
- A new Section 1.4 has been added to address responsibility for identifying contract documents; subsequent sections have been renumbered.

- Section 1.10 has increased emphasis that the absence of a tolerance in this Code does not mean that tolerance is zero.
- Section 1.11 has been added to address marking requirements for protected zones in frames designed to meet the requirements of ANSI/AISC 341.
- A reference has been added in the Commentary to Section 2.2 to AISC Design Guide 27 for stainless steel.
- In Section 3.1, two items are added to the list of required information: preset requirements for free ends of cantilevered members and the drawing information required in ANSI/AISC 341.
- Sections 3.1.1 and 3.1.2 have been editorially switched in order. The resulting Section 3.1.2 (formerly Section 3.1.1) also has been improved to better address what is required for bidding when the owner's designated representative for design delegates the determination and design of member reinforcement at connections to the licensed engineer in responsible charge of the connection design.
- Section 3.2 has been updated to address revisions, if they are necessary, when referenced contract documents are not available at the time of design, bidding, detailing or fabrication.
- Section 3.3 has added emphasis that the fabricator need not discover design discrepancies.
- Sections 3.7 and 4.2.2 have been added to address intellectual property rights of the owner's designated representative for design and the fabricator, respectively.
- Section 4.4 has been clarified to better reflect the role of the connection design criteria required in Section 3.1.1 when connection design work is delegated.
- Commentary has been added to Section 4.5 to address potential pitfalls when fabrication and erection documents are not furnished by the fabricator.
- In Section 6.1.1, the listed shop-standard material grades have changed for HP-shapes and HSS.
- In Section 6.4.2, the tolerance for curved members has been improved.
- In Section 7.5.1, tolerances for anchor-rod placement have been revised for consistency with the hole sizes provided the AISC *Steel Construction Manual* and the tolerances given in ACI 117.
- In Section 7.8.3, the number of extra bolts required to be supplied has been increased to account for bolt loss and pre-installation verification testing requirements; also, backing has been clarified as steel backing.
- In Section 7.8.4, non-steel backing is now addressed.
- In Section 7.13, the term "building line" has been changed to "building exterior."
- Commentary has been added in Section 7.13.1.2(e) to coordinate with the cantilevered member preset information added in Section 3.1.
- Section 9.1.5 has been added to address allowances, when used.
- Section 10 has been significantly revised with multiple categories for AESS and different treatments required for each.
- The document has been editorially revised for consistency with current terms and other related documents.

The Committee thanks Jeffrey Dave, Douglas Fitzpatrick, Angela Stephens and Lawrence Kruth for their contributions to integrating treatment of model-based contracts throughout this Code; Walter Koppelaar, Terri Boake and Jack Petersen for their contributions to the update of Section 10; and, George Wendt, Charles Wood, John Rogers and Brian Smith for their contributions to the improvement of tolerances for curved members.

The Committee thanks Michael J. Tylk, Donald G. Moore and Paul M. Brosnahan for their contributions as members of the Committee for part of this cycle, and honors Committee member Keith G. Landwehr, who passed away during this cycle.

By the AISC Committee on the Code of Standard Practice,

Babette C. Freund, Chair

William A. Andrews, Vice Chair

Jon D. Andrews

Scott F. Armbrust

Barry L. Barger, Emeritus

William R. Davidson

Theodore L. Droessler

Donald T. Engler

Lawrence G. Griffis

Samuel G. Haldiman

Timothy J. Hanenburg

D. Kirk Harman

Lawrence A. Kloiber

Viji Kuruvilla

James L. Larson

H. Scott Metzger

James A. Minkinen

David B. Ratterman

David I. Ruby

James A. Stori

Thomas S. Tarp, Jr.

James G. Thompson

Steven F. Weiss

Michael A. West

Charles J. Carter, Secretary

Timothy J. Bradshaw, Asst. Secretary

# TABLE OF CONTENTS

<b>GLOSSARY</b> .....	ix
<b>SECTION 1. GENERAL PROVISIONS</b> .....	1
1.1. Scope .....	1
1.2. Dates of Referenced Specifications, Codes and Standards .....	1
1.3. Units .....	3
1.4. Responsibility for Identifying Contract Documents .....	3
1.5. Design Criteria .....	3
1.6. Responsibility for Design .....	4
1.7. Patents and Copyrights .....	4
1.8. Existing Structures .....	4
1.9. Means, Methods and Safety of Erection .....	4
1.10. Tolerances .....	5
1.11. Marking of Protected Zones in High-Seismic Applications .....	5
<b>SECTION 2. CLASSIFICATION OF MATERIALS</b> .....	6
2.1. Definition of Structural Steel .....	6
2.2. Other Steel, Iron or Metal Items .....	7
<b>SECTION 3. DESIGN DOCUMENTS AND SPECIFICATIONS</b> .....	9
3.1. Structural Design Documents and Specifications .....	9
3.2. Architectural, Electrical and Mechanical Design Documents and Specifications .....	16
3.3. Discrepancies .....	16
3.4. Legibility of the Design Drawings .....	16
3.5. Revisions to the Design Documents and Specifications .....	17
3.6. Fast-Track Project Delivery .....	18
3.7. Intellectual Property .....	18
<b>SECTION 4. APPROVAL DOCUMENTS</b> .....	19
4.1. Owner Responsibility .....	19
4.2. Fabricator Responsibility .....	20
4.3. Use of Digital Files or Copies of the Design Documents .....	21
4.4. Approval .....	23
4.5. Fabrication and/or Erection Documents Not Furnished by the Fabricator .....	25
4.6. The RFI Process .....	25
4.7. Erection Documents .....	26
<b>SECTION 5. MATERIALS</b> .....	27
5.1. Mill Materials .....	27
5.2. Stock Materials .....	28

<b>SECTION 6. SHOP FABRICATION AND DELIVERY</b> .....	30
6.1. Identification of Material .....	30
6.2. Preparation of Material .....	31
6.3. Fitting and Fastening .....	31
6.4. Fabrication Tolerances .....	32
6.5. Shop Cleaning and Painting .....	35
6.6. Marking and Shipping of Materials .....	37
6.7. Delivery of Materials .....	38
<b>SECTION 7. ERECTION</b> .....	39
7.1. Method of Erection .....	39
7.2. Job-Site Conditions .....	39
7.3. Foundations, Piers and Abutments .....	39
7.4. Lines and Benchmarks .....	40
7.5. Installation of Anchor Rods, Foundation Bolts, and Other Embedded Items .....	40
7.6. Installation of Bearing Devices .....	41
7.7. Grouting .....	41
7.8. Field Connection Material .....	42
7.9. Loose Material .....	43
7.10. Temporary Support of Structural Steel Frames .....	43
7.11. Safety Protection .....	46
7.12. Structural Steel Frame Tolerances .....	46
7.13. Erection Tolerances .....	47
7.14. Correction of Errors .....	57
7.15. Cuts, Alterations and Holes for Other Trades .....	57
7.16. Handling and Storage .....	58
7.17. Field Painting .....	58
7.18. Final Cleaning Up .....	58
<b>SECTION 8. QUALITY CONTROL</b> .....	59
8.1. General .....	59
8.2. Inspection of Mill Material .....	59
8.3. Nondestructive Testing .....	60
8.4. Surface Preparation and Shop Painting Inspection .....	60
8.5. Independent Inspection .....	60
<b>SECTION 9. CONTRACTS</b> .....	61
9.1. Types of Contracts .....	61
9.2. Calculation of Weights .....	61
9.3. Revisions to the Contract Documents .....	63
9.4. Contract Price Adjustment .....	63
9.5. Scheduling .....	63
9.6. Terms of Payment .....	64

**SECTION 10. ARCHITECTURALLY EXPOSED STRUCTURAL STEEL . . . . . 65**  
10.1. General Requirements . . . . . 65  
10.2. Contract Documents . . . . . 66  
10.3. Approval Documents . . . . . 66  
10.4. Fabrication . . . . . 68  
10.5. Delivery of Materials . . . . . 69  
10.6. Erection . . . . . 69



## GLOSSARY

The following abbreviations and terms are used in this Code. Where used, terms are italicized to alert the user that the term is defined in this Glossary.

*AASHTO*. American Association of State Highway and Transportation Officials.

*Adjustable items*. See Section 7.13.1.3.

*AESS*. See *architecturally exposed structural steel*.

*AISC*. American Institute of Steel Construction.

*Allowance*. A monetary amount included in a contract as a placeholder for work that is anticipated but not defined at the time the contract is executed.

*Anchor bolt*. See *anchor rod*.

*Anchor rod*. A mechanical device that is either cast or drilled and chemically adhered, grouted or wedged into concrete and/or masonry for the purpose of the subsequent attachment of *structural steel*.

*ANSI*. American National Standards Institute.

*Approval documents*. The *structural steel shop drawings*, *erection drawings*, and *embedment drawings*, or where the parties have agreed in the *contract documents* to provide digital model(s), the *fabrication* and *erection models*. A combination of drawings and digital models also may be provided.

*Architect*. The entity that is professionally qualified and duly licensed to perform architectural services.

*Architecturally exposed structural steel*. See Section 10.

*AREMA*. American Railway Engineering and Maintenance of Way Association.

*ASME*. American Society of Mechanical Engineers.

*ASTM*. American Society for Testing and Materials.

*AWS*. American Welding Society.

*Bearing devices*. Shop-attached base and bearing plates, loose base and bearing plates, and leveling devices, such as leveling plates, leveling nuts and washers, and leveling screws.

*CASE*. Council of American Structural Engineers.

*Clarification.* An interpretation, of the *design drawings* or *specifications* that have been *released for construction*, made in response to an *RFI* or a note on an approval drawing and providing an explanation that neither revises the information that has been *released for construction* nor alters the cost or schedule of performance of the work.

*The Code, This Code.* This document, the *AISC Code of Standard Practice for Steel Buildings and Bridges* as adopted by the American Institute of Steel Construction.

*Column line.* The grid line of column centers set in the field based on the dimensions shown on the structural *design documents* and using the building layout provided by the *owner's designated representative for construction*. Column offsets are taken from the *column line*. The *column line* may be straight or curved as shown in the structural *design documents*.

*Connection.* An assembly of one or more joints that is used to transmit forces between two or more members and/or *connection* elements.

*Contract documents.* The documents that define the responsibilities of the parties that are involved in bidding, fabricating and erecting *structural steel*. These documents normally include the *design documents*, the *specifications* and the contract.

*Design documents.* The *design drawings*, or where the parties have agreed in the *contract documents* to provide digital model(s), the *design model*. A combination of drawings and digital models also may be provided.

*Design drawings.* The graphic and pictorial portions of the *contract documents* showing the design, location and dimensions of the work. These documents generally include, but are not necessarily limited to, plans, elevations, sections, details, schedules, diagrams and notes.

*Design model.* A dimensionally accurate 3D digital model of the structure that conveys the *structural steel* requirements given in Section 3.1 for the building.

*Detailer.* See *steel detailer*.

*Embedment drawings.* Drawings that show the location and placement of items that are installed to receive *structural steel*.

*EOR, engineer, engineer of record.* See *structural engineer of record*.

*Erection bracing drawings.* Drawings that are prepared by the erector to illustrate the sequence of erection, any requirements for temporary supports and the requirements for raising, bolting and/or welding. These drawings are in addition to the *erection drawings*.

*Erection documents.* The *erection drawings*, or where the parties have agreed in the *contract documents* to provide digital model(s), the *erection model*. A combination of drawings and digital models also may be provided.

*Erection drawings.* Field-installation or member-placement drawings that are prepared by the *fabricator* to show the location and attachment of the individual *structural steel* shipping pieces.

*Erection model.* A dimensionally accurate 3D digital model produced to convey the information necessary to erect the *structural steel*. This may be the same digital model as the *fabrication model*, but it is not required to be.

*Erector.* The entity that is responsible for the erection of the *structural steel*.

*Established column line.* The actual field line that is most representative of the erected column centers along a line of columns placed using the dimensions shown in the structural *design drawings* or *design model* and the lines and benchmarks established by the *owner's designated representative for construction*, to be used in applying the erection tolerances given in this Code for column shipping pieces.

*Fabrication documents.* The *shop drawings*, or where the parties have agreed in the *contract documents* to provide digital model(s), the *fabrication model*. A combination of drawings and digital models also may be provided.

*Fabrication model.* A dimensionally accurate 3D digital model produced to convey the information necessary to fabricate the *structural steel*. This may be the same digital model as the *erection model*, but it is not required to be.

*Fabricator.* The entity that is responsible for detailing (except in Section 4.5) and fabricating the *structural steel*.

*Hazardous materials.* Components, compounds or devices that are either encountered during the performance of the contract work or incorporated into it containing substances that, notwithstanding the application of reasonable care, present a threat of harm to persons and/or the environment.

*Inspector.* The *owner's* testing and inspection agency.

*Levels of development, LOD.* The levels of completeness of the digital model(s) or digital model elements.

*MBMA.* Metal Building Manufacturers Association.

*Mill material.* Steel mill products that are ordered expressly for the requirements of a specific project.

*Owner.* The entity that is identified as such in the *contract documents*.

*Owner's designated representative for construction.* The *owner* or the entity that is responsible to the *owner* for the overall construction of the project, including its planning, quality, and completion. This is usually the general contractor, the construction manager or similar authority at the job site.

*Owner's designated representative for design.* The *owner* or the entity that is responsible to the *owner* for the overall structural design of the project, including the *structural steel* frame. This is usually the *structural engineer of record*.

*Plans.* See *design drawings*.

*RCSC.* Research Council on Structural Connections.

*Released for construction.* The term that describes the status of *contract documents* that are in such a condition that the *fabricator* and the *erector* can rely upon them for the performance of their work, including the ordering of material and the preparation of *shop* and *erection drawings* or *fabrication* and *erection models*.

*Revision.* An instruction or directive providing information that differs from information that has been *released for construction*. A *revision* may, but does not always, impact the cost or schedule of performance of the work.

*RFI.* A written request for information or *clarification* generated during the construction phase of the project.

*SER.* See *structural engineer of record*.

*Shop drawings.* Drawings of the individual *structural steel* shipping pieces that are to be produced in the fabrication shop.

*SJI.* Steel Joist Institute.

*Specifications.* The portion of the *contract documents* that consists of the written requirements for materials, standards and workmanship.

*SSPC.* SSPC: The Society for Protective Coatings, which was formerly known as the Steel Structures Painting Council.

*Standard structural shapes.* Hot-rolled W-, S-, M- and HP-shapes, channels and angles listed in ASTM A6/A6M; structural tees split from the hot-rolled W-, S- and M- shapes listed in ASTM A6/A6M; hollow structural sections produced to ASTM A500/A500M, A501/A501M, A618/A618M, A847/A847M, A1065/A1065M, or A1085/A1085M; and, steel pipe produced to ASTM A53/A53M.

*Steel detailer.* The entity that produces the *approval documents*.

*Structural engineer of record.* The licensed professional who is responsible for sealing the *contract documents*, which indicates that he or she has performed or supervised the analysis, design and document preparation for the structure and has knowledge of the load-carrying structural system.

*Structural steel.* The elements of the structural frame as given in Section 2.1.

*Substantiating connection information.* Information submitted by the *fabricator*, if requested by the *owner's designated representative for design* in the *contract documents*, when Option 2 or Option 3 is designated for *connections* per Section 3.1.1.

*Tier.* The *structural steel* framing defined by a column shipping piece.

*Weld show-through.* In *architecturally exposed structural steel*, visual indication of the presence of a weld or welds on the side of the member opposite the weld.

# CODE OF STANDARD PRACTICE FOR STEEL BUILDINGS AND BRIDGES

## SECTION 1. GENERAL PROVISIONS

### 1.1. Scope

This Code sets forth criteria for the trade practices involved in steel buildings, bridges and other structures, where other structures are defined as those structures designed, fabricated and erected in a manner similar to buildings, with building-like vertical and lateral force-resisting elements. In the absence of specific instructions to the contrary in the *contract documents*, the trade practices that are defined in this Code shall govern the fabrication and erection of *structural steel*.

#### Commentary:

The practices defined in this Code are the commonly accepted standards of custom and usage for *structural steel* fabrication and erection, which generally represent the most efficient approach. Some provisions in this Code have been incorporated by reference into the International Building Code; see [www.aisc.org/303IBC](http://www.aisc.org/303IBC).

This Code is not intended to define a professional standard of care for the *owner's designated representative for design*; change the duties and responsibilities of the *owner*, contractor, *architect* or *structural engineer of record* from those set forth in the *contract documents*; nor assign to the *owner*, *architect* or *structural engineer of record* any duty or authority to undertake responsibility inconsistent with the provisions of the *contract documents*.

This Code is not applicable to steel joists or metal building systems, which are addressed by SJI and MBMA, respectively.

### 1.2. Dates of Referenced Specifications, Codes and Standards

The following dated versions of documents are referenced in this Code:

AASHTO Specification—2014 AASHTO *LRFD Bridge Design Specifications*, 7<sup>th</sup> Edition, with 2015 and 2016 Interim Revisions.

ANSI/AISC 341—ANSI/AISC 341-16, *AISC Seismic Provisions for Structural Steel Buildings*.

ANSI/AISC 360—ANSI/AISC 360-16, *AISC Specification for Structural Steel Buildings*.

ASME B46.1—ASME B46.1-09, Surface Texture (Surface Roughness, Waviness, and Lay).

AREMA Specification—2015 AREMA *Manual for Railway Engineering, Volume II—Structures, Chapter 15*.

- ASTM A6/A6M-14, *Standard Specification for General Requirements for Rolled Structural Steel Bars, Plates, Shapes, and Sheet Piling.*
- ASTM A36/A36M-14, *Standard Specification for Carbon Structural Steel.*
- ASTM A53/A53M-12, *Standard Specification for Pipe, Steel, Black and Hot-Dipped, Zinc-Coated, Welded and Seamless.*
- ASTM A500/A500M-13, *Standard Specification for Cold-Formed Welded and Seamless Carbon Steel Structural Tubing in Rounds and Shapes.*
- ASTM A501/A501M-14, *Standard Specification for Hot-Formed Welded and Seamless Carbon Steel Structural Tubing.*
- ASTM A572/A572M-15, *Standard Specification for High-Strength Low-Alloy Columbium-Vanadium Structural Steel.*
- ASTM A618/A618M-04(2015), *Standard Specification for Hot-Formed Welded and Seamless High-Strength Low-Alloy Structural Tubing.*
- ASTM A847/A847M-14, *Standard Specification for Cold-Formed Welded and Seamless High-Strength, Low-Alloy Structural Tubing with Improved Atmospheric Corrosion Resistance.*
- ASTM A992/A992M-11(2015), *Standard Specification for Structural Steel Shapes.*
- ASTM A1065/A1065M-15, *Standard Specification for Cold-Formed Electric-Fusion (Arc) Welded High-Strength Low-Alloy Structural Tubing in Shapes, with 50 ksi [345 MPa] Minimum Yield Point.*
- ASTM A1085/A1085M-15, *Standard Specification for Cold-Formed Welded Carbon Steel Hollow Structural Sections (HSS).*
- AWS D1.1/D1.1M—AWS D1.1/D1.1M:2015 *Structural Welding Code—Steel.*
- RCSC Specification—*Specification for Structural Joints Using High-Strength Bolts*, 2014.
- SSPC SP1—*SSPC Surface Preparation Specification No. 1, Solvent Cleaning*, 2015.
- SSPC SP2—*SSPC Surface Preparation Specification No. 2, Hand Tool Cleaning*, 2004.
- SSPC SP6—*SSPC Surface Preparation Specification No. 6, Commercial Blast Cleaning*, 2007.

**Commentary:**

Additionally, the following dated versions of documents are referenced in the Commentary on this Code:

- AIA Document E202—2008 Building Information Modeling Protocol Exhibit
- AIA Document E203—2013 Building Information Modeling and Digital Data Exhibit
- AIA Document G201—2013 Project Digital Data Protocol Form
- AIA Document G202—2013 Project Building Information Modeling Protocol Form
- ASTM A563-15, *Standard Specification for Carbon and Alloy Steel Nuts.*
- ASTM A563M-07(2013), *Standard Specification for Carbon and Alloy Steel Nuts (Metric).*
- ASTM F3125/F3125M-15, *Standard Specification for High Strength Structural Bolts, Steel and Alloy Steel, Heat Treated, 120 ksi (830 MPa) and 150 ksi (1040 MPa) Minimum Tensile Strength, Inch and Metric Dimensions.*

BIMFORUM 2013 Level of Development Specification.  
CASE Document 962—*National Practice Guidelines for the Structural Engineer of Record, 2012*.  
Consensus Docs 301—2013 BIM Addendum.

### 1.3. Units

In this Code, the values stated in either U.S. customary units or metric units shall be used. Each system shall be used independently of the other.

#### **Commentary:**

In this Code, dimensions, weights and other measures are given in U.S. customary units with rounded or rationalized metric-unit equivalents in brackets. Because the values stated in each system are not exact equivalents, the selective combination of values from each of the two systems is not permitted.

### 1.4 Responsibility for Identifying Contract Documents

The *owner's designated representative for construction* shall identify all *contract documents*. When the *design drawings* and a *design model* are both provided, the *owner's designated representative for design* shall specify which document is the controlling *contract document*. The *contract documents* shall establish the procedures for communicating changes to the *contract documents*, permitted use of design and other digital models, and restrictions on the release of these digital models to other parties.

#### **Commentary:**

There can be many combinations of drawings and digital models used as part of the *contract documents*, and to transfer information between the many entities in the design and construction processes. The communication of design information to the *fabricator* through the *design model* is permitted in this Code. This Code does not designate which of these possible documents takes precedence because of the variation in current practice. The document hierarchy is left to the *owner's designated representative for design* and communicated through the *owner's designated representative for construction*. The *owner's designated representative for construction* must provide guidance as to which information is to be considered to have precedence if conflicts exist.

### 1.5. Design Criteria

For buildings and other structures, in the absence of other design criteria, the provisions in ANSI/AISC 360 shall govern the design of the *structural steel*. For bridges, in the absence of other design criteria, the provisions in the AASHTO Specification and AREMA Specification shall govern the design of the *structural steel*, as applicable.

## 1.6. Responsibility for Design

- 1.6.1. When the *owner's designated representative for design* provides the design, *design documents* and *specifications*, the *fabricator* and the *erector* are not responsible for the suitability, adequacy or building-code conformance of the design.
- 1.6.2. When the *owner* enters into a direct contract with the *fabricator* to both design and fabricate an entire, completed steel structure, the *fabricator* shall be responsible for the suitability, adequacy, conformance with *owner-established performance criteria*, and building-code conformance of the *structural steel* design. The owner shall be responsible for the suitability, adequacy and building-code conformance of the non-*structural steel* elements and shall establish the performance criteria for the *structural steel* frame.

## 1.7. Patents and Copyrights

The entity or entities that are responsible for the specification and/or selection of proprietary structural designs shall secure all intellectual property rights necessary for the use of those designs.

## 1.8. Existing Structures

- 1.8.1. Demolition and shoring of any part of an existing structure are not within the scope of work that is provided by either the *fabricator* or the *erector*. Such demolition and shoring shall be performed in a timely manner so as not to interfere with or delay the work of the *fabricator* or the *erector*.
- 1.8.2. Protection of an existing structure and its contents and equipment, so as to prevent damage from normal erection processes, is not within the scope of work that is provided by either the *fabricator* or the *erector*. Such protection shall be performed in a timely manner so as not to interfere with or delay the work of the *fabricator* or the *erector*.
- 1.8.3. Surveying or field dimensioning of an existing structure is not within the scope of work that is provided by either the *fabricator* or the *erector*. Such surveying or field dimensioning, which is necessary for the completion of the *approval documents* and fabrication, shall be performed and furnished to the *fabricator* in a timely manner so as not to interfere with or delay the work of the *fabricator* or the *erector*.
- 1.8.4. Abatement or removal of *hazardous materials* is not within the scope of work that is provided by either the *fabricator* or the *erector*. Such abatement or removal shall be performed in a timely manner so as not to interfere with or delay the work of the *fabricator* or the *erector*.

## 1.9. Means, Methods and Safety of Erection

- 1.9.1. The *erector* shall be responsible for the means, methods and safety of erection of the *structural steel* frame.



- 1.9.2. The *structural engineer of record* shall be responsible for the structural adequacy of the design of the structure in the completed project. The *structural engineer of record* shall not be responsible for the means, methods and safety of erection of the *structural steel* frame. See also Sections 3.1.4 and 7.10.

### 1.10. Tolerances

Tolerances for materials, fabrication and erection shall be as stipulated in Sections 5, 6, 7 and 10. Tolerances absent from this Code or the *contract documents* shall not be considered zero by default.

#### **Commentary:**

Tolerances are not necessarily specified in this Code for every possible variation that could be encountered. For most projects, where a tolerance is not specified or covered in this Code, it is not needed to ensure that the fabricated and erected *structural steel* complies with the requirements in Section 6 and 7. If a special design concept or system component requires a tolerance that is not specified in this Code, the necessary tolerance should be specified in the *contract documents*. If a tolerance is not shown and is deemed by the *fabricator* and/or *erector* to be important to the successful fabrication and erection of the structural steel, it should be requested from the *owner's designated representative for design*. The absence of a tolerance in this Code for a particular condition does not mean that the tolerance is zero; rather, it means that no tolerance has been established. In any case, the default tolerance is not zero.

### 1.11. Marking of Protected Zones in High-Seismic Applications

The *fabricator* shall permanently mark protected zones that are designated on the structural *design documents* in accordance with ANSI/AISC 341 Section A4.1. If these markings are obscured in the field, such as after the application of fire protection, the *owner's designated representative for construction* shall re-mark the protected zones as they are designated on the structural *design documents*.

## SECTION 2. CLASSIFICATION OF MATERIALS

### 2.1. Definition of Structural Steel

*Structural steel* shall consist of the elements of the structural frame that are shown and sized in the structural *design documents*, essential to support the design loads and described as:

*Anchor rods* that will receive *structural steel*.

Base plates, if part of the *structural steel* frame.

Beams, including built-up beams, if made from *standard structural shapes* and/or plates.

Bearing plates, if part of the *structural steel* frame.

Bearings of steel for girders, trusses or bridges.

Bracing, if permanent.

Canopy framing, if made from *standard structural shapes* and/or plates.

Columns, including built-up columns, if made from *standard structural shapes* and/or plates.

*Connection* materials for framing *structural steel* to *structural steel*.

Crane stops, if made from *standard structural shapes* and/or plates.

Door frames, if made from *standard structural shapes* and/or plates and if part of the *structural steel* frame.

Edge angles and plates, if attached to the *structural steel* frame or steel (open-web) joists.

Embedded *structural steel* parts, other than bearing plates, that will receive *structural steel*.

Expansion joints, if attached to the *structural steel* frame.

Fasteners for connecting *structural steel* items: permanent shop bolts, nuts and washers; shop bolts, nuts and washers for shipment; field bolts, nuts and washers for permanent *connections*; and, permanent pins.

Floor-opening frames, if made from *standard structural shapes* and/or plates and attached to the *structural steel* frame or steel (open-web) joists.

Floor plates (checkered or plain), if attached to the *structural steel* frame.

Girders, including built-up girders, if made from *standard structural shapes* and/or plates.

Girts, if made from *standard structural shapes*.

Grillage beams and girders.

Hangers, if made from *standard structural shapes*, plates and/or rods and framing *structural steel* to *structural steel*.

Leveling nuts and washers.

Leveling plates.

Leveling screws.

Lintels, if attached to the *structural steel* frame.

Marquee framing, if made from *standard structural shapes* and/or plates.

Machinery supports, if made from *standard structural shapes* and/or plates and attached to the *structural steel* frame.

Monorail elements, if made from *standard structural shapes* and/or plates and attached to the *structural steel* frame.

Posts, if part of the *structural steel* frame.  
Purlins, if made from *standard structural shapes*.  
Relieving angles, if attached to the *structural steel* frame.  
Roof-opening frames, if made from *standard structural shapes* and/or plates and attached to the *structural steel* frame or steel (open-web) joists.  
Roof-screen support frames, if made from *standard structural shapes*.  
Sag rods, if part of the *structural steel* frame and connecting *structural steel* to *structural steel*.  
Shear stud connectors, if specified to be shop attached.  
Shims, if permanent.  
Struts, if permanent and part of the *structural steel* frame.  
Tie rods, if part of the *structural steel* frame.  
Trusses, if made from *standard structural shapes* and/or built-up members.  
Wall-opening frames, if made from *standard structural shapes* and/or plates and attached to the *structural steel* frame.  
Wedges, if permanent.

**Commentary:**

The *fabricator* normally fabricates the items listed in Section 2.1. Such items must be shown, sized and described in the structural *design documents*. Bracing includes vertical bracing for resistance to wind and seismic load and structural stability, horizontal bracing for floor and roof systems, and permanent stability bracing for components of the *structural steel* frame.

## 2.2. Other Steel, Iron or Metal Items

*Structural steel* shall not include other steel, iron or metal items that are not generally described in Section 2.1, even where such items are shown in the structural *design documents* or are attached to the *structural steel* frame. Other steel, iron or metal items include but are not limited to:

Base plates, if not part of the *structural steel* frame.  
Bearing plates, if not part of the *structural steel* frame.  
Bearings, if non-steel.  
Cables for permanent bracing or suspension systems.  
Castings.  
Catwalks.  
Chutes.  
Cold-formed steel products.  
Cold-rolled steel products, except those that are specifically covered in ANSI/AISC 360.  
Corner guards.  
Crane rails, splices, bolts and clamps.  
Crane stops, if not made from *standard structural shapes* or plates.  
Door guards.  
Embedded steel parts, other than bearing plates, that do not receive *structural steel* or that are embedded in precast concrete.  
Expansion joints, if not attached to the *structural steel* frame.

Flagpole support steel.

Floor plates (checkered or plain), if not attached to the *structural steel* frame.

Forgings.

Gage-metal products.

Grating.

Handrail.

Hangers, if not made from *standard structural shapes*, plates and/or rods or not framing *structural steel* to *structural steel*.

Hoppers.

Items that are required for the assembly or erection of materials that are furnished by trades other than the *fabricator* or *erector*.

Ladders.

Lintels, if not attached to the *structural steel* frame.

Masonry anchors.

Ornamental metal framing.

Other miscellaneous metal not already listed.

Pressure vessels.

Reinforcing steel for concrete or masonry.

Relieving angles, if not attached to the *structural steel* frame.

Roof screen support frames, if not made from *standard structural shapes*.

Safety cages.

Shear stud connectors, if specified to be field installed.

Stacks.

Stairs.

Steel deck.

Steel (open-web) joists.

Steel joist girders.

Tanks.

Toe plates.

Trench or pit covers.

### **Commentary:**

Section 2.2 includes many items that may be furnished by the *fabricator* if contracted to do so by specific notation and detail in the *contract documents*. When such items are contracted to be provided by the *fabricator*, coordination will normally be required between the *fabricator* and other material suppliers and trades. The provisions in this Code are not intended to apply to items in Section 2.2.

In previous editions of this Code, provisions regarding who should normally furnish field-installed shear stud connectors and cold-formed steel deck support angles were included in Section 7.8. These provisions have been eliminated since field-installed shear stud connectors and steel deck support angles are not defined as *structural steel* in this Code.

Stainless steel is not covered in this Code. AISC Design Guide 27, *Structural Stainless Steel*, is a source of useful information regarding the practical fabrication and installation issues associated with structural stainless steel components.

## SECTION 3. DESIGN DOCUMENTS AND SPECIFICATIONS

### 3.1. Structural Design Documents and Specifications

Unless otherwise indicated in the *contract documents*, the structural *design documents* shall be based upon consideration of the design loads and forces to be resisted by the *structural steel* frame in the completed project.

The structural *design documents* shall clearly show or note the work that is to be performed and shall give the following information with sufficient dimensions to accurately convey the quantity and complexity of the *structural steel* to be fabricated:

- (a) The size, section, material grade and location of all members.
- (b) All geometry and working points necessary for layout.
- (c) Floor elevations.
- (d) Column centers and offsets.
- (e) The camber requirements for members.
- (f) Preset elevation requirements, if any, at free ends of cantilevered members relative to their fixed-end elevations.
- (g) Joining requirements between elements of built-up members.
- (h) When the requirements of ANSI/AISC 341 are applicable, the information required in ANSI/AISC 341 Section A4.
- (i) The information required in Sections 3.1.1 through 3.1.6.

The *structural steel specifications* shall include any special requirements for the fabrication and erection of the *structural steel*.

The structural *design documents*, *specifications* and addenda shall be numbered and dated for the purposes of identification. 3D digital models shall contain a unique identifier.

#### **Commentary:**

*Contract documents* vary greatly in complexity and completeness. Nonetheless, the *fabricator* and the *erector* must be able to rely upon the accuracy and completeness of the *contract documents*. This allows the *fabricator* and the *erector* to provide the *owner* with bids that are adequate and complete. It also enables the preparation of the *approval documents*, the ordering of materials, and the timely fabrication and erection of shipping pieces.

In some cases, the *owner* can benefit when reasonable latitude is allowed in the *contract documents* for alternatives that can reduce cost without compromising quality. However, critical requirements that are necessary to protect the *owner's* interest, that affect the integrity of the structure or that are necessary for the *fabricator* and the *erector* to proceed with their work must be included in the *contract documents*. Some examples of critical information may include, when applicable:

Standard specifications and codes that govern *structural steel* design and construction, including bolting and welding.

Material specifications.

Special material requirements to be reported on the material test reports.

Welded-joint configuration.

Weld-procedure qualification.  
 Special requirements for work of other trades.  
 Final disposition of backing and runoff tabs.  
 Lateral bracing.  
 Stability bracing.  
*Connections* or data for *connection* selection and/or completion.  
 Restrictions on *connection* types.  
 Column stiffeners (also known as continuity plates).  
 Column web doubler plates.  
 Bearing stiffeners on beams and girders.  
 Web reinforcement.  
 Openings for other trades.  
 Surface preparation and shop painting requirements.  
 Shop and field inspection requirements.  
 Nondestructive testing requirements, including acceptance criteria.  
 Special requirements on delivery.  
 Special erection limitations.  
 Identification of non-*structural steel* elements that interact with the *structural steel* frame to provide for the lateral stability of the *structural steel* frame (see Section 3.1.4).  
 Column differential shortening information (see Commentary to Section 7.13).  
 Anticipated deflections and the associated loading conditions for major structural elements, such as transfer girders and trusses, supporting columns and hangers (see Commentary to Section 7.13).  
 Special fabrication and erection tolerances for *AESS*.  
 Special pay-weight provisions.

It may be necessary to specify a relative elevation to which the free end of a cantilever must be erected (preset) prior to load application, with the fixed end stabilized before the member is released from the crane or temporary support and any other load is applied to it. This is needed so that the cantilevered member can be detailed and fabricated to allow for any required preset. This does not apply to a beam that is continuous over a support, which is controlled by camber, not preset.

3.1.1. The *owner's designated representative for design* shall indicate one of the following options for each *connection*:

- (1) Option 1: the complete *connection* design shall be shown in the structural *design documents*.
- (2) Option 2: in the structural *design documents* or *specifications*, the *connection* shall be designated to be selected or completed by an experienced *steel detailer*.
- (3) Option 3: in the structural *design documents* or *specifications*, the *connection* shall be designated to be designed by a licensed engineer working for the *fabricator*.

In all of the above options,

- (a) The requirements of Section 3.1.2 shall apply.
- (b) The approvals process in Section 4.4 shall be followed.

When Option 2 is specified, the experienced *steel detailer* shall utilize information provided in the structural *design documents* in the selection or completion of the *connections*. When such information is not provided, tables in the AISC *Steel Construction Manual*, or other reference information as approved by the *owner's designated representative for design*, shall be used.

When Option 2 or 3 is specified, the *owner's designated representative for design* shall provide the following *connection* design criteria in the structural *design documents* and *specifications*:

- (a) Any restrictions on the types of *connections* that are permitted.
- (b) Data concerning the loads, including shears, moments, axial forces and transfer forces, that are to be resisted by the individual members and their *connections*, sufficient to allow the selection, completion, or design of the *connection* details while preparing the *approval documents*.
- (c) Whether the data required in (b) is given at the service-load level or the factored-load level.
- (d) Whether LRFD or ASD is to be used in the selection, completion, or design of *connection* details.
- (e) What *substantiating connection information*, if any, is to be provided with the *approval documents* to the *owner's designated representative for design*.

When Option 3 is specified:

- (a) The *fabricator* shall submit in a timely manner representative samples of the required *substantiating connection information* to the *owner's designated representatives for design and construction*. The *owner's designated representative for design* shall confirm in writing in a timely manner that these representative samples are consistent with the requirements in the *contract documents*, or shall advise what modifications are required to bring the representative samples into compliance with the requirements in the *contract documents*. This initial submittal and review is in addition to the requirements in Section 4.4.
- (b) The licensed engineer in responsible charge of the *connection* design shall review and confirm in writing as part of the *substantiating connection information*, that the *approval documents* properly incorporate the *connection* designs. However, this review by the licensed engineer in responsible charge of the *connection* design does not replace the approval process of the *approval documents* by the *owner's designated representative for design* in Section 4.4.
- (c) The *fabricator* shall provide a means by which the *substantiating connection information* is referenced to the related *connections* on the *approval documents* for the purpose of review.

#### **Commentary:**

There are three options covered in this Section:

- (1) In Option 1, the *owner's designated representative for design* shows the complete design of the *connections* in the structural *design documents*. The following information is included:

- (a) All weld types, sizes, lengths and strengths.
- (b) All bolt sizes, locations, quantities and grades.
- (c) All plate and angle sizes, thicknesses, dimensions and grades.
- (d) All work point locations and related information.

The intent of this approach is that complete design information necessary for detailing the *connection* is shown in the structural *design documents*. Typical details are shown for each *connection* type, set of geometric parameters, and adjacent framing conditions. The *steel detailer* will then be able to transfer this information to the *approval documents*, applying it to the individual pieces being detailed.

- (2) In Option 2, the *owner's designated representative for design* allows an experienced *steel detailer* to select or complete the *connections*. This is commonly done by referring to loads embedded in the digital model, tables or schematic information in the structural *design documents*, tables in the *AISC Steel Construction Manual*, or other reference information approved by the *owner's designated representative for design*, such as journal papers and recognized software output. Tables and schematic information in the structural *design documents* should provide such information as weld types and sizes, plate thicknesses, and quantities of bolts. However, there may be some geometry and dimensional information that the *steel detailer* must develop. The *steel detailer* will then configure the connections based upon the design loads and other information given in the structural *design documents* and *specifications*.

The intent of this method is that the *steel detailer* will select the *connection* materials and configuration from the referenced tables or complete the specific *connection* configuration (e.g., dimensions, edge distances and bolt spacing) based upon the *connection* details that are shown in the structural *design documents*.

The *steel detailer* must be experienced and familiar with AISC requirements for *connection* configurations, the use of the *connection* tables in the *AISC Steel Construction Manual*, the calculation of dimensions, and adaptation of typical *connection* details to similar situations. Notations of loadings in the structural *design documents* are only to facilitate selection of the *connections* from the referenced tables. It is not the intent that this method be used when the practice of engineering is required.

- (3) Option 3 reflects a practice in some areas of the U.S. to have a licensed engineer working for or retained by the *fabricator* design the *connections*, and recognizes the information required by the *fabricator* to do this work. The *owner's designated representative for design*, who has the knowledge of the structure as a whole, must review and approve the *approval documents*, and take such action on *substantiating connection information* as the *owner's designated representative for design* deems appropriate. See Section 4.4 for the approval process.

When, under Section 3.1.1, the *owner's designated representative for design* designates that *connections* are to be designed by a licensed engineer



employed or retained by the *fabricator*, this work is incidental to, and part of, the overall means and methods of fabricating and constructing the steel frame. The licensed engineer performing the *connection* design is not providing a peer review of the *contract documents*.

The *owner's designated representative for design* reviews the *approval documents* during the approvals process as specified in Section 4.4 for conformance with the specified criteria and compatibility with the design of the primary structure.

One of these options should be indicated for each *connection* in a project. It is acceptable to group *connection* types and utilize a combination of these options for the various *connection* types involved in a project. Option 3 is not normally specified for *connections* that can be selected or completed as noted in Option 2 without practicing engineering.

If there are any restrictions as to the types of *connections* to be used, it is required that these limitations be set forth in the structural *design documents* and *specifications*. There are a variety of *connections* available in the AISC *Steel Construction Manual* for a given situation. Preference for a particular type will vary between *fabricators* and *erectors*. Stating these limitations, if any, in the structural *design documents* and *specifications* will help to avoid repeated changes to the *approval documents* due to the selection of a *connection* that is not acceptable to the *owner's designated representative for design*, thereby avoiding additional cost and/or delay for revising the *approval documents*.

The structural *design documents* must indicate the method of design used as LRFD or ASD. In order to conform to the spirit of ANSI/AISC 360, the *connections* must be selected using the same method and the corresponding references.

*Substantiating connection information*, when required, can take many forms. When Option 2 is designated, the *approval documents* may suffice with no additional *substantiating connection information* required. When Option 3 is designated, the *substantiating connection information* may take the form of hand calculations and/or software output.

When *substantiating connection information* is required, it is recommended that representative samples of that information be agreed upon prior to preparation of the *approval documents*, in order to avoid additional cost and/or delay for the *connection* redesign and/or revising that might otherwise result.

The *owner's designated representative for design* may require that the *substantiating connection information* be signed and sealed for Option 3. The signing and sealing of the cover letter transmitting the *approval documents* and *substantiating connection information* may suffice. This signing and sealing indicates that a licensed engineer performed the work but does not replace the approval process provided in Section 4.4.

A requirement to sign and seal each sheet of the *shop and erection drawings* is discouraged as it may serve to confuse the design responsibility between the *owner's designated representative for design* and the licensed engineer's work in performing the *connection* design. Such a requirement may not be possible when submitting *fabrication and erection models*.

3.1.2. Permanent bracing, openings in structural steel for other trades, and other special details, where required, shall be designed by the *owner's designated representative for design* and shown in sufficient detail in the structural *design documents* issued for bidding so that the quantity, detailing and fabrication requirements for these items can be readily understood.

At locations away from *connections*, stiffeners, web doubler plates, bearing stiffeners, and other member reinforcement, where required, shall be designed by the *owner's designated representative for design* and shown in sufficient detail in the structural *design documents* issued for bidding so that the quantity, detailing and fabrication requirements for these items can be readily understood.

At locations of *connections*, the following requirements shall apply to column stiffeners, web doubler plates, beam bearing stiffeners, and all other member reinforcement required to satisfy strength and equilibrium of forces through the *connection*:

- (1) When Option 1 or 2 in Section 3.1.1 is specified for a *connection*, these items shall be designed by the *owner's designated representative for design* and shown in the structural *design documents* issued for bidding so that the quantity, detailing and fabrication requirements for member reinforcement at *connections* can be readily understood.
- (2) When Option 3 in Section 3.1.1 is specified for a *connection*, two subsidiary options are available to the *owner's designated representative for design*; either:
  - (a) Option 3A: member reinforcement at *connections* shall be designed by the *owner's designated representative for design* and shown in the structural *design documents* issued for bidding so that the quantity, detailing and fabrication requirements for member reinforcement at *connections* can be readily understood, or;
  - (b) Option 3B: the *owner's designated representative for design* shall provide a bidding quantity of items required for member reinforcement at *connections* with corresponding project-specific details that show the conceptual configuration of reinforcement appropriate for the order of magnitude of forces to be transferred. These quantities and project-specific conceptual configurations will be relied upon for bidding purposes. If no quantities or conceptual configurations are shown, member reinforcement at *connections* will not be included in the bid.

Subsequently, member reinforcement at *connections*, where required, shall be designed in its final configuration by the licensed engineer in responsible charge of the *connection* design.

When the actual quantity and/or details of any of the foregoing items differ from the bidding quantity and/or details, the contract price and schedule shall be adjusted equitably in accordance with Sections 9.4 and 9.5.

Any limitations regarding type and connection of reinforcing shall be clearly provided.

**Commentary:**

Option 3A is most useful when the *owner's designated representative for design* delegates *connection* design work but has selected member sizes to eliminate or

minimize the need for member reinforcement at *connections*. Option 3A should not be used if the intent is to delegate the determination and design of member reinforcement at *connections* to the licensed engineer in responsible charge of the *connection* design.

Option 3B is necessary if the intent is to delegate the determination and design of member reinforcement at *connections* to the licensed engineer in responsible charge of the *connection* design. Because these requirements will not be known until *connections* are designed after award of the contract, bids prepared by multiple *fabricators* will not be comparable unless all bidders use the same assumptions in preparing their bids. The approach provided here allows for all bids to be comparable. The *owner's* final cost for the actual member reinforcement requirements at *connections* will be determined through equitable contract price adjustment.

When no quantities and details are shown for column stiffeners, web doubler plates, beam bearing stiffeners, and/or other member reinforcement required to satisfy strength and equilibrium of forces through *connections*, the *fabricator's* bid reflects no *allowance* for these items. Should it subsequently be determined that member reinforcement at *connections* is required, the provisions of Sections 9.4 and 9.5 then apply.

- 3.1.3. When leveling plates are to be furnished as part of the contract requirements, their locations and required thickness and sizes shall be specified in the *contract documents*.
- 3.1.4. When the *structural steel* frame, in the completely erected and fully connected state, requires interaction with non-*structural steel* elements (see Section 2) for strength and/or stability, those non-*structural steel* elements shall be identified in the *contract documents* as required in Section 7.10.

**Commentary:**

Examples of non-*structural steel* elements include diaphragms made of steel deck, diaphragms made of concrete on steel deck, and masonry and/or concrete shear walls.

- 3.1.5. When camber is required, the magnitude, direction and location of camber shall be specified in the structural *design documents*.

**Commentary:**

For cantilevers, the specified camber may be up or down, depending upon the framing and loading.

- 3.1.6. Specific members or portions thereof that are to be left unpainted shall be identified in the *contract documents*. When shop painting is required, the painting requirements shall be specified in the *contract documents*, including the following information:

- (a) The identification of specific members or portions thereof to be painted.
- (b) The surface preparation that is required for these members.
- (c) The paint specifications and manufacturer's product identification, including color requirements, if any, that are required for these members.
- (d) The minimum dry-film shop-coat thickness that is required for these members.

**Commentary:**

Some members or portions thereof may be required to be left unpainted, such as those that will be in contact and acting compositely with concrete, or those that will receive spray-applied fire protection materials.

### 3.2. Architectural, Electrical and Mechanical Design Documents and Specifications

All requirements for the quantities, sizes and locations of *structural steel* shall be shown or noted in the structural *design documents*. The structural *design documents* are permitted to reference the architectural, electrical and/or mechanical *design documents* as a supplement to the structural *design documents* for the purposes of defining detail configurations and construction information.

When the referenced information is not available at the time of structural design, bidding, detailing or fabrication, subsequent *revisions* shall be the responsibility of the *owner* and shall be made in accordance with Sections 3.5 and 9.3.

### 3.3. Discrepancies

When discrepancies exist between the *design documents* and *specifications*, the *design documents* shall govern. When discrepancies exist between scale dimensions in the *design documents* and the figures written in them, the figures shall govern. When discrepancies exist between the structural *design documents* and the architectural, electrical or mechanical *design documents*, or the *design documents* for other trades, the structural *design documents* shall govern. When discrepancies exist between the *design drawings* and the *design model*, the governing document shall be as identified per Section 1.4.

When a discrepancy is discovered in the *contract documents* in the course of the *fabricator's* work, the *fabricator* shall promptly notify the *owner's designated representative for construction* so that the discrepancy can be resolved. Such resolution shall be timely so as not to delay the *fabricator's* work. See Sections 3.5 and 9.3.

It is not the *fabricator's* responsibility to discover discrepancies, including those that are associated with the coordination of the various design disciplines.

### 3.4. Legibility of Design Drawings

*Design drawings* shall be clearly legible and drawn to an identified scale that is appropriate to clearly convey the information.

**Commentary:**

Historically, the most commonly accepted scale for *structural steel* drawings has been  $\frac{1}{8}$  in. per ft (10 mm per 1 000 mm). There are, however, situations where a

smaller or larger scale is appropriate. Ultimately, consideration must be given to the clarity of the drawing.

The scaling of the *design drawings* to determine dimensions is not an accepted practice for detailing the *approval documents*. However, it should be remembered when preparing *design drawings* that scaling may be the only method available when early-submission drawings are used to determine dimensions for estimating and bidding purposes.

### 3.5. Revisions to the Design Documents and Specifications

*Revisions* to the *design documents* and *specifications* shall be made either by issuing new *design documents* and *specifications* or by reissuing the existing *design documents* and *specifications*. In either case, all *revisions*, including revisions that are communicated through responses to *RFIs* or the annotation of the *approval documents* (see Section 4.4.2), shall be clearly and individually indicated in the *contract documents*. The *contract documents* shall be dated and identified by *revision* number. When the *design documents* are communicated using *design drawings*, each *design drawing* shall be identified by the same drawing number throughout the duration of the project, regardless of the *revision*. See also Section 9.3.

When *revisions* are communicated using *design models*, *revisions* shall be made evident in the revised *design model* submitted by identifying within the *design model* which items are changed. Alternatively, the changes shall be submitted with a written document describing in explicit detail the items that are changed. A historic tracking of changes must either be present in the revised *design model* or maintained in the written record of changes.

The party or entity that is contractually assigned responsibility for managing the *design model* shall maintain accurate accounting and tracking records of the most current *design model*, as well as previously superseded *design models*, and shall facilitate a tracking mechanism so that all contracted parties are aware of, and have access to, the most current *design model*.

#### **Commentary:**

*Revisions* to the *design documents* and *specifications* can be made by issuing sketches and supplemental information separate from the design documents and *specifications*. These sketches and supplemental information become amendments to the *design documents* and *specifications* and are considered new *contract documents*. All sketches and supplemental information must be uniquely identified with a number and date as the latest instructions until such time as they may be superseded by new information.

When *revisions* are made by revising and reissuing the existing structural *design documents* and/or *specifications*, a unique *revision* number and date must be added to those documents to identify that information as the latest instructions until such time as they may be superseded by new information. When the *design documents* are communicated using *design drawings*, the same unique drawing number must identify each *design drawing* throughout the duration of the project so that *revisions* can be properly tracked, thus avoiding confusion and miscommunication among the various entities involved in the project.

When *revisions* are communicated through the annotation of the *approval documents* or contractor submissions, such changes must be confirmed in writing by one of the aforementioned methods. This written confirmation is imperative to maintain control of the cost and schedule of a project and to avoid potential errors in fabrication.

When *design models* are used, a similar unique method of identifying each *revision* must be used. This method can vary in various digital modeling software, but the same level of notation of changes must be present in the revised *design model* as would be used on *design drawings*.

### 3.6. Fast-Track Project Delivery

When the fast-track project delivery system is selected, release of the structural *design documents* and *specifications* shall constitute a *release for construction*, regardless of the status of the architectural, electrical, mechanical and other interfacing designs and *contract documents*. Subsequent *revisions*, if any, shall be the responsibility of the owner and shall be made in accordance with Sections 3.5 and 9.3.

#### **Commentary:**

The fast-track project delivery system generally provides for a condensed schedule for the design and construction of a project. Under this delivery system, the *owner* elects to *release for construction* the structural *design documents* and *specifications*, which may be partially complete, at a time that may precede the completion of and coordination with architectural, mechanical, electrical and other design work and *contract documents*. The release of the structural *design documents* and *specifications* may also precede the release of the General Conditions and Division 1 Specifications.

Release of the structural *design documents* and *specifications* to the *fabricator* for ordering of material constitutes a *release for construction*. Accordingly, the *fabricator* and the *erector* may begin their work based upon those partially complete documents. As the architectural, mechanical, electrical and other design elements of the project are completed, *revisions* may be required in design and/or construction. Thus, when considering the fast-track project delivery system, the owner should balance the potential benefits to the project schedule with the project cost contingency that may be required to allow for these subsequent *revisions*.

### 3.7 Intellectual Property

Any copyright or other property or proprietary rights owned by the *owner's designated representative for design* in any content included within the *contract documents*, whether created specifically for an individual project or otherwise made available for use on an individual project, shall remain the exclusive property of the *owner's designated representative for design*.

## SECTION 4. APPROVAL DOCUMENTS

### 4.1. Owner Responsibility

The *owner* shall furnish, in a timely manner and in accordance with the *contract documents*, the complete structural *design documents* and *specifications* that have been *released for construction*. Unless otherwise noted, *design documents* and *specifications* that are provided as part of the contract bid documents shall constitute authorization by the *owner* that the *design documents* and *specifications* are *released for construction*.

#### **Commentary:**

When the *owner* issues *design documents* and *specifications* that are *released for construction*, the *fabricator* and the *erector* rely on the fact that these are the *owner's* requirements for the project. This release is required by the *fabricator* prior to the ordering of material and the preparation and completion of the *approval documents*.

To ensure the orderly flow of material procurement, detailing, fabrication and erection activities, on phased construction projects, it is essential that designs are not continuously revised after they have been *released for construction*. In essence, once a portion of a design is *released for construction*, the essential elements of that design should be “frozen” to ensure adherence to the contract price and construction schedule. Alternatively, all parties should reach a common understanding of the effects of future changes, if any, as they affect scheduled deliveries and added costs.

A pre-detailing conference, held after the *structural steel* fabrication contract is awarded, can benefit the project. Typical attendees may include the *owner's* *designated representative for construction*, the *owner's* *designated representative for design*, the *fabricator*, the *steel detailer*, and the *erector*. Topics of the meeting should relate to the specifics of the project and might include:

- Contract document review and general project overview, including *clarifications* of scope of work, tolerances, layouts and sequences, and special considerations.
- Detailing and coordination needs, such as bolting, welding, and *connection* considerations, constructability considerations, OSHA requirements, coordination with other trades, and the advanced bill of materials.
- The project communication system, including distribution of contact information for relevant parties to the contract, identification of the primary and alternate contacts in the general contractor's office, and the *RFI* system to be used on the project.
- The submittal schedule, including the method of submitting (electronic or hard copy); for hard copy, how many copies of documents are required; *connection* submittals; and identification of schedule-critical areas of the project, if any.
- If digital models will be used as part of the delivery method for the *design documents*, the parties should determine and convey the *levels of development (LOD)*, the digital model types that will be furnished, the authorized uses of

such digital models, the transmission of digital models to prevent the loss or alteration of data, interoperability, and methods of review and approval. The term *levels of development* refers to the level of completeness of elements within the digital model (see the BIMFORUM Level of Development Specification). The term “authorized uses” refers to the permitted uses of the digital model(s) and the digital data associated with the digital model(s). Such authorized uses may include the right to (1) store and view the digital model(s) for informational purposes only, (2) rely upon, store and view the digital model(s) to carry out the work on the project, (3) reproduce and distribute the digital model(s) for informational purposes only, (4) rely upon, reproduce and distribute the digital model(s) to carry out the work, (5) incorporate additional digital data into the digital model(s) without modifying the data received to carry out the work on the project, (6) modify the digital model(s) as required to carry out the work on the project, (7) produce the digital model(s) in an archival format for the *owner* to use as a reference for as-built construction data and/or for the operation of the project after completion, and/or (8) other authorized uses specified in the *contract documents*.

- Review of quality and inspection requirements, including the approvals process for corrective work.

Record of the meeting should be written and distributed to all parties. Subsequent meetings to discuss progress and issues that arise during construction also can be helpful, particularly when they are held on a regular schedule.

## 4.2. Fabricator Responsibility

4.2.1. Except as provided in Section 4.5, the *fabricator* shall produce the *approval documents* for the fabrication and erection of the structural steel and is responsible for the following:

- (a) The transfer of information from the *contract documents* into accurate and complete *approval documents*.
- (b) The development of accurate, detailed dimensional information to provide for the fit-up of parts in the field.

### Commentary:

The *fabricator* is permitted to use the services of independent *steel detailers* to produce *approval documents* and to perform other support services, such as producing advanced bills of material and bolt summaries.

As the *fabricator* develops the detailed dimensional information for production of the *approval documents*, there may be discrepancies, missing information or conflicts discovered in the *contract documents*. See Section 3.3.

4.2.2. Any copyright or other property or proprietary rights owned by the *fabricator* in any content included within the *approval documents*, whether created specifically for an individual project or otherwise made available for use on an individual project, shall remain the exclusive property of the *fabricator*.



- 4.2.3. When the *approval documents* are *shop and erection drawings*, each *shop and erection drawing* shall be identified by the same drawing number throughout the duration of the project and shall be identified by *revision* number and date, with each specific *revision* clearly identified. When the *approval documents* are *fabrication and erection models*, each submittal shall be uniquely identified.

When the *fabricator* submits a request to change *connection* details that are described in the *contract documents*, the *fabricator* shall notify the *owner's designated representatives for design and construction* in writing in advance of the submission of the *approval documents*. The *owner's designated representative for design* shall review and approve or reject the request in a timely manner.

When requested to do so by the *owner's designated representative for design*, the *fabricator* shall provide to the *owner's designated representatives for design and construction* its schedule for the submittal of *approval documents* so as to facilitate the timely flow of information between all parties.

**Commentary:**

When the *fabricator* intends to make a submission of alternative *connection* details to those shown in the *contract documents*, the *fabricator* must notify the *owner's designated representatives for design and construction* in advance. This will allow the parties involved to plan for the increased effort that may be required to review the alternative *connection* details. In addition, the *owner* will be able to evaluate the potential for cost savings and/or schedule improvements against the additional design cost for review of the alternative *connection* details by the *owner's designated representative for design*. This evaluation by the *owner* may result in the rejection of the alternative *connection* details or acceptance of the submission for review based upon cost savings, schedule improvements and/or job efficiencies.

The *owner's designated representative for design* may request the *fabricator's* schedule for the submittal of the *approval documents*. This process is intended to allow the parties to plan for the staffing demands of the submission schedule. The *contract documents* may address this issue in more detail. In the absence of the requirement to provide this schedule, none need be provided.

When the *fabricator* provides a schedule for the submission of the *approval documents*, it must be recognized that this schedule may be affected by *revisions* and the response time to requests for missing information or the resolution of discrepancies.

#### 4.3. Use of Digital Files or Copies of the Design Documents

The *fabricator* shall neither use nor reproduce any part of the *design documents* as part of the *approval documents* without the written permission of the *owner's designated representative for design*. When digital files or copies of the *design documents* are made available for the *fabricator's* use as part of the *approval documents*, the *fabricator* shall accept this information under the following conditions:

- (a) All information contained in the digital files or copies of the *design documents* shall be considered instruments of service of the *owner's designated representative for design* and shall not be used for other projects, additions to the project

- or the completion of the project by others. Digital files or copies of the *design documents* shall remain the property of the *owner's designated representative for design* and in no case shall the transfer of these copies of the *design documents* be considered a sale or unrestricted license.
- (b) CAD files or copies of the *design drawings* shall not be considered to be *contract documents*. In the event of a conflict between the *design drawings* and the CAD files or copies thereof, the *design drawings* shall govern.
  - (c) When a *design model* is made available for use by the *fabricator*, the *owner's designated representative for construction* shall designate whether the *design model* and/or other documents are to be considered the *contract documents*. See Section 1.4.
  - (d) Any party or entity that creates a copy of the *design model* does so at their own risk.
  - (e) The use of copies of the *design documents* shall not in any way obviate the *fabricator's* responsibility for proper checking and coordination of dimensions, details, member sizes and fit-up, and quantities of materials as required to facilitate the preparation of *approval documents* that are complete and accurate as required in Section 4.2.
  - (f) If copies of *design drawings* are used by the *fabricator*, the *fabricator* shall remove information that is not required for the fabrication or erection of the *structural steel* from the copies of the *design drawings*.

**Commentary:**

Copies of the *design documents* often are readily available to the *fabricator*. As a result, the *owner's designated representative for design* may have reduced control over the unauthorized use of the *design documents*. There are many copyright and other legal issues to be considered.

The *owner's designated representative for design* may choose to make copies of the *design documents* available to the *fabricator*, and may charge a service or licensing fee for this convenience. In doing so, a carefully negotiated agreement should be established to set out the specific responsibilities of both parties in view of the liabilities involved for both parties. For sample contracts, see Consensus Docs 301 BIM Addendum, AIA Document E202 Building Information Modeling Protocol Exhibit, AIA Document E203 Building Information Modeling and Digital Data Exhibit, AIA Document G201 Project Digital Data Protocol Form, and AIA Document G202 Project Building Information Modeling Protocol Form.

Once the *design model* has been accessed and/or modified by any entity other than the *owner's designated representative for design*, the resulting model is considered a copy of the *design model* and is no longer part of the *contract documents*.

The copies of the *design documents* are provided to the *fabricator* for convenience only. The information therein should be adapted for use only in reference to the placement of *structural steel* members during erection. The *fabricator* should treat this information as if it were fully produced by the *fabricator* and undertake the same level of checking and quality assurance. When amendments or *revisions* are made to the *contract documents*, the *fabricator* must update this reference material.

When copies of the *design drawings* are provided to the *fabricator*, they often contain other information, such as architectural backgrounds or references to other *contract documents*. This additional material should be removed when producing the *approval documents* to avoid the potential for confusion.

Just like the transmission of the *design documents* created by the *owner's designated representative for design* does not convey ownership rights in the *design documents*, the transmission of the approval documents created by the *fabricator* does not convey ownership rights in the *approval documents*.

#### 4.4. Approval

Except as provided in Section 4.5, the *approval documents* shall be submitted to the *owner's designated representatives for design* and construction for review and approval. The *approval documents* shall be returned to the *fabricator* within 14 calendar days.

Final *substantiating connection information*, if any, shall also be submitted with the *approval documents*. The *owner's designated representative for design* is the final authority in the event of a disagreement between parties regarding the design of *connections* to be incorporated into the overall *structural steel* frame. The *fabricator* and licensed engineer in responsible charge of *connection* design are entitled to rely upon the *connection* design criteria provided in accordance with Section 3.1.1. *Revisions* to these criteria shall be addressed in accordance with Sections 9.3 and 9.4.

Approved *approval documents* shall be individually annotated by the *owner's designated representatives for design* and *construction* as either approved or approved subject to corrections noted. When so required, the *fabricator* shall subsequently make the corrections noted and furnish corrected *fabrication* and *erection documents* to the *owner's designated representatives for design* and *construction*.

##### **Commentary:**

As used in this Code, the 14-day allotment for the return of *approval documents* is intended to represent the *fabricator's* portal-to-portal time. The intent in this Code is that, in the absence of information to the contrary in the *contract documents*, 14 days may be assumed for the purposes of bidding, contracting and scheduling. When additional time is desired, such as when *substantiating connection information* is part of the submittals, the modified allotment should be specified in the *contract documents*. A submittal schedule is commonly used to facilitate the approval process.

If the *approval documents* are approved subject to corrections noted, the *owner's designated representative for design* may or may not require that it be resubmitted for record purposes following correction. If the *approval documents* are not approved, *revisions* must be made and the documents resubmitted until approval is achieved.

- 4.4.1. Approval, approval subject to corrections noted, and similar approvals of the *approval documents* shall constitute the following:

- (a) Confirmation that the *fabricator* has correctly interpreted the *contract documents* in the preparation of those submittals.
- (b) Confirmation that the *owner's designated representative* for design has reviewed and approved the *connection* details shown in the *approval documents* and submitted in accordance with Section 3.1.1, if applicable.
- (c) Release by the *owner's designated representatives for design and construction* for the *fabricator* to begin fabrication using the approved submittals.

Such approval shall not relieve the *fabricator* of the responsibility for either the accuracy of the detailed dimensions in the *approval documents* or the general fit-up of parts that are to be assembled in the field.

The *fabricator* shall determine the fabrication schedule that is necessary to meet the requirements of the contract.

**Commentary:**

When considering the current language in this Section, the Committee sought language that would parallel the practices of CASE. In CASE Document 962, CASE indicates that when the design of some element of the primary structural system is left to someone other than the *structural engineer of record*, "...such elements, including *connections* designed by others, should be reviewed by the *structural engineer of record*. He [or she] should review such designs and details, accept or reject them and be responsible for their effects on the primary structural system." Historically, this Code has embraced this same concept.

From the inception of this Code, AISC and the industry in general have recognized that only the *owner's designated representative for design* has all the information necessary to evaluate the total impact of *connection* details on the overall structural design of the project. This authority traditionally has been exercised during the approval process for the *approval documents*. The *owner's designated representative for design* has thus retained responsibility for the adequacy and safety of the entire structure since at least the 1927 edition of this Code.

- 4.4.2. Unless otherwise noted, any additions, deletions or *revisions* that are indicated in responses to *RFIs* or on the approved *approval documents* shall constitute authorization by the *owner* that the additions, deletions or *revisions* are *released for construction*. The *fabricator* and the *erector* shall promptly notify the *owner's designated representative for construction* when any direction or notation in responses to *RFIs* or on the *approval documents* or other information will result in an additional cost and/or a delay. See Sections 3.5 and 9.3.

**Commentary:**

When the *fabricator* notifies the *owner's designated representative for construction* that a direction or notation in responses to *RFIs* or on the *approval documents* will result in an additional cost or a delay, it is then normally the responsibility of the *owner's designated representative for construction* to subsequently notify the *owner's designated representative for design*.

#### 4.5. Fabrication and/or Erection Documents Not Furnished by the Fabricator

When the *fabrication* and *erection documents* are not prepared by the *fabricator*, but are furnished by others, they shall be delivered to the *fabricator* in a timely manner, or as agreed upon in the *contract documents*. These *fabrication* and *erection documents* shall be prepared, insofar as is practical, in accordance with the shop fabrication and detailing standards of the *fabricator*. The *fabricator* shall not be responsible for the completeness, coordination, or accuracy of *fabrication* and *erection documents* so furnished, nor for the general fit-up of the members that are fabricated from them.

##### **Commentary:**

This delivery system of *fabrication* and *erection documents* is discouraged. The preparation of the *fabrication* and *erection documents* is very specific to the needs of the *fabricator* performing the work, and an integral part of the constructability and coordination assurance of the project. If the project team chooses to use this delivery method, the *contract documents* should be very clear as to the managing of this process, including, but not limited to, who and how the following will be handled:

- Standards, format and contents of the *fabrication* and *erection documents*, or representative documents that will be part of the *contract documents*, for the mill order and for fabrication, including field bolts.
- Provisions for proper risk management (errors and omissions or product liability, as applicable).
- Normal “pre-detailing” sequencing, OSHA erection aids, and other Sub Part R requirements incorporated.
- Schedule updates for documents, and impact to overall project schedule and contract, as these dates are impacted.
- *Revision of fabrication* and *erection documents* and control of in order to maintain the integrity of all parts of the *fabrication* and *erection documents*.
- Late released items.
- Shop question support, including those that arise on night shifts and weekends.
- Joist, deck and other commodity item question and coordination support.
- Field question support.

#### 4.6. The RFI Process

When *requests for information (RFIs)* are issued, the process shall include the maintenance of a written record of inquiries and responses related to interpretation and implementation of the *contract documents*, including the *clarifications* and/or *revisions* to the *contract documents* that result, if any. *RFIs* shall not be used for the incremental *release for construction* of the *design documents*. When *RFIs* involve discrepancies or *revisions*, see Sections 3.3, 3.5 and 4.4.2.

When a *design model* is used as the *design documents*, the changes and/or *clarifications* made in response to *RFIs* shall be incorporated into the *design model*.

**Commentary:**

The *RFI* process is most commonly used during the detailing process, but can also be used to forward inquiries by the *erector* or to inform the *owner's designated representative for design* in the event of a *fabricator* or *erector* error and to develop corrective measures to resolve such errors.

The *RFI* process is intended to provide a written record of inquiries and associated responses but not to replace all verbal communication between the parties on the project. *RFIs* should be prepared and responded to in a timely fashion so as not to delay the work of the *steel detailer*, *fabricator* and *erector*. Discussion of the *RFI* issues and possible solutions between the *fabricator*, *erector* and *owner's designated representatives for design* and *construction* often can facilitate timely and practical resolution. Unlike submittals in Section 4.4, *RFI* response time can vary depending on the urgency of the issue, the amount of work required by the *owner's designated representatives for design* and *construction* to develop a complete response, and other circumstances, such as building official approval.

*RFIs* should be prepared in a standardized format, including *RFI* number and date, identity of the author, reference to a specific location(s) in the *design documents* or *specification* section, the needed response date, a description of a suggested solution (graphic depictions are recommended for more complex issues), and an indication of possible schedule and cost impacts. *RFIs* should be limited to one question each (unless multiple questions are interrelated to the same issue) to facilitate the resolution and minimize response time. Questions and proposed solutions presented in *RFIs* should be clear and complete. *RFI* responses should be equally clear and complete in the depictions of the solutions, and signed and dated by the responding party.

Unless otherwise noted, the *fabricator* and *erector* can assume that a response to an *RFI* constitutes a *release for construction*. However, if the response will result in an increase in cost or a delay in schedule, Section 4.4.2 requires that the *fabricator* and/or *erector* promptly inform the *owner's designated representatives for design* and *construction*.

#### 4.7 Erection Documents

The *erection documents* shall be provided to the *erector* in a timely manner so as to allow the *erector* to properly plan and perform the work.

**Commentary:**

For planning purposes, this may include release of preliminary *erection documents*, if requested by the *erector*.

## SECTION 5. MATERIALS

### 5.1. Mill Materials

Unless otherwise noted in the *contract documents*, the *fabricator* is permitted to order the materials that are necessary for fabrication when the *fabricator* receives *contract documents* that have been *released for construction*.

#### **Commentary:**

The *fabricator* may purchase materials in stock lengths, exact lengths or multiples of exact lengths to suit the dimensions shown in the structural *design documents*. Such purchases will normally be job-specific in nature and may not be suitable for use on other projects or returned for full credit if subsequent design changes make these materials unsuitable for their originally intended use. The *fabricator* should be paid for these materials upon delivery from the mill, subject to appropriate additional payment or credit if subsequent unanticipated modification or reorder is required. Purchasing materials to exact lengths is not considered fabrication.

- 5.1.1. Unless otherwise specified by means of special testing requirements in the *contract documents*, mill testing shall be limited to those tests that are required for the material in the ASTM specifications indicated in the *contract documents*. Materials ordered to special material requirements shall be marked by the supplier as specified in ASTM A6/A6M Section 12 prior to delivery to the *fabricator's* shop or other point of use. Such material not so marked by the supplier, shall not be used until:
- (a) Its identification is established by means of testing in accordance with the applicable ASTM specifications.
  - (b) A *fabricator's* identification mark, as described in Section 6.1.2 and 6.1.3, has been applied.
- 5.1.2. When *mill material* does not satisfy ASTM A6/A6M tolerances for camber, profile, flatness or sweep, the *fabricator* shall be permitted to perform corrective procedures, including the use of controlled heating and/or mechanical straightening, subject to the limitations in ANSI/AISC 360.

#### **Commentary:**

Mill dimensional tolerances are completely set forth in ASTM A6/A6M. Normal variations in the cross-sectional geometry of *standard structural shapes* must be recognized by the designer, the *fabricator*, the *steel detailer*, and the *erector* (for example, see Figure C-5.1). Such tolerances are mandatory because roll wear, thermal distortions of the hot cross section immediately after leaving the forming rolls and differential cooling distortions that take place on the cooling beds are all unavoidable. Geometric perfection of the cross section is not necessary for either structural or architectural reasons, if the tolerances are recognized and provided for.

ASTM A6/A6M also stipulates tolerances for straightness that are adequate for typical construction. However, these characteristics may be controlled or corrected to closer tolerances during the fabrication process when the added cost is justified by the special requirements for an atypical project.

- 5.1.3. When variations that exceed ASTM A6/A6M tolerances are discovered or occur after the receipt of *mill material* the *fabricator* shall, at the *fabricator's* option, be permitted to perform the ASTM A6/A6M corrective procedures for mill reconditioning of the surface of *structural steel* shapes and plates.
- 5.1.4. When special tolerances that are more restrictive than those in ASTM A6/A6M are required for *mill materials*, such special tolerances shall be specified in the *contract documents*. The *fabricator* shall, at the *fabricator's* option, be permitted to order material to ASTM A6/A6M tolerances and subsequently perform the corrective procedures described in Sections 5.1.2 and 5.1.3.

## 5.2. Stock Materials

- 5.2.1. If used for structural purposes, materials that are taken from stock by the *fabricator* shall be of a quality that is at least equal to that required in the ASTM specifications indicated in the *contract documents*.
- 5.2.2. Material test reports shall be accepted as sufficient record of the quality of materials taken from stock by the *fabricator*. The *fabricator* shall review and retain the material test reports that cover such stock materials. However, the *fabricator* need not maintain records that identify individual pieces of stock material against individual material test reports, provided the *fabricator* purchases stock materials that meet the requirements for material grade and quality in the applicable ASTM specifications.
- 5.2.3. Stock materials that are purchased under no particular specification, under a specification that is less rigorous than the applicable ASTM specifications or without material test reports or other recognized test reports shall not be used without the approval of the *owner's designated representative for design*.



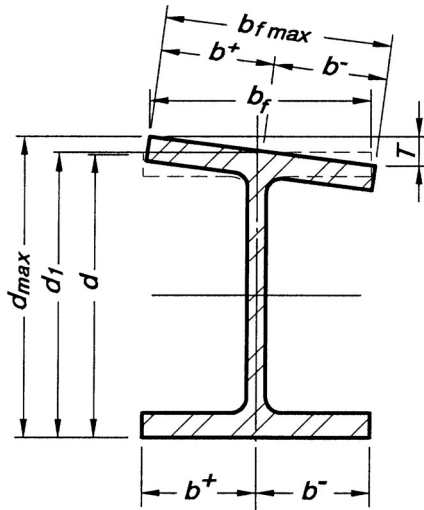

**U.S. customary units:**

**Flange-tilt tolerances:**

$$T + T' = 1/4 \text{ in. for } d \leq 12 \text{ in.}$$

$$= 5/16 \text{ in. for } d > 12 \text{ in.}$$

**Actual depth with tolerances:**

$$d_1 = d \text{ plus or minus } 1/8 \text{ in. (typ.)}$$

$$d_{max} = d + T + T'$$

**Actual flange width with tolerances:**

$$b^+ = 1/2 b_f \text{ plus or minus } 3/16 \text{ in.}$$

$$b^- = 1/2 b_f \text{ minus or plus } 3/16 \text{ in.}$$

$$b_{max} = b_f \text{ plus } 1/4 \text{ in. or minus } 3/16 \text{ in.}$$

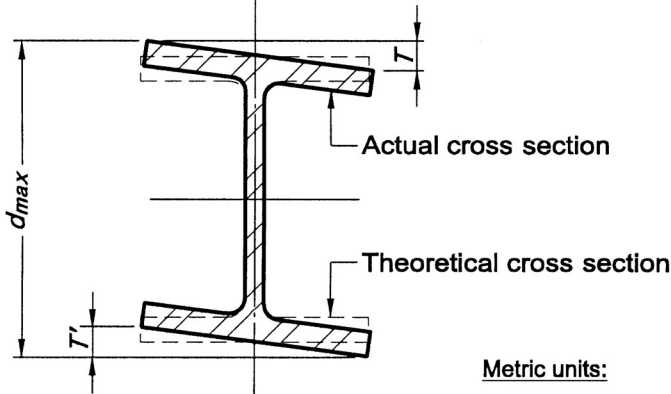

**Metric units:**

**Flange-tilt tolerances:**

$$T + T' = 6 \text{ mm for } d \leq 300 \text{ mm}$$

$$= 8 \text{ mm for } d > 300 \text{ mm}$$

**Actual depth with tolerances:**

$$d_1 = d \text{ plus or minus } 3 \text{ mm}$$

$$d_{max} = d + T + T'$$

**Actual flange width with tolerances:**

$$b^+ = 1/2 b_f \text{ plus or minus } 5 \text{ mm}$$

$$b^- = 1/2 b_f \text{ minus or plus } 5 \text{ mm}$$

$$b_{max} = b_f \text{ plus } 6 \text{ mm or minus } 5 \text{ mm}$$

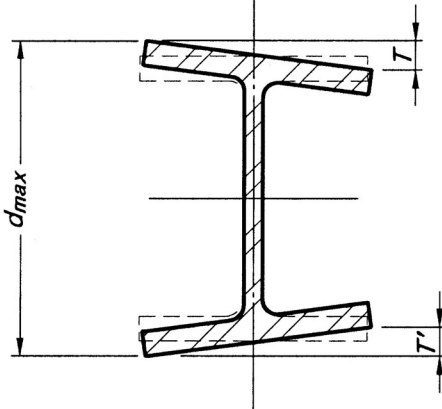

Fig. C-5.1. Mill tolerances on the cross section of a W-shape.

## SECTION 6. SHOP FABRICATION AND DELIVERY

### 6.1. Identification of Material

6.1.1. The *fabricator* shall be able to demonstrate by written procedure and actual practice a method of material identification, visible up to the point of assembling members as follows:

- (a) For shop-standard material, identification capability shall include shape designation. Representative material test reports shall be furnished by the *fabricator* if requested to do so by the *owner's designated representative for design*, either in the *contract documents* or in separate written instructions given to the *fabricator* prior to ordering *mill materials*.
- (b) For material of grade other than shop-standard material, identification capability shall include shape designation and material grade. Representative material test reports shall be furnished by the *fabricator* if requested to do so by the *owner's designated representative for design*, either in the *contract documents* or in separate written instructions given to the *fabricator* prior to ordering *mill materials*.
- (c) For material ordered in accordance with an ASTM supplement or other special material requirements in the *contract documents*, identification capability shall include shape designation, material grade and heat number. The corresponding material test reports shall be furnished by the *fabricator* if requested to do so by the *owner's designated representative for design*, either in the *contract documents* or in separate written instructions given to the *fabricator* prior to ordering *mill materials*.

Unless an alternative system is established in the *fabricator's* written procedures, shop-standard material shall be as follows:

<b>Material</b>	<b>Shop-Standard Material Grade</b>
W and WT	ASTM A992/A992M
M, S, MT and ST	ASTM A36/A36M
HP	ASTM A572/A572M Grade 50
L	ASTM A36/A36M
C and MC	ASTM A36/A36M
HSS	ASTM A500/A500M Grade C
Steel Pipe	ASTM A53/A53M Grade B
Plates and Bars	ASTM A36/A36M

#### **Commentary:**

The requirements in Section 6.1.1(a) will suffice for most projects. When material is of a strength level that differs from the shop-standard grade, the requirements in Section 6.1.1(b) apply. When special material requirements apply, such as ASTM A6/A6M supplement S5 or S30 for CVN testing or ASTM A6/A6M supplement S8 for ultrasonic testing, the requirements in Section 6.1.1(c) are applicable.

- 6.1.2. During fabrication, up to the point of assembling members, each piece of material that is ordered to special material requirements shall carry a *fabricator's* identification mark or an original supplier's identification mark. The *fabricator's* identification mark shall be in accordance with the *fabricator's* established material identification system, which shall be on record and available prior to the start of fabrication for the information of the *owner's designated representative for construction*, the building code authority and the *inspector*.
- 6.1.3. Members that are made of material that is ordered to special material requirements shall not be given the same assembling or erection mark as members made of other material, even if they are of identical dimensions and detail.

## 6.2. Preparation of Material

- 6.2.1. The thermal cutting of *structural steel* by hand-guided or mechanically guided means is permitted.
- 6.2.2. Surfaces that are specified as "finished" in the *contract documents* shall have a roughness height value measured in accordance with ASME B46.1 that is equal to or less than 500  $\mu\text{in.}$  (12.7  $\mu\text{m}$ ). The use of any fabricating technique that produces such a finish is permitted.

### Commentary:

Most cutting processes, including friction sawing and cold sawing, and milling processes meet a surface roughness limitation of 500  $\mu\text{in.}$  (12.7  $\mu\text{m}$ ) per ASME B46.1.

## 6.3. Fitting and Fastening

- 6.3.1. Projecting elements of *connection* materials need not be straightened in the connecting plane, subject to the limitations in ANSI/AISC 360.
- 6.3.2. Backing and runoff tabs shall be used in accordance with AWS D1.1/D1.1M as required to produce sound welds. The *fabricator* or *erector* need not remove backing or runoff tabs unless such removal is specified in the *contract documents*. When the removal of backing is specified in the *contract documents*, such removal shall meet the requirements in AWS D1.1/D1.1M. When the removal of runoff tabs is specified in the *contract documents*, hand flame-cutting close to the edge of the finished member with no further finishing is permitted, unless other finishing is specified in the *contract documents*.

### Commentary:

In most cases, the treatment of backing and runoff tabs is left to the discretion of the *owner's designated representative for design*. In some cases, treatment beyond the basic cases described in this Section may be required. As one example, special treatment is required for backing and runoff tabs in beam-to-column moment connections when the requirements in ANSI/AISC 341 must be met. In all cases, the *owner's designated representative for design* should specify the required treatments in the *contract documents*.

- 6.3.3. Unless otherwise noted in the *fabrication documents*, high-strength bolts for shop-attached *connection* material shall be installed in the shop in accordance with the requirements in ANSI/AISC 360.

#### 6.4. Fabrication Tolerances

The tolerances on *structural steel* fabrication shall be in accordance with the requirements in Section 6.4.1 through 6.4.6.

##### Commentary:

Fabrication tolerances are stipulated in several specifications and codes, each applicable to a specialized area of construction. Basic fabrication tolerances are stipulated in this Section. For *architecturally exposed structural steel*, see Section 10. Other specifications and codes are also commonly incorporated by reference in the *contract documents*, such as ANSI/AISC 360, the RCSC Specification, AWS D1.1/D1.1M, and the AASHTO Specification.

- 6.4.1. For members that have both ends finished (see Section 6.2.2) for contact bearing, the variation in the overall length shall be equal to or less than  $\frac{1}{32}$  in. (1 mm). For other members that frame to other *structural steel* elements, the variation in the detailed length shall be as follows:
- For members that are equal to or less than 30 ft (9 000 mm) in length, the variation shall be equal to or less than  $\frac{1}{16}$  in. (2 mm).
  - For members that are greater than 30 ft (9 000 mm) in length, the variation shall be equal to or less than  $\frac{1}{8}$  in. (3 mm).
- 6.4.2. For straight and curved structural members, whether of a single *standard structural shape* or built-up, the permitted variation in specified straightness or curvature shall be as listed below. In all cases, completed members shall be free of twists (except as allowed by ASTM standards), bends and open joints. Sharp kinks or sharp bends shall be cause for rejection.
- (a) For straight structural members other than compression members, the variation in straightness shall be equal to or less than that specified for structural shapes in the applicable ASTM standards except when a smaller variation is specified in the *contract documents*.
    - For straight compression members, the variation in straightness shall be equal to or less than  $\frac{1}{1000}$  of the axial length between points that are to be laterally supported.
  - (b) For curved structural members, the variation in the chord length shall be as defined in Section 6.4.1. The variation in curvature measured at the middle ordinate shall be equal to or less than the permissible variations in straightness as specified in applicable ASTM standards for camber in the strong direction and sweep in the weak direction, inside or outside of the theoretical arc, except when a smaller variation is specified in the *contract documents*. Should no applicable ASTM standard exist, the maximum variation in curvature measured at the

middle ordinate shall be plus or minus  $\frac{1}{8}$  in. (3 mm) times one-fifth the total arc length in ft (times two-thirds the total arc length in m) for members 10 ft (3 m) or greater in length. For members less than 10 ft (3 m) in length, the permissible variation in curvature measured at the middle ordinate shall be plus or minus  $\frac{1}{8}$  in. (3 mm). The middle ordinate is located between work points as shown in Figure C-6.1.

**Commentary:**

Curved structural members, as referred to in this section, are defined as those members intended to maintain a specified curvature while in use. This section does not apply to members specified for camber. The location of the arc length is defined by the contract drawings and may be either at the member's inside radius, the outside radius, or the radius between work points.

- 6.4.3. For beams that are detailed without specified camber, the member shall be fabricated so that, after erection, any incidental camber due to rolling or shop fabrication is upward. For trusses that are detailed without specified camber, the components shall be fabricated so that, after erection, any incidental camber in the truss due to rolling or shop fabrication is upward.
- 6.4.4. For beams that are specified in the *contract documents* with camber, beams received by the *fabricator* with 75% of the specified camber shall require no further cambering. Otherwise, the variation in camber shall be as follows:
- (a) For beams that are equal to or less than 50 ft (15 000 mm) in length, the variation shall be equal to or less than minus zero / plus  $\frac{1}{2}$  in. (13 mm).

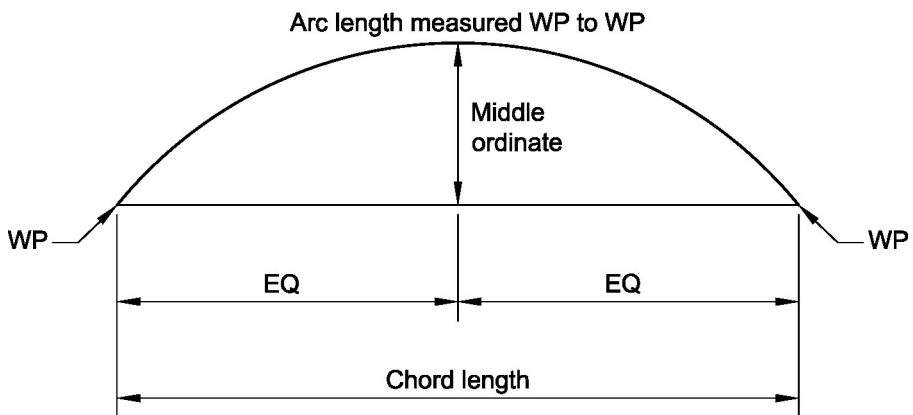

Fig. C-6.1. Illustration of the tolerance on curved structural steel member.

- (b) For beams that are greater than 50 ft (15 000 mm) in length, the variation shall be equal to or less than minus zero / plus  $\frac{1}{2}$  in. plus  $\frac{1}{8}$  in. for each 10 ft or fraction thereof (13 mm plus 3 mm for each 3 000 mm or fraction thereof) in excess of 50 ft (15 000 mm) in length.

For the purpose of inspection, camber shall be measured in the *fabricator's* shop in the unstressed condition.

**Commentary:**

There is no known way to inspect beam camber after the beam is received in the field because of factors that include:

- (a) The release of stresses in members over time and in varying applications.
- (b) The effects of the dead weight of the member.
- (c) The restraint caused by the end *connections* in the erected state.
- (d) The effects of additional dead load that may ultimately be intended to be applied, if any.

Therefore, inspection of the *fabricator's* work on beam camber must be done in the fabrication shop in the unstressed condition.

- 6.4.5. For fabricated trusses that are specified in the *contract documents* with camber, the variation in camber at each specified camber point shall be equal to or less than plus or minus  $\frac{1}{800}$  of the distance to that point from the nearest point of support. For the purpose of inspection, camber shall be measured in the *fabricator's* shop in the unstressed condition. For fabricated trusses that are specified in the *contract documents* without indication of camber, the foregoing requirements shall be applied at each panel point of the truss with a zero camber ordinate.

**Commentary:**

There is no known way to inspect truss camber after the truss is received in the field because of factors that include:

- (a) The effects of the dead weight of the member.
- (b) The restraint caused by the truss *connections* in the erected state.
- (c) The effects of additional dead load that may ultimately be intended to be applied, if any.

Therefore, inspection of the *fabricator's* work on truss camber must be done in the fabrication shop in the unstressed condition. See Figure C-6.2.

- 6.4.6. When permissible variations in the depths of beams and girders result in abrupt changes in depth at splices, such deviations shall be accounted for as follows:
- (a) For splices with bolted joints, the variations in depth shall be taken up with filler plates.
  - (b) For splices with welded joints, the weld profile shall be adjusted to conform to the variations in depth, the required cross section of weld shall be provided and the slope of the weld surface shall meet the requirements in AWS D1.1/D1.1M.

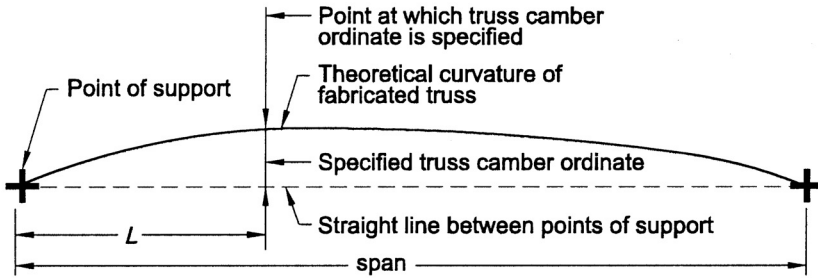

Taking  $L$  as the distance from the point at which truss camber is specified to the closer point of support, in. [mm], the tolerance on truss camber at that point is calculated as  $L/800$ .  $L$  must be equal to or less than one-half the span.

Fig. C-6.2. Illustration of the tolerance on camber for fabricated trusses with specified camber.

## 6.5. Shop Cleaning and Painting (see also Section 3.1.6)

*Structural steel* that does not require shop paint shall be cleaned of oil and grease with solvent cleaners, and of dirt and other foreign material by sweeping with a fiber brush or other suitable means. For *structural steel* that is required to be shop painted, the requirements in Sections 6.5.1 through 6.5.4 shall apply.

### Commentary:

Extended exposure of unpainted *structural steel* that has been cleaned for the subsequent application of fire protection materials can be detrimental to the fabricated product. Most levels of cleaning require the removal of all loose mill scale, but permit some amount of tightly adhering mill scale. When a piece of *structural steel* that has been cleaned to an acceptable level is left exposed to a normal environment, moisture can penetrate behind the scale, and some “lifting” of the scale by the oxidation process is to be expected. Cleanup of “lifted” mill scale is not the responsibility of the *fabricator*, but is to be assigned by contract requirement to an appropriate contractor.

Section 6.5.4 of this Code is not applicable to weathering steel, for which special cleaning specifications are always required in the *contract documents*.

- 6.5.1. The *fabricator* is not responsible for deterioration of the shop coat that may result from exposure to ordinary atmospheric conditions or corrosive conditions that are more severe than ordinary atmospheric conditions.

### Commentary:

The shop coat of paint is the prime coat of the protective system. It is intended as protection for only a short period of exposure in ordinary atmospheric conditions, and is considered a temporary and provisional coating.

- 6.5.2. Unless otherwise specified in the *contract documents*, the *fabricator* shall, as a minimum, hand clean the *structural steel* of loose rust, loose mill scale, dirt and other foreign matter, prior to painting, by means of wire brushing or by other methods elected by the *fabricator*, to meet the requirements of SSPC-SP2. If the *fabricator's* workmanship on surface preparation is to be inspected by the inspector, such inspection shall be performed in a timely manner prior to the application of the shop coat.

**Commentary:**

The selection of a paint system is a design decision involving many factors including:

- (a) The *owner's* preference.
- (b) The service life of the structure.
- (c) The severity of environmental exposure.
- (d) The cost of both initial application and future renewals.
- (e) The compatibility of the various components that comprise the paint system (surface preparation, shop coat and subsequent coats).

Because the inspection of shop painting must be concerned with workmanship at each stage of the operation, the *fabricator* provides notice of the schedule of operations and affords the *inspector* access to the work site. Inspection must then be coordinated with that schedule so as to avoid delay of the scheduled operations.

Acceptance of the prepared surface must be made prior to the application of the shop coat because the degree of surface preparation cannot be readily verified after painting. Time delay between surface preparation and the application of the shop coat can result in unacceptable deterioration of a properly prepared surface, necessitating a repetition of surface preparation. This is especially true with blast-cleaned surfaces. Therefore, to avoid potential deterioration of the surface, it is assumed that surface preparation is accepted unless it is inspected and rejected prior to the scheduled application of the shop coat.

The shop coat in any paint system is designed to maximize the wetting and adherence characteristics of the paint, usually at the expense of its weathering capabilities. Deterioration of the shop coat normally begins immediately after exposure to the elements and worsens as the duration of exposure is extended. Consequently, extended exposure of the shop coat will likely lead to its deterioration and may necessitate repair, possibly including the repetition of surface preparation and shop coat application in limited areas. With the introduction of high-performance paint systems, avoiding delay in the application of the shop coat has become more critical. High-performance paint systems generally require a greater degree of surface preparation, as well as early application of weathering protection for the shop coat.

Since the *fabricator* does not control the selection of the paint system, the compatibility of the various components of the total paint system, or the length of exposure of the shop coat, the *fabricator* cannot guarantee the performance of the shop coat or any other part of the system. Instead, the fabricator is responsible only for accomplishing the specified surface preparation and for applying the shop coat (or coats) in accordance with the *contract documents*.



This Section stipulates that the *structural steel* is to be cleaned to meet the requirements in SSPC-SP2. This stipulation is not intended to represent an exclusive cleaning level, but rather the level of surface preparation that will be furnished unless otherwise specified in the *contract documents* if the *structural steel* is to be painted.

- 6.5.3. Unless otherwise specified in the *contract documents*, paint shall be applied by brushing, spraying, rolling, flow coating, dipping or other suitable means, at the election of the *fabricator*. When the term “shop coat,” “shop paint,” or other equivalent term is used with no paint system specified, the *fabricator’s* standard shop paint shall be applied to a minimum dry-film thickness of one mil (25  $\mu\text{m}$ ).
- 6.5.4. Touch-up of abrasions caused by handling after painting shall be the responsibility of the contractor that performs touch-up in the field or field painting.

**Commentary:**

Touch-up in the field and field painting are not normally part of the *fabricator’s* or the *erector’s* contract.

## 6.6. Marking and Shipping of Materials

- 6.6.1. Unless otherwise specified in the *contract documents*, erection marks shall be applied to the *structural steel* members by painting or other suitable means.

Bolt assemblies and loose bolts, nuts and washers shall be shipped in separate closed containers according to length and diameter, as applicable. Pins and other small parts and packages of bolts, nuts and washers shall be shipped in boxes, crates, kegs or barrels. A list and description of the material shall appear on the outside of each closed container.

**Commentary:**

In most cases, bolts, nuts and other components in a fastener assembly can be shipped loose in separate containers. However, there are exceptions:

- ASTM F3125/F3125M Grades F1852 and F2280 twist-off-type tension-control bolt assemblies must be assembled and shipped in containers according to grade, length and diameter.
- Galvanized ASTM F3125/F3125M Grade A325 bolts and their corresponding ASTM A563 or A563M nuts must be shipped in the same container according to length and diameter.

See these ASTM standards for the applicable requirements and the RCSC Specification for further explanation.

## 6.7. Delivery of Materials

- 6.7.1. Fabricated *structural steel* shall be delivered in a sequence that will permit efficient and economical fabrication and erection, and that is consistent with requirements in the *contract documents*. If the owner or *owner's designated representative for construction* wishes to prescribe or control the sequence of delivery of materials, that entity shall specify the required sequence in the *contract documents*. If the *owner's designated representative for construction* contracts separately for delivery and for erection, the *owner's designated representative for construction* shall coordinate planning between contractors.
- 6.7.2. *Anchor rods*, washers, nuts and other anchorage or grillage materials that are to be built into concrete or masonry shall be shipped so that they will be available when needed. The *owner's designated representative for construction* shall allow the *fabricator* sufficient time to fabricate and ship such materials before they are needed.
- 6.7.3. If any shortage is claimed relative to the quantities of materials that are shown in the shipping statements, the *owner's designated representative for construction* or the *erector* shall promptly notify the *fabricator* so that the claim can be investigated.

### Commentary:

The quantities of material that are shown in the shipping statement are customarily accepted as correct by the *owner's designated representative for construction*, the *fabricator* and the *erector*.

- 6.7.4. Unless otherwise specified in the *contract documents*, and subject to the approved *approval documents*, the *fabricator* shall limit the number of field splices to that consistent with minimum project cost.

### Commentary:

This Section recognizes that the size and weight of *structural steel* assemblies may be limited by shop capabilities, the permissible weight and clearance dimensions of available transportation or job-site conditions.

- 6.7.5. If material arrives at its destination in damaged condition, the receiving entity shall promptly notify the *fabricator* and carrier prior to unloading the material, or promptly upon discovery prior to erection.

## SECTION 7. ERECTION

### 7.1. Method of Erection

Fabricated *structural steel* shall be erected using methods and a sequence that will permit efficient and economical performance of erection, and that is consistent with the requirements in the *contract documents*. If the *owner* or *owner's designated representative for construction* wishes to prescribe or control the method and/or sequence of erection, or specifies that certain members cannot be erected in their normal sequence, that entity shall specify the required method and sequence in the *contract documents*. If the *owner's designated representative for construction* contracts separately for fabrication services and for erection services, the *owner's designated representative for construction* shall coordinate planning between contractors.

#### **Commentary:**

Design modifications are sometimes requested by the erector to allow or facilitate the erection of the *structural steel* frame. When this is the case, the *erector* should notify the *fabricator* prior to the preparation of the *approval documents* so that the *fabricator* may refer the *erector's* request to the *owner's designated representatives for design and construction* for resolution.

### 7.2. Job-Site Conditions

The *owner's designated representative for construction* shall provide and maintain the following for the *fabricator* and the *erector*:

- (a) Adequate access roads into and through the job site for the safe delivery and movement of the material to be erected and of derricks, cranes, trucks and other necessary equipment under their own power.
- (b) A firm, properly graded, drained, convenient and adequate space at the job site for the operation of the *erector's* equipment, free from overhead obstructions, such as power lines, telephone lines or similar conditions.
- (c) Adequate storage space, when the structure does not occupy the full available job site, to enable the *fabricator* and the *erector* to operate at maximum practical speed.

Otherwise, the *owner's designated representative for construction* shall inform the *fabricator* and the *erector* of the actual job-site conditions and/or special delivery requirements prior to bidding.

### 7.3. Foundations, Piers and Abutments

The accurate location, strength and suitability of, and access to, all foundations, piers and abutments shall be the responsibility of the *owner's designated representative for construction*.

#### 7.4. Lines and Benchmarks

The *owner's designated representative for construction* shall be responsible for the accurate location of lines and benchmarks at the job site and shall furnish the *erector* with a plan that contains all such information. The *owner's designated representative for construction* shall establish offset lines and reference elevations at each level for the *erector's* use in the positioning of *adjustable items* (see Section 7.13.1.3), if any.

#### 7.5. Installation of Anchor Rods, Foundation Bolts, and Other Embedded Items

7.5.1. *Anchor rods*, foundation bolts, and other embedded items shall be set by the *owner's designated representative for construction* in accordance with *embedment drawings* that have been approved by the *owner's designated representatives for design and construction*. The variation in location of these items from the dimensions shown in the approved *embedment drawings* shall be as follows:

- (a) The vertical variation in location from the specified top of *anchor rod* location shall be equal to or less than plus or minus  $\frac{1}{2}$  in. (13 mm).
- (b) The horizontal variation in location from the specified position of each *anchor rod* centerline at any location along its projection above the concrete shall be equal to or less than the dimensions given for the *anchor rod* diameters listed as follows:

Anchor Rod Diameter, in. (mm)	Horizontal Variation, in. (mm)
$\frac{3}{4}$ and $\frac{7}{8}$ (19 and 22)	$\frac{1}{4}$ (6)
1, $1\frac{1}{4}$ , $1\frac{1}{2}$ (25, 31, 38)	$\frac{3}{8}$ (10)
$1\frac{3}{4}$ , 2, $2\frac{1}{2}$ (44, 50, 63)	$\frac{1}{2}$ (13)

##### Commentary:

The tolerances established in this Section have been selected for compatibility with the holes sizes that are recommended for base plates in the *AISC Steel Construction Manual*. If special conditions require more restrictive tolerances, such as for smaller holes, the required tolerances should be stated in the *contract documents*. When the *anchor rods* are set in sleeves, the adjustment provided may be used to satisfy the required *anchor-rod* setting tolerances.

7.5.2. Unless otherwise specified in the *contract documents*, *anchor rods* shall be set with their longitudinal axis perpendicular to the theoretical bearing surface.

7.5.3. Embedded items and *connection* materials that are part of the work of other trades, but that will receive *structural steel*, shall be located and set by the *owner's designated representative for construction* in accordance with an approved *embedment drawing*. The variation in location of these items shall be limited to a magnitude that is consistent with the tolerances that are specified in Section 7.13 for the erection of the *structural steel*.

- 7.5.4. All work that is performed by the *owner's designated representative for construction* shall be completed so as not to delay or interfere with the work of the *fabricator* and the *erector*. The *owner's designated representative for construction* shall conduct a survey of the as-built locations of *anchor rods*, foundation bolts and other embedded items, and shall verify that all items covered in Section 7.5 meet the corresponding tolerances. When corrective action is necessary, the *owner's designated representative for construction* shall obtain the guidance and approval of the *owner's designated representative for design*.

**Commentary:**

Few *fabricators* or *erectors* have the capability to provide this survey. Under standard practice, it is the responsibility of others.

## 7.6. Installation of Bearing Devices

All leveling plates, leveling nuts and washers, and loose base and bearing plates that can be handled without a derrick or crane are set to line and grade by the *owner's designated representative for construction*. Loose base and bearing plates that require handling with a derrick or crane shall be set by the *erector* to lines and grades established by the *owner's designated representative for construction*. The *fabricator* shall clearly scribe loose base and bearing plates with lines or other suitable marks to facilitate proper alignment.

Promptly after the setting of *bearing devices*, the *owner's designated representative for construction* shall check them for line and grade. The variation in elevation relative to the established grade for all *bearing devices* shall be equal to or less than plus or minus  $\frac{1}{8}$  in. (3 mm). The final location of *bearing devices* shall be the responsibility of the *owner's designated representative for construction*.

**Commentary:**

The  $\frac{1}{8}$  in. (3 mm) tolerance on elevation of *bearing devices* relative to established grades is provided to permit some variation in setting *bearing devices*, and to account for the accuracy that is attainable with standard surveying instruments. The use of leveling plates larger than 22 in. by 22 in. (550 mm by 550 mm) is discouraged and grouting is recommended with larger sizes. For the purposes of erection stability, the use of leveling nuts and washers is discouraged when base plates have less than four *anchor rods*.

## 7.7. Grouting

Grouting shall be the responsibility of the *owner's designated representative for construction*. Leveling plates and loose base and bearing plates shall be promptly grouted after they are set and checked for line and grade. Columns with attached base plates, beams with attached bearing plates and other similar members with attached *bearing devices* that are temporarily supported on leveling nuts and washers, shims or other similar leveling devices, shall be promptly grouted after the *structural steel* frame or portion thereof has been plumbed.

**Commentary:**

In the majority of structures the vertical load from the column bases is transmitted to the foundations through structural grout. In general, there are three methods by which support is provided for column bases during erection:

- (a) Pre-grouted leveling plates or loose base plates.
- (b) Shims.
- (c) Leveling nuts and washers on the *anchor rods* beneath the column base.

Standard practice provides that loose base plates and leveling plates are to be grouted as they are set. *Bearing devices* that are set on shims or leveling nuts are grouted after plumbing, which means that the weight of the erected *structural steel* frame is supported on the shims or washers, nuts and *anchor rods*. The *erector* must take care to ensure that the load that is transmitted in this temporary condition does not exceed the strength of the shims or washers, nuts and *anchor rods*. These considerations are presented in greater detail in AISC Design Guide 1, *Base Plate and Anchor Rod Design*, and AISC Design Guide 10, *Erection Bracing of Low-Rise Structural Steel Frames*.

**7.8. Field Connection Material**

- 7.8.1. The *fabricator* shall provide field *connection* details that are consistent with the requirements in the *contract documents* and that will, in the *fabricator's* opinion, result in economical fabrication and erection.
- 7.8.2. When the *fabricator* is responsible for erecting the *structural steel*, the *fabricator* shall furnish all materials that are required for both temporary and permanent *connection* of the component parts of the *structural steel* frame.
- 7.8.3. When the erection of the *structural steel* is not performed by the *fabricator*, the *fabricator* shall furnish the following field *connection* material:
  - (a) Bolts, nuts and washers in sufficient quantity for all *structural steel-to-structural steel* field *connections* that are to be permanently bolted. The *fabricator* shall include an extra 2% plus 3 bolts, subject to a minimum of 5 extra bolts, of each grade, type, diameter, length, and production lot number.
  - (b) Shims that are shown as necessary for make-up of permanent *structural steel-to-structural steel* field *connections*.
  - (c) Steel backing and run-off tabs that are required for field welding.
- 7.8.4. The *erector* shall furnish all welding electrodes, fit-up bolts and drift pins used for the erection of the *structural steel*. Non-steel backing, if used, shall be furnished by the *erector*.

**Commentary:**

See the Commentary for Section 2.2.

## 7.9. Loose Material

Unless otherwise specified in the *contract documents*, loose *structural steel* items that are not connected to the *structural steel* frame shall be set by the *owner's designated representative for construction* without assistance from the *erector*.

## 7.10. Temporary Support of Structural Steel Frames

7.10.1. The *owner's designated representative for design* shall identify the following in the *contract documents*:

- (a) The lateral force-resisting system and connecting diaphragm elements that provide for lateral strength and stability in the completed structure.
- (b) Any special erection conditions or other considerations that are required by the design concept, such as the use of shores, jacks or loads that must be adjusted as erection progresses to set or maintain camber, position within specified tolerances or prestress.

### Commentary:

The intent of Section 7.10.1 of the Code is to alert the *owner's designated representative for construction* and the *erector* of the means for lateral force resistance in the completed structure so that appropriate planning can occur for construction of the building. Examples of a description of the lateral force-resisting system as required in Section 7.10.1(a) are shown in the following.

Example 1 is an all-steel building with a composite metal deck and concrete floor system. All lateral force resistance is provided by welded moment frames in each orthogonal building direction. One suitable description of this lateral force-resisting system is:

*All lateral force resistance and stability of the building in the completed structure is provided by moment frames with welded beam to column connections framed in each orthogonal direction (see plan sheets for locations). The composite metal deck and concrete floors serve as horizontal diaphragms that distribute the lateral wind and seismic forces horizontally to the vertical moment frames. The vertical moment frames carry the applied lateral loads to the building foundation.*

Example 2 is a steel-framed building with a composite metal deck and concrete floor system. All beam-to-column *connections* are simple *connections* and all lateral force resistance is provided by reinforced concrete shear walls in the building core and in the stairwells. One suitable description of this lateral force-resisting system is:

*All lateral force resistance and stability of the building in the completed structure is provided exclusively by cast-in-place reinforced concrete shear walls in the building core and stairwells (see plan sheets for locations). These walls provide all lateral force resistance in each orthogonal building direction. The composite metal deck and concrete floors serve as horizontal diaphragms that distribute the lateral wind and seismic forces horizontally to the concrete shear walls. The concrete shear walls carry the applied lateral loads to the building foundation.*

See also Commentary Section 7.10.3.

Section 7.10.1(b) is intended to apply to special requirements inherent in the design concept that could not otherwise be known by the *erector*. Such conditions might include designs that require the use of shores or jacks to impart a load or to obtain a specific elevation or position in a subsequent step of the erection process in a sequentially erected structure or member. These requirements would not be apparent to an *erector*, and must be identified so the *erector* can properly bid, plan and perform the erection.

The *erector* is responsible for installation of all members (including cantilevered members) to the specified plumbness, elevation and alignment within the erection tolerances specified in this Code. The *erector* must provide all temporary supports and devices to maintain elevation or position within these tolerances. These works are part of the means and methods of the *erector* and the *owner's designated representative for design* need not specify these methods or related equipment.

See also the preset requirements for cantilevered members in Section 3.1.

- 7.10.2. The *owner's designated representative for construction* shall indicate to the *erector*, prior to bidding, the installation schedule for non-*structural steel* elements of the lateral force-resisting system and connecting diaphragm elements identified by the *owner's designated representative for design* in the *contract documents*.

**Commentary:**

See Commentary Section 7.10.3.

- 7.10.3. Based upon the information provided in accordance with Sections 7.10.1 and 7.10.2, the *erector* shall determine, furnish and install all temporary supports, such as temporary guys, beams, falsework, cribbing or other elements required for the erection operation. These temporary supports shall be sufficient to secure the bare *structural steel* framing or any portion thereof against loads that are likely to be encountered during erection, including those due to wind and those that result from erection operations.

The *erector* need not consider loads during erection that result from the performance of work by, or the acts of, others, except as specifically identified by the *owner's designated representatives for design* and *construction*, nor those that are unpredictable, such as loads due to hurricane, tornado, earthquake, explosion or collision.

Temporary supports that are required during or after the erection of the *structural steel* frame for the support of loads caused by non-*structural steel* elements, including cladding, interior partitions and other such elements that will induce or transmit loads to the *structural steel* frame during or after erection, shall be the responsibility of others.

**Commentary:**

Many *structural steel* frames have lateral force-resisting systems that are activated during the erection process. Such lateral force-resisting systems may consist of



welded moment frames, braced frames or, in some instances, columns that cantilever from fixed-base foundations. Such frames are normally braced with temporary guys that, together with the steel deck floor and roof diaphragms or other diaphragm bracing that may be included as part of the design, provide stability during the erection process. The guy cables are also commonly used to plumb the *structural steel* frame. The *erector* normally furnishes and installs the required temporary supports and bracing to secure the bare *structural steel* frame, or portion thereof, during the erection process. When *erection bracing drawings* are required in the *contract documents*, those drawings show this information.

If the *owner's designated representative for construction* determines that steel decking is not installed by the *erector*, temporary diaphragm bracing may be required if a horizontal diaphragm is not available to distribute loads to the vertical and lateral force-resisting system. If the steel deck will not be available as a diaphragm during *structural steel* erection, the *owner's designated representative for construction* must communicate this condition to the *erector* prior to bidding. If such diaphragm bracing is required, it must be furnished and installed by the *erector*.

Sometimes structural systems that are employed by the *owner's designated representative for design* rely upon other elements besides the *structural steel* frame for lateral force resistance. For instance, concrete or masonry shear walls or precast spandrels may be used to provide resistance to vertical and lateral forces in the completed structure. Because these situations may not be obvious to the contractor or the *erector*, it is required in this Code that the *owner's designated representative for design* must identify such situations in the *contract documents*. Similarly, if a structure is designed so that special erection techniques are required, such as jacking to impose certain loads or position during erection, it is required in this Code that such requirements be specifically identified in the *contract documents*.

In some instances, the *owner's designated representative for design* may elect to show erection bracing in the *structural design documents*. When this is the case, the *owner's designated representative for design* should then confirm that the bracing requirements were understood by review and approval of the *erection documents* during the submittal process.

Sometimes during construction of a building, collateral building elements, such as exterior cladding, may be required to be installed on the bare *structural steel* frame prior to completion of the lateral force-resisting system. These elements may increase the potential for lateral loads on the temporary supports. Such temporary supports may also be required to be left in place after the *structural steel* frame has been erected. Special provisions should be made by the *owner's designated representative for construction* for these conditions.

- 7.10.4. All temporary supports that are required for the erection operation and furnished and installed by the *erector* shall remain the property of the *erector* and shall not be modified, moved or removed without the consent of the *erector*. Temporary supports provided by the *erector* shall remain in place until the portion of the *structural steel* frame that they brace is complete and the lateral force-resisting system and connecting

diaphragm elements identified by the *owner's designated representative for design* in accordance with Section 7.10.1 are installed. Temporary supports that are required to be left in place after the completion of *structural steel* erection shall be removed when no longer needed by the *owner's designated representative for construction* and returned to the *erector* in good condition.

### 7.11. Safety Protection

- 7.11.1. The *erector* shall provide floor coverings, handrails, walkways and other safety protection for the *erector's* personnel as required by law and the applicable safety regulations. Unless otherwise specified in the *contract documents*, the *erector* is permitted to remove such safety protection from areas where the erection operations are completed.
- 7.11.2. When safety protection provided by the *erector* is left in an area for the use of other trades after the *structural steel* erection activity is completed, the *owner's designated representative for construction* shall:
- (a) Accept responsibility for and maintain this protection.
  - (b) Indemnify the *fabricator* and the *erector* from damages that may be incurred from the use of this protection by other trades.
  - (c) Ensure that this protection is adequate for use by other affected trades.
  - (d) Ensure that this protection complies with applicable safety regulations when being used by other trades.
  - (e) Remove this protection when it is no longer required and return it to the *erector* in the same condition as it was received.
- 7.11.3. Safety protection for other trades that are not under the direct employment of the *erector* shall be the responsibility of the *owner's designated representative for construction*.
- 7.11.4. When permanent steel decking is used for protective flooring and is installed by the *owner's designated representative for construction*, all such work shall be scheduled and performed in a timely manner so as not to interfere with or delay the work of the *fabricator* or the *erector*. The sequence of installation that is used shall meet all safety regulations.
- 7.11.5. Unless the interaction and safety of activities of others, such as construction by others or the storage of materials that belong to others, are coordinated with the work of the *erector* by the *owner's designated representative for construction*, such activities shall not be permitted until the erection of the *structural steel* frame or portion thereof is completed by the *erector* and accepted by the *owner's designated representative for construction*.

### 7.12. Structural Steel Frame Tolerances

The accumulation of the mill tolerances and fabrication tolerances shall not cause the erection tolerances to be exceeded.

**Commentary:**

In editions of this Code previous to the 2005 edition, it was stated that "...variations are deemed to be within the limits of good practice when they do not exceed the cumulative effect of rolling tolerances, fabricating tolerances and erection tolerances." It is recognized in the current provision in this Section that accumulations of mill tolerances and fabrication tolerances generally occur between the locations at which erection tolerances are applied, and not at the same locations.

**7.13. Erection Tolerances**

Erection tolerances shall be defined relative to member working points and working lines, which shall be defined as follows:

- (a) For members other than horizontal members, the member work point shall be the actual center of the member at each end of the shipping piece.
- (b) For horizontal members, the working point shall be the actual centerline of the top flange or top surface at each end.
- (c) The member working line shall be the straight line that connects the member working points.

The substitution of other working points is permitted for ease of reference, provided they are based upon the preceding definitions.

The tolerances on *structural steel* erection shall be in accordance with the requirements in Sections 7.13.1 through 7.13.3.

**Commentary:**

The erection tolerances defined in this Section have been developed through long-standing usage as practical criteria for the erection of *structural steel*. Erection tolerances were first defined in the 1924 edition of this Code in Section 7(f), "Plumbing Up." With the changes that took place in the types and use of materials in building construction after World War II, and the increasing demand by *architects* and *owners* for more specific tolerances, AISC adopted new standards for erection tolerances in Section 7(h) of the March 15, 1959 edition of this Code. Experience has proven that those tolerances can be economically obtained.

Differential column shortening may be a consideration in design and construction. In some cases, it may occur due to variability in the accumulation of dead load among different columns (see Figure C-7.1). In other cases, it may be characteristic of the structural system that is employed in the design. Consideration of the effects of differential column shortening may be very important, such as when the slab thickness is reduced, when electrical and other similar fittings mounted on the *structural steel* are intended to be flush with the finished floor, and when there is little clearance between bottoms of beams and the tops of door frames or ductwork.

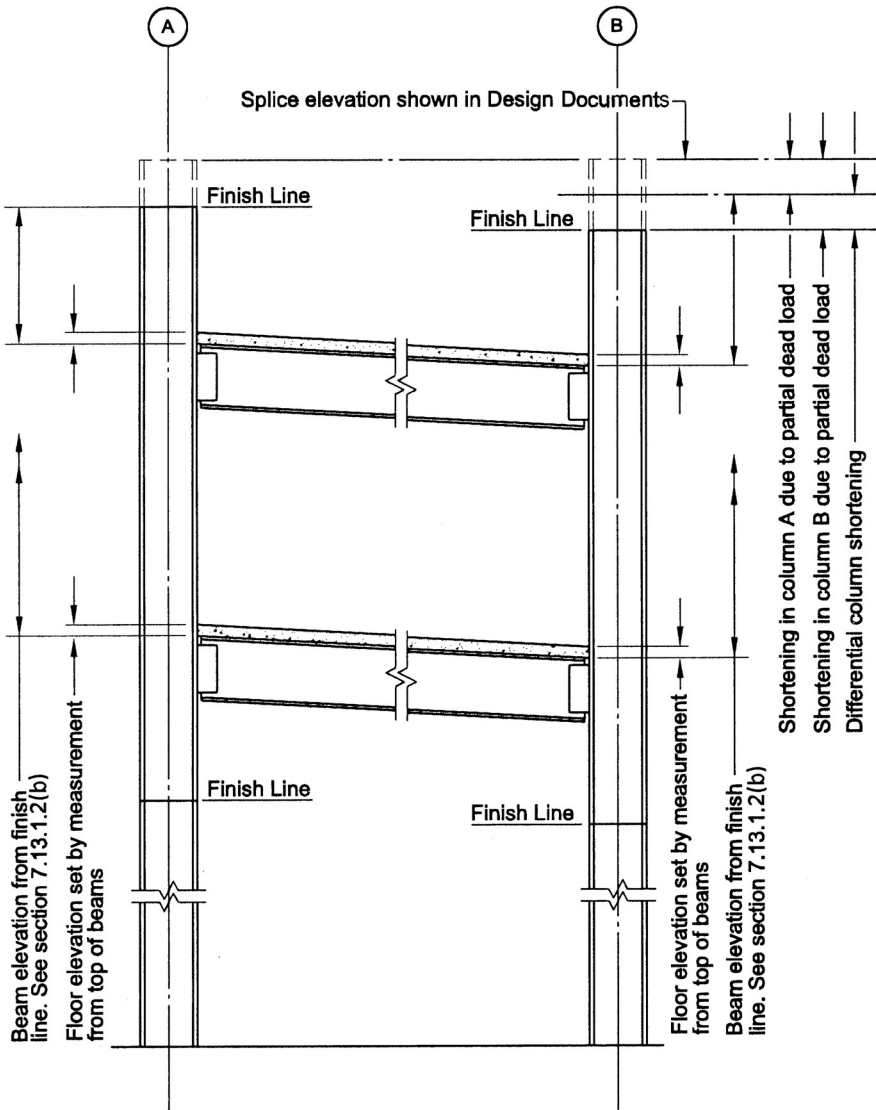

Fig. C-7.1. Effects of differential column shortening.

The effects of the deflection of transfer girders and trusses on the position of columns and hangers supported from them may be a consideration in design and construction. As in the case of differential column shortening, the deflection of these supporting members during and after construction will affect the position and alignment of the framing tributary to these transfer members.

Expansion and contraction in a *structural steel* frame may be a consideration in design and construction. Steel will expand or contract approximately

$\frac{1}{8}$  in. per 100 ft for each change of 15°F (2 mm per 10 000 mm for each change of 15°C) in temperature. This change in length can be assumed to act about the center of rigidity. When anchored to their foundations, end columns will be plumb only when the steel is at normal temperature (see Figure C-7.2). It is therefore necessary to correct field measurements of offsets to the structure from established baselines for the expansion or contraction of the exposed *structural steel* frame. For example, a 200-ft-long (60 000-m-long) building that is plumbed up at 100°F (38°C) should have working points at the tops of the end columns positioned  $\frac{1}{2}$  in. (14 mm) further apart than the working points at the corresponding bases in order for the columns to be plumb at 70°F (21°C). Differential temperature effects on column length should also be taken into account in plumbing surveys when tall *structural steel* frames are subjected to sun exposure on one side.

The alignment of lintels, spandrels, wall supports and similar members that are used to connect other building construction units to the *structural steel* frame should have an adjustment of sufficient magnitude to allow for the accumulation of mill tolerances and fabrication tolerances, as well as the erection tolerances. See Figure C-7.3.

- 7.13.1. The tolerances on position and alignment of member working points and working lines shall be as described in Sections 7.13.1.1 through 7.13.1.3.
- 7.13.1.1. For an individual column shipping piece, the angular variation of the working line from a plumb line shall be equal to or less than  $\frac{1}{500}$  of the distance between working points, subject to the following additional limitations:
- For an individual column shipping piece that is adjacent to an elevator shaft, the displacement of member working points shall be equal to or less than 1 in. (25 mm) from the *established column line* in the first 20 stories. Above this level, an increase in the displacement of  $\frac{1}{32}$  in. (1 mm) is permitted for each additional story up to a maximum displacement of 2 in. (50 mm) from the *established column line*.
  - For an exterior individual column shipping piece, the displacement of member working points from the *established column line* in the first 20 stories shall be equal to or less than 1 in. (25 mm) toward and 2 in. (50 mm) away from the building exterior. Above this level, an increase in the displacement of  $\frac{1}{16}$  in. (2 mm) is permitted for each additional story up to a maximum displacement of 2 in. (50 mm) toward and 3 in. (75 mm) away from the building exterior.

**Commentary:**

The limitations that are described in this Section and illustrated in Figures C-7.4 and C-7.5 make it possible to maintain built-in-place or prefabricated facades in a true vertical plane up to the 20th story, if *connections* that provide for 3 in. (75 mm) of adjustment are used. Above the 20th story, the facade may be maintained within  $\frac{1}{16}$  in. (2 mm) per story with a maximum total deviation of 1 in. (25 mm) from a true vertical plane, if *connections* that

When plumbing columns, apply a temperature adjustment at a rate of 1/8 in. per 100 ft. for each change of 15°F [2 mm per 10 000 mm for each change of 15°C] between the temperature at the time of erection and the working temperature.

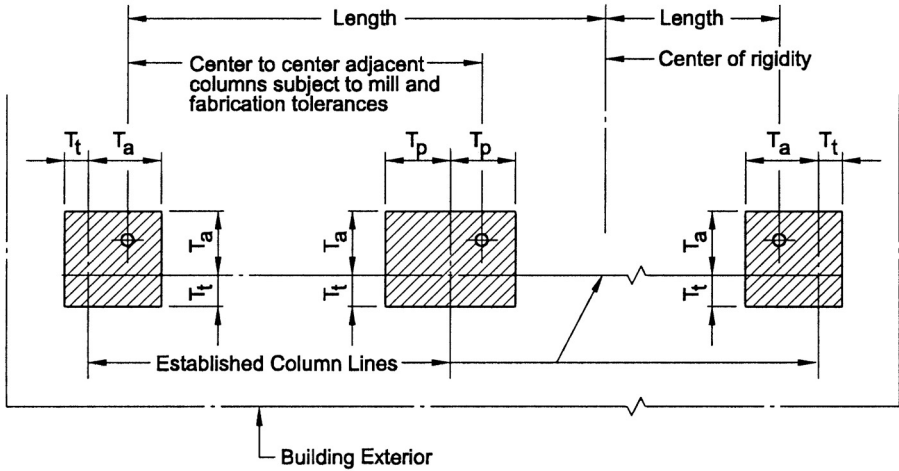
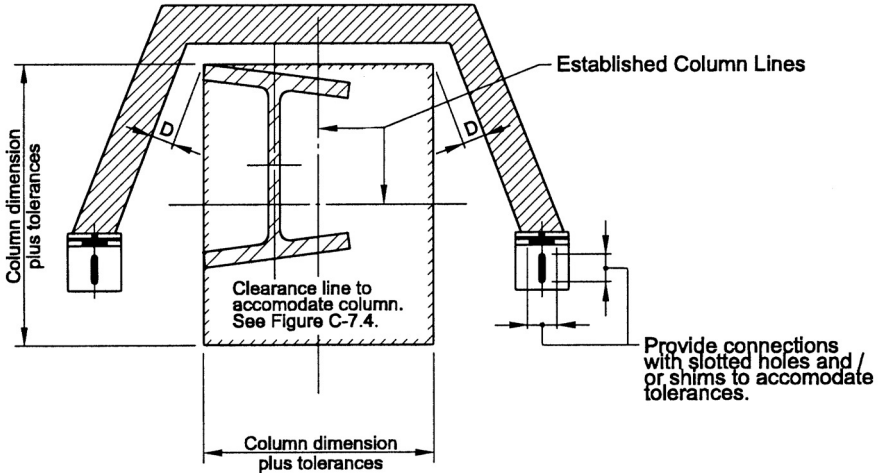

Fig. C-7.2. Tolerances in plan location of column.



If fascia joints are set from nearest column finish line, allow  $\pm 5/8$  in. [16mm] for vertical adjustment. The entity responsible for the fascia details must allow for progressive shortening of steel columns.

D= Tolerances required by manufacturer of wall units plus survey tolerances.

Fig. C-7.3. Clearance required to accommodate fascia.

provide for 3 in. (75 mm) of adjustment are used. *Connections* that permit adjustments of plus 2 in. (50 mm) to minus 3 in. (75 mm)—a total of 5 in. (125 mm)—will be necessary in cases where it is desired to construct the facade to a true vertical plane above the 20th story.

- (c) For an exterior individual column shipping piece, the member working points at any splice level for multi-tier buildings and at the tops of columns for single-tier buildings shall fall within a horizontal envelope, parallel to the exterior *established column line*, that is equal to or less than 1½ in. (38 mm) wide for buildings up to 300 ft (90 000 mm) in length. An increase in the width of this horizontal envelope of ½ in. (13 mm) is permitted for each additional 100 ft (30 000 mm) in length up to a maximum width of 3 in. (75 mm).

**Commentary:**

This Section limits the position of exterior column working points at any given splice elevation to a narrow horizontal envelope parallel to the exterior *established column line* (see Figure C-7.6). This envelope is limited to a width of 1½ in. (38 mm), normal to the exterior *established column line*, in up to 300 ft (90 000 mm) of building length. The horizontal location of this envelope is not necessarily directly above or below the corresponding envelope at the adjacent splice elevations, but should be within the limitation of the 1 in 500 plumbness tolerance specified for the controlling columns (see Figure C-7.5).

- (d) For an exterior column shipping piece, the displacement of member working points from the *established column line* that is nominally parallel to the building exterior shall be equal to or less than 2 in. (50 mm) in the first 20 stories. Above this level, an increase in the displacement of 1/16 in. (2 mm) is permitted for each additional story up to a maximum displacement of 3 in. (75 mm) in the direction nominally parallel to the building exterior.

7.13.1.2. For members other than column shipping pieces, the following limitations shall apply:

- (a) For a member that consists of an individual, straight shipping piece without field splices, other than a cantilevered member, the variation in alignment shall be acceptable if it is caused solely by variations in column alignment and/or primary supporting member alignment that are within the permissible variations for the fabrication and erection of such members.
- (b) For a member that consists of an individual, straight shipping piece that connects to a column, the variation in the distance from the member working point to the upper finished splice line of the column shall be equal to or less than plus 3/16 in. (5 mm) and minus 5/16 in. (8 mm).
- (c) For a member that consists of an individual shipping piece that does not connect to a column, the variation in elevation shall be acceptable if it is caused solely by the variations in the elevations of the supporting members within the permissible variations for the fabrication and erection of those members.

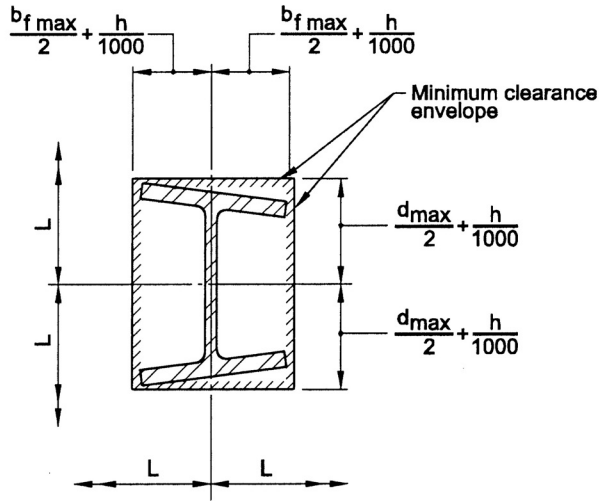

For enclosures or attachments that may follow column alignment.

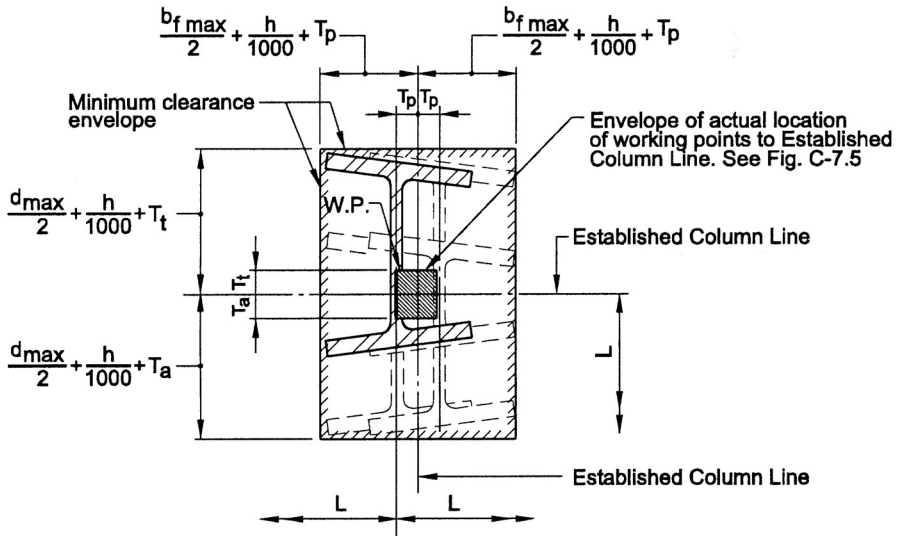

For enclosures or attachments that must be held to precise plan location.

- $L$  = Actual center to center of columns = plan dimensions  $\pm$  column cross section tolerance of columns  $\pm$  beam length tolerance.
- $T_a$  = Plumbness tolerance away from building exterior (varies, see Fig. C-7.5)
- $T_t$  = Plumbness tolerance toward building exterior (varies, see Fig. C-7.5)
- $T_p$  = Plumbness tolerance parallel to building exterior ( $=T_a$ )

Fig. C-7.4. Clearance required to accommodate accumulated column tolerance.



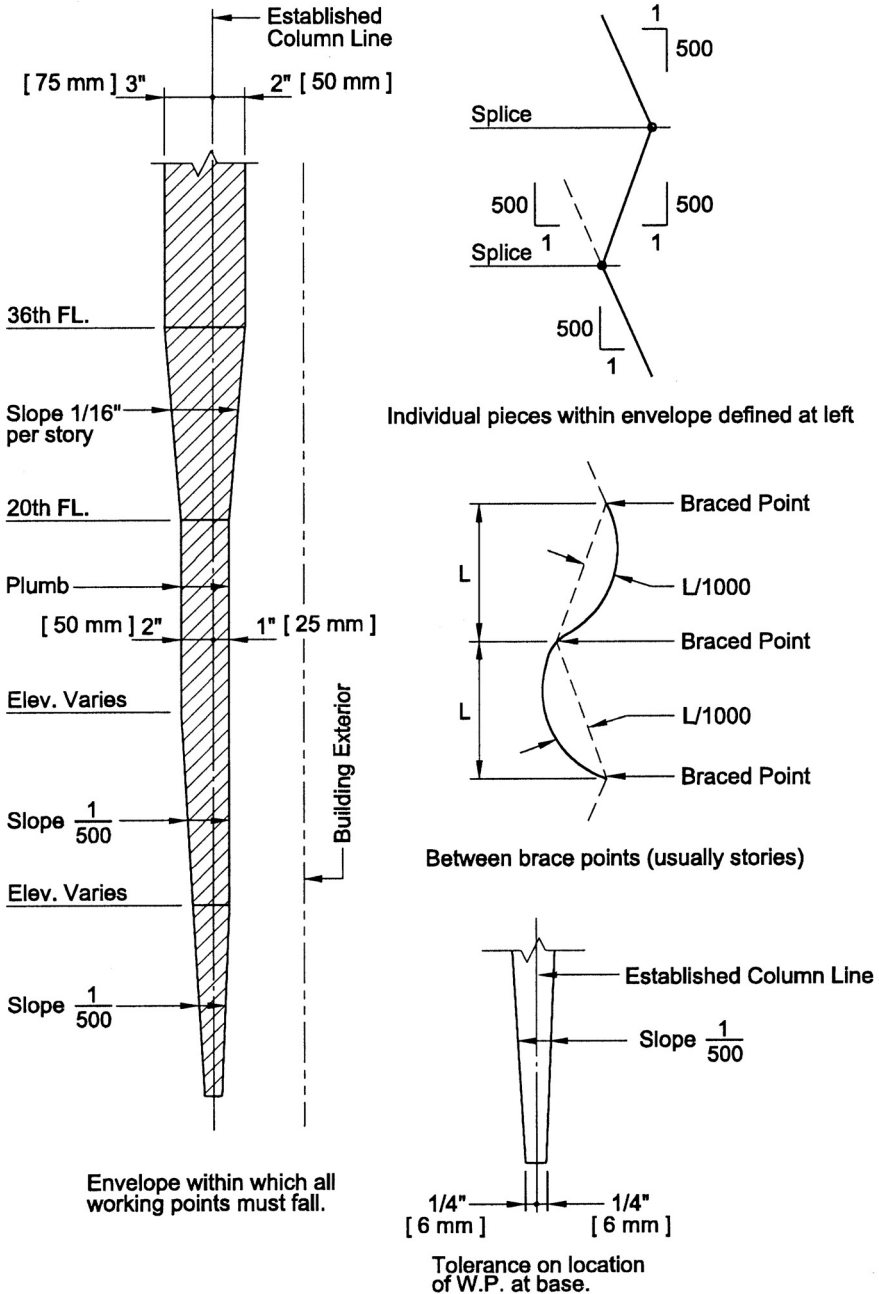

Note: The plumb line through the base working point for an individual column is not necessarily the precise plan location because Sect. 7.13.1.1 deals only with plumbness tolerances and does not include inaccuracies in location of the Established Column Line, foundations and anchor rods beyond the Erector's control

Fig. C-7.5. Exterior column plumbness tolerances normal to building exterior.

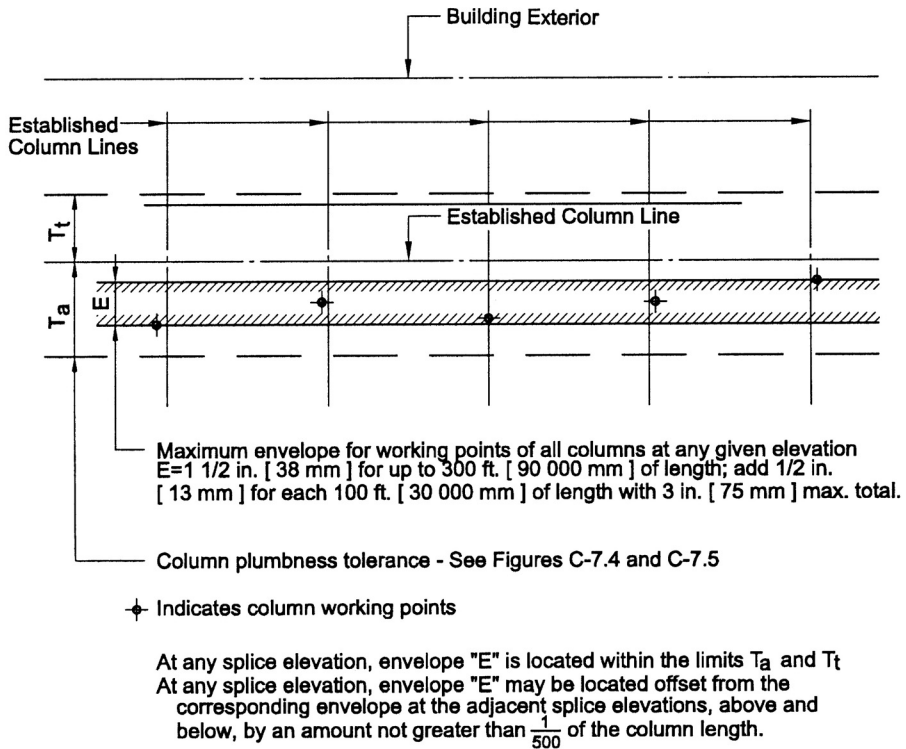

Fig. C-7.6. Tolerances in plan at any splice elevation of exterior columns.

- (d) For a member that consists of an individual, straight shipping piece and that is a segment of a field assembled unit containing field splices between points of support, the plumbness, elevation and alignment shall be acceptable if the angular variation, vertically and horizontally, of the working line from a straight line between points of support is equal to or less than  $1/500$  of the distance between working points.

**Commentary:**

The angular misalignment of the working line of all fabricated shipping pieces relative to the line between support points of the member as a whole in erected position must not exceed 1 in 500. Note that the tolerance is not stated in terms of a linear displacement at any point and is not to be taken as the overall length between supports divided by 500. Typical examples are shown in Figure C-7.7. Numerous conditions within tolerance for these and other cases are possible. The condition described in (d) applies to both plan and elevation tolerances.

- (e) For a cantilevered member that consists of an individual, straight shipping piece, the plumbness, elevation and alignment shall be acceptable if the

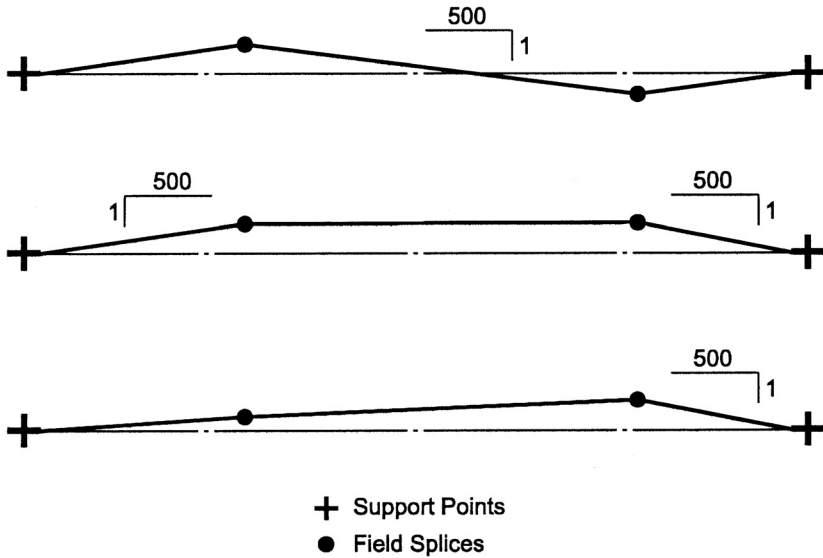

Fig. C-7.7. Alignment tolerances for members with field splices.

angular variation of the working line from a straight line that is extended in the plan direction from the working point at its supported end is equal to or less than  $1/500$  of the distance from the working point at the free end.

**Commentary:**

This tolerance is evaluated after the fixed end condition is sufficient to stabilize the cantilever and before the temporary support is removed. The preset specified in the *contract documents* should be calculated accordingly. The temporary support cannot be used to induce artificial deflection into the cantilever to meet this tolerance after the fixed end is restrained.

- (f) For a member of irregular shape, the plumbness, elevation and alignment shall be acceptable if the fabricated member is within its tolerances and the members that support it are within the tolerances specified in this Code.
- (g) For a member that is fully assembled in the field in an unstressed condition, the same tolerances shall apply as if fully assembled in the shop.
- (h) For a member that is field-assembled, element-by-element, in place, temporary support shall be used or an alternative erection plan shall be submitted to the *owner's designated representatives for design and construction*. The tolerance in Section 7.13.1.2(d) shall be met in the supported condition with working points taken at the point(s) of temporary support.

**Commentary:**

Trusses fabricated and erected as a unit or as an assembly of truss segments

normally have excellent controls on vertical position regardless of fabrication and erection techniques. However, a truss fabricated and erected by assembling individual components in place in the field is potentially more sensitive to deflections of the individual truss components and the partially completed work during erection, particularly the chord members. In such a case, the erection process should follow an erection plan that addresses this issue.

7.13.1.3. For members that are identified as *adjustable items* by the *owner's designated representative for design* in the *contract documents*, the *fabricator* shall provide adjustable *connections* for these members to the supporting *structural steel* frame. Otherwise, the *fabricator* is permitted to provide nonadjustable *connections*. When *adjustable items* are specified, the *owner's designated representative for design* shall indicate the total adjustability that is required for the proper alignment of these supports for other trades. The variation in the position and alignment of *adjustable items* shall be as follows:

- (a) The variation in the vertical distance from the upper finished splice line of the nearest column to the support location specified in the *structural design documents* shall be equal to or less than plus or minus  $\frac{3}{8}$  in. (10 mm).
- (b) The variation in the horizontal distance from the established finish line at the particular floor shall be equal to or less than plus or minus  $\frac{3}{8}$  in. (10 mm).
- (c) The variation in vertical and horizontal alignment at the abutting ends of *adjustable items* shall be equal to or less than plus or minus  $\frac{3}{16}$  in. (5 mm).

**Commentary:**

When the alignment of lintels, wall supports, curb angles, mullions and similar supporting members for the use of other trades is required to be closer than that permitted by the foregoing tolerances for *structural steel*, the *owner's designated representative for design* must identify such items in the *contract documents* as *adjustable items*.

7.13.2. In the design of steel structures, the *owner's designated representative for design* shall provide for the necessary clearances and adjustments for material furnished by other trades to accommodate the mill tolerances, fabrication tolerances and erection tolerances in this Code for the *structural steel* frame.

**Commentary:**

In spite of all efforts to minimize inaccuracies, deviations will still exist; therefore, in addition, the designs of prefabricated wall panels, partition panels, fenestrations, floor-to-ceiling door frames, and similar elements must provide for clearance and details for adjustment as described in Section 7.13.2. Designs must provide for adjustment in the vertical dimension of prefabricated facade

panels that are supported by the *structural steel* frame because the accumulation of shortening of loaded steel columns will result in the unstressed facade supported at each floor level being higher than the *structural steel* framing to which it must be attached. Observations in the field have shown that where a heavy facade is erected to a greater height on one side of a multistory building than on the other, the *structural steel* framing will be pulled out of alignment. Facades should be erected at a relatively uniform rate around the perimeter of the structure.

- 7.13.3. Prior to placing or applying any other materials, the *owner's designated representative for construction* shall determine that the location of the *structural steel* is acceptable for plumbness, elevation and alignment. The *erector* shall be given either timely notice of acceptance by the *owner's designated representative for construction* or a listing of specific items that are to be corrected in order to obtain acceptance. Such notice shall be rendered promptly upon completion of any part of the work and prior to the start of work by other trades that may be supported, attached or applied to the *structural steel* frame.

#### 7.14. Correction of Errors

The correction of minor misfits by moderate amounts of reaming, grinding, welding or cutting, and the drawing of elements into line with drift pins, shall be considered to be normal erection operations. Errors that cannot be corrected using the foregoing means, or that require major changes in member or *connection* configuration, shall be promptly reported to the *owner's designated representatives for design and construction* and the *fabricator* by the *erector*, to enable the responsible entity to either correct the error or approve the most efficient and economical method of correction to be used by others.

##### Commentary:

As used in this Section, the term “moderate” refers to the amount of reaming, grinding, welding or cutting that must be done on the project as a whole, not the amount that is required at an individual location. It is not intended to address limitations on the amount of material that is removed by reaming at an individual bolt hole, for example, which is limited by the bolt-hole size and tolerance requirements in ANSI/AISC 360 and the RCSC Specification.

#### 7.15. Cuts, Alterations and Holes for Other Trades

Neither the *fabricator* nor the *erector* shall cut, drill or otherwise alter their work, nor the work of other trades, to accommodate other trades, unless such work is clearly specified in the *contract documents*. When such work is so specified, the *owner's designated representatives for design and construction* shall furnish complete information as to materials, size, location and number of alterations in a timely manner so as not to delay the preparation of the *approval documents*.

## 7.16. Handling and Storage

The *erector* shall take reasonable care in the proper handling and storage of the *structural steel* during erection operations to avoid the accumulation of excess dirt and foreign matter. The *erector* shall not be responsible for the removal from the *structural steel* of dust, dirt or other foreign matter that may accumulate during erection as the result of job-site conditions or exposure to the elements. The *erector* shall handle and store all bolts, nuts, washers and related fastening products in accordance with the requirements of the RCSC Specification.

### **Commentary:**

During storage, loading, transport, unloading and erection, blemish marks caused by slings, chains, blocking, tie-downs, etc., occur in varying degrees. Abrasions caused by handling or cartage after painting are to be expected. It must be recognized that any shop-applied coating, no matter how carefully protected, will require touching up in the field. Touching up these blemished areas is the responsibility of the contractor performing the field touch-up or field painting.

The *erector* is responsible for the proper storage and handling of fabricated *structural steel* at the job site during erection. Shop-painted *structural steel* that is stored in the field pending erection should be kept free of the ground and positioned so as to minimize the potential for water retention. The *owner* or *owner's designated representative for construction* is responsible for providing suitable job-site conditions and proper access so that the *fabricator* and the *erector* may perform their work.

Job-site conditions are frequently muddy, sandy, dusty or a combination thereof during the erection period. Under such conditions, it may be impossible to store and handle the *structural steel* in such a way as to completely avoid any accumulation of mud, dirt or sand on the surface of the *structural steel*, even though the *fabricator* and the *erector* manages to proceed with their work.

Repairs of damage to painted surfaces and/or removal of foreign materials due to adverse job-site conditions are outside the scope of responsibility of the *fabricator* and the *erector* when reasonable attempts at proper handling and storage have been made.

## 7.17. Field Painting

Neither the *fabricator* nor the *erector* is responsible to paint field bolt heads and nuts or field welds, nor to touch up abrasions of the shop coat, nor to perform any other field painting.

## 7.18. Final Cleaning Up

Upon the completion of erection and before final acceptance, the *erector* shall remove all of the *erector's* falsework, rubbish and temporary buildings.

## SECTION 8. QUALITY CONTROL

### 8.1. General

- 8.1.1. The *fabricator* shall maintain a quality control program to ensure that the work is performed in accordance with the requirements in this Code, ANSI/AISC 360 and the *contract documents*. The *fabricator* shall have the option to use the AISC Quality Certification Program to establish and administer the quality control program.

**Commentary:**

The AISC Quality Certification Program confirms to the construction industry that a certified *structural steel* fabrication shop has the capability by reason of commitment, personnel, organization, experience, procedures, knowledge and equipment to produce fabricated *structural steel* of the required quality for a given category of work. The AISC Quality Certification Program is not intended to involve inspection and/or judgment of product quality on individual projects. Neither is it intended to guarantee the quality of specific fabricated *structural steel* products.

- 8.1.2. The *erector* shall maintain a quality control program to ensure that the work is performed in accordance with the requirements in this Code, ANSI/AISC 360 and the *contract documents*. The *erector* shall be capable of performing the erection of the *structural steel*, and shall provide the equipment, personnel and management for the scope, magnitude and required quality of each project. The *erector* shall have the option to use the AISC Erector Certification Program to establish and administer the quality control program.

**Commentary:**

The AISC Erector Certification Program confirms to the construction industry that a certified *structural steel erector* has the capability by reason of commitment, personnel, organization, experience, procedures, knowledge and equipment to erect fabricated *structural steel* to the required quality for a given category of work. The AISC Erector Certification Program is not intended to involve inspection and/or judgment of product quality on individual projects. Neither is it intended to guarantee the quality of specific erected *structural steel* products.

- 8.1.3. When the *owner* requires more extensive quality control procedures, or independent inspection by qualified personnel, or requires that the *fabricator* must be certified under the AISC Quality Certification Program and/or requires that the *erector* must be certified under the AISC Erector Certification Program, this shall be clearly stated in the *contract documents*, including a definition of the scope of such inspection.

### 8.2. Inspection of Mill Material

Material test reports shall constitute sufficient evidence that the mill product satisfies material order requirements. The *fabricator* shall make a visual inspection of material that is received from the mill, but need not perform any material tests unless the *owner's designated representative for design* specifies in the *contract documents* that additional testing is to be performed at the *owner's* expense.

### 8.3. Nondestructive Testing

When nondestructive testing is required, the process, extent, technique and standards of acceptance shall be clearly specified in the *contract documents*.

### 8.4. Surface Preparation and Shop Painting Inspection

Inspection of surface preparation and shop painting shall be planned for the acceptance of each operation as the *fabricator* completes it. Inspection of the paint system, including material and thickness, shall be made promptly upon completion of the paint application. When wet-film thickness is to be inspected, it shall be measured during the application.

### 8.5. Independent Inspection

When inspection by personnel other than those of the *fabricator* and/or *erector* is specified in the contract documents, the requirements in Sections 8.5.1 through 8.5.6 shall be met.

- 8.5.1. The *fabricator* and the *erector* shall provide the *inspector* with access to all places where the work is being performed. A minimum of 24 hours notification shall be given prior to the commencement of work.
- 8.5.2. Inspection of shop work by the *inspector* shall be performed in the *fabricator's* shop to the fullest extent possible. Such inspections shall be timely, in-sequence and performed in such a manner as will not disrupt fabrication operations and will permit the repair of nonconforming work prior to any required painting while the material is still in-process in the fabrication shop.
- 8.5.3. Inspection of field work shall be promptly completed without delaying the progress or correction of the work.
- 8.5.4. Rejection of material or workmanship that is not in conformance with the *contract documents* shall be permitted at any time during the progress of the work. However, this provision shall not relieve the *owner* or the *inspector* of the obligation for timely, in-sequence inspections.
- 8.5.5. The *fabricator*, *erector*, and *owner's designated representatives for design and construction* shall be informed of deficiencies that are noted by the *inspector* promptly after the inspection. Copies of all reports prepared by the *inspector* shall be promptly given to the *fabricator*, *erector*, and *owner's designated representatives for design and construction*. The necessary corrective work shall be performed in a timely manner.
- 8.5.6. The *inspector* shall not suggest, direct or approve the *fabricator* or *erector* to deviate from the *contract documents* or the approved *approval documents*, or approve such deviation, without the written approval of the *owner's designated representatives for design and construction*.



## SECTION 9. CONTRACTS

### 9.1. Types of Contracts

- 9.1.1. For contracts that stipulate a lump sum price, the work that is required to be performed by the *fabricator* and the *erector* shall be completely defined in the *contract documents*.
- 9.1.2. For contracts that stipulate a price per pound, the scope of work that is required to be performed by the *fabricator* and the *erector*, the type of materials, the character of fabrication and the conditions of erection shall be based upon the *contract documents*, which shall be representative of the work to be performed.
- 9.1.3. For contracts that stipulate a price per item, the work that is required to be performed by the *fabricator* and the *erector* shall be based upon the quantity and the character of the items that are described in the *contract documents*.
- 9.1.4. For contracts that stipulate unit prices for various categories of *structural steel*, the scope of work that is required to be performed by the *fabricator* and the *erector* shall be based upon the quantity, character and complexity of the items in each category as described in the *contract documents*, and shall also be representative of the work to be performed in each category.
- 9.1.5. When an *allowance* for work is called for in the *contract documents* and the associated work is subsequently defined as to the quantity, complexity and timing of that work after the contract is executed, the contract price for this work shall be adjusted by change order.

#### **Commentary:**

*Allowances*, if used, are not a true definition of the cost of work to be performed. By nature, an *allowance* is only an estimate and placeholder in the bid. Once the actual work is defined, the actual cost can be provided. It must be recognized that the actual cost can be higher or lower than the *allowance*. See Section 9.4.

*Allowances* required by the *contract documents* or proposed by the bidder should be as thoroughly defined as practicable as to the distinct nature of the work covered by the *allowance*, including whether the *allowance* is to include materials only, fabrication costs and/or erection costs.

### 9.2. Calculation of Weights

Unless otherwise specified in the contract, for contracts stipulating a price per pound for fabricated *structural steel* that is delivered and/or erected, the quantities of materials for payment shall be determined by the calculation of the gross weight of materials as shown in the *fabrication documents*.

#### **Commentary:**

The standard procedure for calculation of weights that is described in this Code meets the need for a universally acceptable system for defining “pay weights” in contracts based upon the weight of delivered and/or erected materials. These

procedures permits the *owner* to easily and accurately evaluate price-per-pound proposals from potential suppliers and enables all parties to a contract to have a clear and common understanding of the basis for payment.

The procedure in this Code affords a simple, readily understood method of calculation that will produce pay weights that are consistent throughout the industry and that may be easily verified by the *owner*. While this procedure does not produce actual weights, it can be used by purchasers and suppliers to define a widely accepted basis for bidding and contracting for *structural steel*. However, any other system can be used as the basis for a contractual agreement. When other systems are used, both the supplier and the purchaser should clearly understand how the alternative procedure is handled.

- 9.2.1. The unit weight of steel shall be taken as 490 lb/ft<sup>3</sup> (7 850 kg/m<sup>3</sup>). The unit weight of other materials shall be in accordance with the manufacturer's published data for the specific product.
- 9.2.2. The weights of *standard structural shapes*, plates and bars shall be calculated on the basis of *fabrication documents* that show the actual quantities and dimensions of material to be fabricated, as follows:
- (a) The weights of all *standard structural shapes* shall be calculated using the nominal weight per ft (mass per m) and the detailed overall length.
  - (b) The weights of plates and bars shall be calculated using the detailed overall rectangular dimensions.
  - (c) When parts can be economically cut in multiples from material of larger dimensions, the weight shall be calculated on the basis of the theoretical rectangular dimensions of the material from which the parts are cut.
  - (d) When parts are cut from *standard structural shapes*, leaving a nonstandard section that is not useable on the same contract, the weight shall be calculated using the nominal weight per ft (mass per m) and the overall length of the *standard structural shapes* from which the parts are cut.
  - (e) Deductions shall not be made for material that is removed for cuts, copes, clips, blocks, drilling, punching, boring, slot milling, planing or weld joint preparation.
- 9.2.3. The items for which weights are shown in tables in the AISC *Steel Construction Manual* shall be calculated on the basis of the tabulated weights shown therein.
- 9.2.4. The weights of items that are not shown in tables in the AISC *Steel Construction Manual* shall be taken from the manufacturer's catalog and the manufacturer's shipping weight shall be used.

**Commentary:**

Many items that are weighed for payment purposes are not tabulated with weights in the AISC *Steel Construction Manual*. These include, but are not limited to, *anchor rods*, clevises, turnbuckles, sleeve nuts, recessed-pin nuts, cotter pins and similar devices.

- 9.2.5. The weights of shop or field weld metal and protective coatings shall not be included in the calculated weight for the purposes of payment.

### 9.3. Revisions to the Contract Documents

*Revisions* to the *contract documents* shall be confirmed by change order or extra work order. Unless otherwise noted, the issuance of a *revision* to the *contract documents* shall constitute authorization by the *owner* that the *revision* is *released for construction*. The contract price and schedule shall be adjusted in accordance with Sections 9.4 and 9.5.

### 9.4. Contract Price Adjustment

- 9.4.1. When the scope of work and responsibilities of the *fabricator* and the *erector* are changed from those previously established in the *contract documents*, an appropriate modification of the contract price shall be made. In computing the contract price adjustment, the *fabricator* and the *erector* shall consider the quantity of work that is added or deleted, the modifications in the character of the work, and the timeliness of the change with respect to the status of material ordering, detailing, fabrication and erection operations.

#### **Commentary:**

The fabrication and erection of *structural steel* is a dynamic process. Typically, material is being acquired at the same time that the *approval documents* are being prepared. Additionally, the fabrication shop will normally fabricate pieces in the order that the *structural steel* is being shipped and erected.

Items that are revised or placed on hold generally upset these relationships and can be very disruptive to the digital modeling/detailing, fabricating and erecting processes. The provisions in Sections 3.5, 4.4.2 and 9.3 are intended to minimize these disruptions so as to allow work to continue. Accordingly, it is required in this Code that the reviewer of requests for contract price adjustments recognize this and allow compensation to the *fabricator* and the *erector* for these inefficiencies and for the materials that are purchased and the detailing, fabrication and erection that has been performed, when affected by the change.

- 9.4.2. Requests for contract price adjustments shall be presented by the *fabricator* and/or the *erector* in a timely manner and shall be accompanied by a description of the change that is sufficient to permit evaluation and timely approval by the *owner*.
- 9.4.3. Price-per-pound and price-per-item contracts shall provide for additions or deletions to the quantity of work that are made prior to the time the work is *released for construction*. When changes are made to the character of the work at any time, or when additions and/or deletions are made to the quantity of the work after it is released for detailing, fabrication or erection, the contract price shall be equitably adjusted.

### 9.5. Scheduling

- 9.5.1. The contract schedule shall state when the *design documents* will be *released for construction*, if the *design documents* are not available at the time of bidding, and when the job site, foundations, piers and abutments will be ready, free from obstructions and accessible to the *erector*, so that erection can start at the designated time and continue without interference or delay caused by the *owner's designated representative for construction* or other trades.

- 9.5.2. The *fabricator* and the *erector* shall advise the *owner's designated representatives for design and construction*, in a timely manner, of the effect any *revision* has on the contract schedule.
- 9.5.3. If the fabrication or erection is significantly delayed due to *revisions* to the requirements of the contract, or for other reasons that are the responsibility of others, the *fabricator* and/or *erector* shall be compensated for the additional costs incurred.

## 9.6. Terms of Payment

The *fabricator* shall be paid for *mill materials* and fabricated product that is stored off the job site. Other terms of payment for the contract shall be outlined in the *contract documents*.

### **Commentary:**

These terms include such items as progress payments for material, fabrication, erection, retainage, performance and payment bonds, and final payment. If a performance or payment bond, paid for by the *owner*, is required by contract, no retainage shall be required.

## SECTION 10. ARCHITECTURALLY EXPOSED STRUCTURAL STEEL

### 10.1. General Requirements

When members are specifically designated as *architecturally exposed structural steel* or *AESS* in the *contract documents*, the requirements in Sections 1 through 9 shall apply as modified in Section 10. Surfaces exposed to view of *AESS* members and components shall be fabricated and erected with the care and dimensional tolerances that are stipulated in Sections 10.2 through 10.6.

#### Commentary:

The designation of steel as *AESS* adds cost, and that cost is higher as the level of the *AESS* designation increases. However, not all exposed steel must be designated as *AESS*. There are many applications in which the as-produced appearance of fabricated and erected structural steel may be deemed sufficient without any special additional work.

10.1.1. The following categories shall be used when referring to *AESS*:

**AESS 1:** Basic elements.

**AESS 2:** Feature elements viewed at a distance greater than 20 ft (6 m).

**AESS 3:** Feature elements viewed at a distance less than 20 ft (6 m).

**AESS 4:** Showcase elements with special surface and edge treatment beyond fabrication.

**AESS C:** Custom elements with characteristics described in the *contract documents*.

#### Commentary:

The categories are listed in the *AESS* matrix shown in Table 10.1. Each category describes characteristics with successively more detailed—and costly—requirements.

- Basic elements in AESS 1 are those that have workmanship requirements that exceed what would be done in non-AESS construction.
- Feature elements in AESS 2 and 3 exceed the basic requirements, but the intent is to allow the viewer to see the art of metalworking. AESS 2 is achieved primarily through geometry without finish work, and treats things that can be seen at a larger viewing distance, like enhanced treatment of bolts, welds, *connection* and fabrication details, and tolerances for gaps, copes and similar details. AESS 3 is achieved through geometry and basic finish work, and treats things that can be seen at a closer viewing distance or are subject to touch by the viewer, with welds that are generally smooth but visible. AESS 3 involves the use of a mock-up and acceptance is based upon the approved conditions of the mock-up.
- Showcase elements in AESS 4 are those for which the designer intends that the form is the only feature showing in an element. All welds are ground and filled, edges are ground square and true. All surfaces are filled and sanded to a smoothness that doesn't catch on a cloth or glove. Tolerances of fabricated forms are more stringent—generally half of standard tolerance. AESS 4 involves the use of a mock-up and acceptance is based upon the approved conditions of the mock-up.

- Custom elements in AESS C are those with other requirements defined in the *contract documents*.

10.1.2. A mock-up shall be required for AESS 3, 4 and C. If a mock-up is to be used in other AESS categories, it shall be specified in the *contract documents*. When required, the nature and extent of the mock-up shall be specified in the *contract documents*. Alternatively, when a mock-up is not practical, the first piece of an element or *connection* can be used to determine acceptability.

**Commentary:**

Generally, a mock-up is produced and approved in the shop and subsequently placed in the field. The acceptability of the mock-up can be affected by many factors, including distance of view, lighting and finishing. The expectations for the location and conditions of the mock-up at time of approval should be defined in the *contract documents*.

## 10.2. Contract Documents

The following additional information shall be provided in the *contract documents* when AESS is specified:

- Specific identification of members or components that are AESS using the AESS Categories listed in Section 10.1.2 and Table 10.1.
- Fabrication and/or erection tolerances that are to be more restrictive than provided for in this Appendix, if any.
- For Category AESS C, the AESS matrix included in Table 10.1 shall be used to specify the required treatment of the element.
- Any variations from the AESS characteristics of Table 10.1.
- Any other special requirements for AESS members and components, such as the orientation of HSS weld seams and bolt heads.

## 10.3. Approval Documents

All members designated as AESS shall be clearly identified to a Category, either AESS 1, 2, 3, 4 or C, in the *approval documents*. Tack welds, temporary braces, backing and fixtures used in fabrication of AESS shall be shown in the *fabrication documents*. Architecturally sensitive *connection* details shall be submitted for approval by the *owner's designated representative for design* prior to completion of the *approval documents*.

**Commentary:**

Variations, if any, from the AESS Categories listed must be clearly noted. These variations could include machined surfaces, locally abraded surfaces, and forgings. In addition, if distinction is to be made between different surfaces or parts of members, the transition line/plane must be clearly identified/defined on the *approval documents*.

**TABLE 10.1  
AESS Category Matrix**

Category		AESS C	AESS 4	AESS 3	AESS 2	AESS 1	SSS
Id	Characteristics	Custom Elements	Showcase Elements	Feature Elements in close view	Feature Elements not in close view	Basic Elements	Standard Structural Steel
1.1	Surface preparation to SSPC-SP 6		•	•	•	•	
1.2	Sharp edges ground smooth		•	•	•	•	
1.3	Continuous weld appearance		•	•	•	•	
1.4	Standard structural bolts		•	•	•	•	
1.5	Weld spatters removed		•	•	•	•	
2.1	Visual samples		•	•	optional		
2.2	One-half standard fabrication tolerances		•	•	•		
2.3	Fabrication marks not apparent		•	•	•		
2.4	Welds uniform and smooth		•	•	•		
3.1	Mill marks removed		•	•			
3.2	Butt and plug welds ground smooth and filled		•	•			
3.3	HSS weld seam oriented for reduced visibility		•	•			
3.4	Cross sectional abutting surface aligned		•	•			
3.5	Joint gap tolerances minimized		•	•			
3.6	All welded connections		optional	optional			
4.1	HSS seam not apparent		•				
4.2	Welds contoured and blended		•				
4.3	Surfaces filed and sanded		•				
4.4	Weld show-through minimized		•				
C.1							
C.2							
C.3							
C.4							
C.5							

**User Note:**

- 1.1 Prior to blast cleaning, grease and oil are removed by solvent cleaning to meet SSPC-SP1.
- 1.2 Rough surfaces are deburred and ground smooth. Sharp edges resulting from flame cutting, grinding and especially shearing are softened.
- 1.3 Intermittent welds are made continuous, either with additional welding, caulking or body filler. For corrosive environments, all joints are seal welded. Seams of hollow structural sections are acceptable as produced.
- 1.4 All bolt heads in connections are on the same side, as specified, and consistent from one connection to another.
- 1.5 Weld spatter, slivers, surface discontinuities are removed. Weld projection up to 1/16 in. (2 mm) is acceptable for butt and plug welded joints.
- 2.1 Visual samples are either a 3-D rendering, a physical sample, a first-off inspection, a scaled mock-up or a full-scale mock-up, as specified in the *contract documents*.
- 2.2 These tolerances are one-half of those for standard structural steel as specified in this Code.
- 2.3 Members markings during the fabrication and erection processes are not visible.
- 3.1 All mill marks are not visible in the finished product.
- 3.2 Caulking or body filler is acceptable.
- 3.3 Seams are oriented away from view or as indicated in the *contract documents*.
- 3.4 The matching of abutting cross sections is required.
- 3.5 This characteristic is similar to 2.2 above. A clear distance between abutting members of 1/8 in. (3 mm) is required.
- 3.6 Hidden bolts may be considered.
- 4.1 HSS seams are treated so they are not apparent.
- 4.2 In addition to a contoured and blended appearance, welded transitions between members also are contoured and blended.
- 4.3 The steel surface imperfections are filled and sanded.
- 4.4 Weld show-through on the back side of a welded element can be minimized by hand grinding the back side surface. The degree of weld-through is a function of weld size and material.
- C. Additional characteristics may be added for custom elements.

## 10.4. Fabrication

10.4.1. The *fabricator* shall handle the steel with care to avoid marking or distorting the steel members:

- (a) Slings shall be nylon-type or chains or wire rope with softeners.
- (b) Care shall be taken to minimize damage to any shop paint or coating.
- (c) When temporary braces or fixtures are required during fabrication or shipment, or to facilitate erection, care shall be taken to avoid blemishes or unsightly surfaces resulting from the use or removal of such temporary elements.
- (d) Tack welds not incorporated into final welds shall be treated consistently with requirements for final welds.
- (e) All backing and runoff tabs shall be removed and the welds ground smooth.
- (f) All bolt heads in *connections* shall be on the same side, as specified, and consistent from one *connection* to another.

10.4.2. Members fabricated of unfinished, reused, galvanized or weathering steel that are to be *AESS* may still have erection marks, painted marks or other marks on surfaces in the completed structure. Special requirements, if any, shall be specified as Category *AESS C*.

10.4.3. The permissible tolerances for member depth, width, out of square, and camber and sweep shall be as specified in ASTM A6/A6M and ASTM A500/A500M. The following exceptions apply:

- (a) For Categories *AESS 3* and *4*, the matching of abutting cross sections shall be required.
- (b) For Categories *AESS 2*, *3* and *4*, the as-fabricated straightness tolerance shall be one-half of that specified in ASTM A6/A6M and ASTM A500/A500M.

10.4.4. For curved structural members, whether composed of a single *standard structural shape* or built-up, the as-fabricated variation from the theoretical curvature shall be equal to or less than the standard camber and sweep tolerances permitted for straight members in the applicable ASTM standard.

### Commentary:

The curvature tolerance for curved *AESS* members is not reduced from that used for curved non-*AESS* members because curved members have no straight line to sight and the resulting deviations are therefore indistinguishable. See also the Commentary to Section 6.4.2.

10.4.5. The tolerance on overall profile dimensions of welded built-up members shall meet the requirements in AWS D1.1/D1.1M. For Categories *AESS 2*, *3* and *4*, the as-fabricated straightness tolerance for the member as a whole shall be one-half of that specified in AWS D1.1/D1.1M.

10.4.6. For Categories *AESS 3* and *4*, copes, miters and cuts in surfaces exposed to view shall have a gap that is uniform within  $\frac{1}{8}$  in. (3 mm), if shown to be an open joint. If instead the joint is shown to be in contact, the contact shall be uniform within  $\frac{1}{16}$  in. (2 mm).



- 10.4.7. For Categories AESS 1, 2 and 3, the surface condition of steel given in ASTM A6/A6M shall be acceptable. For Category AESS 4, surface imperfections shall be filled and sanded to meet the acceptance criteria established with the mock-up required in Section 10.1.2.
- 10.4.8. For Categories AESS 1, 2 and 3, welds shall meet AWS D1.1/D1.1M requirements, except that weld spatter exposed to view, if any, shall be removed. For Category AESS 4, welds shall be contoured and blended, and spatter exposed to view, if any, shall be removed.
- 10.4.9. For Categories AESS 1 and 2, weld projection up to  $1/16$  in. (2 mm) is acceptable for butt and plug welded joints. For Categories AESS 3 and 4, welds shall be ground smooth/filled.
- 10.4.10. For Categories AESS 1, 2 and 3, *weld show-through* shall be acceptable as produced. For Category AESS 4, the *fabricator* shall minimize the *weld show-through*.

**Commentary:**

*Weld show-through* is a visual indication of the presence of a weld or welds on the opposite surface from the viewer. It is a function of weld size and material thickness and can't be eliminated in thin material with thick welds. When *weld show-through* is a concern, this should be addressed in the mock-up.

- 10.4.11. AESS shall be prepared to meet the requirement of SSPC-SP 6. Prior to blast cleaning:
- Grease or oil, if any is present, shall be removed by solvent cleaning to meet the requirements of SSPC-SP 1.
  - Weld spatter, slivers and similar surface discontinuities shall be removed.
  - Sharp corners resulting from shearing, flame cutting or grinding shall be eased.
- 10.4.12. For Categories AESS 1 and 2, seams of hollow structural sections shall be acceptable as produced. For Category AESS 3, seams shall be oriented as specified in the *contract documents*. For Category AESS 4, seams shall be treated so they are not apparent.

**10.5. Delivery of Materials**

The *fabricator* shall use special care to avoid bending, twisting or otherwise distorting AESS. All tie-downs on loads shall be nylon straps or chains with softeners to avoid damage to edges and surfaces of members. The standard for acceptance of delivered and erected members shall be equivalent to the standard employed at fabrication.

**10.6. Erection**

The *erector* shall use special care in unloading, handling and erecting AESS to avoid marking or distorting the AESS. The *erector* shall plan and execute all

operations in such a manner that allows the architectural appearance of the structure to be maintained:

- (a) Slings shall be nylon-type or chains or wire rope with softeners.
- (b) Care shall be taken to minimize damage to any shop paint or coating.
- (c) When temporary braces or fixtures are required to facilitate erection, care shall be taken to avoid any blemishes, holes or unsightly surfaces resulting from the use or removal of such temporary elements.
- (d) Tack welds not incorporated into final welds shall be ground smooth.
- (e) All backing and runoff tabs shall be removed and the welds ground smooth.
- (f) All bolt heads in *connections* shall be on the same side, as specified, and consistent from one *connection* to another.
- (g) For Category AESS 4, open holes shall be filled with weld metal or body filler and smoothed by grinding or filling to the standards applicable to the shop fabrication of the materials.