

**2015 CITY OF WINNIPEG**  
ACCESSIBILITY DESIGN STANDARD  
THIRD EDITION

REVISED SEPTEMBER 2018

## ACKNOWLEDGEMENTS

# ACKNOWLEDGEMENTS

November 2015

Re: the revised 2015 City of Winnipeg Accessibility Design Standards



Dear Reader/user of these Standards

On behalf of the City of Winnipeg Universal Design office, we are pleased to present the 2015 revised City of Winnipeg Accessibility Design Standard. The design standards presented in this manual are intended to apply to all newly constructed and/or renovated facilities in accordance with the application and enforcements chapters. We would like to thank the following contributors and reviewers of this document:

- Members of the City of Winnipeg staff Technical Review Committee
- The Coordinator and Members of the Access Advisory Committee
- Nadia Selby – Technician with Parks Planning
- Rebecca Van Beveren – Planning: Information Systems



## Reference Documents:

Designable Environments – original developer of the Accessibility Design Standard 2006

City of Winnipeg Standard Construction Specifications

Children's Play Spaces and Equipment - CAN/CSA Z614

2001 Facility Accessibility Design Standards for the City of London

City of Winnipeg Parks and Open Space Specifications

NRC - National Building Code of Canada – 2010

Barrier Free Design CAN/CSA – B651/12

The City of Winnipeg Zoning By-Law 200/06

Province of Manitoba Office of the Fire Commissioner Building Code Amendments 2011 (MR 118/2014)

Metric Handbook Planning and Design Data, Second Edition

Province of Manitoba Highway Traffic Act

City of Mississauga Accessibility Design Handbook, 2nd Edition 2007

Illuminating Engineering Society of North America Standards

In addition to our use of this manual for our own facilities, we encourage the use of the 2015 City of Winnipeg Accessibility Design Standard throughout the community and hope that you find them interesting and valuable for your facility construction and/or renovation projects.

Judy Redmond, MSc.. Accessibility and Inclusive Design  
Universal Design Coordinator  
City of Winnipeg

On Page 163, Section 3.3.7, regarding the height of an adult change bench, please note this information was revised in September 2018.

# TABLE OF CONTENTS

<b>Introduction</b> .....	7
<b>Definitions</b> .....	15
<b>Scope and Application</b> .....	23

## **Design Standards**

<b>1.0 General Design Standards</b> .....	27
---	----

### **1.1 General Access and Circulation**

1.1.1 Space and Reach Requirements .....	28
1.1.2 Protruding and Overhead Objects .....	32
1.1.3 Accessible Routes, Paths and Corridors .....	34
1.1.3.1 Private Development Requirements for Pedestrian Routes.....	38
1.1.4 Gates, Turnstiles and Openings .....	40
1.1.5 Ramps .....	42
1.1.6 Stairs .....	46
1.1.7 Handrails and Guards .....	48
.....1.1.8 Accessible Routes: Maintenance.....	50

### **1.2 General Information and Communication Systems**

1.2.1 Texture, Finishes and Colour .....	51
1.2.2 Acoustics .....	53
1.2.3 Public Address Systems .....	54
1.2.4 Signage .....	55
1.2.5 Information Systems .....	58
1.2.6 Detectable Warning Systems .....	60

### **1.3 General Amenities**

1.3.1 Drinking Fountains & Bottle Fillers.....	62
1.3.2 Vending and Ticketing Machines .....	64
1.3.3 Elevated Areas and Platforms .....	66
1.3.4 Waiting and Queuing Areas .....	68
1.3.5 Seating .....	69

### **1.4 General Context Specific Requirements**

1.4.1 Water Features .....	72
1.4.2 Public Historic Places .....	74
1.4.3 Fixed Seating Assembly Facilities .....	75

# TABLE OF CONTENTS

<b>2.0 Exterior Design Standards</b> .....	79	3.2.5 Storage, Shelving and Display Units .....	146
<b>2.1 Exterior Access and Circulation</b>		3.2.6 Universal Change Rooms .....	147
2.1.1 Exterior Ground Surfaces .....	80	3.2.7 Lockers and Storage Units .....	149
2.1.2 Exterior Lighting .....	83	<b>3.3 Washroom Facilities</b>	
2.1.3 Streetscape .....	84	3.3.1 Toilet Facilities .....	150
2.1.4 Traffic Signal Poles .....	87	3.3.2 Toilet Stalls .....	152
2.1.5 Curb Ramps and Truncated Dome Detectable Warning Surfaces .....	89	3.3.3 Toilets .....	154
<b>2.2 Exterior Amenities</b>		3.3.4 Lavatories .....	156
2.2.1 Balconies, Plazas and Patios .....	91	3.3.5 Urinals .....	158
2.2.2 Plantings .....	94	3.3.6 Washroom Accessories .....	160
2.2.3 Picnic Tables .....	95	3.3.7 Universal Toilet Rooms.....	162
2.2.4 Dog Relief Areas .....	97	3.3.8 Grab Bars .....	165
<b>2.3 Exterior Context Specific Requirements</b>		3.3.9 Shower Stalls .....	166
2.3.1 Parking .....	98	<b>3.4 Interior Information and Communication Systems</b>	
2.3.2 Passenger Loading Zones .....	102	3.4.1 Visual Alarms .....	168
2.3.3 Outdoor Recreational Facilities .....	104	3.4.2 Assistive Listening Systems .....	169
2.3.4 Transit Facilities .....	108	<b>3.5 Interior Systems and Controls</b>	
2.3.5 Play Areas .....	111	3.5.1 Controls and Operating Mechanisms .....	170
<b>3.0 Interior Design Standards</b> .....	113	3.5.2 Card Access, Safety and Security Systems .....	172
<b>3.1 Interior Access and Circulation</b>		3.5.3 Interior Lighting .....	173
3.1.1 Interior Floor Surfaces .....	114	3.5.4 Interior Glare and Light Sources .....	174
3.1.2 Entrances .....	116	<b>3.6 Interior Context Specific Requirements</b>	
3.1.3 Doors .....	118	3.6.1 Arenas, Gymnasiums, Halls and Other Indoor Recreational Facilities .....	175
3.1.4 Windows, Glazed Screen and Sidelights .....	125	3.6.2 Cafeterias .....	176
3.1.5 Elevators .....	127	3.6.3 Libraries .....	178
3.1.6 Platform Lifts .....	131	3.6.4 Cashiers and Workplace Accommodations .....	181
3.1.7 Escalators .....	133	3.6.5 Emergency Services .....	182
3.1.8 Emergency Exits, Fire Evacuation and Areas of Rescue and Assistance .....	134	3.6.6 Public Housing .....	184
<b>3.2 Interior Amenities</b>		3.6.7 Training Facilities .....	185
3.2.1 Information, Reception and Service Counters .....	136	<b>Appendix A Universal Design Principles</b> .....	189
3.2.2 Tables, Counters and Work Surfaces .....	138	<b>Appendix B Change Order Form</b> .....	193
3.2.3 Offices, Work Areas and Meeting Rooms .....	140	<b>Index</b> .....	197
3.2.4 Kitchens and Kitchenettes .....	141		

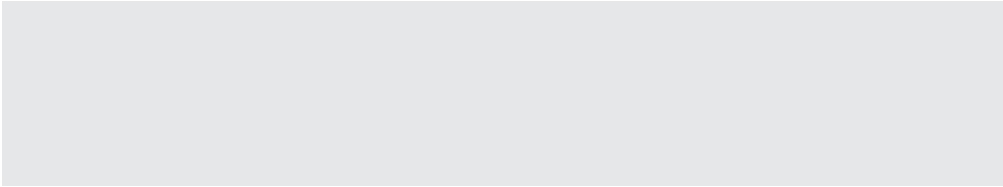

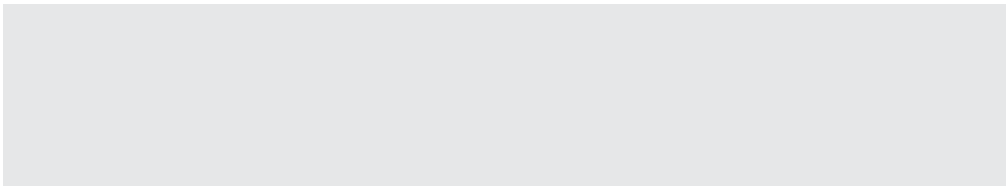

# INTRODUCTION

# INTRODUCTION

## INTRODUCTION

### Mandate:

The City of Winnipeg is committed to *barrier* prevention and removal and inclusion through its [Universal Design Policy](#) adopted by City Council in 2001. In doing so, Winnipeg has embraced the principles of “universal design” (Mace, University of North Carolina, 1997, see page 190). An Administrative Standard has been established to direct every civic employee to adhere to the Universal Design policy. As City employees we are all responsible to:

- Respect human diversity
- Promote inclusion of all people in all activities of life to the greatest extent possible
- Create environments, programs and services that respond to the needs of the widest range of the population possible including a diversity of body types, identities and abilities.

This standard clarifies the lines of authority and outlines roles and responsibilities for key decision makers throughout the organization. As a supporting document to the policy, the Accessibility Design Standard provides requirements for the built environment in the areas of:

- General Design Features
- Exterior Design Features
- Interior Design Features

## REGULATORY FRAMEWORK

This standard is intended to support the implementation of regulations which includes the following:

### Federal:

- The United Nations Universal Declaration of Human Rights and Convention on the Rights of Persons with Disabilities signed and ratified by Canada on December 3, 2012 defines:

#### Article 9 - Accessibility

1. To enable persons with disabilities to live independently and participate fully in all aspects of life, States Parties shall take appropriate measures to ensure to persons with disabilities access, on an equal basis with others, to the physical environment, to transportation, to information and communications, including information and communications technologies and systems, and to other facilities and services open or provided to the public, both in urban and in rural areas. These measures, which shall include the identification and elimination of obstacles and *barriers* to accessibility, shall apply to, inter alia:
  - a. Buildings, roads, transportation and other indoor and outdoor facilities...including workplaces;
  - b. Information, communications and other services, including electronic services and emergency services.
2. States Parties shall also take appropriate measures to:
  - a. Develop, promulgate and monitor the implementation of minimum standards and guidelines for the accessibil-

ity of facilities and services open or provided to the public;

- b. Ensure that private entities that offer facilities and services which are open or provided to the public take into account all aspects of accessibility for persons with disabilities;
  - c. Provide training for stakeholders on accessibility issues facing persons with disabilities;
  - d. Provide in buildings and other facilities open to the public signage in Braille and in easy to read and understand forms;
  - e. Provide forms of live assistance and intermediaries, including guides, readers and professional sign language interpreters, to facilitate accessibility to buildings and other facilities open to the public;
  - f. Promote other appropriate forms of assistance and support to persons with disabilities to ensure their access to information;
  - g. Promote access for persons with disabilities to new information and communications technologies and systems, including the Internet;
  - h. Promote the design, development, production and distribution of accessible information and communications technologies and systems at an early stage, so that these technologies and systems become accessible at minimum cost.
- NRC - National Building Code requirements must be met



## Provincial:

1. Manitoba Human Rights Code: Discrimination under The Code is treating a person or group differently, to their disadvantage and without reasonable cause, on the basis of a protected characteristic, such as ancestry, age, disability, sex, gender identity or sexual orientation. <http://www.manitobahuman-rights.ca/>
2. Accessibility for Manitobans Act (December 2013): This Act enables the establishment of accessibility standards to achieve accessibility for Manitobans disabled by *barriers*. A person or organization that is subject to an accessibility standard will be required to take actions to identify and remove *barriers* and to prevent new *barriers* from being created. This Act requires the government, municipalities and prescribed public sector organizations to prepare annual accessibility plans and make them publicly available
3. Manitoba Building Code and Amendments: Provisions for minimum *barrier* free design under part 3.8 of Manitoba Building Code [http://www.firecomm.gov.mb.ca/codes\\_acts\\_amendments.html](http://www.firecomm.gov.mb.ca/codes_acts_amendments.html)

## Municipal:

1. “Our Winnipeg” July 2011: The City of Winnipeg’s municipal development plan was adopted by Council

July 2011. This is the Cities highest level planning policy document. This Policy establishes four direction strategies in order for Winnipeg citizens to prosper and have a high quality of life. These strategies are Complete Communities, Sustainable Transportation, Sustainable Winnipeg and Sustainable Water and Waste. The principles of universal design are particularly embedded within the next two described strategies.

- a. Complete Communities
  - The first principle of creating a complete community and completing existing communities to ensure they are attractive and competitive is to enhance existing infrastructure and assets in ways that make most amenities for daily living universally accessible
  - Creating complete communities and completing existing communities – enhancing their existing infrastructure and assets in ways that make most amenities for daily living universally accessible will be key to making our city attractive and competitive.
- b. Sustainable Transportations and the Transportation Master Plan (TMP)
  - Building on the Sustainable Transportation Direction Strategy, the TMP places significant emphasis on providing transportation choice. In doing

so, it commits to ensuring that transportation projects, programs and initiatives reflect accessibility and universal design principles, and identifies a number of enabling strategies to achieve this

2. City of Winnipeg Standard Construction Specifications: Winnipeg’s expectations and requirements for construction of road public rights of way and parkland
3. City of Winnipeg Zoning By-Law & Downtown Winnipeg Zoning By-law
  - a. 2014 requirement for accessible vehicle parking numbers, size and space
  - b. 2014 requirement for accessible routes from the public sidewalk to the main entrance of a building
4. City of Winnipeg Universal Design Policy (December 2001): The City of Winnipeg will ensure all new construction, major renovations to buildings and exterior environments as well as purchases and new developments in services, products, information, communication or other systems that are funded in whole or in part by the City of Winnipeg will follow Universal Design criteria. City employees are directed to review projects as part of the budget process, and while contracting and during the tendering processes.

# INTRODUCTION

Equal access through the removal of *barriers* makes good business sense. Recent research has shown that fifty three percent of families are affected by disability (Donovan, 2012). People with disabilities and their families are becoming the majority in Canada. This percentage translates to approximately nine million people and \$250,000.00 billion in disposable income. People affected by disabling conditions is expected to grow as we age.

A 2011 report by the National Center for Transgender Equality and National Gay and Lesbian Task Force reports 53% experience *barriers* in places of public accommodation. The City of Winnipeg is committed to meeting the challenges of *barrier* removal by being the best accessible City it can be.

## INTENT:

The Accessibility Design Standard is intended to support the implementation of the City's Universal Design Policy within built environments. It has been created to be:

- a best practice, minimum standard necessary to further the implementation of the Universal Design Policy
- attentive to a diverse range of user needs from infancy to older age including all body types, abilities, sex, gender identity, sexual orientation, race and socio economic backgrounds
- inspirational to design professionals to be innovative and creative in design ideas and

solutions

- a broad and flexible tool to be used in applying the principles of universal design
- based on an inclusive approach whereby public engagement and a "nothing about me without me" methodology is utilized
- cognizant of a multitude of factors that need to be considered and addressed when incorporating the principles of universal design. Circumstances may vary project to project; therefore the need to consult using an integrated planning approach to identify *barriers* at the onset of a project is imperative

## ADMINISTRATION AND GENERAL APPLICATION:

### Application of the Accessibility Design Standard

The purpose of this standard is to provide accessibility requirements to City of Winnipeg employees, project managers and consultants in the implementation of the Universal Design Policy for the built environment. This standard is meant to be applied to both public and employee spaces within city funded, owned, leased or occupied spaces.

The requirements of this design standard are mandatory for:

- All new construction of City buildings and exterior environments including additions that are funded in whole or in part by the City of Winnipeg (i.e., 1199 Pacific)
- All major renovations of City

buildings and exterior environments that are funded in whole or in part by the City of Winnipeg (Note: an alteration may or may not require further MBC upgrades)

- All altered portions of existing facilities shall comply with this standard, unless otherwise specified in Sections 1.4 General Context Specific Requirements, 2.3 Exterior Context Requirements and 3.6 Interior Context Specific Requirement
- All single elements, if alterations of these single elements, when considered together, amount to an alteration of a room or space in a facility, the entire space shall comply with this standard

This design standard is also mandatory for:

- All facilities considered for public use funded by the City of Winnipeg through funding agreements (i.e. Convention Centre)
- All private facilities funded through funding agreements or grants over \$50,000.00 (i.e. Daycares)
- All spaces not owned, but occupied by the City of Winnipeg (i.e. Fort Garry Place)
- All spaces owned but not occupied by the City of Winnipeg (3rd party) (i.e. Seniors Centres)
- All public private partnerships (P3's) (i.e. Disraeli Bridge)
- All temporary facilities as well as permanent facilities (i.e. Temporary Location of the

Winnipeg Archives)

**IMPORTANT NOTE:**

- No alteration shall have the effect of decreasing accessibility or usability of an existing facility to below the requirements for new construction at the time of alteration. If existing elements, spaces or common areas are altered, then each such altered element/ space/ feature/ area shall comply with all applicable provisions.

The design requirements of this manual do not apply to:

- Service rooms, elevator machine rooms, janitor rooms, service spaces, crawl spaces, and attics or roof spaces;
- Buildings of Group F Division 1 occupancy, as defined by the MBC; and
- Buildings which are not intended to be occupied as a place of daily or full-time activity including but not limited to automatic telephone exchanges, pump houses, sewage treatment and water treatment facilities and substations
- Privately owned single family or boarding residential receiving city grants (Part 9 of MBC)

**HOW AND WHEN TO USE THE STANDARD IN THE PROJECT DESIGN PROCESS**

In accordance with the City of Winnipeg Administrative Standard, this Accessibility Design Standard must be incorporated throughout all stages of project planning, development and

implementation:

Step 1: Review this standard when scoping a project to ensure sufficient budget is in place to apply the standard as the project moves forward to the design stage

Step 2: Incorporate this standard into the design stage

- It is imperative to understand who will be using the facility in order to meet their needs. Consider a diverse range of user needs based on an inclusive approach to public engagement. Where possible, end users shall be consulted early in project development

Step 3: Develop design program and functional requirements using the standard

- Develop conceptual, 33%, 66% 99% and final designs using the Accessibility Design Standard document and lens

Step 4: Design Review

- utilize designated departmental expertise in universal design for compliance with the Accessibility Design Standard

Step 5: Post occupancy evaluation

- Ground truth that the Accessibility standards have been achieved

NOTE: Where conflicts exist between scoping and/or dimensional requirements of this standard and standards or legislation enacted by the federal or provincial governments, the most accommodating requirement shall apply. Dimensions shall never fall less than the minimum requirements of the Manitoba

Building Code (MBC).

**ENFORCEMENT RESPONSIBILITIES**

The Universal Design Policy directs the City of Winnipeg to institute a Universal Design Review process. This process requires each department (division) to designate a staff that is responsible to review for compliance with the Accessibility Design Standard and the Universal Design Policy. That person must have completed the Universal Design training course provided yearly by Corporate Education Branch.

This standard is not intended to prevent the use of other designs, products or technologies as alternatives to those identified. This assumes that these alternatives will result in an equivalent or increased level of accessibility. Under the Accessibility for Manitobans Act, the Province requires a reporting process of notation for each implementation alternative variance for a *Barrier Removal Plan* (see below). Equivalent facilitation or a variance from the Accessibility Design Standard must be proposed, assessed, and a written explanation of how the intent of the ADS was met. This variance document will be sent to the Universal Design office for vetting on an individual basis.

**BARRIER REMOVAL PLAN**

The City of Winnipeg is required under the Accessibility for Manitobans Act, to establish a *barrier removal plan* every two years. This plan will establish a list of

# INTRODUCTION

priorities where current *barriers* will be mitigated.

Each departmental designate will be responsible to provide a bi-yearly plan to include what their department has done to:

1. Identify *barriers*
2. Prevent *barriers*
3. Remove *barriers*
4. Consult with people with disabilities

This plan will be submitted to the Universal Design office and will be posted and available to the public.

## REVIEW AND UPDATING THE ACCESSIBILITY DESIGN STANDARD

The City of Winnipeg shall review and/or update this design standard at least every 5 years, or as deemed necessary to reflect well researched user feedback, technological advancements and new

construction practices, as well as approved changes to the *barrier-free* requirements of various codes and standards (Accessibility for Manitobans Act, MBC and CSA B651)

## DEFINITION OF UNIVERSAL DESIGN

Universal Design is defined as “the design of products and environments to be usable by all people, to the greatest extent possible, without the need for adaptation or specialized design” (Mace, R., 1983). The universal design philosophy as established by Mace is structured around the seven principles listed below

## HUMAN FACTORS

The Accessibility Design Standard reflects minimum dimensional criteria required for adult persons. This standard covers a variety of human factors and a

range of needs within each category. Examples are as follows:

- Sensory (Touch, Smell, low hearing, Deafness, low vision and blindness)
- Intellectual (developmental, brain injury, literacy or learning, age related dementia)
- Physical (mobility, agility)
- Mental health (various)
- Communication
- Gender identity and expression

## MEASUREMENTS

Dimensions used in this manual are in metric units. The nearest imperial equivalent dimensions are in parenthesis.

Anthropometric data collected and tested by the University of Buffalo and the State University of New York IDEA Center (December 2010) was considered in the development of the size requirements for this standard.

### 1. **EQUITABLE USE:**

The design is useful and marketable to people with diverse abilities.

### 2. **FLEXIBILITY IN USE:**

The design accommodates a wide range of individual preferences and abilities.

### 3. **SIMPLE AND INTUITIVE USE**

Use of the design is easy to understand, regardless of the user’s experience, knowledge, language skills, or current concentration level.

### 4. **PERCEPTIBLE INFORMATION:**

The design communicates necessary information effectively to the user, regardless of ambient conditions or the user’s sensory abilities.

### 5. **TOLERANCE FOR ERROR:**

The design minimizes hazards and the adverse consequences of accidental or unintended actions.

### 6. **LOW PHYSICAL EFFORT:**

The design can be used efficiently and comfortably with a minimum of fatigue.

### 7. **SIZE AND SPACE FOR APPROACH AND USE:**

Appropriate size and space are provided for approach, reach, manipulation and use, regardless of user’s body position, size, posture or mobility.

## Seven Design Principles



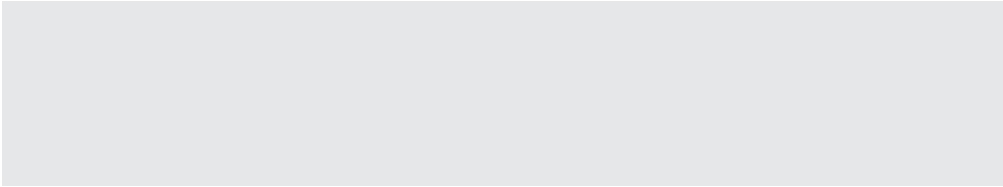

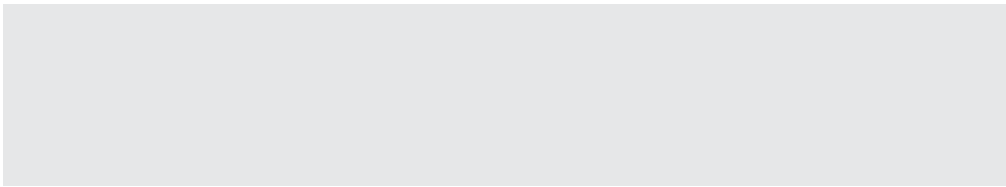

## **DEFINITIONS**

# DEFINITIONS

## GRAPHIC CONVENTIONS

All measurements are in metric followed by the imperial equivalent.

Dimensions that are not marked maximum or minimum are absolute, unless otherwise indicated.

Please note: the drawings in this document examples only and are not to scale.

## GENERAL TERMINOLOGY

### **comply with**

Meet one or more specifications of this manual.

### **if ... then**

Denotes a specification that applies only when the conditions described are present.

### **may**

Denotes an option or alternative.

### **shall**

Denotes a mandatory specification or requirement.

### **should**

Denotes an advisory specification or recommendation.



## DEFINITIONS

**Access Aisle:**

An *accessible* pedestrian *space* between *elements*, such as parking *spaces*, seating and desks, that provides clearances appropriate for the use of the *elements*.

**Accessible:**

Describes a *site*, *building*, *facility*, *public right-of-way* or portion thereof that complies with the requirements of this design standard.

**Accessible Element:**

An *element* specified by this manual (for example, telephone, controls etc.).

**Accessible Route:**

A clear path of travel which is unobstructed by vertical, visually busy horizontal patterns and/or overhanging elements. It is continuous and connects *accessible elements* and *spaces* of a *facility*. Interior *accessible routes* may include corridors, floors, *ramps*, elevators, platform lifts and *clear spaces* at fixtures. Exterior *accessible routes* may include parking *access aisles*, *curb ramps*, crosswalks at *vehicular ways*, *walks*, *ramps* and platform lifts.

**Accessible Space:**

*Space* that complies with the requirements of this design standard.

**Active Transportation Routes:**

Any transportation route intended to be used by human-powered

modes of transportation such as cycling, walking, skiing, and skateboarding. The main emphasis is on travel for a specific purpose or to a specific location. However, this definition does not exclude travel for purely recreational purposes.

**Adaptable:**

The ability of a certain *building space* or *element*, such as kitchen counters, sinks, and grab bars, to be added or altered so as to accommodate the needs of individuals with or without *disabilities* or to accommodate the needs of persons with different types or degrees of *disabilities*.

**Addition:**

An expansion, extension, or increase in the gross floor area of a *facility*.

**Alteration:**

A change to a *facility*, including a change of use, that affects or could affect the usability of the *facility* or part thereof. *Alterations* include, but are not limited to, remodelling, renovation, *retrofitting*, rehabilitation, reconstruction, historic restoration, resurfacing of *circulation paths* or *vehicular ways*, changes or rearrangement of the structural parts or *elements*, and changes or rearrangement in the plan configuration of walls and full-height partitions. Normal maintenance, painting or wallpapering, or changes to mechanical or electrical systems are not *alterations*, unless they affect the usability of the *building*.

**Area of Rescue Assistance:**

An area which has direct access to an exit, where people who are unable to use stairs may remain temporarily in safety to await further instructions or assistance during emergency evacuation.

**Assembly Area:**

A room or *space* accommodating a group of individuals for recreational, educational, political, social, civic or amusement purposes, or for the consumption of food and drink.

**Assistive Listening Device:**

Equipment used to receive sound output from the *Assistive Listening System*.

**Assistive Listening Systems:**

Wireless sound transmission systems that improve sound reception for persons with hearing disabilities by providing amplification which can be adjusted by each user while blocking out unwanted background noise.

**Attic Space:**

The unoccupied *space* between the roof and the ceiling of the top *storey* or between a dwarf wall and a sloping roof.

**Automatic Door:**

A door equipped with a power-operated mechanism and controls that open and close the door automatically upon receipt of a momentary actuating signal. The switch that begins the automatic cycle may be a photoelectric device, floor mat, or manual switch. (See *Power-Assisted Door*).

## DEFINITIONS

### **Barrier**

Something that impedes people or separates them, either material or immaterial. It can be a circumstance or obstacle that limits access and/or prevents communication and/or progress in order to achieve an objective.

### **Building**

Any structure used or intended for supporting or sheltering any use or occupancy.

### **Cane-Detectable**

Within the detection range of a cane as it sweeps or taps.

### **Circulation Path**

An exterior or interior way of passage from one place to another for pedestrians, including, *walks*, hallways, courtyards, stairways, and stair landings.

### **Clear Space**

The minimum unobstructed floor or ground *space* required to accommodate a single, stationary wheelchair, scooter or other mobility device, including the user.

### **Closed-Circuit Telephone**

A telephone with dedicated line (s), such as a house phone, courtesy phone or phone that must be used to gain *entrance* to a *facility*.

### **Colour Contrast**

A significant contrast in colour between the foreground and background of an *element*, e.g., light on a dark background or dark on light background.

An eggshell finish (11 to 19

degree gloss on 60 degree glossimeter) is recommended. Research indicates that signs are more legible for persons with low vision when characters contrast with their background by at least 70%. Contrast in percent shall be determined by:

$$\text{Contrast} = [(B_1 - B_2) / B_1] \times 100$$

where  $B_1$  = light reflectance value (LRV) of the lighter area and  $B_2$  = light reflectance value (LRV) of the darker area.

Note that in any application both white and black are never absolute; thus,  $B_1$  never equals 100 and  $B_2$  is always greater than 0.

The greatest readability is usually achieved through the use of light-coloured characters or symbols on a dark background.

### **Common Use**

Refers to those interior and exterior rooms, *spaces* or *elements* that are made available for use by groups of people (for example, occupants of a homeless shelter, the occupants of an office *building* (including employees), or the guests of such occupants).

### **Conspicuity**

The property of being clearly discernible  
The state or quality of being clear or bright; brightness; conspicuousness.

### **Cross Slope**

The slope that is perpendicular to the direction of travel. (See *ramp slope*)

### **Curb Ramp**

The combined curb taper and depressed curb (see sidewalk ramp for further definition).

### **Detectable Warning**

A standardized surface feature built into or applied to walking surfaces or other *elements* to warn persons with vision *impairments* of hazards on a *circulation path*.

### **Disability**

A circumstantial limitation occurring when a person's physical, social and/or institutional environment fails to accommodate their functional needs. The experience of disability can be minimized by designing environments to accommodate a range of physical and sensory capabilities.

### **Egress. Means of**

A continuous and unobstructed way of exit travel from any point in a *facility* to a *public right-of-way*. A *means of egress* comprises vertical and horizontal travel and may include intervening room *spaces*, doorways, hallways, corridors, passageways, balconies, *ramps*, stairs, enclosures, lobbies, horizontal exits, courts and yards.

An *accessible means of egress* is one that complies with the design requirements of this manual and does not include stairs, steps or escalators. Areas of rescue assistance, protected lobbies or protected elevators may be included as part of an *accessible means of egress*.

**Element:**

An architectural or mechanical component of a *building*, *facility*, *space* or *site* (e.g., telephone, *curb ramp*, door, drinking fountain, seating or water closet).

**Entrance:**

Any access point into a *building* or a *facility* used for the purposes of entering. An *entrance* includes the approach *walk*, the vertical access leading to the *entrance* platform, the *entrance* platform itself, vestibules (if provided), the entry door(s) or gate(s), and the hardware of the entry door(s) or gate(s).

**Facility or Facilities:**

All or any portion of *buildings*, structures, *site improvements*, complexes, equipment, roads, *walks*, passageways, *parks*, parking lots or other real or personal property located on a *site*, or within a *public right-of-way*.

**Ground Floor:**

Any *occupiable* floor less than one *storey* above or below grade with direct access to grade. A *facility* always has at least one *ground floor* and may have more than one *ground floor*, as where a split-level *entrance* has been provided or where a *facility* is built into a hillside.

**Guard:**

A safety railing used as a *barrier* to prevent encroachment or accidental falling from heights.

**Handrail:**

A component which is normally grasped by hand for support at stairways and other places where needed for safety of pedestrians

**Impairment:**

Any loss or abnormality of psychological, physiological or anatomical structure or function.

**Indicator Surface:**

A ground surface that is in *colour contrast* to an adjacent *accessible route*, as well as textured differently to the surface of the *accessible route* to be *cane-detectable*.

**Light Reflectance Value (LRV):**

*LRV* is a measure of the percentage[1] of visible and usable light that is reflected from a surface when illuminated by a light source.

**MBC:**

*MBC* is the abbreviation for the latest edition of the Manitoba Building Code with all amendments.

**Meeting Room:**

Room used for meetings, which accommodates more than six people.

**Mezzanine or Mezzanine Floor:**

An intermediate floor assembly between the floor and ceiling of any room or *storey* and includes an interior balcony.

**Multi-Use Pathway:**

A *multi-use pathway* is physically separated from motor vehicle traffic and can be either within the highway *right-of-way* or within an independent *right-of-way*. *Multi-use pathways* include bicycle paths, rail-trails or other facilities built for bicycle and pedestrian traffic.

**Occupiable:**

A room or enclosed *space*

designed for any human occupancy in which individuals congregate for amusement, educational or similar purposes, or in which occupants are engaged at labour, and which is equipped with *means of egress*, light and ventilation.

**Open Space:**

Large-scale tracts of land without visible evidence of residential, commercial or industrial development. These areas may be privately or publicly owned and are generally left in a natural state and not programmed for active recreation. The benefits of open lands typically extend beyond the immediate area and usually provide community-wide benefits.

**Operable Portion:**

A part of a piece of equipment or appliance used to insert or withdraw objects, or to activate, deactivate, or adjust the equipment or appliance (for example, coin slot, push button, handle).

**Park:**

Land that is privately or publicly held that has been developed for multiple recreational and leisure-time uses. This land benefits the entire community and balances the demands of the public for outdoor recreational *facilities* and other amenities, such as pathways, plazas, picnic areas, playgrounds, water features, *spaces* for free play and leisure.

**Power-Assisted Door:**

A door used for human passage that has a mechanism that helps to open the door or relieves the opening resistance of a door,

## DEFINITIONS

upon the activation of a switch or a continued force applied to the door itself.

### **Public Historic Place:**

A publicly accessible structure, *building*, group of *buildings*, district, landscape, archaeological *site* or other place in Winnipeg that has been formally recognized by the City for its heritage value and/or identified on the Building Conservation List within the City of Winnipeg.

### **Public Right-of-Way:**

A portion of public land reserved or used for a *street*, lane, walkway, *active transportation route*, park, public plaza, green space, drainage facility, natural area or other public purpose. (*Public right-of-way* does not apply to private property).

### **Public Use:**

Describes interior or exterior rooms, *spaces* or amenities that are made available to the general public. *Public use* may be provided at a *facility* that is privately or publicly owned.

### **Ramp:**

A walking surface which has a *ramp slope* greater than 1:20 (5%) that is not a sidewalk slope at a curb ramp.

### **Ramp slope:**

The slope of a *ramp* that is parallel to the direction of travel. (See *Cross Slope*).

### **Retrofit:**

See *Alteration*.

### **Roof Space:**

Attic area, or area between a dwarf partition and sloping roof.

### **Service Entrance:**

An *entrance* intended primarily for delivery of goods or services and access by staff, not intended for use by the public.

### **Service Room:**

A room provided in a *building* to contain equipment and to perform activities associated with *building* services.

### **Service Space:**

A *space* provided in a *facility* to facilitate or conceal the installation of *facility* items such as chutes, ducts, pipes, shafts or wires.

**Sidewalk Ramp:** The ramped portion of sidewalk behind the depressed curb. (see curb ramp for further details)

### **Signage:**

Displayed of written word, symbols, pictorial, *tactile* and contracted Braille information.

### **Site:**

A parcel of land bound by a property line or a specific portion of a *public right-of-way*.

### **Site Improvement:**

Landscaping, paving for pedestrian and *vehicular ways*, outdoor lighting, recreational *facilities* added to a *site*.

### **Sleeping Accommodations:**

Rooms in which people sleep, for example, a dormitory.

### **Space:**

A definable area (e.g. room, toilet room, hall, *assembly area*, *entrance*, dormitory, storage room, alcove, courtyard or lobby).

### **Speaking Port**

A secure two way port through which a person can speak and respond.

### **Street:**

Any place or way, including any structure forming part of the place or way, which has been dedicated as a roadway, lane, avenue, footpath, walkway, road or highway pursuant to 'The Real Property Act' or which the public is ordinarily entitled to use for passage, with or without fee or charge.

### **Street Elements:**

*Street elements* include pedestrian elements, such as public art, benches, bicycle racks, and waste receptacles; and service infrastructure, such as fire hydrants, street signage, and traffic signal poles, that are *accessible* for *public use* and located within a *public right-of-way*.

### **Street Element Zone:**

The back-of-curb zone between the curb and the *accessible route*.

### **Streetscape:**

The collection of elements within and along the street right-of-way that define its identity, appearance, and functionality, including street furniture, public art, landscaping, trees, sidewalks, and pavement treatments, among others.

**Storey:**

That portion of a *building* that is situated between the top of any floor and the top of the floor next above it, and if there is no floor above it, that portion between the top of such floor and the ceiling above it.

**Structural Frame:**

The columns and the girders, beams, trusses and spandrels having direct connection to the columns and all other members (exclusive of door frames) which are essential to the stability of the *building* as a whole.

**Tactile:**

Describes an object that can be perceived using the sense of touch.

**Technically Not Feasible:**

Means, with respect to an *alteration* of a *building* or a *facility*, that it has little likelihood of being accomplished, because existing structural conditions would require moving or altering a load-bearing member which is an essential part of the *structural frame*; or other existing physical or *site* constraints prohibit modification or addition of necessary *elements*, *spaces* or features which are in full and strict compliance with the minimum requirements for new construction. (Inadequate budget is not an acceptable reason not to reduce *barriers*).

**Temporary Facilities:**

*Facility* that is not of permanent construction but that is extensively used, or is essential for *public use* for a period of time.

Examples of *temporary facilities* covered by this manual include, but are not limited to, reviewing stands, bleacher areas, temporary kiosks, temporary health screening services, temporary safe pedestrian passageways around a construction *site* or *temporary* public art. Structures and equipment directly associated with the actual processes of construction, such as scaffolding, bridging, materials hoists, or construction trailers are not included.

**Truncated Domes:**

Small domes with flattened tops that are inset into paving as *tactile* warnings at transit platforms, stair and ramp landings and other potential hazards. They also act as warnings and directional cues at curb edges within sidewalk slopes.

**Vehicular Way:**

A route intended for vehicular traffic, such as a *street*, driveway or parking lot.

**Visitable:**

The ability of a dwelling unit to offer a reasonable level of access to accommodate visitors with *disabilities*, elderly persons or residents who may be temporarily *impaired* - allowing a person to access the dwelling safely via a level entry, manoeuvre through an entry door and utilize a main floor toilet.

**Walk:**

An exterior pathway with a prepared surface intended for pedestrian use, including general pedestrian areas, such as plazas and courts.

**Wayfinding:**

*Wayfinding* is a term used to describe the spatial problem-solving process that a person uses to reach a destination. A mental 'map' is formed of the overall setting and the desired destination. This map is based on information obtained from orientation cues that are available from the setting's environment. These cues include not only *signage*, but also overall spatial forms, structures, sounds, surface textures, colours, illumination levels, architectural features, etc. *Wayfinding* cues should reduce complexity and increase consistency in an environment.

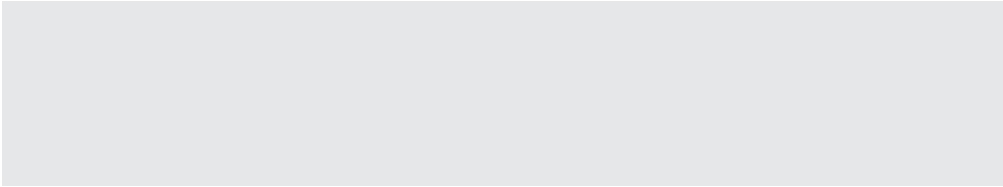

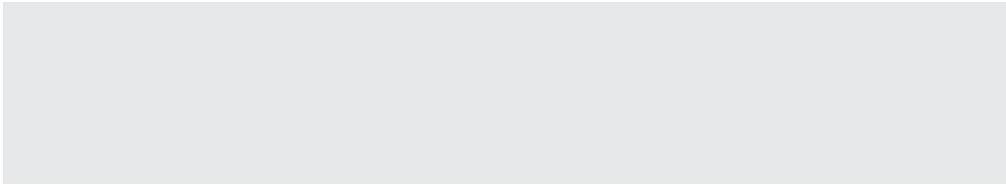

## **SCOPE AND APPLICATION**

# SCOPE AND APPLICATION

## GENERAL APPLICATION

Subject to the implementation criteria specified in the document introduction, the requirements of this design standard are

- applicable to all newly constructed and *retrofitted facilities* owned, leased or operated by the member organization of the City of Winnipeg; and
- encouraged for all other *facilities*, whether new or *retrofitted*.
- Required under the Winnipeg Zoning by-law for Pedestrian Connections where applicable. See section 1.1.3.1

All areas of newly designed or newly constructed *facilities* and altered portions of existing *facilities* shall comply with this manual, unless otherwise provided in this section or as specified in Sections 1.4 General Context Specific Requirements, 2.3 Exterior Context Specific Requirements and 3.6 Interior Context Specific Requirements.

The design requirements of this manual apply to *temporary facilities*, as well as permanent *facilities*.

This standard applies to both public and employee spaces

The design requirements of this manual do not apply to:

- privately owned houses, including semi-detached houses, town houses, row houses and boarding or

- rooming houses with fewer than 8 boarders or roomers;
- *buildings* of Group F Division 1 occupancy, as defined by the *MBC*; and
- *buildings* which are not intended to be occupied as a place of daily or full-time activity including but not limited to automatic telephone exchanges, pump houses, sewage treatment and water treatment facilities and substations.

## APPLICATION BASED ON FACILITY USE

The specific *facility* types listed in Sections 1.4 General Context Specific Requirements, 2.3 Exterior Context Specific Requirements and 3.6 Interior Context Specific Requirements shall comply with the provisions specified throughout the entire document, where applicable.

Where a *facility* contains more than one use covered by a special application section 9(i.e. employee and public), each portion shall comply with the requirements for that section in addition to all other general provisions (i.e. community centre/ arena/ pool).

## WORK AREAS AND EMPLOYEE-DESIGNATED AREAS

All *facilities* shall be *accessible* for employees, as well as patrons/ users. All areas intended for use by employees shall be designed and constructed to comply with the design requirements of this manual, including access through

doors into all offices.

## RETROFITTING, ALTERATIONS AND ADDITIONS

Each *addition* to an existing *facility* shall be regarded as an *alteration*.

(Note: an alteration may or may not require further *MBC* upgrades).

Each *space* or *element* added to the existing *facility* shall comply with the applicable provision(s) of this manual.

No *alteration* shall decrease or have the effect of decreasing accessibility or usability of an existing *facility* to below the requirements for new construction at the time of *alteration*.

If existing *elements*, *spaces* or common areas are altered, then each such altered *element/space/feature/area* shall comply with all applicable provisions.

If *alterations* of single *elements*, when considered together, amount to an *alteration* of a room or *space* in a *facility*, the entire *space* shall be made *accessible*.

No *alteration* of an existing *element*, *space* or area of a *facility* shall impose a requirement for greater accessibility than that which would be required for new construction.

If an escalator or stairs are proposed as a means of access where none existed previously, and major structural modifications are necessary for such installations, then a means of *accessible* access



shall also be provided.

If a planned *alteration* entails alterations to an *entrance*, even though the *facility* has another *accessible entrance*, the *entrance* being altered is required to be *accessible*.

If the alteration work is limited solely to the electrical, mechanical or plumbing system, or to hazardous material abatement, or to automatic sprinkler *retrofitting*, and does not involve the alteration of any *elements* or *spaces* required to be *accessible* under these guidelines, then this manual does not apply (except for alarms, and assistive listening systems).

An *alteration* that affects the usability of or access to an area containing a primary function shall be made to ensure that, to the maximum extent feasible, the path of travel to the altered area, the washrooms, and drinking fountains serving the altered area are readily *accessible* to and usable by individuals with *disabilities*.

Where the provision of *accessible* features is *technically not feasible*, and the manual allows a reduction of maneuvering *space* from the requirements for new construction, the reduced dimensions are minimums. Where possible, larger maneuvering *spaces* must be provided.

### EQUIVALENT FACILITATION

In a *retrofit* situation where the requirements of a section of this manual are *technically not feasible* to implement, equivalent facilitation may be proposed. Equivalent facilitation proposals shall be referred to the relevant member organization of the City of Winnipeg for review and approval on an individual basis. Refer also to 'Implementation and Enforcement' found in the document introduction.

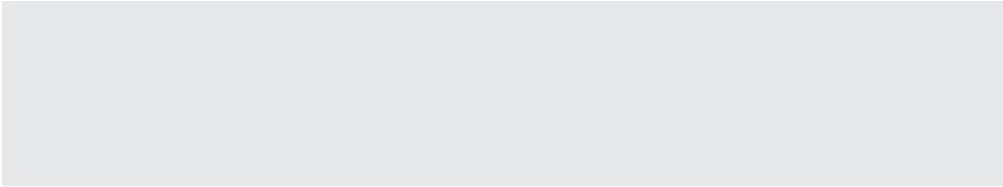

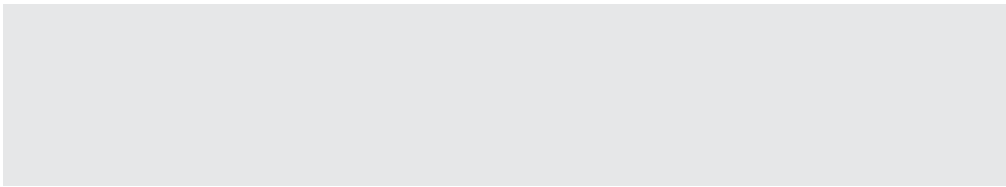

## **GENERAL STANDARDS**

# GENERAL STANDARDS

## 1.1.1 General Space and Reach Requirements

### RATIONALE

The dimensions and maneuvering characteristics of wheelchairs and other mobility devices are as varied as the people who use them. Traditionally, accessibility standards have taken a conservative approach to wheelchair maneuverability, reflecting the needs of a physically strong individual using a standard wheelchair. Such an approach excludes the many users without such a degree of strength or using a larger mobility device. This standard more accurately reflects the vast array of equipment that is used by persons to access and use facilities, as well as the diverse range of user ability. This standard incorporates more generous *space* requirements, particularly related to the dynamic movement of people using wheelchairs, scooters or other assistive devices.

### APPLICATION

*Space* and reach range provisions for persons who use wheelchairs, scooters and other mobility devices shall comply with this section.

### DESIGN REQUIREMENTS

The *clear space* required for a wheelchair to make a 360-degree turn is 1830 mm (72 in.) in diameter as shown in Figure 1.1.1.3. For a scooter to make a 360-degree turn a *clear space* of 2440 mm (96 in.) diameter is required. See figure 1.1.1.4

Although providing for the 360-degree scooter turning space is preferred, the 360-degree wheelchair space is acceptable.

The minimum *clear floor or ground space* required to accommodate a single, stationary wheelchair or scooter and occupant shall be 760 mm (30 in.) x 1370 mm (54 in.) as shown in Figures 1.1.1.6 and 1.1.1.7.

The minimum *clear floor or ground space* for wheelchairs or scooters may be positioned for forward or parallel approach to an object.

*Clear space* for wheelchairs may be part of the knee or toe space required under all objects.

One full, unobstructed side of the *clear space* for a wheelchair or scooter shall adjoin or overlap an *accessible route* or adjoin another

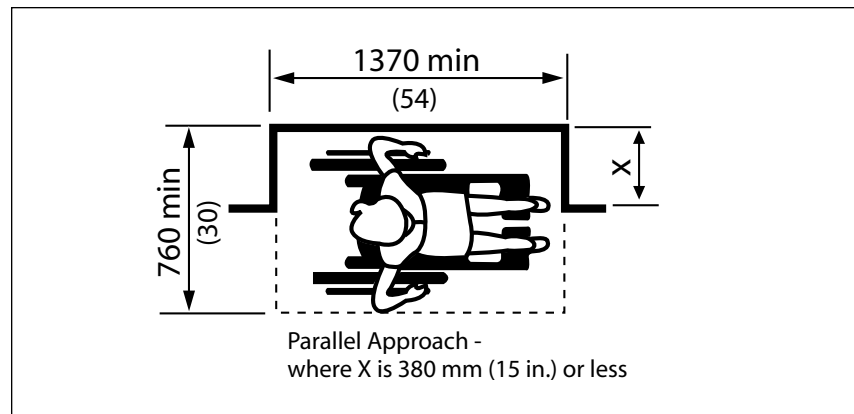

Figure 1.1.1.1 Wheelchair Clearances at Alcove

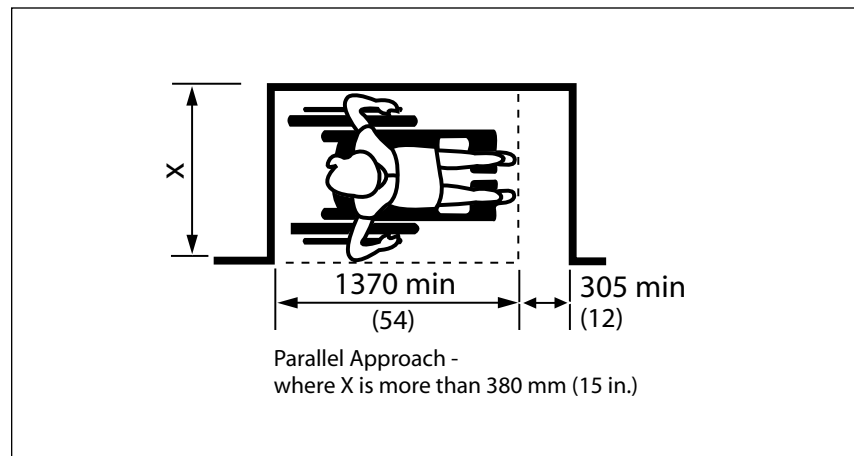

Figure 1.1.1.2 Wheelchair Clearances at Alcove

1.1.1 General Space and Reach Requirements (continued)

wheelchair *clear space*. If a *clear space* is located in an alcove or otherwise confined on all or part of three sides, additional maneuvering clearances shall be provided as shown in Figures 1.1.1.1, 1.1.1.2, 1.1.1.8 and 1.1.1.9.

The surface of *clear floor or ground spaces* for wheelchairs and scooters shall comply with Sections 2.1.1 Exterior Ground Surfaces and 3.1.1 Interior Floor Surfaces.

If the *clear space* only allows forward approach to an object, the maximum high forward reach allowed shall be 1200 mm (47 in.) see figure 1.1.1.13. The minimum low forward reach is 400 mm (15-3/4 in.). If the high forward reach is over an obstruction, reach and clearances shall be as shown in Figures 1.1.1.14 and 1.1.1.15.

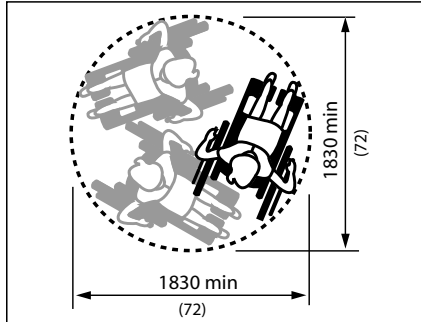

Figure 1.1.1.3 Wheelchair 360° Turning Space (acceptable except where larger space is specified ie. Individual Washroom)

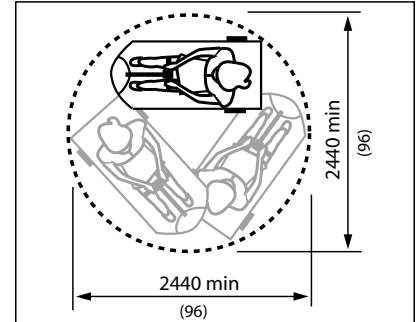

Figure 1.1.1.4 Scooter 360° Turning Space (Preferred)

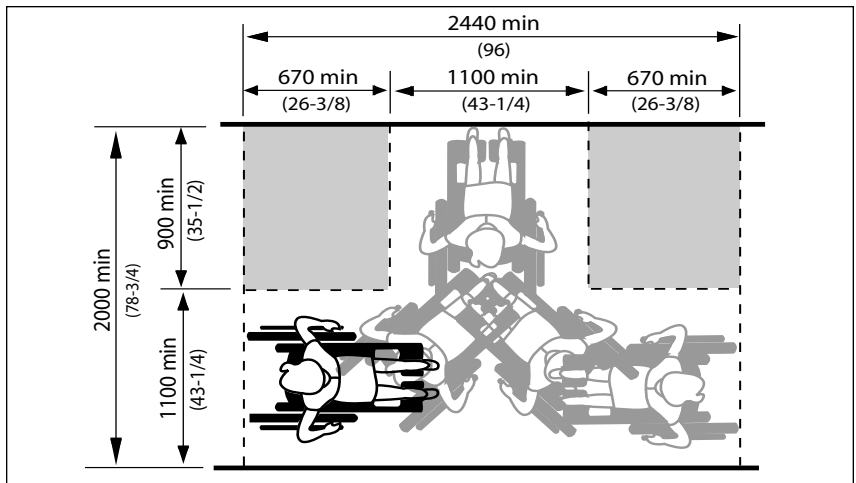

Figure 1.1.1.5 Wheelchair 180° Turning Space

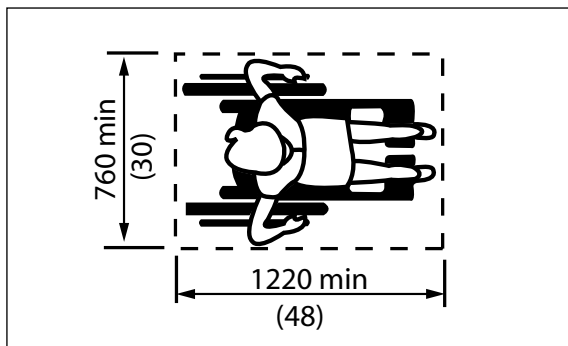

Figure 1.1.1.6 Clear space for Wheelchair

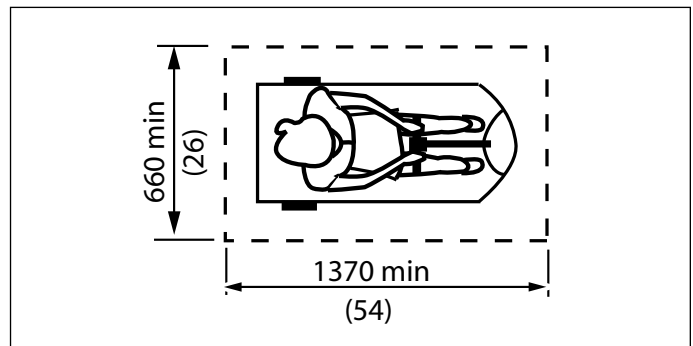

Figure 1.1.1.7 Clear space for Scooter

1.1 GENERAL ACCESS AND CIRCULATION

# GENERAL STANDARDS

## 1.1.1 General Space and Reach Requirements (continued)

If the *clear space* allows parallel approach to an object, the maximum high side reach allowed shall be 1370 mm (54 in.) Figure 1.1.1.10 and the low side reach no less than 325 mm (13 in.) above the floor. If the side reach is over an obstruction, the reach and clearances shall be as shown in Figure 1.1.1.12. All controls for the operation of *facility* services or safety devices, including electrical switches, thermostats and intercom switches, shall be mounted 850 mm (33-1/2 in.) to 1200 mm (47 in.) above the floor as per Section 3.5.1 Control and Operating Mechanisms.

If a guide dog or cane are in use a minimum of 1070 mm (42) of clear space is required (Figure 1.1.1.16). A cane users sweep movement can vary from 900mm (35-1/2) - 1500 mm (60) ( Figure 1.1.1.17). A single cane user requires a clear width of 700 mm (28) min. A person walking with 2 walking aids needs 920 mm (36) min. for a comfortable gait.

Note: In Diagrams 1.1.1.12 and 1.1.1.14, X shall be less than or equal to 635 mm (25); Z shall be greater than or equal to X.

When X is less than or 510 mm (20), then Y shall be 1220 mm (48) maximum.

When X is 510 to 635 mm (20 - 25), then Y shall be 1120 mm (44) maximum.

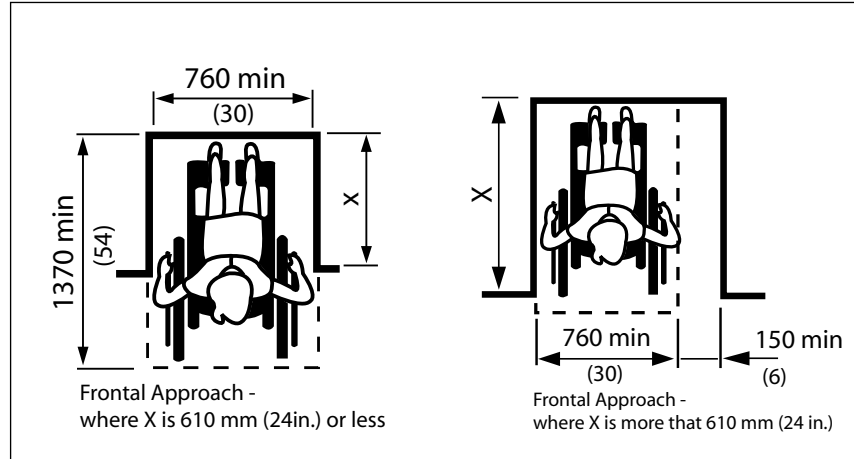
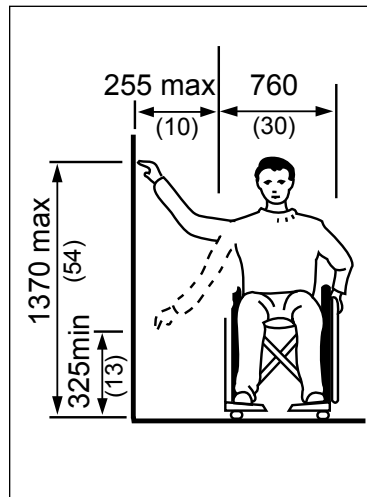
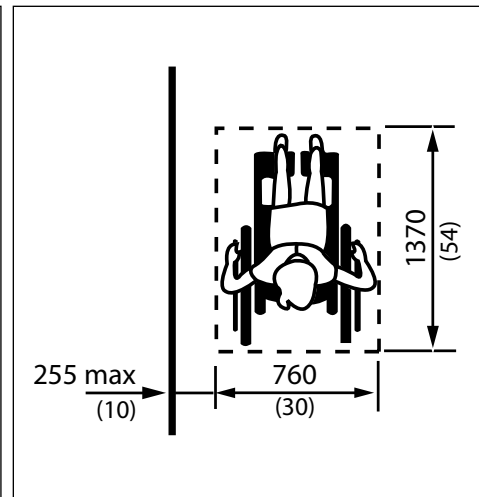

Figure 1.1.1.8 and 1.1.1.9 Wheelchair Clearances at Alcove



Figures 1.1.1.10 Wheelchair Side Reach Allowances



Figures 1.1.1.11 Maximum Distance to Wheelchair

1.1.1 General Space and Reach Requirements (continued)

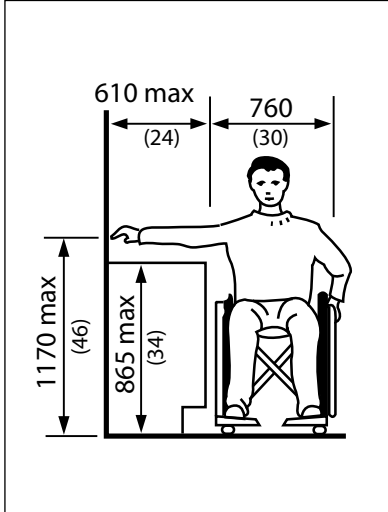

1.1.1.12 Wheelchair Reach allowance over an Obstruction

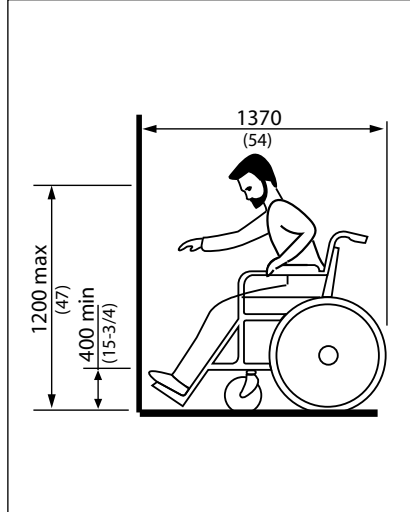

Figures 1.1.1.13 Wheelchair Forward Reach Allowances

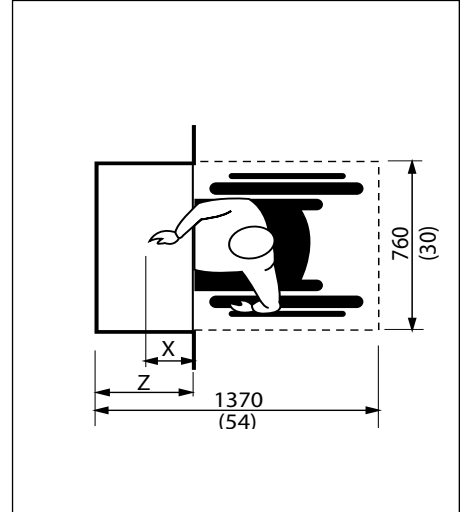

Figures 1.1.1.14 Forward Reach over an Obstruction

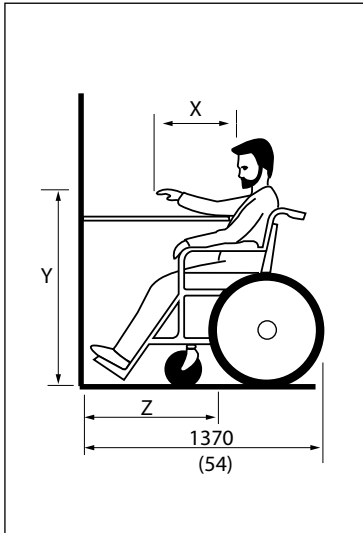

Figures 1.1.1.15 Forward Reach over an Obstruction

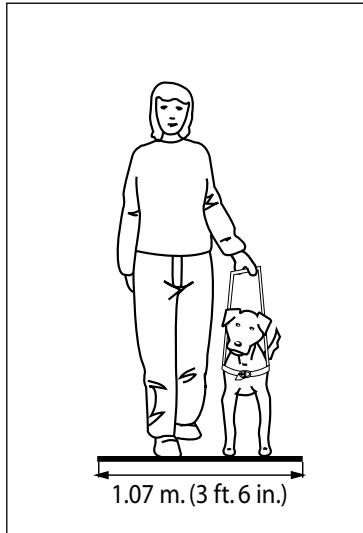

Figures 1.1.1.16 Clear Width for Persons with Service Dog.

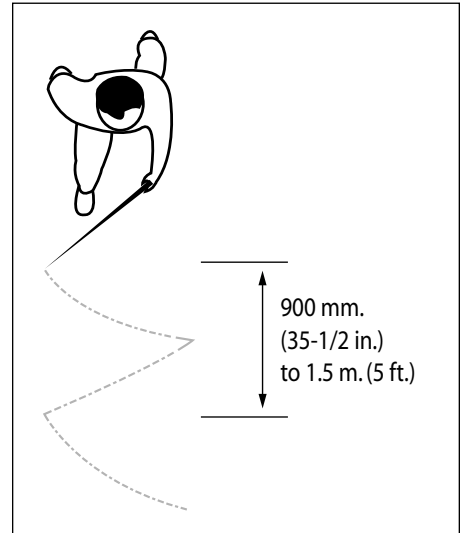

Figures 1.1.1.17 Cane Detectable Range

1.1 GENERAL ACCESS AND CIRCULATION

# GENERAL STANDARDS

## 1.1.2 Protruding and Overhead Objects

### RATIONALE

The creation of pathways free from protruding objects or free-standing obstacles is important to all *facility* users. An object protruding from a wall above the detection range of a cane is dangerous for an individual with a vision *impairment* or a pedestrian distracted by a conversation. The underside of stairways is a common overhead hazard. Temporary construction *barriers* can also be hazardous if their lower edge is too high to be detected by a person using a long white cane for mobility. Detectable surfaces around freestanding obstacles, such as light standards, are advantageous to anyone using a pathway.

### APPLICATION

Protruding objects from a wall, ceiling or other location shall comply with this section.

### DESIGN REQUIREMENTS

Protruding objects shall not reduce the *clear* width required for an *accessible route* or maneuvering *space*.

Objects protruding from walls with their outer edges between 680 mm (26-1/2 in.) and 2500 mm (98 5/8 in.) from the floor shall protrude not more than 100 mm (4 in.) into pedestrian areas, such as walkways, halls, corridors, passageways or aisles. i.e. parking ticket dispensers or signs (temporary or permanent)

Objects attached to a wall with their outer edges at or below 680 mm (26-1/2 in.) from the floor may protrude any amount provided they do not narrow the clear *accessible route* to less than 1.5 m .

Objects that protrude more than 100 mm (4 in.) into pedestrian areas, such as walkways, halls, corridors, passageways or aisles, shall be identified with a *detectable warning* surface of at least 300 mm (11-3/4 in.) around the object, installed flush with the walkway surface or a guard protecting from accidental encroachment.

Freestanding objects shall not have any overhang of more than 300 mm (12 in.) between 680 mm

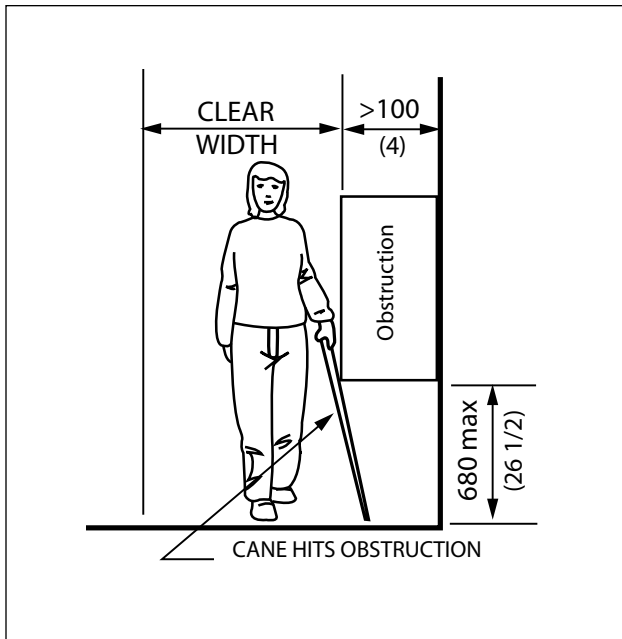

Figure 1.1.2.1 Limits of Protruding Objects

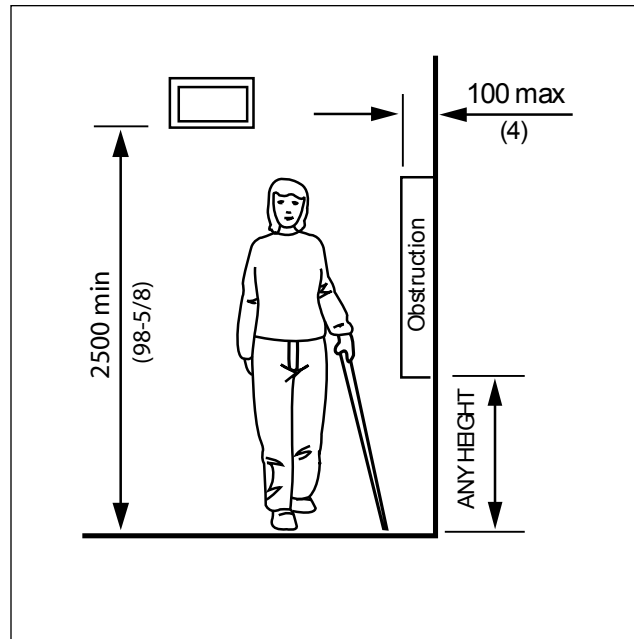

Figure 1.1.2.2 Limits of Protruding Objects



**1.1.2 Protruding and Overhead Objects (continued)**

(26-1/2 in.) and 2500 mm (98 5/8 in.) from the ground or floor.

The maximum height of the bottom edge of freestanding objects with a space of more than 300 mm (11-3/4 in.) between supports shall be 680 mm (26-1/2 in.) from the ground or floor.

The minimum *clear* headroom in pedestrian areas, such as walkways, halls, corridors, passageways, or aisles and along multi-use pathways, shall be a minimum of

- 2500 mm (98 1/2 in.) for items such as trees, awnings and business signs, etc.;
- 2400 mm for traffic signal heads; and
- 2100 mm (82-3/4 in.) for transit and traffic control signs.

A detectable *guard*: a guardrail or other *barrier* having its leading edge at or below 680 mm (26-1/2 in.) from the floor shall be provided where the headroom of an area adjoining an *accessible route* is reduced to less than 2500 mm (82-3/4 in.).

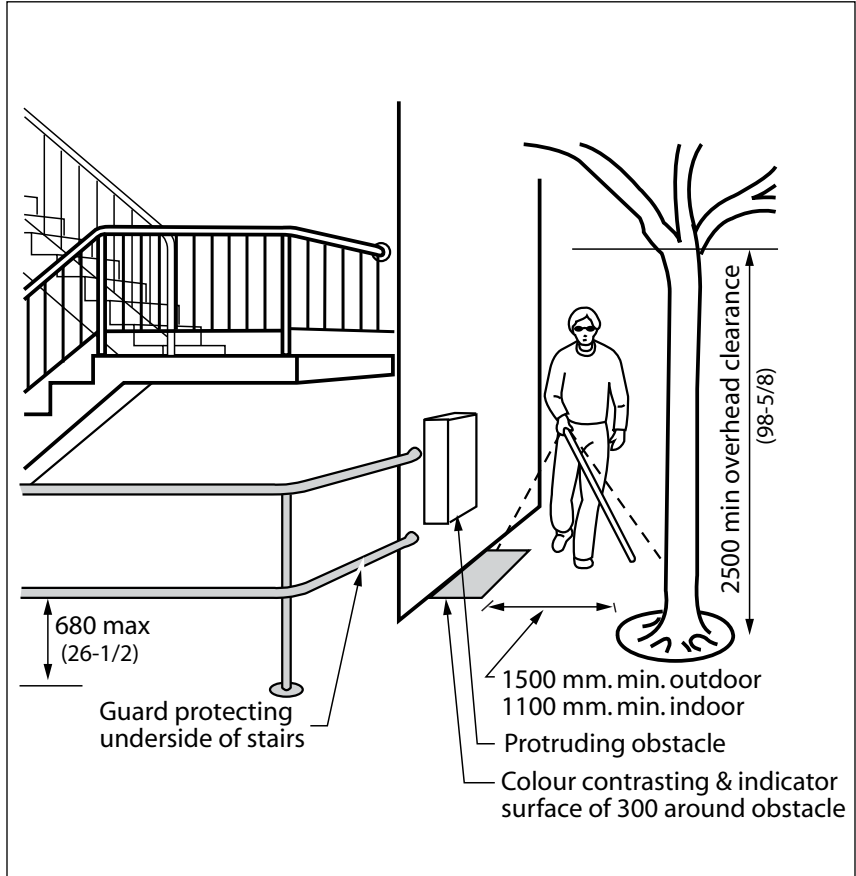

**Figure 1.1.2.3** Overhead Obstructions

**RELATED SECTIONS**

- 1.1.3 Accessible Routes  
Paths and Corridors
- 1.2.1 Texture, Finishes and  
Colour
- 1.2.6 Detectable Warning  
Systems
- 2.1.1 Exterior Ground Surfaces
- 2.1.3 Streetscape
- 2.2.2 Plantings
- 3.1.1 Interior Floor Surfaces

**1.1 GENERAL ACCESS AND CIRCULATION**

# GENERAL STANDARDS

## 1.1.3 Accessible Routes, Paths and Corridors

### RATIONALE

Accessible routes, paths and corridors are designed to reflect good *wayfinding* principles.

*Tactile* maps and/or recorded instructions can augment orientation cues and enable people to find their way throughout a *facility* independently, even in complex settings. A well-designed setting can have good site lines and be easy to understand and move through.

Routes of travel to and through a *facility* should address the full range of individuals that may use them. They must provide the *clear* width necessary for persons using wheelchairs or scooters, those pushing strollers, those with vision loss or those travelling in pairs. Consideration should be given both to the width of items, such as wheelchairs and scooters, and also their maneuverability. While a corridor may be wide enough for a person to drive a scooter in a straight line, it may not be possible to make a turn around a corner.

Gradual sloped walkways are the preferred means of changing level, rather than *ramps* or lifts.

Vertical elements such as public art, tree guards, signal receiving/transmission towers, benches, utility boxes or bike racks, shall not infringe on the *clear* width of access routes, paths or corridors. Horizontal elements such as patterned coloured concrete or pavers shall be used as *delectors* and not within the *accessible route*.

Strong visual *colour contrasts*, either light-on-dark or dark-on-light, and/or *tactile* pathways set into the edges of floors or sidewalks used to assist individuals with vision *impairments* to negotiate an environment providing upmost efficiency. Edge protection that guards a change in level is an important safety feature for all users.

Covered routes are preferred in exterior locations, or alternatively the incorporation of snow-melting systems. Snow accumulation at routes should be removed completely after each snow fall.

### APPLICATION

All routes, paths or corridors shall comply with this section.

At least one *accessible route* complying with this section shall

be provided within the boundary of the *site* from *accessible* parking *spaces*, passenger loading zones (if provided), and public *streets* or sidewalks to the *accessible facility entrance* they serve. The *accessible route* shall, to the maximum extent feasible, coincide with the route for the general public.

At least one *accessible route* shall connect *accessible buildings, facilities, elements* and *spaces* that are on the same *site*. It is preferable to have all routes *accessible*.

*Accessible routes* are permitted to include *ramps, curb ramps, elevators* or other elevating devices, platform lifts as per Section 3.1.6. Stairs are permitted where there exists a difference in elevation provided an alternative *accessible route* exists.

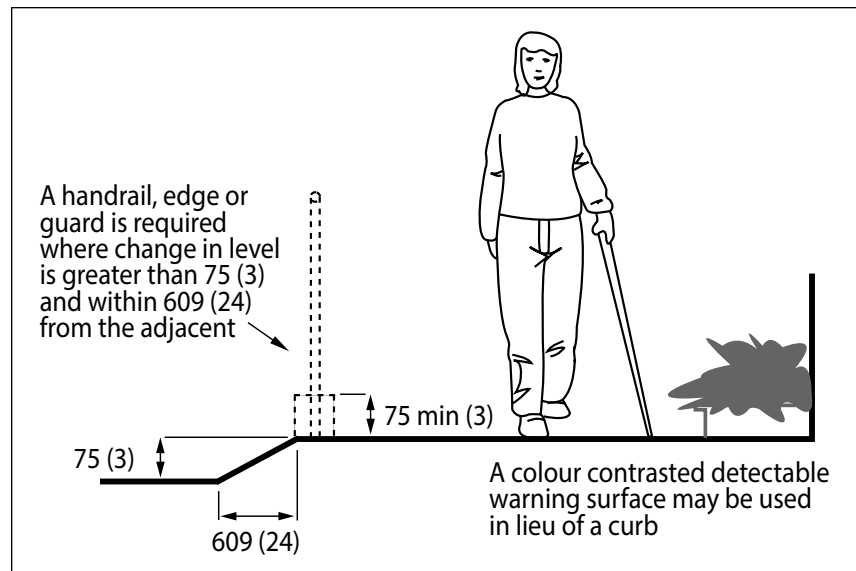

Figure 1.1.3.1 Edge Protection

**1.1.3 Accessible Routes, Paths and Corridors (continued)**

Where a *facility* is on a sloped *site* and is accessible from *street* level at different floors, persons with *disabilities* shall not be required to travel outside to gain access to another floor.

Except where essential obstructions in a work area would make an *accessible route* hazardous, an *accessible route* shall connect *accessible entrances* with all *accessible spaces* and *elements* within the *facility*. An *accessible route* complying with this section shall be provided within all normally *occupiable* floor areas. It is not appropriate to have only some areas *accessible*.

Exceptions: The provision of an *accessible route* does not apply:

- to *service rooms*;
- to elevator machine rooms;
- to janitor rooms;
- to *service spaces*;
- to *crawl spaces*;
- to *attic* or *roof spaces*;
- to high-hazard industrial occupancies;
- within portions of a floor area with fixed seats in an *assembly occupancy* where these portions are not part of an *accessible route* to *spaces* designated for wheelchair use; or
- within a suite of residential occupancy.

**DESIGN REQUIREMENTS**

The minimum *clear* width of *accessible routes* shall be 1100

mm (43-1/4 in.) except:

- for public exterior routes, it shall be 1500 mm (59 in.);
- at *ramps* as per Section 1.1.5 Ramps;
- at doors as per Section 3.1.3 Doors;
- where additional maneuvering *space* is required at doorways;
- at U-turns around obstacles less than 1220 mm (48 in.) wide, it shall be 1220 mm (48 in.). See Figure 1.1.3.4; and
- where *space* is required for two wheelchairs to pass, it shall be 1830 mm (72 in.). This passing space can include the recess of a door opening.

Every off-street *accessible route* less than 1830 mm (72 in.) wide shall be provided with an unobstructed passing *space* of not less than 1830 mm (72 in.) in width

and 1830 mm (72 in.) in length, located not more than 30 meters (98 ft. 5 in.) apart.

*Accessible routes* shall:

- have a longitudinal grade not steeper than 1:20 (5%); and
- have minimal *cross slope*, but never steeper than 1:50 (2%). Where *technically not feasible* to achieve 2%, maximum shall never exceed 1:25 (4.0%).

A *ramp* is required when an *accessible route*, path or corridor has a longitudinal grade steeper than 1:20 (5%) in compliance with Section 1.1.5 Ramps.

Wall surfaces in corridors shall be non-abrasive below 2000 mm (78-3/4 in.) Whenever possible, dead-end corridors should be avoided. Where dead-end corridors cannot be avoided, they shall be no greater than 6000 mm

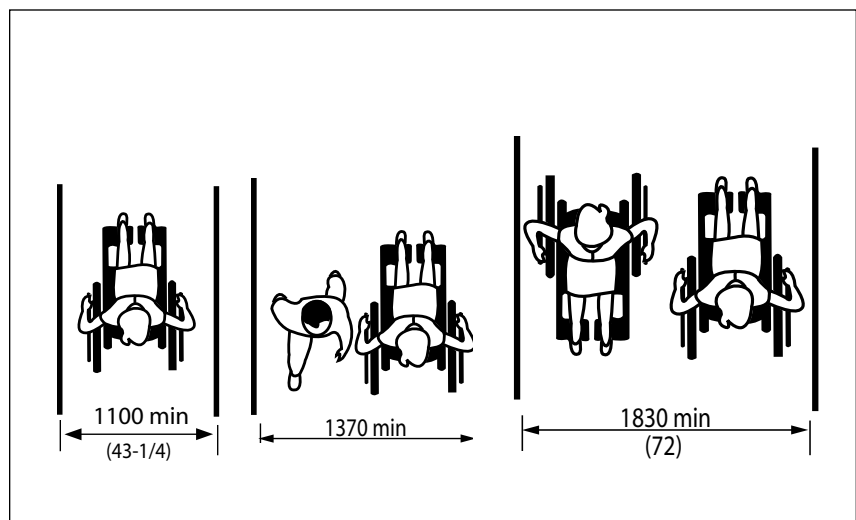

**Figure 1.1.3.2** Recommended Minimum Access Widths (best practice provides 2000 mm minimum where possible)

# GENERAL STANDARDS

## 1.1.3 Accessible Routes, Paths and Corridors (continued)

(19 ft.-8 in.) in length, and feature a 2440 mm (96 in.) diameter turn-around *space* at the end of the corridor.

Where the edges of *accessible* routes intersect with a vehicular route, they shall be separated from it by:

- a curb with a *curb ramp*; or
- a railing or *barrier*; or
- a *truncated dome detectable warning* surface in compliance with Section 1.2.6 Detectable Warning Systems. and installed in accordance with the City of Winnipeg Standard Construction Specifications

Except at stairs, performance platforms, loading docks, and sidewalks adjacent to roadways and parking lots, where an unexpected drop off is created at the edge of an accessible route, path or corridor that exceeds 75 mm (3 in.) above an adjacent surface within 609 mm (24) of that surface they shall be protected by (see Figure 1.1.3.1):

- a continuous *colour contrasting* curb at least 75 mm (3 in.) high; or
- by a continuous *truncated dome detectable warning surface* which is at least 600 mm (23-1/2 in.) wide and in compliance with Section 1.2.6 Detectable Warning Systems.
  - indoor edges warrant greater flexibility in colour and material used.
  - outdoor edges must

follow the City of Winnipeg Standard Construction Requirements.

- an 865 mm - 915 mm (34 in - 36 in.) high *handrail* in compliance with 1.1.7 Handrails and Guards; or
- a *guard* which meets the requirements of the *MBC* and complies with 1.1.7 Handrails and Guards. Refer to Figure 1.1.3.1.

Protection from grade changes exceeding 75 mm (3 in.) along the edge of a sidewalk or walkway shall be provided by

- a curb not less than 75 mm (3 in.) high; or
- a cane detectable railing or a *barrier*; or
- a median not less than 400 mm (16 in.) wide, constructed of a textured surface that contrasts from the walkway.

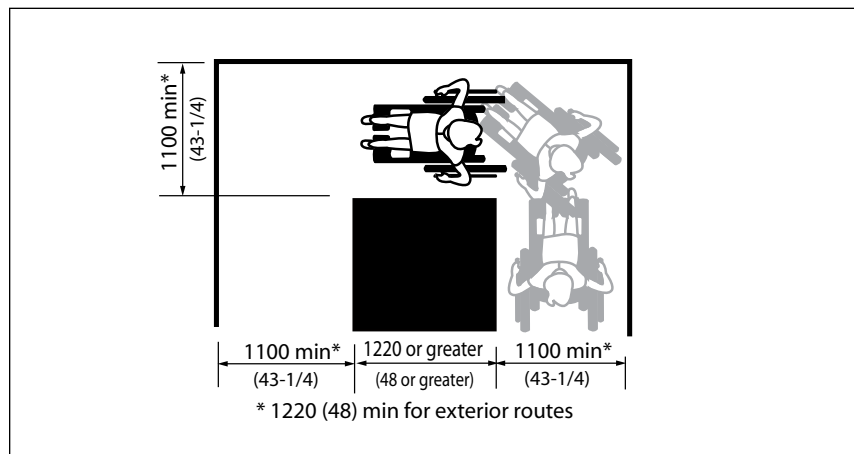

Figure 1.1.3.3 Turn around an Obstacle

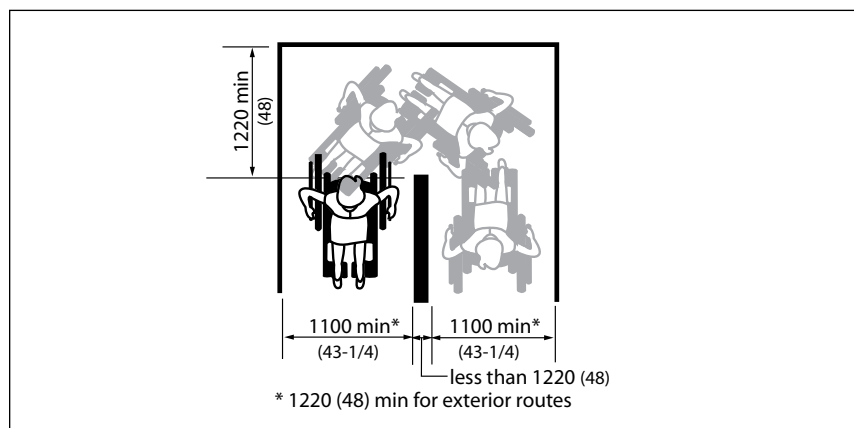

Figure 1.1.3.3 Turn around an Obstacle

**1.1.3 Accessible Routes, Paths and Corridors (continued)**

*Accessible* routes through off *street* parking lots shall not require people to pass behind parked vehicles. If the *accessible* route is separated from the parking space by a curb, railing or other *barrier* there must be an accessible opening within 50 ft. of the accessible parking space.

Where there is a change in direction along an *accessible route* and the intended destination of the route is not evident, directional *signage* shall be provided.

All portions of *accessible routes* shall be equipped to provide a level of illumination of at least 50 lux (4.6 ft-candles). Exception: Outdoor *park* settings where routes are not normally illuminated.

Provide designated areas for snow piling from all major exterior routes and away from accessible parking stalls or paths of travel.

All *accessible routes* shall incorporate level rest areas that are a maximum of 30 meters (98.5 ft.) apart.

Seating (benches) shall be spaced no more than 300 meters - 400 meters (985 ft - 1312 ft.) apart and be in compliance with Section 1.3.6 Seating.

**RELATED SECTIONS**

- 1.1.5 Ramps
- 1.1.7 Handrails and Guards
- 1.2.1 Texture, Finishes and
- 1.2.4 Signage
- 1.2.6 Detectable Warning Systems
- 1.3.3 Elevated Areas and Platforms
- 1.3.6 Seating
- 2.1.1 Exterior Ground Surfaces
- 2.1.3 Streetscape
- 2.1.2 Exterior Lighting
- 3.1.1 Interior Floor Surfaces
- 3.5.3 Interior Lighting
- 3.5.4 Interior Glare and Light Sources

# GENERAL STANDARDS

## 1.1.3.1 Private Development Requirements for Pedestrian Routes

### INTRODUCTION

This section provides the technical standards for application of regulations in the Winnipeg Zoning By-Law for Pedestrian Connections. It also serves as a guide for pedestrian routes in private development.

It supports OurWinnipeg and the City of Winnipeg's Universal Design Policy. The document addresses a diverse range of user needs, including people with various impairments. It embraces the spirit of universal design through the creation of inclusive environments. The Manitoba Building Code contains requirements for pedestrian walkways that must be followed.

### RATIONALE

Routes of pedestrian travel to building *entrances* should be easy to navigate by any customer, resident, student, visitor or employee in order that full participation can be realized. Routes of pedestrian travel to building entrances shall address the full range of individual needs of the pedestrians that may use them.

### APPLICATION

In accordance with the Winnipeg Zoning By-Law, where provision of a Pedestrian Connection is required, the connection(s) shall meet the standard of an accessible pedestrian route, per the Design Requirements identified below. Recommended

Design Criteria, immediately below the Design Requirements, are not required but are encouraged.

### DESIGN REQUIREMENTS

#### Accessible Pedestrian Routes shall:

- have a minimum clear (unencumbered) width of 1500 mm (59in.)
- have a stable, firm, slip resistant and glare-free base for the path of travel (i.e. concrete, asphalt, pavers)
  - if pavers are used for the path of travel, they shall be spaced not more than 6 mm (1/4 in.) or at their joined edge, be beveled with a space not greater than 13 mm (1/2 in.). See Figures 2.1.2.1 and 2.1.2.2 for more information
- have a longitudinal grade not greater than 1:20. If the grade is greater than 1:20 it is considered a ramp and must be designed in accordance with the requirements of Manitoba Building Code 3.8.3.4
- have a crossslope, not to exceed 1:50 (2%). If not technically feasible to achieve 1:50 (2%) then a maximum of 1:25 (4%) is allowable
- Exclude grates or catch basins within them unless they meet Figure 2.1.1.3 of this standard
- If the route is required by the Winnipeg Zoning By-Law

to differ in both texture and appearance, the route shall be delineated in accordance with the following standards:

- the base and edges of the route, or at minimum the edges of the route, shall differ in texture (i.e. pavers, texture embedded concrete or asphalt) and be a minimum 70% *colour contrasted* from the surrounding surface material. If a planting bed or grass exists on either side of the route, that will suffice for delineation of the pathway.

If the route is required by the Winnipeg Zoning By-Law to differ in appearance only, the route shall be delineated in accordance with the following standards:

- the base and edges of the route, or at minimum of the edges of the route, shall be a minimum 70% colour contrasted (i.e. using paint or other material), from the surrounding surface material. If a planting bed or grass exists on either side of the route, that will suffice for delineation of the pathway.

### RECOMMENDED DESIGN CRITERIA

- Provide directional signage where there is a change in direction along an accessible route and where the intended destination of the route is not evident
- Ensure a level of illumination

### 1.1.3.1 Private Development Requirements for Pedestrian Routes (continued)

of at least 50 lux (4.6 ft-candles) along the entire route

- Employ colour and texture to define boundaries of objects from their background in the accessible route
- Provide visual identifiers to help everyone find an entrance
- Accessible routes through parking lots should not be located behind parked vehicles unless the route is separated from the parking area by a curb, railing or other *barrier*.

# GENERAL STANDARDS

## 1.1.4 Gates, Turnstiles and Revolving Doors

### RATIONALE

Gates, turnstiles and revolving doors should address the full range of users that may pass through them. Single-bar gates designed to be at a convenient waist height for ambulatory persons are at neck and face height for children and persons who use wheelchairs or scooters.

Revolving turnstiles or some revolving doors are a physical impossibility for a person in a wheelchair to negotiate. They are also difficult for persons using canes or crutches, or persons with poor balance. An adjacent opening of an appropriate width is essential for wheelchair access, as well as access for those using other mobility devices, strollers, walkers or delivery carts.

### APPLICATION

Gates, turnstiles and revolving doors shall comply with this section.

### DESIGN REQUIREMENTS

Where gates or openings are provided through fences or screens to *public use* areas, such openings shall be *accessible* (i.e., a minimum of 915 mm (36 in.) wide, to allow free passage of a person using a mobility device (see Figure 1.1.4.1, 1.1.4.2). Hardware should be suitable for independent use, and any closing device should not be significantly spring-loaded).

Where turnstiles, revolving doors or other ticketing control devices which are not wheelchair *accessible* are utilized, then a gate or opening which is *accessible* shall also be provided in the same location.

Turnstiles and revolving doors shall incorporate a pronounced *colour contrast*, to differentiate them from the surrounding environment.

Where gates are incorporated into a chain-link fencing system, the poles at either side of the gate shall incorporate a pronounced *colour contrast* from the fence and the surrounding environment.

### RELATED SECTIONS

- 1.1.1 Space and Reach Requirements
- 1.2.4 Signage
- 1.2.5 Information Systems
- 3.1.3 Doors
- 3.1.4 Windows, Glazed Screens and Sidelights
- 3.5.1 Controls and Operating Mechanisms
- 3.5.2 Card Access, Safety and Security Systems



1.1.4 Gates, Turnstiles and Revolving Doors (continued)

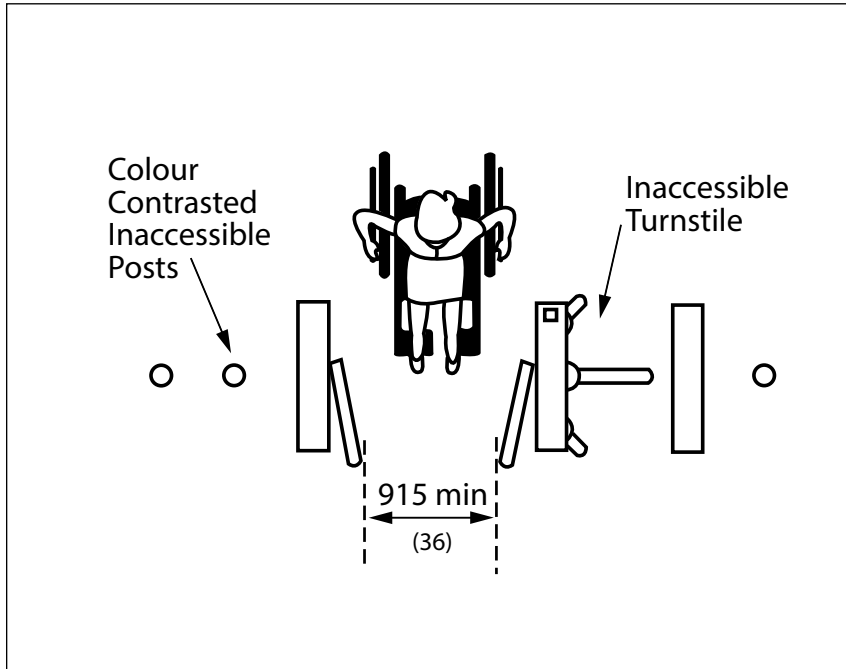

Figure 1.1.4.1 Wheelchair Access at Turnstile

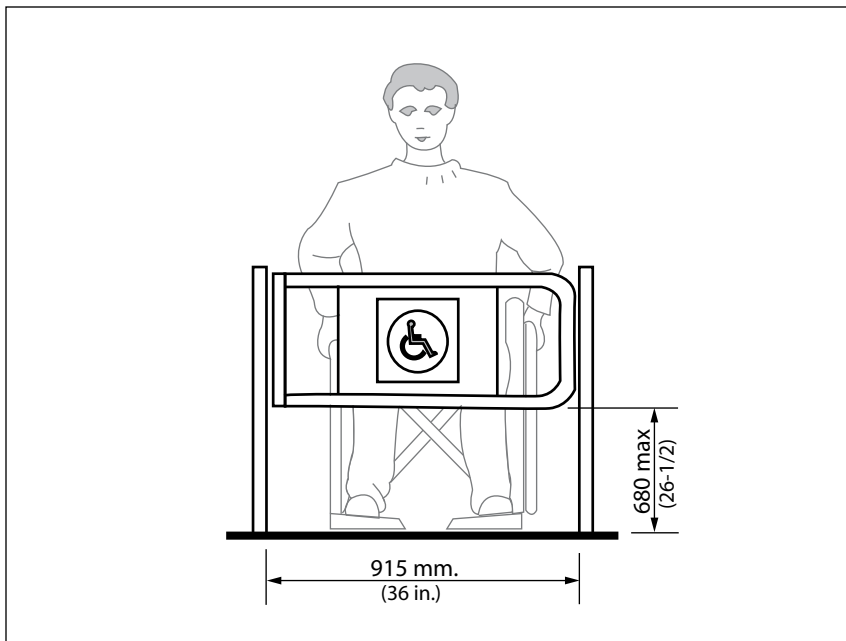

Figure 1.1.4.2 Wheelchair Access at Turnstile

1.1 GENERAL ACCESS AND CIRCULATION

# GENERAL STANDARDS

## 1.1.5 Ramps (excluding street curb ramps)

### RATIONALE

Where a change in level already exists or cannot be avoided, a properly designed *ramp* can provide access for those using wheelchairs, pushing strollers or moving packages on a trolley.

The design of the *ramp* is critical to its usefulness and safety. A steeply inclined *ramp* is difficult to ascend when using a wheelchair, and can increase the risk of the wheelchair tipping backwards. Descending a steep *ramp* can also be hazardous. Any *cross slope* will further increase the effort required to negotiate the *ramp*. Maneuvering *space* at the top and bottom are other important factors in a *ramps* usability. Level areas at points along a long *ramp* enable an individual to rest.

Curved *ramps* are not permitted. This applies to pedestrian bridges.

Lightly textured surfaces, edge protection and *handrails* all provide important safety functions. Dual height handrails are critical to assist a person in a wheelchair to pull themselves along or slow themselves down on a ramp.

Covered *ramps* are preferred in exterior locations, or alternatively the incorporation of snow-melting systems. Snow accumulation at *ramps* should be removed completely after each snow fall.

### APPLICATION

This section excludes street ramps. Where the slope of an accessible route is less than 1:20 (5%) there is no requirement for it

to be designed as a *ramp*.

Any part of an *accessible route* with a slope steeper than 1:20 (5%) shall be considered a *ramp* and shall comply with this section, except at curb ramps and sloped sidewalks on the street edge.

### DESIGN REQUIREMENTS

*Accessible ramps* shall be on an *accessible route* complying with Section 1.1.3 Accessible Routes, Paths and Corridors.

The surfaces of ramps and landings shall:

- not be carpeted;
- have a surface that is slip resistant;
- have a *colour contrast* to demarcate the leading edge of the landing, as well as the beginning and end of a ramp.

The *ramp slope* shall be between 1:15 (6.7%) and 1:20 (5%). In a *retrofit* situation where it is *technically not feasible* to provide a *ramp* with a *ramp slope* between 1:15 (6.7%) and 1:20 (5%), a *ramp slope* not steeper than 1:12 (8.3%) may be used. However, more gradual slopes are preferred.

*Ramps* shall have drainable landings that do not exceed 2% slope in any direction.

Where power door operators are installed, the landing surface shall never exceed 2% slope.

The maximum horizontal length between landings shall not

exceed 9 m (29 ft. - 6 in).

Excessively long ramps are not a recommended option. Consider a grade change or alternate place for the entrance where less slope surfacing will be required.

A ramp shall never terminate directly at a landing at the top of a stair.

Landings shall:

- be at least as wide as the widest *ramp* run leading to it;
- have a minimum size not less than 2440 x 2440 mm (96 x 96 in.) if located at the top or bottom of a *ramp* or if served by a doorway. (In a *retrofit* situation where creating a suitably sized landing is *technically not feasible*, the required landing size may be reduced to 1670 x 1670 mm. (65-3/4 x 65-3/4 in.));
- on an intermediate landing of a U-shaped *ramp* have a length not less than 1670 mm (65-3/4 in.) and a width not less than 2440 mm (96 in.) as per Figure 1.1.5. In a *retrofit* situation where creating a suitably sized landing is *technically not feasible*, the required landing width may be reduced to 2120 mm (84in);
- on an intermediate landing at the corner of an L-shaped *ramp* have a length and width not less than 1670 mm (65-3/4 in.) as per Figure 1.1.5.1; and
- on an intermediate landing at a straight *ramp* have a length not less than 1670 mm (65-3/4 in.) as per Figure 1.1.5.1.

## 1.1 GENERAL ACCESS AND CIRCULATION

1.1.5 Ramps (continued)

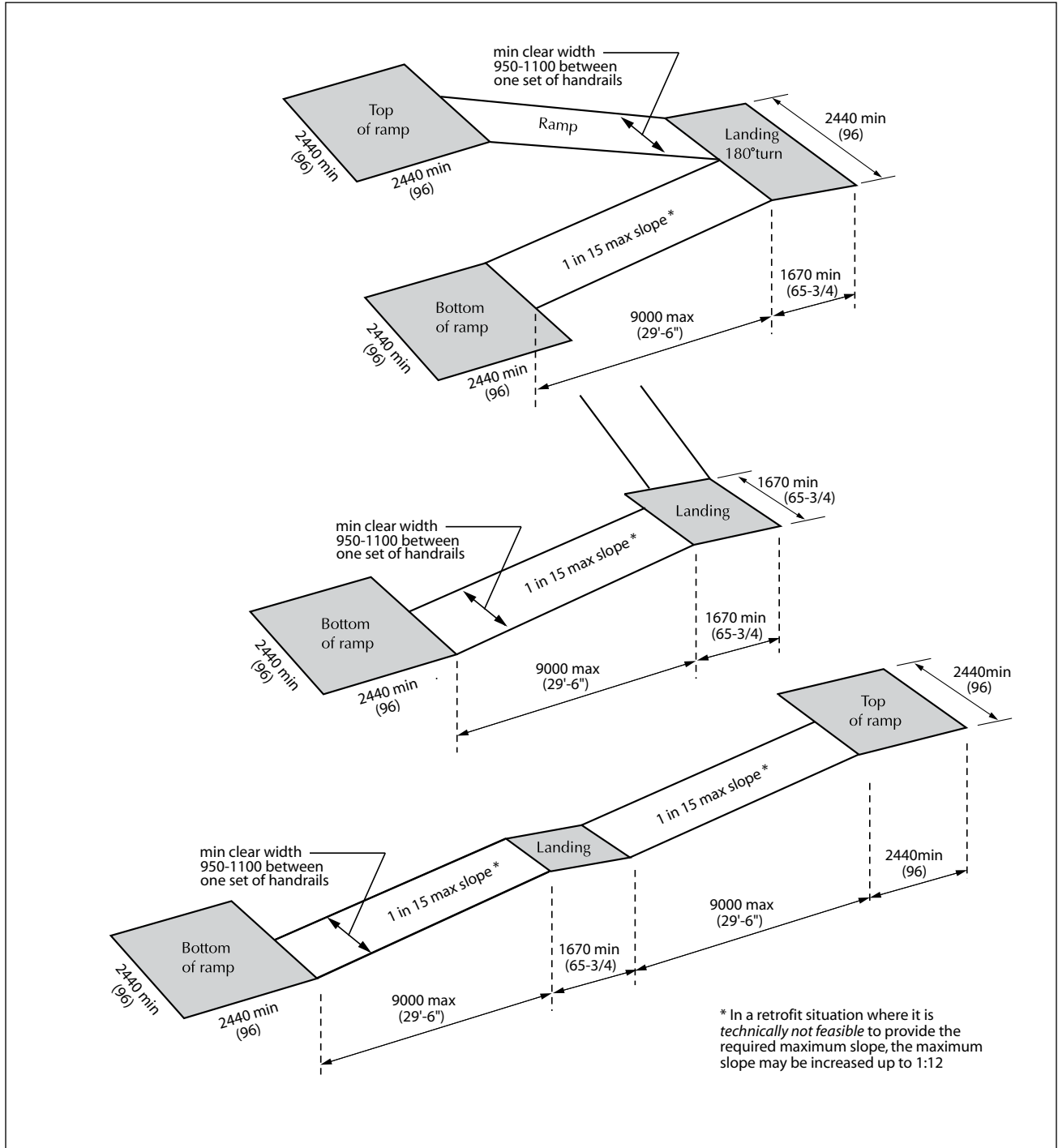

Figure 1.1.5.1 Minimum Ramp Landing Dimensions

1.1 GENERAL ACCESS AND CIRCULATION

# GENERAL STANDARDS

## 1.1.5 Ramps (continued)

Outdoor ramps and their approaches shall be designed so that water will not accumulate on walking surfaces.

Provide a dedicated area for snow piling from all exterior ramps, away from pedestrian routes.

Edges of ramps and landings shall be protected with a wall or guard on each side as per Section 1.1.7 Handrails and Guards.

Except at curb ramps, a ramp run with a rise greater than 150 mm (6 in.) shall have two sets of handrails which:

- are on both sides;
- have a width between at least one set of handrails of 950 - 1100 mm (37-1/2 in - 43-1/4 in.);
- comply with Section 1.1.7 Handrails and Guards;
- are continuous on the inside of a ramp incorporating a

change in direction U-shaped or L-shaped ramps;

- when not continuous, extend horizontally at least 300 mm (12 in.) beyond the top and bottom of the ramp and return to the wall, floor, or post;
- for the first handrail, is located between 865 mm (34 in.) and 965 mm (38 in.) from the ramp surface to the top of the handrail; and
- for the second handrail, is located 690 mm (27 in.)

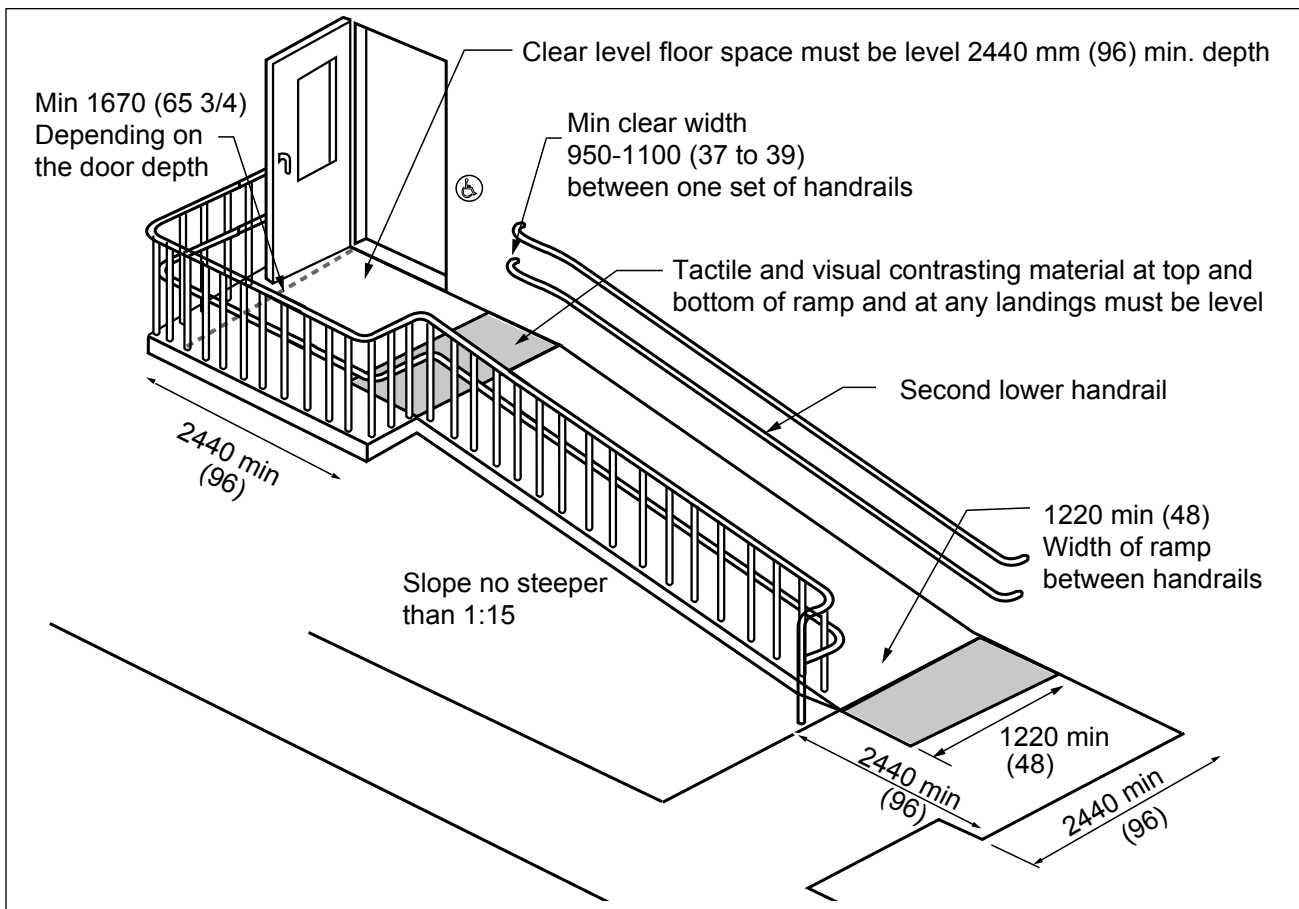

Figure 1.1.5.2 Ramp Criteria, for Maneuvering Space at Doors Refer to Figures 3.1.3.6 and 3.1.3.7

**1.1.5 Ramps (continued)**

maximum from the *ramp* surface to the top of the *handrail*.

- include spacing between the top and bottom *handrail* of 230 mm (9 in.) minimum.

**EXCEPTION:** Where a *ramp* serves as an aisleway for fixed seating, the requirements for *ramp handrails* that are continuous do not apply.

*Ramps* shall incorporate *detectable warning* surfaces in compliance with Section 1.2.6 Detectable Warning Surfaces.

**RELATED SECTIONS**

- 1.1.1 Space and Reach Requirements
- 1.1.7 Handrails and Guards
- 1.2.4 Signage
- 1.2.6 Detectable Warning Surfaces

- 2.1.1 Exterior Ground Surfaces
- 2.1.2 Exterior Lighting
- 2.1.3 Streetscape
- 2.1.5 Curb Ramps and Truncated Dome Detectable Warning Surfaces

- 3.1.1 Interior Floor Surfaces
- 3.1.3 Doors
- 3.5.3 Interior Lighting
- 3.5.4 Interior Glare and Light Sources

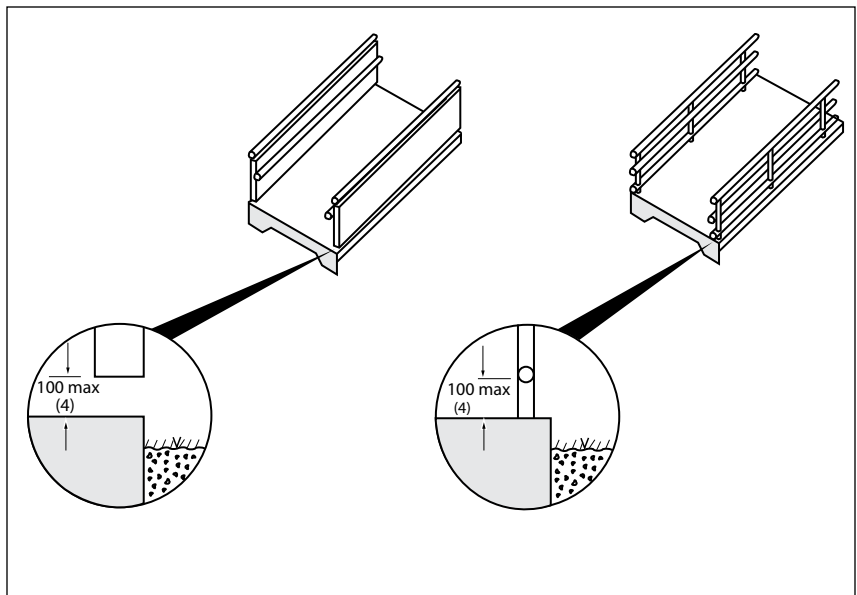

**Figure 1.1.5.3** Edge Protection at Ramps

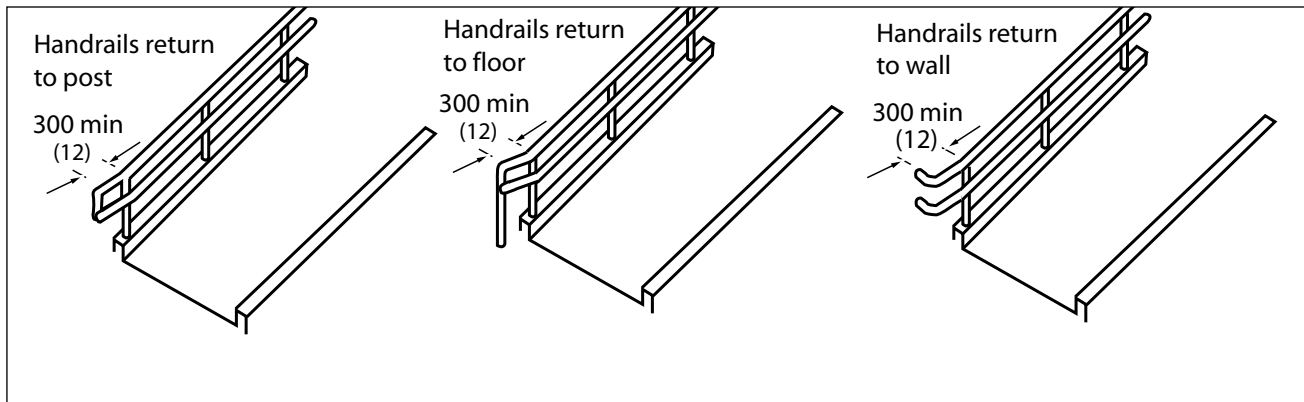

**Figure 1.1.5.4** Horizontal Handrail Extensions

**1.1 GENERAL ACCESS AND CIRCULATION**

# GENERAL STANDARDS

## 1.1.6 Stairs

### RATIONALE

Covered stairs are preferred in exterior locations. Snow accumulation at stairs should be removed completely after each snow fall.

Poorly designed stair nosings are a tripping hazard, particularly to persons with prosthetic devices or those using canes. Cues to warn individuals with vision *impairments* of an upcoming set of stairs are important, as are *colour contrasting* edges on treads. Patterned surfaces on stairs obscure edges and can be a hazard.

Dual height handrails are critical for people of various heights with varying reach ranges.

### APPLICATION

Interior and exterior stairs shall comply with this section.

Angled, concave or convex shaped stairs are very difficult to navigate and are not acceptable in a public building or space.

In a *retrofit* situation, dimensional changes to steps and landings are not required. All other design requirements must be met.

### DESIGN REQUIREMENTS

Landings shall have a length not less than 1100 mm and a width not less than the stair.

The surfaces of landings and treads shall

- have a surface that is slip resistant;

- have colour and texture contrast to demarcate the leading edge of the tread, the leading edge of the riser nosing, and the leading edge of the landing; and
- the horizontal and vertical surfaces of the stair nosing shall have a colour and texture contrasting from the remainder of the riser and tread.

A flight of stairs shall have

- uniform riser heights and tread depths;
- risers not more than 180 mm (7 in.) and not less than 125 mm (5 in.) high;
- run not less than 280 mm (11 in.) and not more than 355 mm (14 in.) deep, measured from riser to riser; and
- no open risers.

Nosings shall

- project not more than 25 mm (1 in.);
- have no abrupt undersides;
- have a curved or bevelled leading edge of the tread between 6 mm (1/4 in.) and 10 mm (3/8 in.);
- where projecting, be sloped to the riser at an angle not less than 60 degrees to the horizontal;
- be illuminated to a level of at least 100 lux (9.2 ft-candles);
- be slip-resistant; and
- have the horizontal and vertical surface of the stair nosing in 70% *colour contrast* and textured differently from the remainder of the riser and tread.

Stairs shall incorporate *detectable warning* surfaces that

- are illuminated to a level of at least 100 lux (9.2 ft-candles). Exterior lighting levels on stairs can be reduced slightly;
- are *colour contrasted* with the adjacent flooring material; and
- on landings be a min. depth of 610 mm (24) and the same width of the stair
- comply with Section 1.2.6 Detectable Warning Systems.

Stairs shall incorporate two sets of *handrails* which shall

- comply with Section 1.1.7 Handrails and Guards;
- be installed on both sides;
- for the first *handrail*, be of uniform height, located between 860 mm (33 1/2 in.) and 920 mm (36 in.) from the stair nosing;
- for the second *handrail*, be

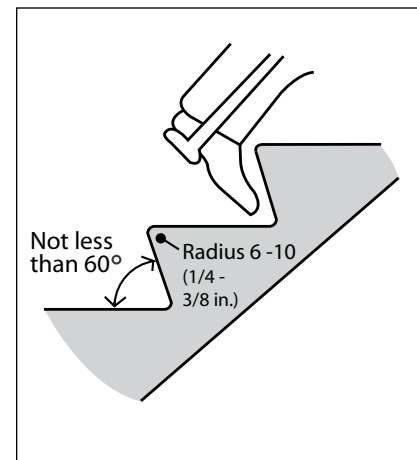
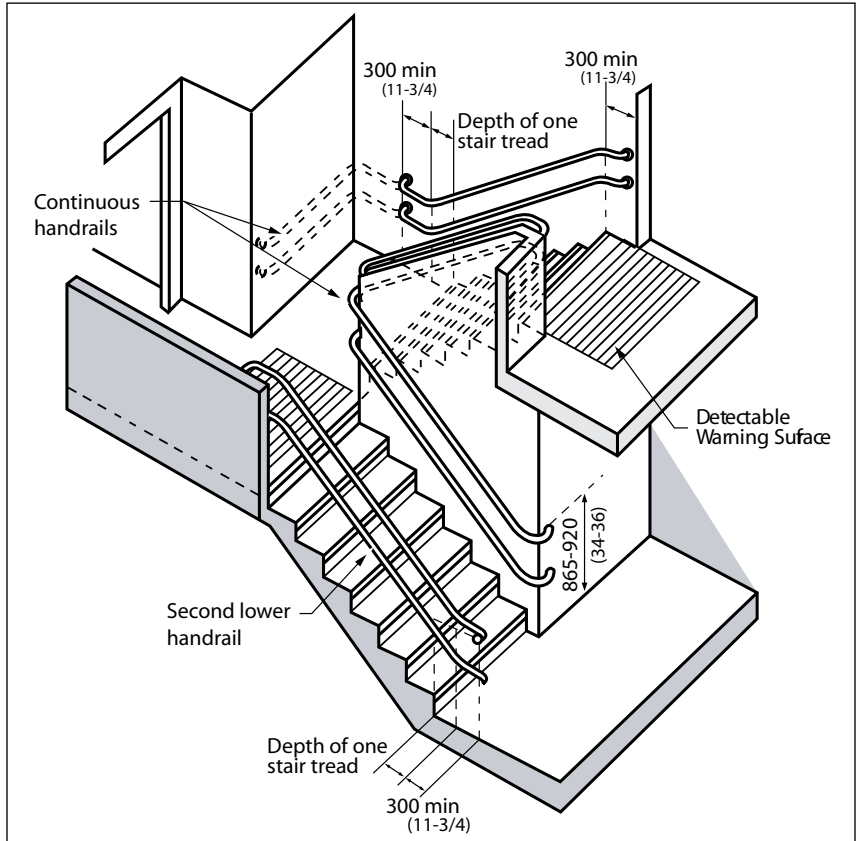

Figure 1.1.6.1 Raked Riser

**1.1.6 Stairs (continued)**

of uniform height located 690 mm (27 in.) maximum from the stair nosing

- include spacing between the two *handrails* of at least 230 mm (9 in.);
- have a continuous inside *handrail* on change of direction stairs; and
- extend at the bottom of the stairs for a distance of one tread depth beyond the first riser, then horizontally not less than 300 mm (11-3/4 in.), at a height ranging between 865 mm (34 in.) and 920 mm (36 in.) above the floor
- extend horizontally at the top of the stairs not less than 300 mm (11-3/4 in.), at a height ranging between 865 mm (34 in.) and 920 mm (36 in.) above the floor; and
- return to the wall, or post in a manner that will not obstruct pedestrian travel or create a hazard.

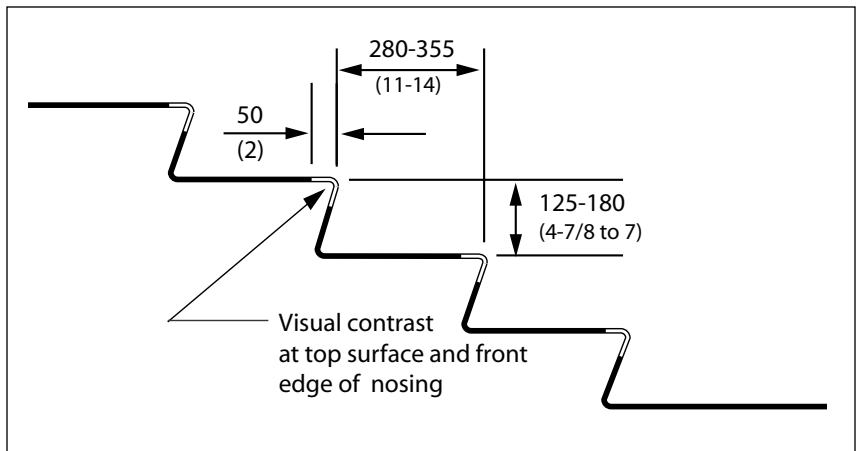

**Figure 1.1.6.2** Stair Design Criteria

Provide dedicated area for snow piling from all exterior stairs, away from pedestrian routes.

**RELATED SECTIONS**

- 1.1.7 Handrails and Guards
- 1.2.1 Texture, Finishes and Colour
- 1.2.4 Signage
- 1.2.6 Detectable Warning Surfaces
- 2.1.1 Exterior Ground Surfaces
- 2.1.2 Exterior Lighting
- 3.1.1 Interior Floor Surfaces
- 3.5.3 Interior Lighting
- 3.5.4 Interior Glare and Light Sources



**Figure 1.1.6.3** Stair Tread Criteria

**1.1 GENERAL ACCESS AND CIRCULATION**

# GENERAL STANDARDS

## 1.1.7 Handrails and Guards

### RATIONALE

In the design of *handrails*, consideration must be given to the range of hands that will grasp them. A *handrail* profile should be graspable by an adult as well as a child or a person with arthritis. The same is true for the heights of *handrails*.

Extensions of the *handrails* at the top and bottom of stairs, along with the use of a contrasting colour, provide important cues for a visually impaired individual, and provide a support to ensure a safe and stable gait before ascending or descending the stairs. A continuous *handrail* with no interruptions ensures that a handhold will not be broken.

The *clear space* between the wall and *handrail* is also essential, as it must provide a *clear* area for the hand and knuckles but must not offer *space* into which the arm may slip during a fall or stumble on the stairs.

Guards provide a protective *barrier* around an opening in a floor, balcony, or mezzanine and along *accessible* routes, paths or corridors. Guards prevent a fall to a lower level and can block entry into dangerous areas.

### APPLICATION

*Handrails* or *guards* or *cane detectable* raised curbs are required anywhere where there is a grade drop off 75 mm (3) or greater within 609 mm (24) from

any walking surface edge as per Figure 1.1.3.1

### DESIGN REQUIREMENTS

For *ramps* and stairs dual height *handrails* are required. Refer to Sections 1.1.5 Ramps and 1.1.6 Stairs.

- landing length shall not be less than 1100 mm and be the same width as the stair.

*Handrails* shall:

- have a circular section 30 mm - 43 mm (1-3/16 – 1-11/16) in diameter. Any non-circular shape, with a graspable portion that has a perimeter not less than 100 mm (4) and not more than 125 mm (5) whose largest cross-sectional dimension is not more than 45 mm (1-3/4);
- be free of any sharp or abrasive *elements*;
- have continuous gripping surfaces, without interruption by newel posts, other construction *elements*, or obstructions that can break a handhold;
- have a *clear space* between the *handrail* and the wall of
  - between 45 mm - 60 mm (1 3/4 - 2 3/8); or
  - 60 mm (2 3/8) min. where the wall has a rough surface;
- be terminated in a manner that will not obstruct pedestrian travel or create a hazard; and
- where leading to a hazardous location, optionally incorporate a textured finish for a distance of at least 600 mm

(23 1/2) from the hazard.

A recess containing a *handrail* shall extend at least 450 mm (17 3/4) above the top of the rail.

The height of a set of *handrails* shall be:

- for the first *handrail*, located between 860 mm (33 1/2) and 920 mm (36) from the *ramp* surface to the top of the *handrail*; and
- for the second *handrail*, located 690 mm (27) maximum from the *ramp* surface to the top of the *handrail*.
- spaced a minimum of 230 mm (9) between the top and bottom *handrail*.

*Handrails* and their supports shall be designed and constructed to withstand the loading values obtained from the non concurrent application of:

- a concentrated load of not less than 0.9 kN (200 lb.) applied at any point and in any direction; and
- a uniform load of not less than 0.7 kN/m (47 lb./ft.) applied in any direction to the *handrail*.

*Handrails* shall incorporate a pronounced *colour contrast* of at least 30% to differentiate them from the surrounding environment.

Glass partitions shall not be used as *handrails* unless they are capped and have visual markers interrupting the glass that are colour contrasting to the sur-



**1.1.7 Handrails and Guards (continued)**

rounding surfaces (refer to 3.1.4).

Where a *guard* is provided, it shall:

- be a minimum of 150 mm (5-3/4 in.) high in order to be cane detectable and to act as a safeguard for wheelchair users;
- comply with the requirements of the *MBC*.

**RELATED SECTIONS**

- 1.1.1 Space and Reach Requirements
- 1.1.3 Accessible Routes, Paths and Corridors
- 1.1.5 Ramps
- 1.1.6 Stairs
- 1.2.1 Texture, Finishes and colour

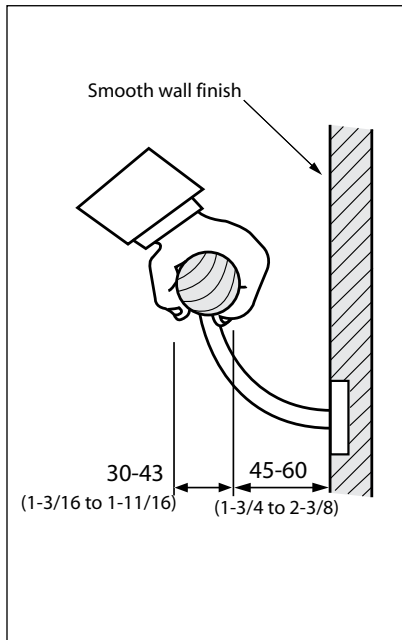

**Figure 1.1.7.1 Handrail at Smooth Wall**

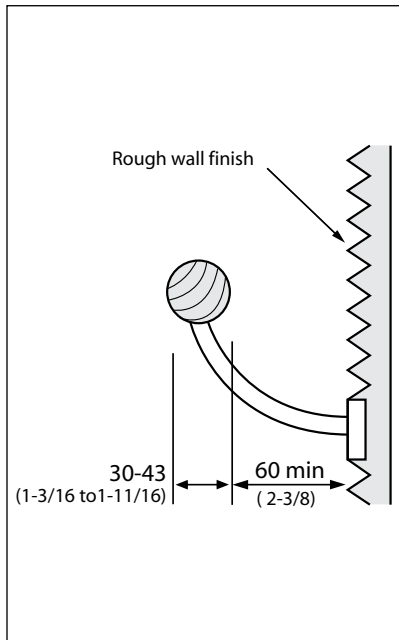

**Figure 1.1.7.2 Handrail at Rough Wall**

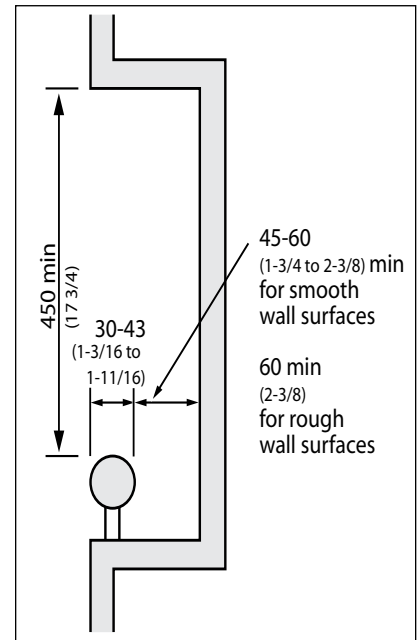

**Figure 1.1.7.3 Handrail in Recess**

Note: Two heights of handrails are required as Sections 1.1.5 and 1.1.6.

**1.1 GENERAL ACCESS AND CIRCULATION**

# GENERAL STANDARDS

## 1.1.8 Accessible Routes: Maintenance

### RATIONALE

Minimum *clear* widths should be maintained for all paths of travel. When temporary *barriers* are erected around a construction *site* a clear alternate path of travel is warranted.

### DESIGN REQUIREMENTS

Street or hallway construction can pose a hazard for persons with disabilities, particularly those who are blind or have some level of vision impairment. Extra precautions shall be used to ensure construction barricades do not pose additional hazards.

Where temporary construction interrupts an *accessible* route, path or corridor the minimum unobstructed width requirements for pedestrian travel must remain. A minimum of 1100 mm (43-1/4 in.) for interior routes and 1220 mm (48 in.) for exterior routes is required.

Alternative *accessible* safe crossings shall be provided where existing construction works obstruct *curb ramps* at intersections.

Where construction barricades are located along *accessible* routes, paths and corridors they must be cane detectable. An orange construction cone placed beneath barricades shall suffice. Refer to Section 1.1.2 Protruding and Overhead Objects for cane detection requirements.

All detectable warning surfaces must be kept clear of debris and cleaned such that their level of conspicuity is maintained.

In interior spaces, ensure waste receptacles or other movable items are not placed within the clear space at any operable device (doors, door operators, hand dryers, etc.).

### 1.2.1 Texture, Finishes and Colour

#### RATIONALE

The ability of people to navigate an environment comfortably and easily can be promoted through the strategic use of colour and texture.

Heavy or distinct patterns on walking paths, walls or floors, should be avoided. These can be disorienting and add visual confusion to an environment for persons with perceptual difficulties and low vision. Simple, repetitive, non-directional patterns that feature monochromatic or low colour contrast are preferred. Changes in material or texture should not necessitate an excessive change in level.

Generally, for seniors and persons with low vision, colours in the warm end of the spectrum (yellow, orange, bright red, etc.) are easier to recognize as a delineator than those at the cool end of the spectrum (blue, green).

The *conspicuity* of a colour in addition to the *light reflectance* value are the critical factors needed to determine *colour contrast*.

#### APPLICATION

Texture and colour systems shall be used to enhance accessibility and shall comply with this section.

Colour and texture needs are very different for indoor and outdoor applications. Outdoor spaces require more consistent colour

and texture due to weather, lighting, and maintenance. Indoor conditions have more consistent lighting therefore choices of colour, texture and material are more flexible.

#### DESIGN REQUIREMENTS

Colour schemes shall incorporate a pronounced *colour contrast*, to differentiate boundaries of objects, distinguish objects from their background, and to generally enhance spatial orientation. Colour and texture are also used to define edges of an *accessible route*.

Signs shall incorporate pronounced glare-free *colour contrast*. A minimum colour/brightness contrast of 70% light reflectance is required. For signs, the most visible colours are white/buff or yellow on a black, charcoal or other dark background, such as brown, dark blue, dark green or purple. Black lettering on white is also acceptable, although less readable than the reverse. Remember that context is important to consider (i.e. dark blue against the night sky disappears).

Unacceptable background colours are light grey and pastel colours. Red lettering on a black background is also unacceptable.

*Colour contrast* shall be used as a safety measure to define edges or boundaries of objects and *accessible routes* (e.g., stair nosings, doors, *handrails*, etc.). Colour or tone shall be used to visually define the boundaries of

a room (i.e., where the wall meets the floor). Baseboards in monochromatic environments shall be highly contrasting with the wall and floor colours, to provide boundary definition. Carpet can act as contrast provided it meets the colour contrast requirement.

Colour shall be used consistently to visually identify distinctive objects (e.g., exit doors).

Either bright colours or a highly contrasting tone shall be used to assist with *wayfinding*. (e.g. If used as part of a *signage* band located on walls at eye level, this band is easier to follow than monolithic wall colouring, and can be the visual cue for other essential signs.)

End walls or return walls in long corridors shall be visually defined using highly contrasting colours or tone to enhance a change of direction or the end of the *space*.

*Detectable warning* surfaces shall be used to define potential hazards and to assist in way finding.

All textured surfaces used as *detectable warning* devices shall be *canedetectable* and clearly differentiated from the surrounding ground surfaces.

Suitable interior textures include raised domes, dots or squares in/on terrazzo or other stone like materials, tile or rubber surfacing. *Truncated domes* are not required at interior spaces. An alternative is applied carborendum or other non-slip strips or other stone-like

# GENERAL STANDARDS

materials.

Suitable exterior detectable textures include raised yellow tactile domes. Directional raised bands can be used as directional guidance. Textured pavers or natural ground such as grass or hard packed limestone or shale can be used to delineate a path of travel.

Supplementary textural cues shall also be provided (e.g., by using different floor textures or materials, in major and minor routes).

Clearly defined boundaries of materials like carpeting or floor tiles shall enhance *wayfinding* by defining such as the junction between walls and floors, doorway recesses and corridor intersections.

Throughout any one *site*, the same texture shall be consistently used to identify the same type of hazard.

## RELATED SECTIONS

All relevant parts of Sections 1.0 General Design Standards, 2.0 Exterior Design Standards and 3.0 Interior Design Standards.

**1.2.2 Acoustics**

**RATIONALE**

The acoustic environment of public *buildings* and *spaces* should accommodate the unique needs of persons who are hard of hearing and who need to differentiate essential sounds from general background noise.

The acoustic characteristics of a *space* help to define it. The effect of movement on the sound in a *space* provides information that can be very useful to persons who have cognitive or vision *impairments* - although it may go unnoticed by other people.

Floor and wall coverings can be sound-reflective or sound absorbent. The finishes used changes the acoustical characteristics of the *space*. It is important that acoustical cues are clearly audible, and are not masked or garbled by other sounds (such as fans, elevator doors, *street* traffic, peoples voices, etc.). A person can use reflective sound to determine the size of the room, the presence of corridors or other circulation routes, the proximity of walls and other *elements* (see Figure 1.2.2.1).

Within a built *space*, specific sounds can provide cues about the location of special features, such as an elevator. Avoid echo reflection and ambient sound (sound glare) as it interferes with the process of locating auditory cues.

The sound transmissions of different areas can be used as an orientation cue and help to navigate a *space*.

**APPLICATION**

The acoustical environment of *facilities* used by the general public, clients, customers and employees shall comply with this section.

**DESIGN REQUIREMENTS**

At *accessible routes* in large *facilities* where *wayfinding* is problematic, the sound transmission and reflection characteristics of finish materials shall aurally differentiate major and secondary paths of travel.

Floor finishes, wall surfaces and ceilings shall be selected so that occasional noise is not unduly amplified. (e.g., Hard surfaces such as marble or terrazzo will allow each foot step to be heard by persons who are vision impaired, but may add another level of confusion for persons who are hearing impaired.)

Ceiling shapes shall be designed so that echoes do not occur, unless an alternate acoustical treatment is incorporated. (Note: domed shapes tend to distort sound.)

In a narrow space sound absorbing materials must be placed on the walls (Figure 1.2.2.1).

Diffusing elements placed on the curves of a circular room helps disperse and absorb sound and eliminate echoes (Figure 1.2.2.2)..

In *meeting rooms* and *assembly*

*areas* where the spoken word is key to comprehending the proceedings, all unnecessary background noise (e.g., from fans or other mechanical equipment, air diffusers, etc.) shall be dampened and/or the room shall include adequate sound insulation.

**RELATED SECTIONS**

- 1.2.3 Public Address Systems
- 1.2.4 Signs
- 3.2.1 Information, Reception and Service Counters
- 3.2.3 Office, Work Areas and Meeting Rooms
- 3.4.2 Assistive Listening Systems

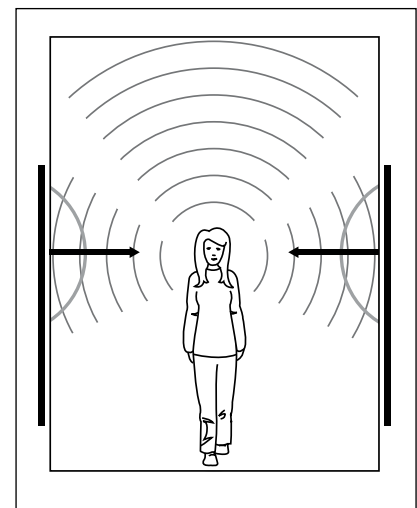

**Figure 1.2.2.1** Narrow Spaces

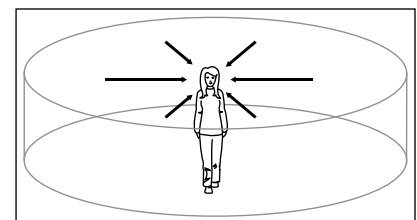

**Figure 1.2.2.2** Circular Spaces

# GENERAL STANDARDS

## 1.2.3 Public Address Systems

### RATIONALE

Public address systems should be designed to best accommodate all users, especially those who may be hard of hearing. They should be easy to hear above the ambient background noise of the environment and there should be no distortion or feedback. Background noise should be minimized.

Visual equivalents such as reader boards should be made available for individuals who may not hear an audible public address system.

### APPLICATION

Public address systems shall be tied into a visual alert system.

Public address systems shall comply with this section.

### DESIGN REQUIREMENTS

Public address speakers shall be mounted above head level, and provide effective sound coverage in required areas, such as corridors, assembly and *meeting room* areas, recreational and entertainment *facilities*, educational *facilities*, and *common use* areas in institutional settings (i.e. washrooms)

Public address systems shall be zoned so that information can be directed to key locations only, minimizing background noise in other areas and shall be tied into a visual alert system.

Public address and call systems shall be capable of being zoned to key areas, rather than blanketing all areas of a *facility* at all times.

All-point call systems shall only be utilized for exiting, fire and emergency information.

Paging systems for staff and other key persons shall be discreet and low volume, and sound only at those devices or locations where such persons might expect to be located.

Audible and visual descriptions shall not be turned off during operational hours in any facility.

### RELATED SECTIONS

- 1.1.2 Protruding and Overhead Objects
- 1.2.2 Acoustics
- 3.1.8 Emergency Exits, Fire Evacuation and Areas of Rescue Assistance

1.2.4 Signage

**RATIONALE**

Interior and exterior signs provide essential information to everyone. *Signage* should be simple, uncluttered and incorporate plain language and easily understood symbols and/or diagrams. Consistent placement of signage enhances usability for everyone. The use of graphic symbols is helpful for children, those with a limited literacy level, or for those who speak a different language.

Sharp contrasts in colour make *signage* easier for anyone to read, particularly someone with a vision *impairment*. The intent of the symbol must be evident, culturally universal and not counter intuitive. To enhance readability, raised *tactile* lettering should incorporate edges that are slightly smoothed. The use of the Canadian Institute of the Blind “Clear Print Guidelines” is recommended to assist with colour contrast.

Audible signs (infrared and digital) that are readable by visually impaired persons using a receiving device may be the sole orientation aid across *open spaces*. Consideration should be given to including wire drops for future installation.

Taking into account the level of complexity of some interpretive signs the character size requirements is lower (see Table 1.2.4.1). As an alternative format, having the provision of auditory commentary of the information provides equitable use for people who do not read print.

Information should be minimized and clearly presented using sans-serif font. Never place print over background pictures.

A proliferation of signage must be avoided as it creates visual noise resulting in confusion and misunderstanding.

Note: Interpretive signs should always be mounted in accordance with Figure 1.2.5.1.

Running reader boards must be timed in a manner that is slow enough for slower readers.

Note: Traffic control devices, including traffic signs in the public *right-of-way*, must be in accordance with the Manual of Traffic Control Devices for Canada (MTCDC) or otherwise approved

by Manitoba Regulation 264/88 Traffic Control Devices.

**APPLICATION**

*Signage* shall comply with this section. That includes signs that provide direction to, or information about, functional *spaces*.

Signs that designate permanent rooms or *spaces* shall be wall-mounted on the latch side of the entrance where possible and include *tactile* characters, Grade 1 Braille and numbers. In complex situations colour coding can help with wayfinding.

Where closures, temporary outages, etc. occur, temporary signage placed proximate to that location is required.

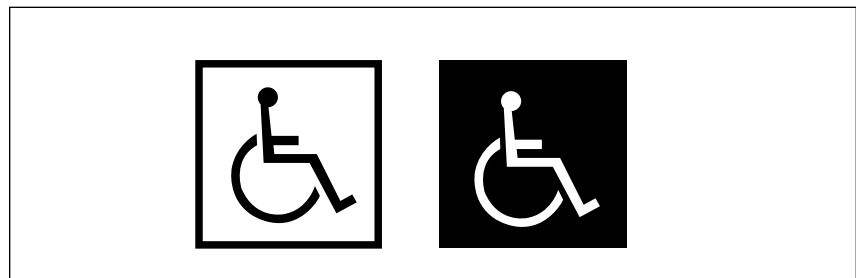

Figure 1.2.4.1 Colour Contrast on Signs / International Symbol of Access

Minimum character height, mm	Maximum viewing distance, mm
25 mm (1 in.)	750 mm (29 1/2 in.)
50 mm (2 in.)	1.5 m (5 ft.)
75 mm (3 in.)	2.3 m (8 ft.)
100 mm (4 in.)	2.5 m (8 ft. 2 in.)
150 mm (6 in.)	4.6 m (15 ft.)
200 mm (8 in.)	6.0 m (19 ft. 8 in.)

Table 1.2.4.2 Character Height on Room Identifier Signs

# GENERAL STANDARDS

## 1.2.4 Signage (continued)

*Elements and spaces of accessible facilities* that shall be identified by the International Symbol of Accessibility are

- parking *spaces*, designated as reserved for individuals with *disabilities*;
- *accessible* passenger loading zones;
- *accessible entrances* when included with *entrances* that are not accessible (inaccessible *entrances* shall have directional *signage* to indicate the route to the nearest *accessible entrance*);
- *accessible toilet facilities*, including single-use portable units, when not all are *accessible*;
- *accessible* telephones;
- *accessible* elevators and other elevating devices;
- *accessible means of egress*; and
- *areas of rescue assistance*.

- have a width-to-height ratio between 3:5 and 1:1; and
- have a stroke-width-to-height ratio between 1:5 and 1:10.

Character height dimensions for viewing distance shall comply with Table 1.2.4.2.

Characters, symbols and backgrounds of signs shall have an eggshell, matte or other glare-free finish.

Characters and symbols shall *colour contrast* with their background. A minimum 70% contrast should be attained based on the following calculation:

$$\text{Contrast} = \{(B1 - B2) / B1\} \times 100$$

Note: Refer to CNIB Guide to Effective Colour Contrast

Signs must be context sensitive i.e. navy or dark grey on an exterior non-lit sign will disappear at night.

Where signs are required to be *tactile*, letters and numerals shall be

- raised at least 0.8 mm (1/32 in.), not sharply edged;
- be between 16 mm (5/8 in.) and 50 mm (2 in.) high; and
- be a sans serif font, accompanied by Grade 1 uncontracted Braille.

Pictograms shall be accompanied by an equivalent visual and *tactile* verbal description, placed directly below the pictogram. The border dimension of the pictogram shall be 150 mm (6 in.) minimum in height and raised 0.8 mm- 1.5 mm from the background surface.

Where permanent identification is provided for rooms and *spaces*, signs shall be installed on the wall adjacent to the latch side of the door 150 mm (6 inches) from the door jam, located with their centre line at a height 1350 mm (53 inches). Where permissible, signs should be consistently located.

Where there is no wall *space* to the latch side of the door, including at double-leaf doors, signs shall be placed on the nearest adjacent wall, in a location that is easy to see, reach and touch.

Signs shall be *colour contrasted* to the surface they are mounted upon. Framing the sign with a boarder matching the pictogram will enhance the colour contrast. The boarder creates a 3D effect when placed against a colour contrasted surface or wall.

In crowded areas, signs shall be placed above head-level to increase their visibility. Overhead signs are not required to be *tac-*

### DESIGN REQUIREMENTS

Letters and numbers on signs shall

- not be stylized or italicized
- be sans serif fonts;
- have Arabic numbers;

Minimum character height	Signage text type
8 mm (1/3 in.)	captions
13 mm (1/2 in.)	body text
14 - 17 mm (5/8 - 2/3 in.)	subtitles
21 - 26 mm (13/16 - 1 in.)	titles
once the viewer is 1 meter (39 in.) from the sign, the font size will increase proportionally and double in size.	

**Table 1.2.4.1** Character Height on Interpretive and *Wayfinding* Signage



**1.2.4 Signage (continued)**

tile or Brailled.

Temporary signage such as A-frame sandwich boards shall not be placed in the accessible route.

Temporary signage placed proximate to the location that provides information regarding closures, temporary outages, etc. are required.

The minimum level of illumination on signs shall be 200 lux (18.4 ft-candles).

All signs in the Riel Community area and Central office of the City of Winnipeg shall be bilingual in English and French.



**Figure 1.2.4.3** Pictograms  
(Note: Must incorporate equivalent verbal description)

**Character Height on Public Wayfinding Signs and Maps**

Wayfinding sign and maps are tools intended for people of all ages and abilities to navigate through the city, regardless of their level of familiarity with the city. Requirements under Section 1.2.5 apply.

Use of clear language and pictures of key features used on maps is imperative for those who may be unfamiliar with their surroundings. These key features should be tactile to insure use by individuals with vision impairments.

**RELATED SECTIONS**

All relevant parts of Sections 1.0 General Design Standards, 2.0 Exterior Design Standards and 3.0 Interior Design Standards.

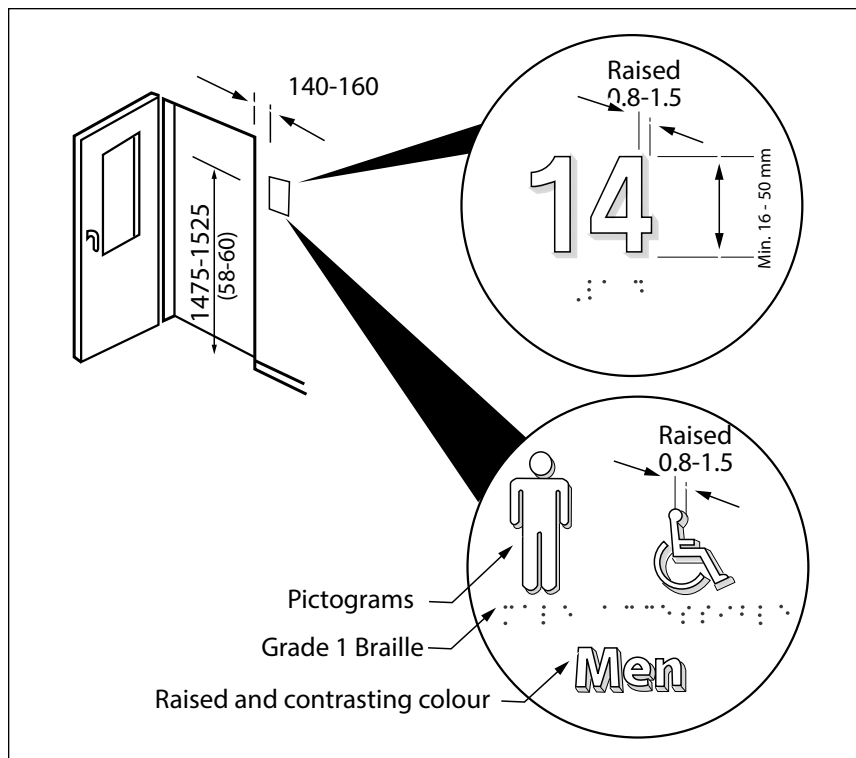

**Figure 1.2.4.4** Tactile Lettering

# GENERAL STANDARDS

## 1.2.5 Information Systems

### RATIONALE

Information should be *accessible* to all facility users. Where universally *accessible* formats are technically not feasible alternate formats should be available. Video display terminals may present particular difficulties for persons with vision *impairments*. Alternate technology or audio interfaces are required. To ensure that a person using a wheelchair can access an information terminal, consideration should be given to the lower vantage point and reach ranges.

*Wayfinding* maps with tactile features are beneficial to an independent traveller who is vision impaired.

### APPLICATION

Information systems, such as display kiosks, video display terminals and interpretive/informational panels shall comply with this section.

### DESIGN REQUIREMENTS

Where information is provided by video display terminals the same information shall be provided in an alternative format, such as audio, Braille and large-text print. Refer to the Canadian National Institute of the Blind "Clear Print Guidelines" for further detail and/or Table 1.2.5.1.

Information systems designed for direct access by the public, such as a touch-screen video display, shall have keyboard or keypads mounted at a height suitable for

use by persons using wheelchairs or scooters as per Section 3.5.1 Controls and Operating Mechanisms. Essential information shall be displayed in large text on a *colour contrasting* background. Detailed information should also be available in other formats, such as audiotape or large-text print.

Push buttons or other controls for accessing public information systems should be clearly identifiable by colour and/or tone from the background colour, and should include raised numbers, numerals or symbols for easy identification by persons who are visually impaired. *Tactile* identification shall comply with Section 1.2.1 Texture, Finishes and Colour.

Exhibits that include important artefacts, labels and graphics, shall be placed 1000 - 1200 mm (39-3/8 - 47 in.) from the floor. If

exhibits are behind glass, a reasonable, accessible facsimile of the artefact shall be displayed within arms-reach of that artefact in accordance with Section 1.2.1. Touch screens can be made accessible if they include a tactile or audible component that allows for independent use.

Labels and descriptive *signage* shall be inclined from horizontal for easier reading.

Inclined informational/interpretive panels that can not be read from 750 mm (65 in.) away shall allow 660 mm (26 in.) of knee clearance from the ground and at least 480 mm (19 in.) depth, see Figure 1.2.5.1. If displays are legible from 750 mm (65 in.) or further, less clearance is permitted to a minimum height of 220 mm (9 in.) for toe kick clearance.

No part of the sign shall encroach

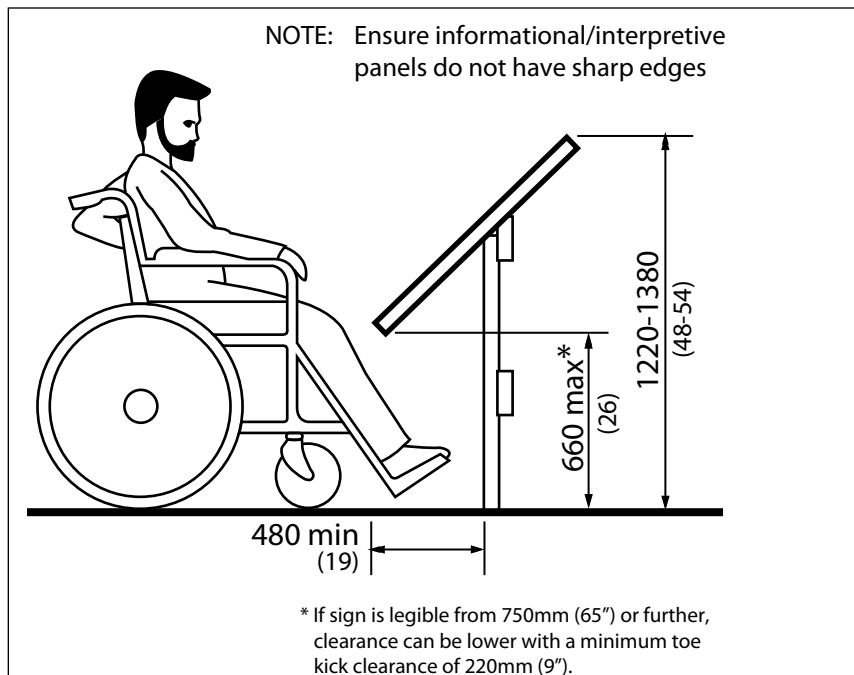

## 1.2 GENERAL INFORMATION AND COMMUNICATION SYSTEMS

**1.2.5 Information Systems (continued)**

on the path of travel. If encroachment is unavoidable, *cane-detection* through colour and texture change shall be provided on the ground.

A minimum 1500 mm x 1500 mm (54 in. x 54 in.) *clear space* directly in front of the sign is required for its approach and use. The clear space must be of a hard surface material.

**RELATED SECTIONS**

- 1.2.1 Texture, Finishes and Colour
- 1.2.2 Acoustics
- 1.2.3 Public Address Systems
- 1.2.4 Signage
- 2.1.3 Streetscape
- 3.5.1 Controls and Operating Mechanisms

Background Surface	Sign Background	Colour of Lettering
Light brick or light stone	Dark (black preferred)	White/yellow
Whitewashed wall	Dark (black preferred)	White/yellow
Red brick or dark stone	White	Black, dark green or dark blue
Green Vegetation	White	Black, dark green or dark blue

**Table 1.2.5.1** CNIB Guide to Effective Colour Contrast

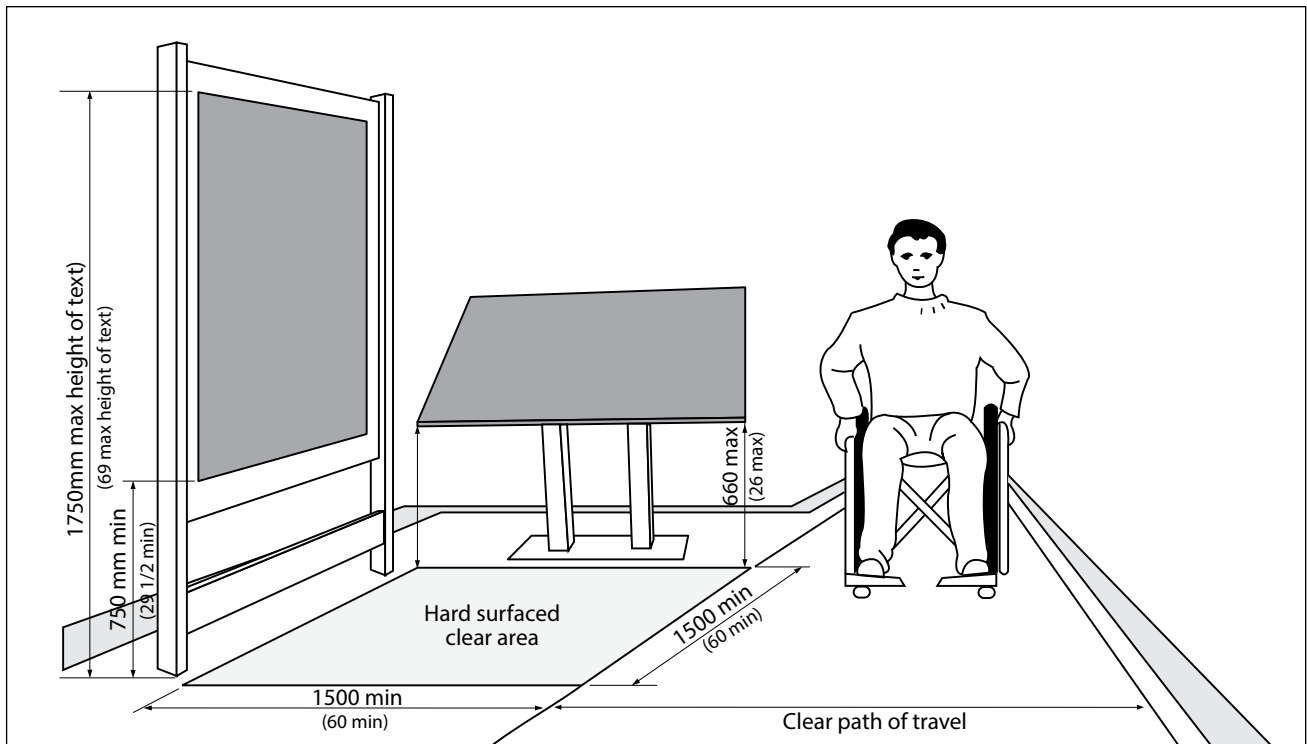

**Figure 1.2.5.2** Informational/Interpretive Information Systems

# GENERAL STANDARDS

## 1.2.6 Detectable Warning Systems

### RATIONALE

*Detectable warning surfaces* provide important navigation cues for persons with a vision *impairment*. These surfaces alert all pedestrians to potential hazards, such as changes in level, vehicular intersections, crosswalks or stairs. Suitable surfaces include a change in texture and high *colour contrast* but should not present a tripping hazard. *Detectable warning surfaces* should be used consistently throughout a *facility*.

### APPLICATION

*Detectable warnings* at *curb ramps* on collector and regional intersections, *walkways*, landings on exterior *ramps* and stairs and raised platforms such as the bus rapid transit stations shall comply with this section.

Platforms such as stages and seating walls that are in the accessible route must include detectable warnings that are context sensitive. Interior stairs, landings, and ramps shall include detectable warnings that are context sensitive but still provide visual and textural contrast to the user.

### DESIGN REQUIREMENTS

All textured surfaces used as *detectable warning surfaces* shall be *cane-detectable* and clearly differentiated from the surrounding ground or floor surfaces. Refer to Section 1.2.1 Texture, Finishes and Colour (Figure 1.2.6.4).

*Detectable warning surfaces* shall contrast visually with adjoining surfaces by a minimum of 70% *colour contrast*, either light on dark or dark on light. Exterior *detectable warning surfaces* at roadways and transit ways installed in concrete shall be yellow only. Detectable warning surface shall be kept clean such that their conspicuity is maintained.

*Detectable warning surfaces* at stairs shall:

- be provided at the top of the stairs and at landings; and
- extend the full width of the stair for a depth of at least 610 mm (24 in.) commencing one tread depth back from the stair.

*Detectable warning surfaces* at ramps shall:

- be provided at the top, bottom and each landing of each ramp;

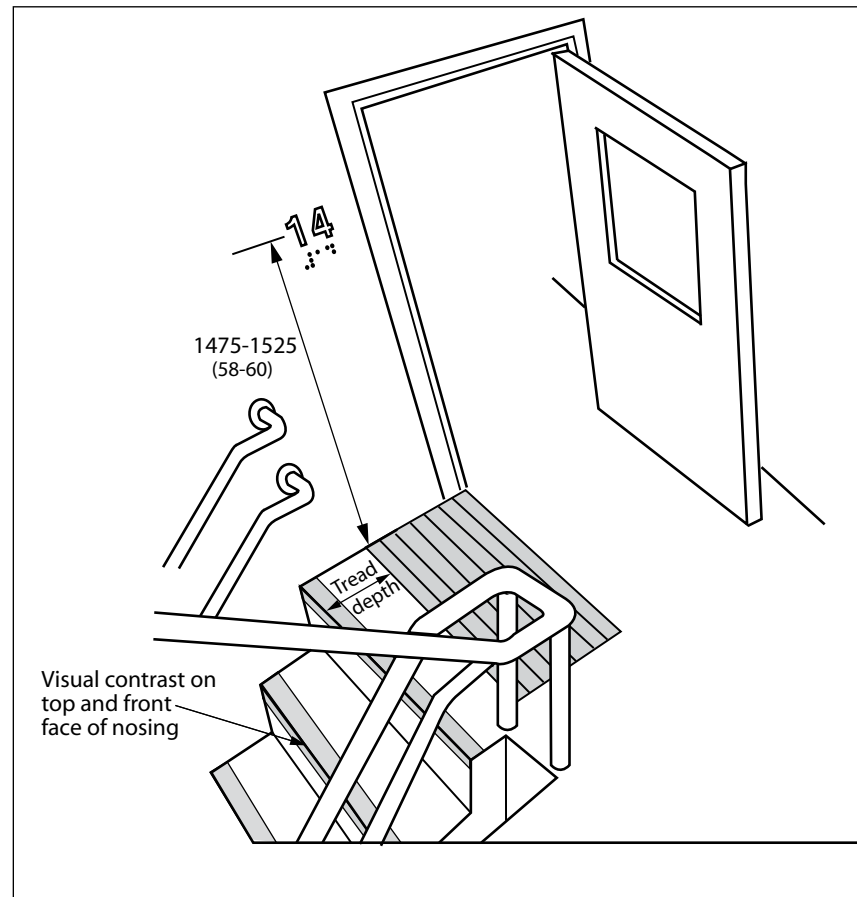

Figure 1.2.6.1 Detectable Warnings at Stairs

1.2.6 Detectable Warning Systems (continued)

- extend the full width of the ramp for a depth of at least 610 mm (24 in.); and
- not extend into the door swing area.

Detectable warning surfaces at elevated platforms shall:

- be composed of truncated domes
- with a height of  $5 \pm 1$  mm;
- with a base diameter of 23 mm ; and
- be organized in a regular pattern with spacing of 60 mm minimum on centre;
- be slip resistant when dry or wet; and
- contrast visually with adjoining surfaces

Note: For installation configurations for detectable warning surfaces at curb ramps refer to Section 2.1.5 Curb Ramps and Truncated Dome Detectable Warning Surfaces.

RELATED SECTIONS

- 1.1.2 Protruding and Overhead Objects
- 1.1.3 Accessible Routes, Paths and Corridors
- 1.1.5 Ramps
- 1.1.6 Stairs
- 1.2.1 Texture, Finishes and Colour
- 1.3.1 Drinking Fountains
- 1.4.1 Water Facilities...
- 2.1.3 Streetscape
- 2.1.5 Curb Ramps and Truncated Dome Detectable Warning Surfaces
- 2.3.1 Parking
- 3.1.7 Escalators
- 3.2.3 Passenger Loading

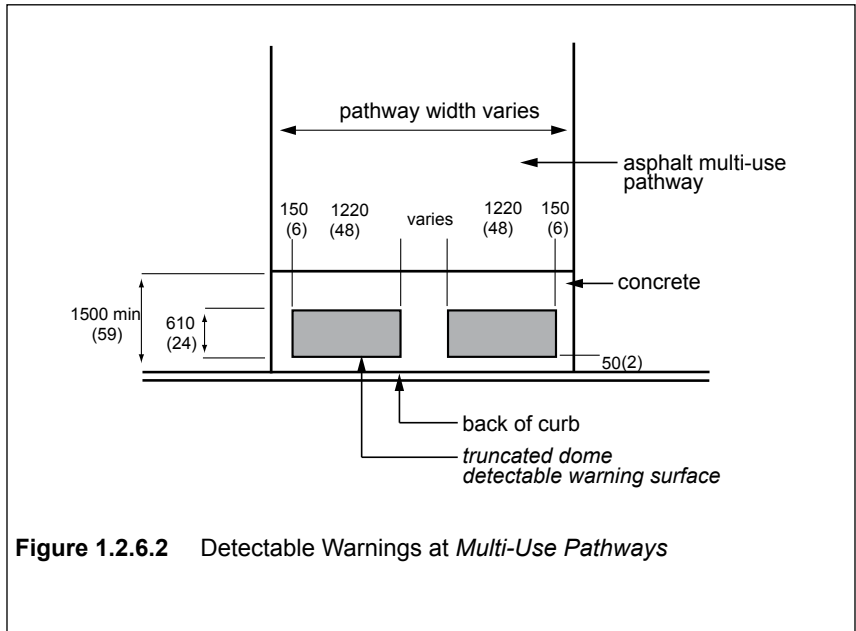

Figure 1.2.6.2 Detectable Warnings at Multi-Use Pathways

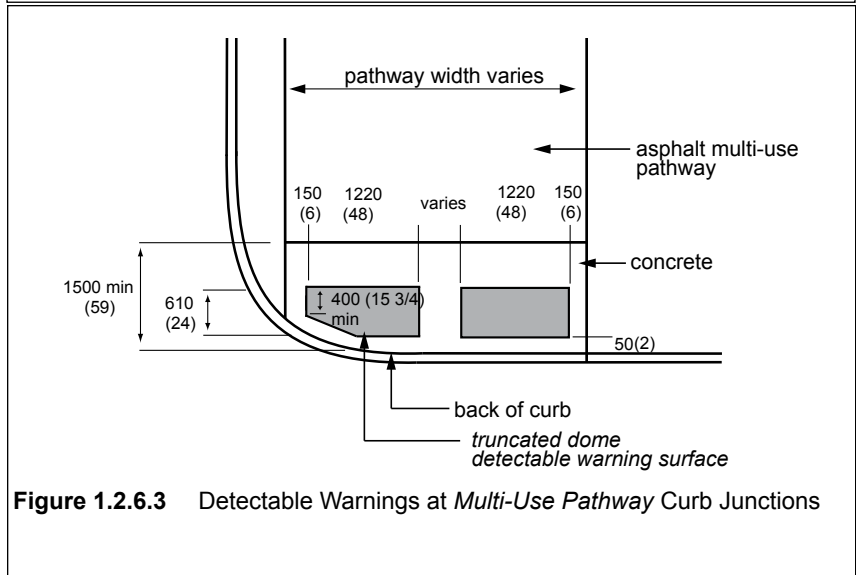

Figure 1.2.6.3 Detectable Warnings at Multi-Use Pathway Curb Junctions

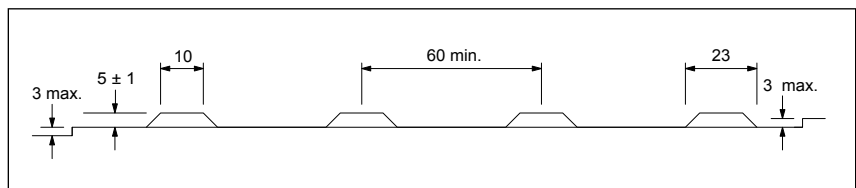

Figure 1.2.6.4 Detectable Warning Surface - Truncated Dome Elevation

1.2 GENERAL INFORMATION AND COMMUNICATION SYSTEMS

# GENERAL STANDARDS

## 1.3.1 Drinking Fountains and Bottle Fillers

### RATIONALE

Planning for the design of drinking fountains with or without bottle fillers, should consider the limited height of children or persons using a wheelchair. In the same respect, there may be individuals who have difficulty bending who would require a higher fountain. The operating system should account for limited hand strength or dexterity. The placement of the fountain is also important. Fountains should be recessed to avoid protruding into the path of travel, especially if they are wall mounted above the height of *cane-detection*.

### APPLICATION

Where only one drinking fountain is provided on a floor, it shall incorporate components that are *accessible* to individuals who use wheelchairs in accordance with this section, as well as components that are *accessible* to persons who have difficulty stooping or bending.

Where more than one drinking fountain or water cooler is provided on a floor, at least 50% shall comply with this section.

This section applies to the operating mechanisms of a bottle filler where incorporated.

### DESIGN REQUIREMENTS

*Accessible* drinking fountains shall

- be located on an *accessible route* complying with 1.1.3;
- have a spout located near the front of the unit between 760 mm (30 in.) and 900 mm (35 in.) above the floor or ground surface;
- have a spout that directs the water flow in a trajectory that is parallel or nearly parallel to the front of the unit;
- have a spout that provides a water flow at least 100 mm (4 in.) high; and
- be equipped with controls that are located on the front of the unit, or on both sides of the unit, easily operated from a wheelchair, using one hand, with a force of not more than 22 N (4.9 lb.), or be automatically operable.

Cantilevered drinking fountains shall

- have a *clear space* of at least 900 mm (35-1/2 in.) by 1500 mm (59 in.) see Figure 1.3.1.2;
- have a knee *space* between the bottom of the apron and the floor or ground of at least 900 mm (35-1/2 in.) wide, 200 mm (7-7/8 in.) deep and 685 mm (27 in.) high. See Figure 1.3.1.3;
- have a toe *space* not less than 900 mm (35-1/2 in.) wide, 230 mm (9 in.) deep, and 230 mm (9 in.) high; and
- be recessed or otherwise located out of the circulation route.

Cantilevered drinking fountains

that project into an *accessible route* shall be identified by a *detectable warning* surface of at least 300 mm (11-3/4 in.) around the object, installed flush with the walkway surface in accordance with Section 1.1.2..

Fountains not having a knee *space* shall have a *clear space* at least 1500 mm (59 in.) wide by 900 mm (35-1/2 in.) deep in front of the unit. See Figure 1.3.1.1. Flooring in front of the drinking fountain shall be coloured and textured differently from the surrounding surfacing in accordance with Section 1.2.1.

### RELATED SECTIONS

- 1.1.1 Space and Reach Requirements
- 1.1.2 Protruding and Overhead Objects
- 1.1.3 Accessible Routes, Paths and Corridors
- 1.2.1 Texture, Finishes and Colour
- 2.1.1 Exterior Ground Surfaces
- 2.1.3 Streetscape
- 3.1.1 Interior Floor Surfaces

1.3.1 Drinking Fountains and Bottle Fillers (continued)

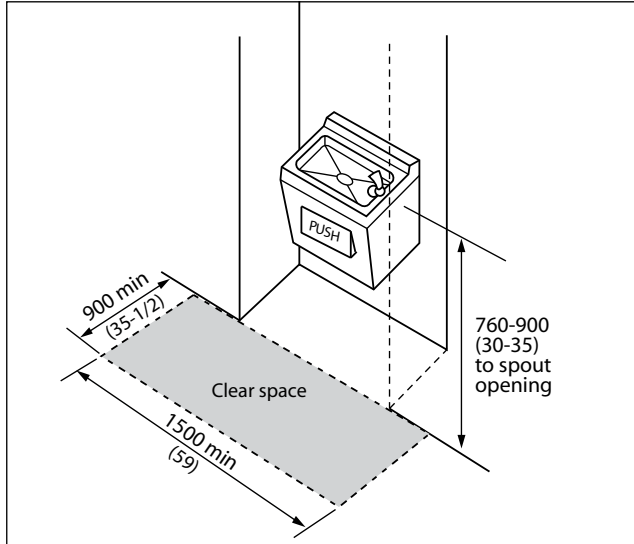

Figure 1.3.1.1 Parallel Approach to Drinking Fountain

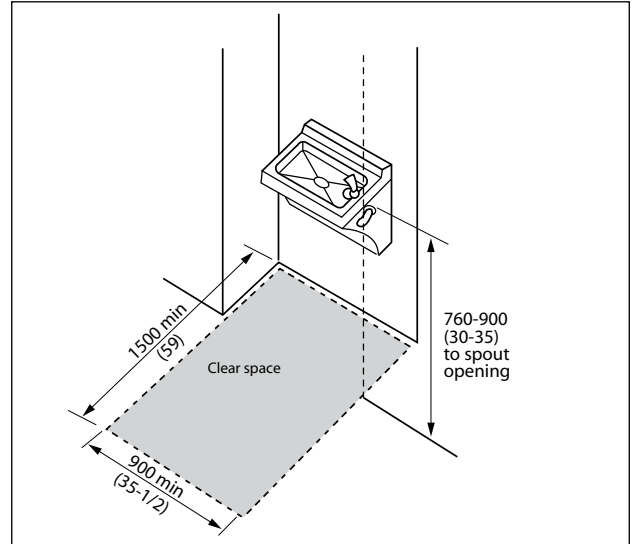

Figure 1.3.1.2 Frontal Approach to Drinking Fountain

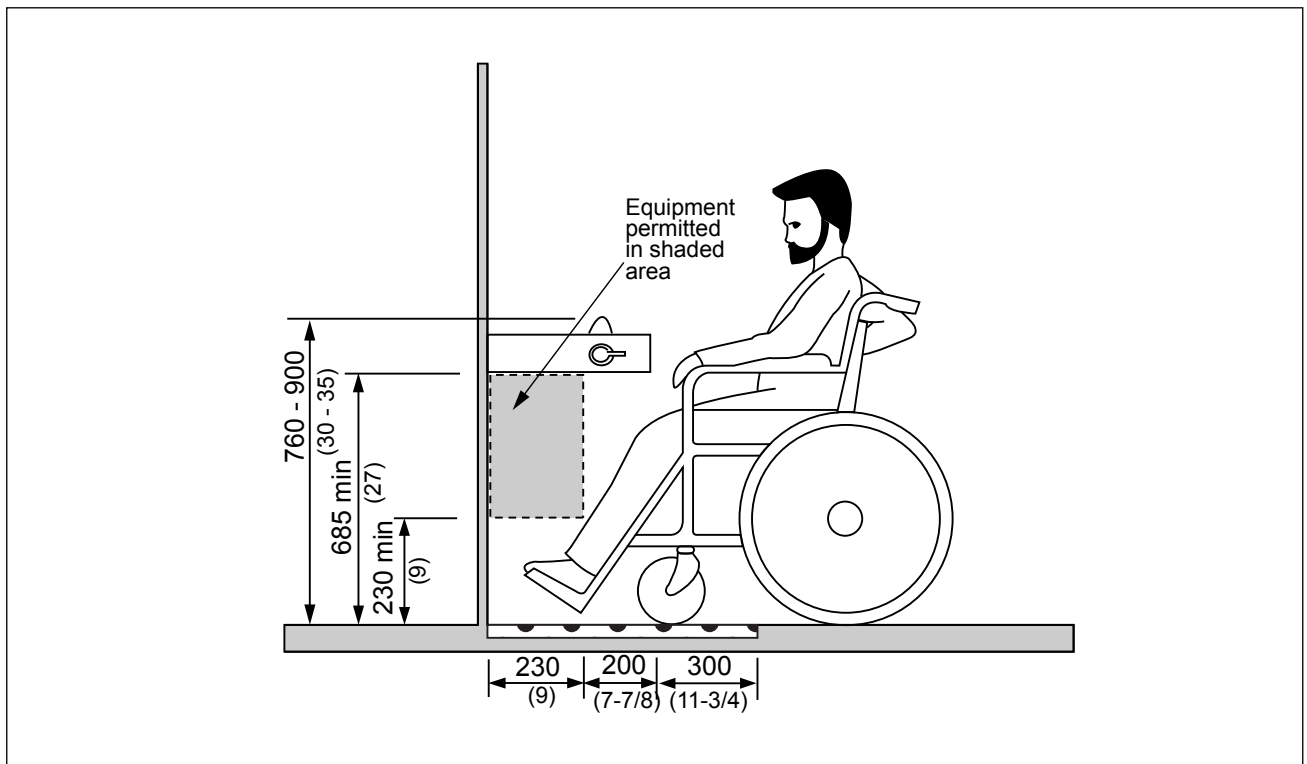

Figure 1.3.1.3 Clearances at Drinking Fountain

1.3 GENERAL AMENITIES

## 1.3.2 Vending and Ticketing Machines

### RATIONALE

Space in front of vending machines allows for maneuverability of mobility aids. Seating areas and tables adjacent to vending machines offer convenience and should accommodate the spatial requirements of wheelchairs. The selection of the machines should include a number of factors. Operating mechanisms should be within reach of children and individuals in wheelchairs. The mechanisms should be operable with one hand and minimal strength to accommodate people with limitations in dexterity. Lighting levels, tactile features and *colour contrasts* make the machine more *accessible* to those with vision *impairments*.

### APPLICATION

Vending and ticketing machines shall comply with this section.

### DESIGN REQUIREMENTS

Vending and ticketing machines shall be located adjacent to an *accessible route* in compliance with Section 1.1.3 Accessible Routes Paths, and Corridors.

Ticket dispensing machines and payment machines located along a *public right of way* shall be outside the *accessible route*.

*Clear space* in front of vending and ticketing machines shall conform to Section 1.1.1 Space and Reach Requirements.

The controls and operating mechanisms on vending and ticketing machines shall comply with Section 3.5.1 Control and Operating Mechanisms.

*Signage* on vending and ticketing machines shall be in highly contrasting lettering, raised at least 13 mm (1/2 in.) high. Ideally, lettering and *signage* shall comply with relevant parts of Section 1.2.4 Signage.

### RELATED SECTIONS

- 1.1.1 Space and Reach Requirements
- 1.1.2 Protruding and Overhead Objects
- 1.1.3 Accessible Routes, Paths and Corridors
- 1.2.1 Texture, Finishes and Colour
- 2.1.3 Streetscape
- 3.5.1 Controls and Operating Mechanisms

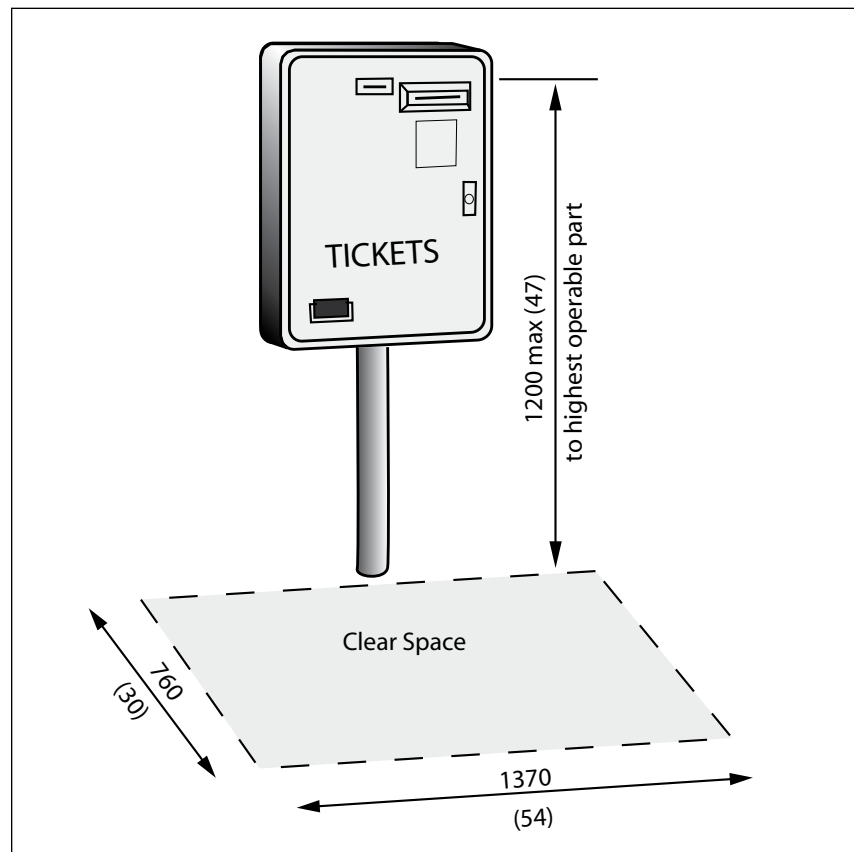

Figure 1.3.2.1 Ticket Dispensing Machine



1.3.2 Vending and Ticketing Machines

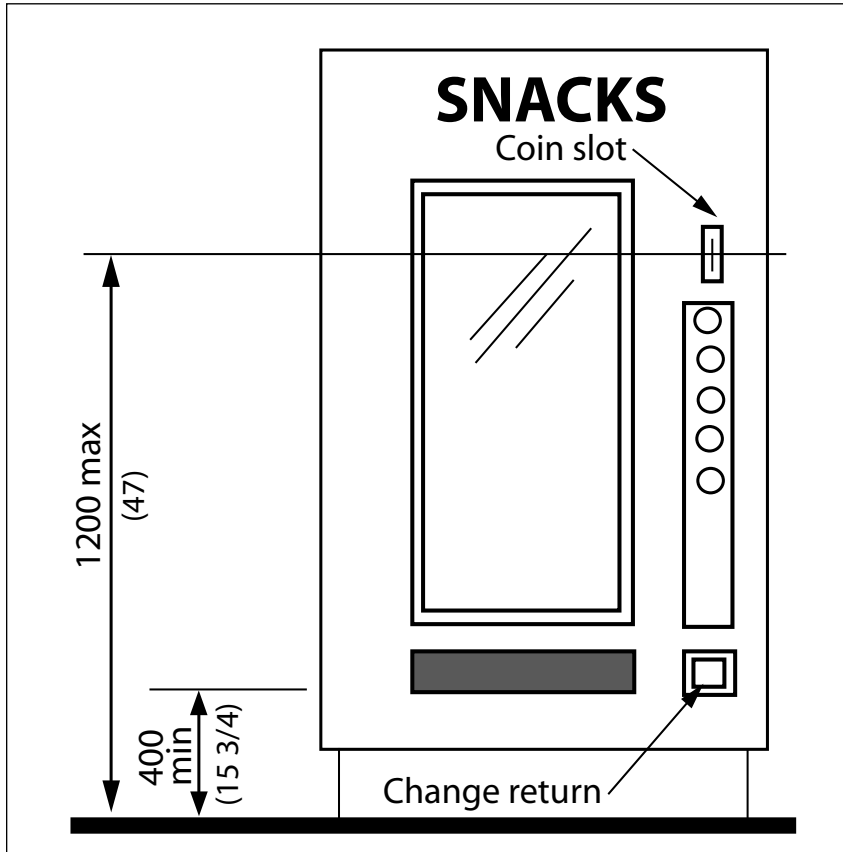

Figure 1.3.2.2 Vending Machine

# GENERAL STANDARDS

## 1.3.3 Elevated Areas and Platforms

### RATIONALE

Elevated areas and platforms, such as stage areas, speaker podiums, etc., should be *accessible* to all. A marked *accessible route* should be provided, along with safety features to assist persons who are visually impaired.

### APPLICATION

Elevated platforms provided for use by the general public, clients, customers or employees shall comply with this section.

### DESIGN REQUIREMENTS

Elevated platforms shall:

- be located on an *accessible route* that complies with Section 1.1.3 Accessible Routes, Paths and Corridors;
- in a retrofit situation, or when an *accessible route* is not available, be fitted with a ramp in compliance with Section 1.1.5 Ramps or a lift in compliance with Section 3.1.6 Platform Lifts;
- be capable of being illuminated to at least 100 lux (9.3 ft-candles) at floor level at the darkest point;
- have electrical outlets/cable outlets flush mounted for safety to prevent accidents;
- be sized to safely accommodate wheelchairs and other mobility equipment in compliance with Section 1.1.1 Space and Reach

Requirements; and

- where higher than 75 mm (3) have open platform edges defined by a *detectable warning surface*

Note: Where it is *technically not feasible* to comply with the above requirements, a temporary lift or ramp may be sufficient.

The *detectable warning surface* on elevated platforms shall:

- comply with the requirements of Section 1.2.6 Detectable Warning Surfaces;
- be consistent throughout the setting;
- be positioned parallel to the open platform edge, extending the full length of the platform; and
- be a minimum depth of 600 mm (23-5/8 in.) and a maximum of 920 mm (36 in.), flush from the open edge of the platform.

Where speaker podiums are provided they shall:

- be located on an *accessible route* in compliance with Section 1.1.3 Accessible Routes, Paths and Corridors;
- be height-adjustable for use from a seated or standing position;
- incorporate *clear* space of at least 900 mm (35-1/2 in.) by 1500 mm (59 in.), configured for forward approach;
- incorporate *clear knee space*

of at least 800 mm (31-1/2 in.) wide, 500 mm (19-5/8 in.) deep and 700 mm (27-1/2 in.) high; and

- incorporate controls and operating mechanisms in compliance with Section 3.5.1 Controls and Operating Mechanisms.

### RELATED SECTIONS

- 1.1.1 Space and Reach Requirements
- 1.1.2 Protruding and Overhead Objects
- 1.2.1 Texture, Finishes and Colour
- 1.2.6 Detectable Warning Surfaces
- 2.1.1 Exterior Ground Surfaces
- 2.1.3 Streetscape
- 3.1.1 Interior Floor Surfaces

1.3.3 Elevated Areas and Platforms (continued)

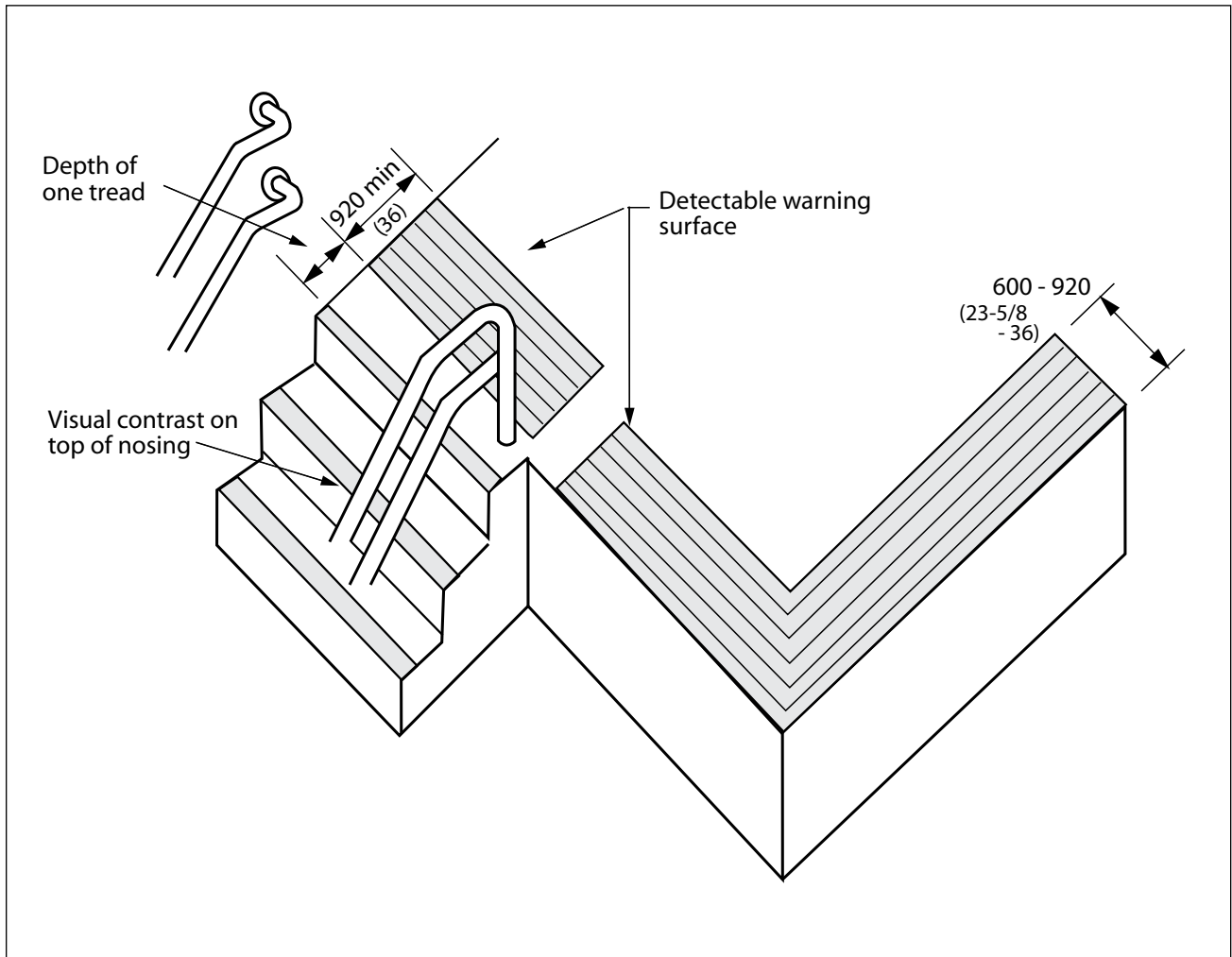

Figure 1.3.3.1 Detectable Warning Surfaces at Elevated Platform (example only)

# GENERAL STANDARDS

## 1.3.4 Waiting and Queuing Areas

### RATIONALE

Queuing areas for information, tickets or services should permit persons in wheelchairs or others with *disabilities* to move through the line safely and conveniently.

Waiting and queuing areas need to provide *space* for mobility devices, such as strollers, wheelchairs and scooters. Queuing lines that turn corners or double back on themselves will need to provide adequate *space* to maneuver mobility devices. Providing *handrails* in queuing lines may be useful support for individuals and guidance for those with vision *impairments*. The provision of seating in waiting areas is important for individuals who may have difficulty standing for extended periods.

Rope queuing systems are difficult for people who are visually impaired to use, and are a hazard to them when they walk through a queuing area.

### APPLICATION

Waiting and queuing areas shall comply with this section.

### DESIGN REQUIREMENTS

*Barriers* at queuing areas shall be laid out in parallel, logical lines, spaced a minimum of 1060 mm (42 in.) apart.

*Barriers* at queuing areas, provided to streamline people movement, shall be firmly mounted to

the floor, and should have rigid rails to provide support for waiting persons.

Where floor slots or pockets are included to receive temporary or occasional supports, such slots or pockets shall be level with the floor finish and have an integral cover, so as not to cause a tripping hazard.

Permanent queuing areas shall incorporate clearly defined floor patterns, colours and textures in compliance with Section 1.2.1 Texture, Finishes and Colour, as an aid to persons who are visually impaired.

There shall be a pronounced colour and texture contrast between ropes, bars or solid *barriers* used to define queuing areas and the surrounding environment.

Seating near queuing areas shall:

- be designed to carry a minimum load of 2.27 kN (500 lbs.);
- have a variety of seating with and without armrests and backs to accommodate individual abilities, sizes, and shapes.

Where it is technically not feasible to provide solid *barriers* in temporary settings, rope queues must be delineated with strong colour contrast and include orange safety cones beneath the rope line.

### RELATED SECTIONS

All relevant parts of Sections 1.0 General Design Standards, 2.0 Exterior Design Standards and 3.0 Interior Design Standards.

## 1.3.5 Seating

### RATIONALE

Indoor and outdoor seating provide convenient resting places for all individuals and are especially important for those who may have difficulty with standing or walking for extended periods.

Seating should be placed adjacent to pedestrian walkways to provide convenient rest places without becoming potential obstructions. Appropriate seat heights can facilitate sitting and rising for individuals such as senior citizens. Armrests provide assistance in sitting and rising. Ensure arm rest positioning and structural supports can accommodate people of different sizes and weights. For this reason, center armrests may be appropriate in some instances. Adequate supports provide for comfortable and safe seating for people of larger stature. Persons who are blind will find it easier to locate seating if they are located adjacent to a landmark, such as a large tree, a bend in a pathway, or a sound source.

### APPLICATION

All seating and seating areas, except those located off an accessible route in a dressing room, soft surface areas of *parks*, wilderness, beach or other non-hard surfaced areas, shall be *accessible* to all persons.

Seating in dressing rooms shall comply with Section 3.2.6 Specialty Change Rooms.

Seats should be provided at intervals along long routes (externally and internally) and where waiting is likely. Access to seating should be direct and unobstructed. All seating should be positioned on level, solid ground or flooring surface

### DESIGN REQUIREMENTS

Seating shall:

- be adjacent to an *accessible route* complying with Section 1.1.3 Accessible Routes, Paths and Corridors;
- be stable;
- have a seat height between 430 mm (17 in.) and 500 mm (19-5/8 in.) from the ground;
- a seat depth of at least 444 mm to 610 mm (17 1/2 in to 24 in.);
- have a minimum of two arm rests that:
  - shall be spaced no more than 700 mm (27 1/2 in.) and no less than 610 mm (24 in.). Where center armrests are provided they must allow a minimum seating area of 610 mm (24 in.). At least one seat shall be a minimum of 686 mm (27") in order to accommodate persons of larger stature.
- incorporate a minimum of one seat or bench with a back that:
  - is equal to the seat length that extends from a point no more than 50 mm (2 in.) above the seat surface to a point no less than 420 mm (16 1/2 in.) above the seat; and
- is located no more than 64 mm (2-1/2 in.) from the seat surface to the horizontal back boards of the seat;
- be *colour contrasted* to their background;
- remain stable when a horizontal or vertical load of 1.112 kN (250 pounds) is applied to any point on the seat, fastener, mounting device, or supporting structure;
- where installed in wet locations, the surface of the seat shall be slip-resistant and shall not accumulate water; and
- have an adjacent level, firm ground surface at least 920 mm (36 in.) x 1370 mm (54 in.), located at least 300 mm (12 in.) back from the *accessible* route. It is preferred that this adjacent surface be colour and texture contrasted to the *accessible* routes.
- have a load capacity of (2.27 kN (500 lbs.)).
- where rows of fixed seats are provided, such as in parks or waiting rooms, a clear space at least 920 mm wide X 1370 mm deep should be provided for wheelchair users in addition to space for manoeuvring. Space should be provided to enable two wheelchair users to sit alongside each other or for a stroller, service animals or wheelchair user to sit

# GENERAL STANDARDS

## 1.3.5 Seating (continued)

alongside a companion in a fixed seat (Figure 1.3.6.1) Proximate storage for a walker shall be provided.

- a clear width of 1200 mm should be maintained to a proportion of the cross-aisles to enable easy access for people who need more space
- a clear space, equivalent in size to a standard seat, within or at the end of a row in a block of seating should be provided for a service animal, clear of the aisles
- seating should be visually contrasting with the surrounding surfaces
- waste receptacles or bike

racks shall not be placed in the clear space beside the seating.

### RELATED SECTIONS

- 1.1.1 Space and Reach Requirements
- 1.1.2 Protruding and Overhead Objects
- 1.1.3 Accessible Routes, Paths and Corridors
- 1.2.1 Texture, Finishes and Colour
- 1.2.6 Detectable Warning Surfaces
- 2.1.1 Exterior Ground Surfaces
- 2.1.3 Streetscape
- 3.1.1 Interior Floor Surfaces

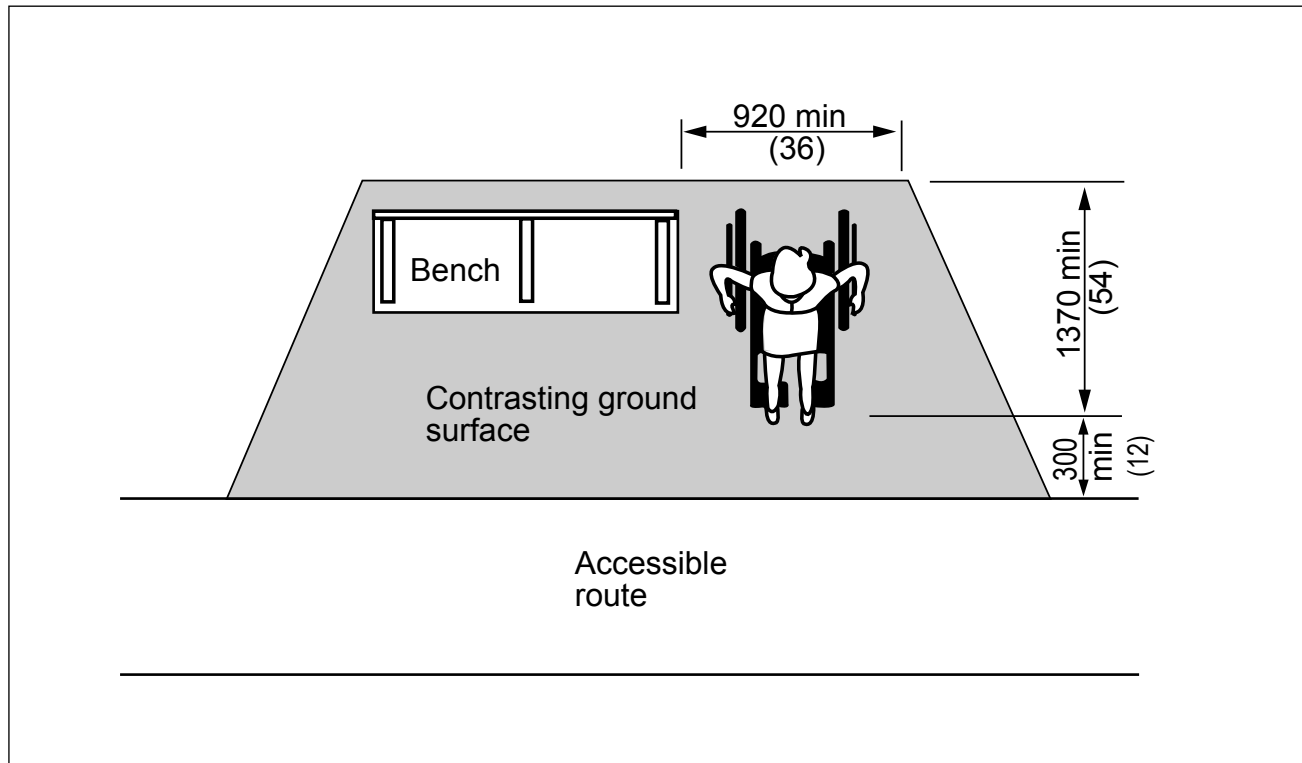

Figure 1.3.5.1 Bench in a Rest Area

1.3.5 Seating (continued)

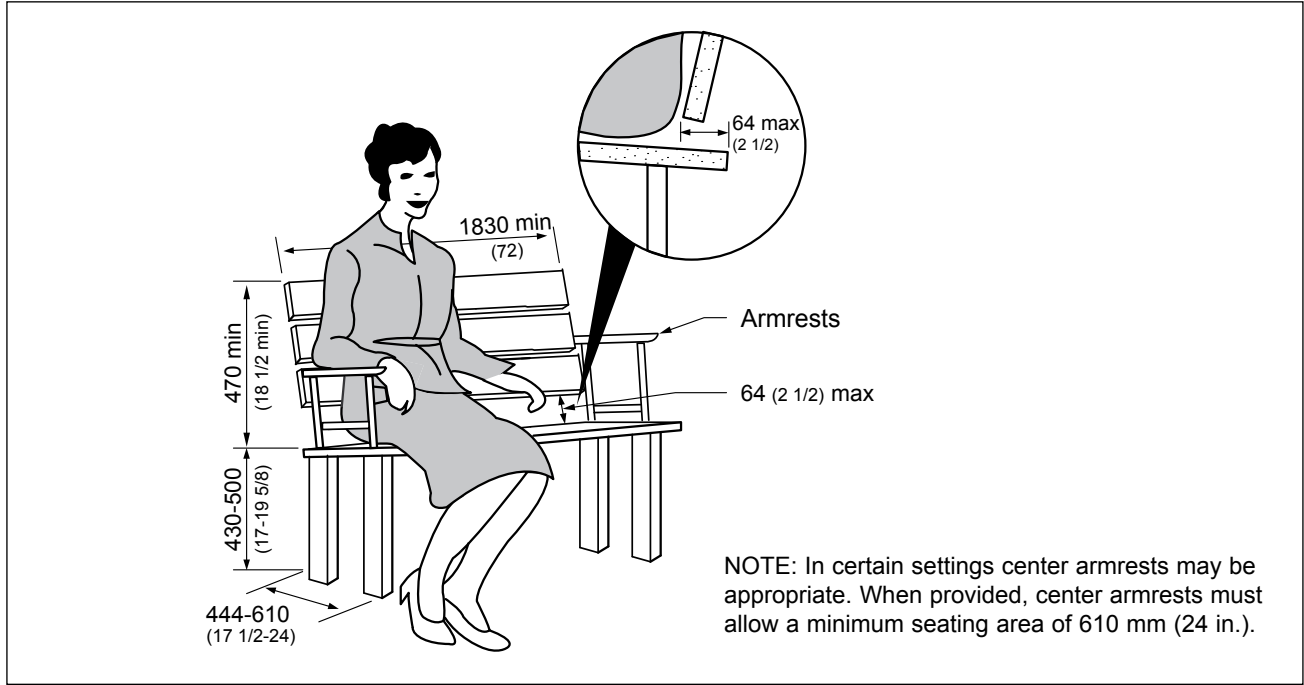

Figure 1.3.5.2 Example of Accessible Bench Seating

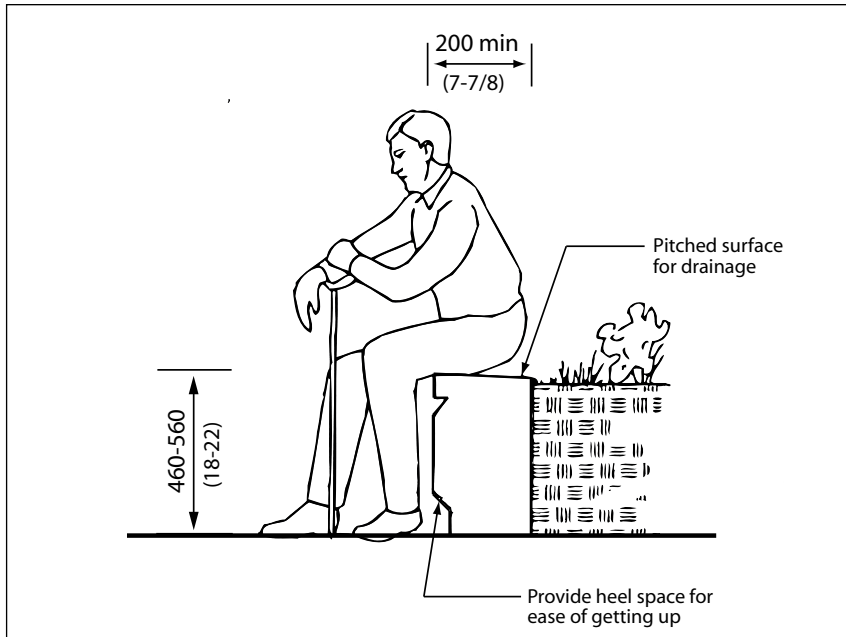

Figure 1.3.5.3 Example of Ledge Seating (Metric Handbook, Planning and Design Data, Second Edition)

1.3 GENERAL AMENITIES

# GENERAL STANDARDS

## 1.4.1 Water Facilities: Swimming Pools, Hot Tubs, Steam Rooms, Saunas and Spray Pads

### RATIONALE

Considerations must be given for accommodating persons who have mobility *impairments* include *accessible* change facilities and a means of access into the water. *Ramped* or sloped access into the water is preferred over lift access, as it promotes integration (everyone will use the *ramp*) and independence.

Universal changing areas accommodate people who transcend the social norms of male or female genders and accommodates various body types and identities.

Many persons who are visually *impaired* will benefit from colour and textural cues along primary routes of travel and at potentially dangerous locations, such as the edge of the pool, at steps into the pool, and at railings in compliance with 1.1.3.

Pools which feature the water level at the same level as the deck ('level-deck' design) are preferred.

### APPLICATION

In addition to the design requirements specified throughout the document, swimming pools, wading pools, hot pools, spray pads and therapy pools shall comply with this section.

Note: colours will vary with lighting levels and indoor and outdoor applications.

### DESIGN REQUIREMENTS

#### Change Rooms

Swimming pools, wading pools, hot pools and therapy pools shall have:

- a specialty change room in compliance with Section 3.2.6 Specialty Change Rooms;
- where the pool is indoors, a direct *accessible route* in compliance with Section 1.1.3 Accessible Routes, Paths and Corridors, from the lobby/*entrance* to the change rooms;
- a direct *accessible route* in compliance with Section 1.1.3 Accessible Routes, Paths and Corridors, from the change rooms to the shallow end of the pool deck;
- access from the pool deck into the water, provided by a sloped entry in compliance with this section. In *retrofit* situations where it is *technically not feasible* to provide a *ramp*, a mechanical pool lift can be used;
- a shower chair available at each *facility* for use in transferring into the water and/or shower;

#### Entrances to Water Facilities

- at least one accessible means of water entry must be provided
- beach entry is preferred
- handrails in compliance with Section 1.1.7 are required on both sides of the sloped entry regardless of the slope
- handrails are not required below the stationary water level

- sloped entries shall be slip resistant and be delineated at the start and end of the slope using colour and texture
- where steps are provided into the pool, steps must be marked with a *colour contrasting* strip at least 50 mm (2 in.) wide, at both the riser and the tread see Section 1.1.6. Steps must be affixed to the pool side rather than embedded/recessed into the concrete wall of the pool;
- where steps are provided into the pool, *colour contrasting handrails* on both sides of the steps are required. Such *handrails* shall extend at least 300 mm (11-3/4 in.) beyond the pool edge and recoil back to the post or ground level. (see Section 1.1.7)
- where an up-stand edge is provided, it shall be a minimum of 200 mm (7-7/8 in.) and a maximum of 400 mm (15-3/4 in.) in height;
- pool boundaries and water facility surfaces must have clearly defined boundaries using both a textural change and a *colour contrast* to both the water surface and surrounding pavement;
- firm, slip-resistant materials and finishes used on the pool perimeter, deck or paved areas surrounding the pool;
- non-abrasive and easy-to-clean pool perimeter finishes;
- adequate drainage on the pool deck to drain water quickly;
- where pool-depth indicator marking is provided, depth-indicator markings, as well

## 1.4 GENERAL CONTEXT SPECIFIC REQUIREMENTS



## 1.4.1 Water Facilities: Swimming Pools, Hot Tubs, Steam Rooms, Saunas and Spray Pads (continued)

as 'SHALLOW END' and 'DEEP END' markings, of a highly contrasting colour and sufficient size to be easily visible;

- where diving boards or platforms are provided, they shall be clearly marked and protected. Overhead clearances should be a minimum of 2100 mm (82-3/4 in.) or protected by suitable *guards*;
- where lanes, and/or lane markers are provided, they shall be of a highly contrasting colour. Tie-off devices for lane markers shall be positioned such that they do not create a tripping hazard;
- where starting blocks are provided, they shall be of a highly contrasting colour and capable of being securely fixed in place;
- safety equipment and other accessories shall be stored such that they do not present a tripping hazard; and
- lifeguard chairs, slides and other pool related structures shall be in highly contrasting colours.

Sloped entries to pools shall:

- comply with Sections 1.1.5 Ramps and 1.1.7 Handrails and Guards, except as modified below.
- extend to a depth of 610-760 mm (24-30 in.) below the stationary water level;
- where landings are required by 1.1.5, at least one landing shall be located 610-760

mm (24-30 in.) below the stationary water level. Exception: In wading pools, the sloped entry and landings, if provided, shall extend to the deepest part of the wading pool or spray pads; and

- incorporate two *handrails* complying with 1.1.7, with a *clear* width of 840-965 mm (33-38 in.) between.

Wading pool access shall be safe and gradual, so a child or a caregiver with a *disability* can independently access or be assisted into the water easily and/or use a wheelchair to enter.

Ramps into hot tubs, saunas or steam rooms must comply with section 1.1.5.

Spray pads must follow section 2.3.5 for playground requirements including slope for drainage, colour and texture around the edge of the spray pad area and non-slip surfacing. All stationary fixtures must be colour contrasted to the surrounding surfaces and have a accessible route in compliance with section 1.1.3. If a structure has a segment that is raised >27 inches from the surface it must be delineated in both colour and texture in compliance with section 1.1.2.

### RELATED SECTIONS

All relevant parts of Sections 1.0 General Design Standards, 2.0 Exterior Design Standards and 3.0 Interior Design Standards.

## 1.4 GENERAL CONTEXT SPECIFIC REQUIREMENTS

# GENERAL STANDARDS

## 1.4.2 Public Historic Places

### RATIONALE

Providing people of all ages, interests and capacities with broad, general access to *public historic places* is a highly desirable social goal. It is important to ensure that such access is accompanied by adequate psychological comfort and dignity. Many users of *public historic places* are the same demographic market that is growing older, becoming less mobile, and often has compromised hearing and vision.

Design solutions that best balance accessibility needs with heritage values are those that enhance the use and appreciation of a property for everyone. Work should be carefully planned and undertaken so that damage to the heritage value and character-defining elements of a public historic place is minimized. The objective is to provide the highest level of access with the lowest level of impact. To determine the most appropriate solutions to access problems, it is recommended that accessibility and conservation specialists, as well as affected users, be consulted early in the planning process. The planning process should begin with an evaluation of the current strengths and weaknesses of the *public historic place* to identify the quality of existing means of access and *wayfinding* tools.

### APPLICATION

The City of Winnipeg owns and occupies a variety of *public his-*

*toric places*, many of which are on the list of historic resources. They include but are not limited to former city halls, early office towers, theatres, swimming pools, fire/paramedic and ambulance stations, and libraries. Workplaces, services and facilities must be adapted so that persons with *disabilities* can participate in society equitably, and with dignity. For *alterations* to all *public historic places*, the Historic Buildings and Resources Committee is required to review the proposal for compliances with the 'Standards and Guidelines for the Conservation of Historic Places in Canada'.

### DESIGN REQUIREMENTS

In the 'Standards and Guidelines for the Conservation of Historic Places in Canada', the following recommendations are proposed for accessibility upgrades to historic places. Please refer to the entire document for further detail.

- Identify the heritage value of the historic place and character-defining *elements* - materials, forms, location, spatial configurations, uses and cultural associations or meanings - so that required accessibility modifications will not damage or destroy them.
- Comply with accessibility requirements in such a way that character-defining elements are conserved and heritage value maintained.
- Work with accessibility and conservation specialists and

affected users to determine the most appropriate solution to access problems that will have the least impact on character-defining elements and overall heritage value.

- Provide accessibility that promotes independence for the *disabled* person to the highest degree practicable, while conserving the heritage value and character-defining elements and within the confines of Human Rights Reasonable Accommodation
- Adapt the intervention to its anticipated lifespan, so that short-term improvements remain as reversible as possible.
- Find solutions to meet accessibility requirements that minimize the impact on the historic place and its environment.

### RELATED SECTIONS

All relevant parts of Sections 1.0 General Design Standards, 2.0 Exterior Design Standards and 3.0 Interior Design Standards.

**1.4.3 Fixed Seating Assembly Facilities**

**RATIONALE**

Designated viewing areas are required for individuals unable to use typical seating. Viewing areas need to provide adequate *space* to maneuver a mobility device as large as a scooter and should not be limited to one location. Designated companion seating should also be provided. *Guards* placed around a viewing area should not interfere with the line of sight of someone sitting in a wheelchair. A choice of locations and ticket price range should be available. There should be seating options for families with a member who is *disabled*, to sit together as a family. Ensure that wheelchair seating does not block sight lines for others.

**APPLICATION**

In places of assembly with fixed seating, *accessible* wheelchair locations shall comply with this section and shall be provided in numbers as indicated by Table 1.4.3.1.

In addition, 1%, but not less than one, of all fixed seats shall accommodate service dogs and be located close to the *access aisle*. A sign or marker shall identify each of the seats. *Signage* notifying patrons of the availability of such seats shall be posted at the ticket office.

In addition, 1%, but not less than one, of all fixed seats shall be aisle seats with no armrests

on the aisle side, or shall have removable or folding armrests on the aisle side. This will accommodate bariatric users or ease of transfer from a mobility device. A sign or marker shall identify each of the seats. *Signage* notifying patrons of the availability of such seats shall be posted at the ticket office to accommodate bariatric sizes or ease of transfer.

**DESIGN REQUIREMENTS**

*Accessible* wheelchair locations shall adjoin an *accessible route* complying with Section 1.1.3 Accessible Routes, Paths and Corridors, without infringing on egress from any row of seating or any aisle requirement.

<b>Number of Fixed Seats in Seating Area</b>	<b>Number of Spaces Required for Wheelchairs</b>
2-100	2
101-200	3
201-300	4
301-400	5
401-500	6
501-900	7
901-1300	8
1301-1700	9
each increment of up to 400 seats in excess of 1700	One additional space

**Table 1.4.3.1** Wheelchair Viewing Locations

1.4 GENERAL CONTEXT SPECIFIC REQUIREMENTS

# GENERAL STANDARDS

## 1.4.3 Fixed Seating Assembly Facilities (continued)

Each *accessible* wheelchair location shall be:

- an integral part of any seating plan. Seats shall be distributed in a manner that provides people with physical *disabilities* a choice of admission prices and lines of sight comparable to those for members of the general public;
- *clear* and level, or level with removable seats;
- if the wheelchair enters from a side approach, not less than 920 mm (36 in.) wide and 1525 mm (60 in.) long;
- if the wheelchair enters from a front or rear approach, not less than 920 mm (36 in.) wide and 1370 (54 in.) long;
- arranged so that at least two designated wheelchair locations are side by side;
- arranged so that at least one companion fixed seat is provided next to each wheelchair seating area; and
- where the seating capacity exceeds 100, provided in more than one location.

### RELATED SECTIONS

- 1.1.1 Space and Reach Requirements
- 1.1.2 Protruding and Overhead Objects
- 1.1.3 Accessible Routes, Paths and Corridors
- 1.2.1 Texture, Finishes and Colour
- 1.2.2 Acoustics
- 1.2.3 Public Address Systems
- 1.2.4 Signage
- 2.1.1 Exterior Ground Surfaces
- 3.1.1 Interior Floor Surfaces

1.4.3 Fixed Seating Assembly Facilities (continued)

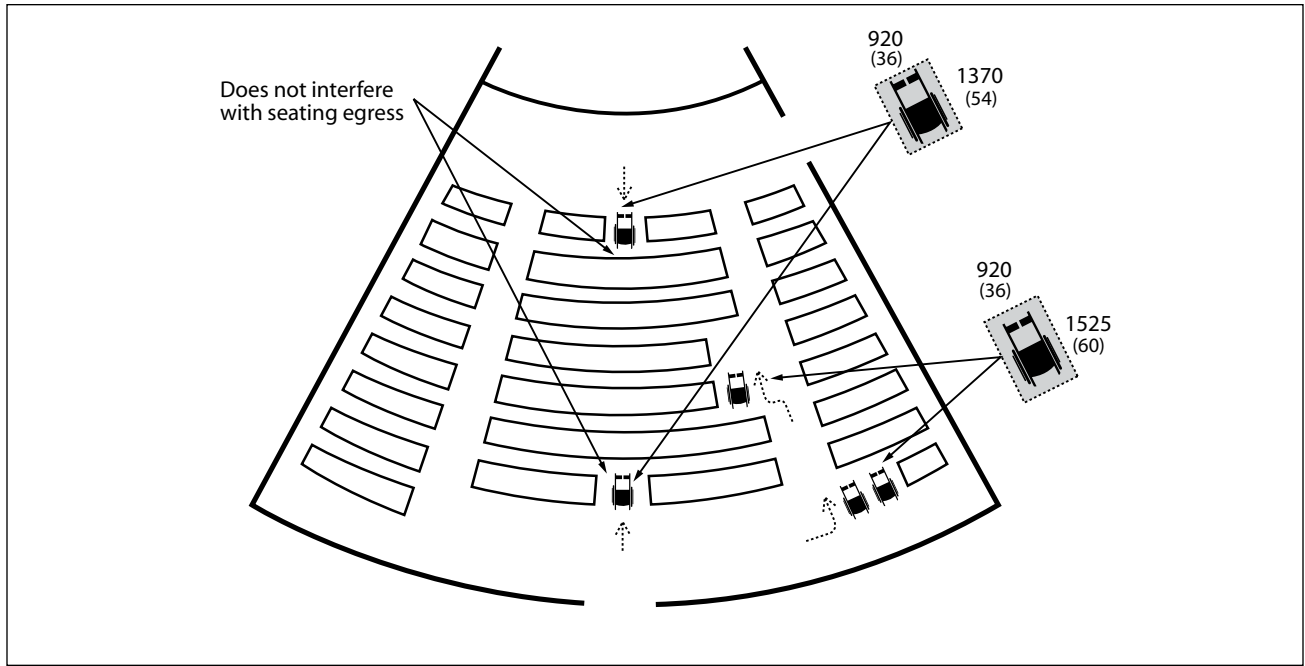

Figure 1.4.3.1 Distribution of Wheelchair Locations

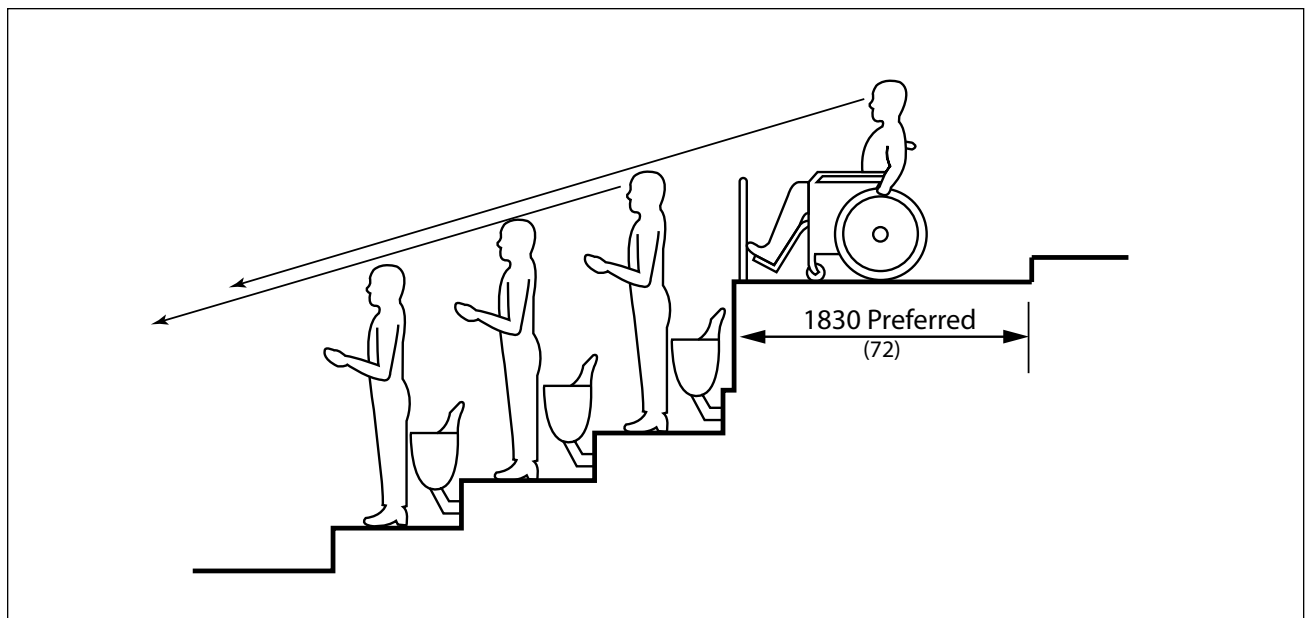
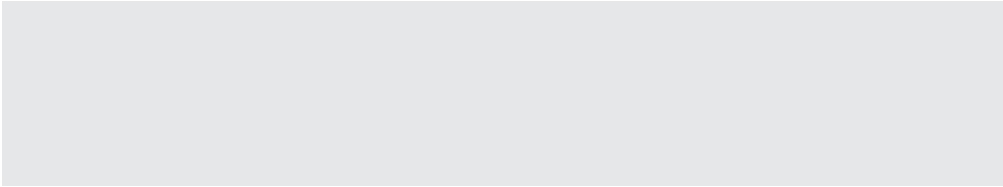
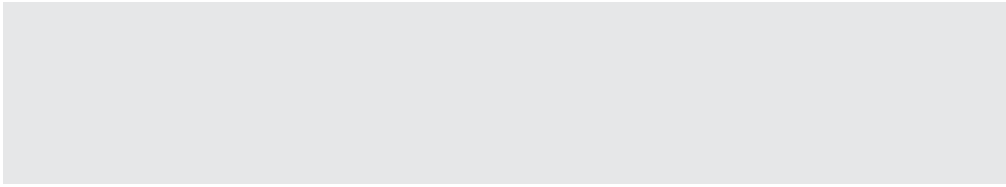

Figure 1.4.3.2 Sight Lines at Wheelchair Viewing Locations

1.4 GENERAL CONTEXT SPECIFIC REQUIREMENTS





## **EXTERIOR STANDARDS**

# EXTERIOR STANDARDS

## 2.1.1 Exterior Ground Surfaces

### RATIONALE

The selection of ground materials can be critical to the safe and easy movement all persons including persons using mobility aids and persons with low vision.

Irregular surfaces, such as cobblestones or pea-gravel are difficult for either walking or pushing a wheelchair. Slippery surfaces are hazardous to all individuals and especially for seniors and others who may not be sure-footed.

Small and uneven changes in surface level represent a further barrier to using a wheelchair but also present a tripping hazard to ambulatory persons. Openings in grates or grilles can catch canes or wheelchair wheels.

### APPLICATION

Ground surfaces along all routes shall comply with this section.

All applicable parts of section 1.1.3 Accessible Routes, Paths and Corridors must be adhered to.

### DESIGN REQUIREMENTS

Sidewalk *accessible routes* shall be concrete. Pavers shall not be used in an *accessible route* unless avoidance is *technically not feasible*.

Where the use of concrete is *technically not feasible*, asphalt, compacted gravel screenings, interlocking pavers and patio stones may be used. Pavers can include either precast con-

crete paving stones or clay brick. Pavers or patio stones should not be used in a long run of walkway (>30m or 98 ft.)+

Pavers are acceptable for use as secondary surfacing (in patios, furniture zones etc.) or to delineate the concrete *accessible route*.

Where interlocking pavers are used they must be installed on a stable base that is not susceptible to movement from frost heave or other factors.

Pavers shall have joint spacing not more than  $0 \pm 5$  mm (1/4 in.). Exception: Pavers with beveled edges shall have a maximum spacing of 10 mm (1/2 in.)

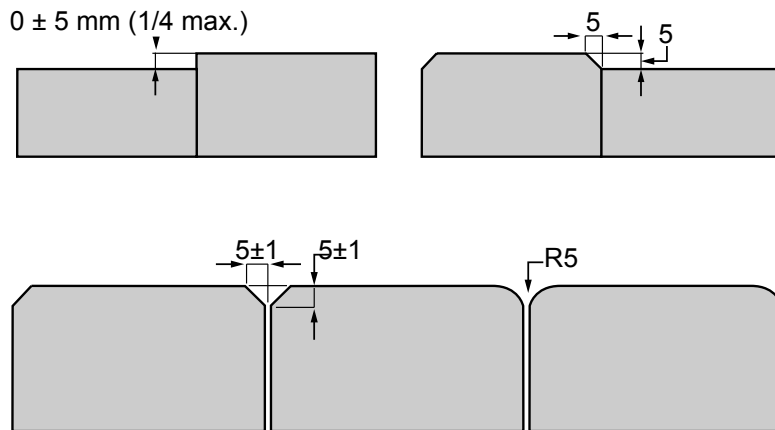

**Figure 2.1.1.1** Joint Spacing in Pavers and Abutment of Surfaces



**2.1.1 Exterior Ground Surfaces (continued)**

between the edges of the bevel on the top surface of the pavers or a radius of R5 if rounded edges. (Figure 2.1.1.1)

Suitable surfaces for outdoor pedestrian trails include asphalt, concrete and well-compacted limestone or shale screenings.

Wood chip use must be limited to short segments of low use trails. Accessibility signage at the head of the trail must indicate a trail difficulty rating.

Steps shall be finished with a non-slip, non-glare material and incorporate highly contrasted nosings (See Section 1.1.6) .

*Ramp* surfaces shall be firm and non-slip (See Section 1.1.5).

Ground surfaces shall be stable, firm, slip resistant and glare-free.

Ground surfaces shall not be heavily patterned.

Changes in level, except for elevators and other elevating devices, shall conform to Table 2.1.1.1 and Figure 2.1.2.1.

Catch basins, hydro vaults, man-hole covers or drainage inlets shall

- not be located in the *accessible route*; and
- be relocated if already existing in an *accessible route* where possible.

If relocation of an existing catch basin, tree grate or drainage inlet is *technically not feasible*, the grate and inlet cover shall

- have spaces not greater than 10 mm (3/8 in.) wide in one direction; and
- be placed so that the long

dimension is perpendicular to the dominant direction of travel (See Figures 2.1.1.3 & 2.1.1.4)

**RELATED SECTIONS**

- 1.1.3 Accessible Routes, Paths and Corridors
- 1.1.5 Ramps
- 1.1.6 Stairs
- 1.2.1 Texture, Finishes and Colour
- 1.2.6 Detectable Warning Surfaces
- 2.1.3 Streetscape
- 2.1.5 Curb Ramps and Truncated Dome Detectable Warning

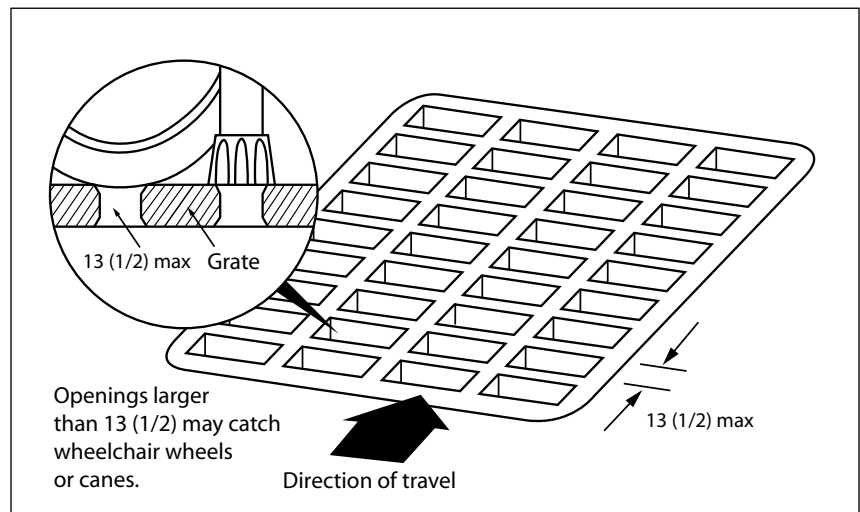

**Figure 2.1.1.3** Grills and Gratings

Vertical Rise	Edge Treatment
0 to 5 mm (0 - 1/4")	May be vertical
6 mm (1/4") or more	Treat as a sloped surface, <i>ramp</i> or <i>curb ramp</i>

**Table 2.1.1.1** Changes in Ground Level (see Figure 3.1.1.2)

2.1.1 Exterior Ground Surfaces (continued)

Surfaces

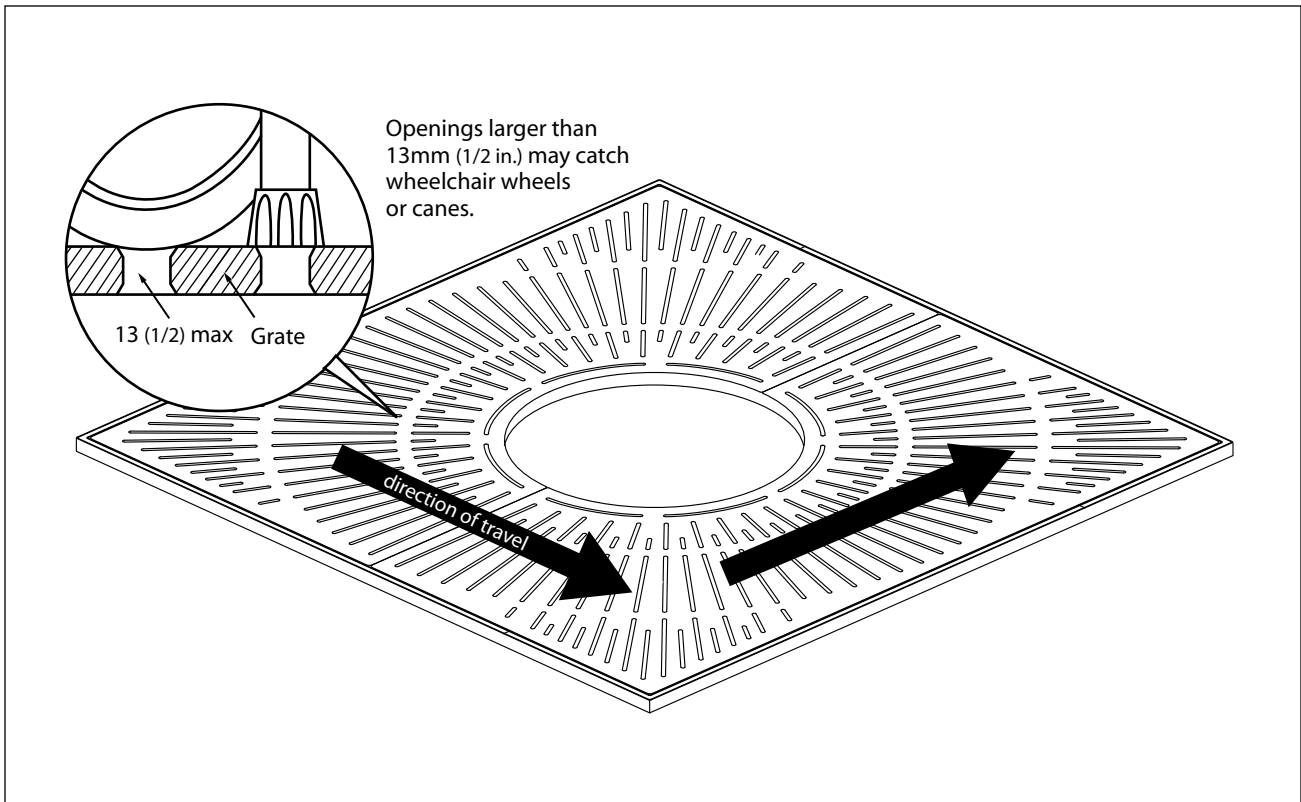

Figure 2.1.1.4 Example of an Accessible Tree Grate

## 2.1.2 Exterior Lighting

### RATIONALE

Artificial lighting and natural light sources should provide comfortable, evenly distributed light at all working areas, in all circulation routes and in all areas of potential hazard. Also, outdoor lighting should be provided at *entrances*, along frequently used access routes and at frequently used outdoor amenities.

It is important to keep the principles of Crime Prevention through Environmental Design in mind when lighting a facility.

### APPLICATION

Exterior lighting systems shall comply with this section.

### DESIGN REQUIREMENTS

Exterior lighting shall be in compliance with the 'Illuminating Engineering Society of North America Standards' in all public thoroughfares, and at all pedestrian routes, to provide safe access for persons with *disabilities* from sidewalks, bus stops and parking areas to nearby *facilities* and amenities.

At pedestrian *entrances*, lighting levels should be minimum 100 lux (9.4 ft-candles) consistently over the *entrance* area, measured at the ground. Public entrances require a fuller spectrum of light  $\geq 84$  CRT.

Over frequently used pedestrian routes, including walkways,

paths, stairs and *ramps*, lighting levels shall be minimum 5 lux (.5 ft-candles) consistently over the route, measured at the ground.

At frequently used *accessible* parking *spaces* and limited mobility *spaces*, lighting levels shall be minimum 5 lux (.5 ft-candles) for parking lots and 10 lux (1 ft-candle) for parking garages, measured at the ground.

Lighting levels at passenger drop-off areas shall be minimum 30 lux (3 ft-candles) consistently over the drop-off area, measured at the ground.

At frequently used steps and stairs, lighting shall be located at or beside the steps or stairs, to clearly define the treads, risers and nosings.

All lighting shall

- provide a good colour spectrum; and
- be evenly distributed to minimize cast shadows.

Supplementary lighting shall be provided to highlight key *signage* and orientation landmarks.

Low-level lighting shall be high enough to *clear* normal snow accumulation.

Lighting fixtures shall comply with the relevant parts of Sections 1.1.2 Protruding and Overhead Objects and 2.1.3 Streetscape.

### RELATED SECTIONS

All relevant parts of Sections 1.0 General Design Standards, 2.0 Exterior Design Standards and 3.0 Interior Design Standards.

# EXTERIOR STANDARDS

## 2.1.3 Streetscape

### RATIONALE

Maintaining an *accessible route* is important to all individuals using pathways and sidewalks. Unless properly located, *street elements* such as newspaper boxes, waste receptacles, benches, outdoor patios and bus shelters present a *barrier* to all pedestrians, especially those that require additional *space* for use of wheelchairs, scooters, strollers, pulling suitcases or moving delivery carts.

For persons with a vision *impairment*, unidentified obstructions within pathways and sidewalks can present a hazard.

*Accessible route* should always consist of a smooth, firm, and solid surface such as asphalt or concrete. It is important to define edges using a *detectable warning*

(Refer to 1.2.1 and 1.2.6)

Outdoor patios encroaching on pedestrian pathways and sidewalks must incorporate railings that are easily distinguished both visually and by cane.

The efficient and thorough removal of snow and ice are also essential to outdoor pathways. Negotiating a wheelchair or stroller through a snow covered path is exceptionally difficult. Icy surfaces are hazardous to all pedestrians, especially individuals such as senior citizens who may not be sure-footed.

Benches can provide a resting place for an individual experiencing difficulty in walking distances. Such furniture should incorporate strong *colour contrasts* and be located off pathways, to minimize

potential as an obstruction.

### APPLICATION

All *street elements*, including *street elements* that are located inside or outside of *facilities*, including but not limited to, waste receptacles, light standards, signs, planters, mail boxes, vending machines, benches, fire hydrants, traffic signals, red-light cameras and utility boxes contained within a *public right-of-way*, shall comply with this section.

### DESIGN REQUIREMENTS

Where sidewalks are provided as part of the *public right-of-way*, within the Winnipeg Downtown Core Area, an *accessible route* at least 1900 mm (75 in.) wide shall be maintained along the side-

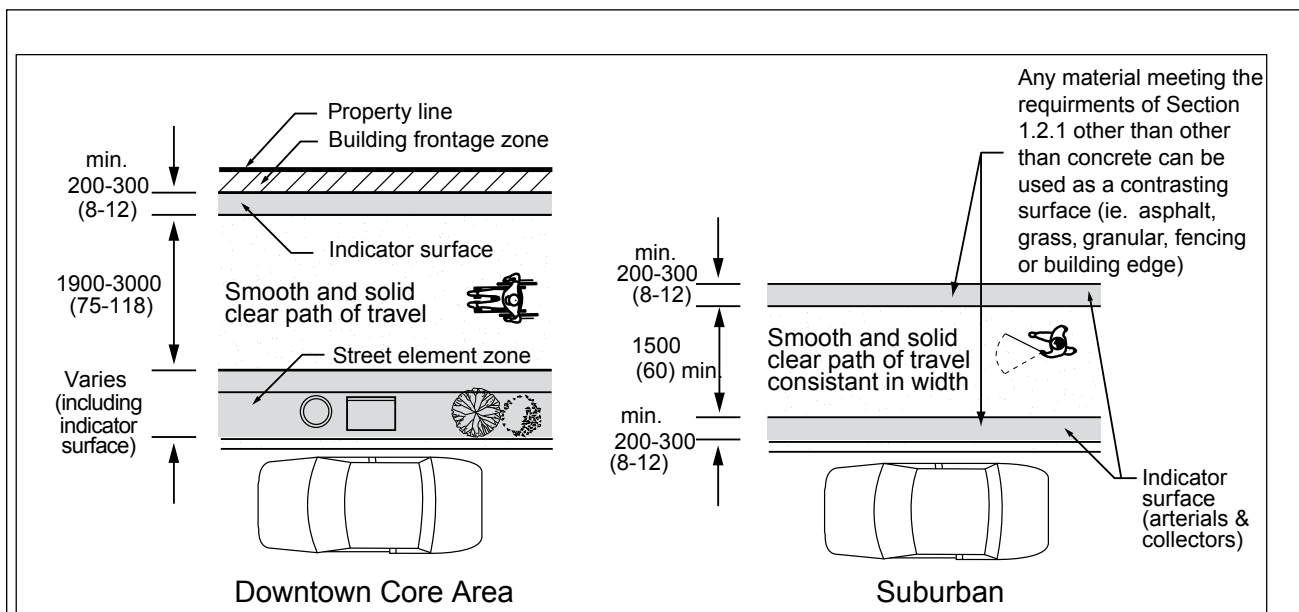

Figure 2.1.3.1 Arterial and Collector Sidewalks

2.1.3 Streetscape (continued)

walk.

Where sidewalks are provided as part of the *public right-of-way*, outside Winnipeg's downtown core area as per Winnipeg Zoning By-Law 200-2006, an *accessible* space at least 1900 mm (75 in.) wide shall be maintained along the sidewalk. This includes a *accessible route* of 1500 mm (59 in.) and an *indicator surface* of a minimum of 200 – 300 mm (7 13/16 in. - 11 13/16 in.) in width on either side of the *accessible route*.

Clearances along *accessible routes* within *public rights-of-way* must comply with Sections 1.1.2 Protruding and Overhead Objects, 1.1.3 Accessible Routes, Paths and Corridors and 2.1.1 Exterior Ground Surfaces and

1.2.1 Texture, Finishes and Colour.

*Street elements* shall:

- be consistently located within the *street element zone* of the *accessible* space;
- where the *street element zone* is not identified with *indicator surfaces*, individual *street elements* must be *cane-detectable*, in compliance with Section 1.1.2 Protruding and Overhead Objects; and
- be securely mounted.

*Street elements* shall incorporate *colour contrast* to differentiate them from the surrounding environment. Refer to 1.2.1 Texture, Finishes and Colour.

Waste receptacles and recycling bins in *accessible* open areas, such as *parks*, wilderness areas, beaches or picnic areas, shall be mounted on firm, level pads adjacent to the path or sidewalk (but not directly beside seating areas).

Waste receptacles and recycling bins shall be clearly identified by suitable lettering, in compliance with the relevant parts of Section 1.2.4 Signage.

Where lids or openings are provided on waste receptacles and recycling bins, they shall be mounted no higher than 1060 mm (42 in.) above the adjacent floor or ground surface. Opening mechanisms shall comply with Section 3.5.1 Controls and Operating Mechanisms.

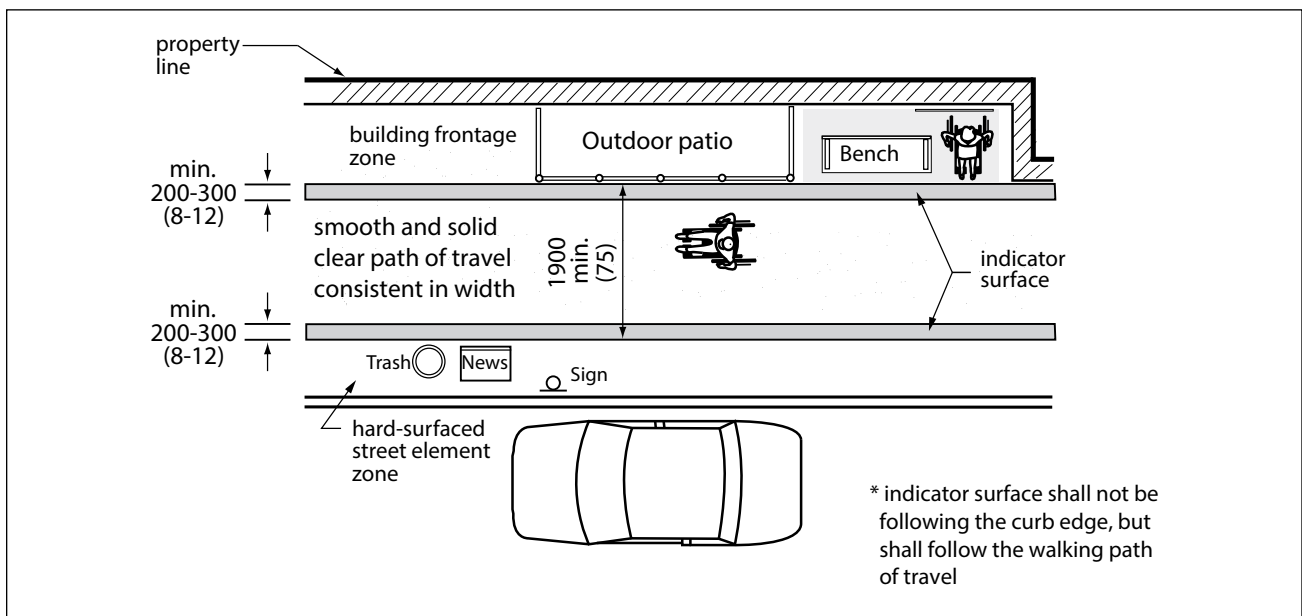

Figure 2.1.3.2 Downtown Core Area Streetscape

2.1 EXTERIOR ACCESS AND CIRCULATION

# EXTERIOR STANDARDS

## 2.1.3 Streetscape (continued)

	RELATED SECTIONS
On- <i>street</i> letter boxes and community letter boxes shall:	
<ul style="list-style-type: none"><li>• be located immediately adjacent to an <i>accessible route</i>;</li><li>• incorporate a <i>clear</i> area at least 760 mm (30 in.) wide x 1370 mm (54 in.) long in front of usable parts;</li><li>• ensure the <i>clear area</i> can be accessed from the adjacent <i>accessible</i> route in compliance with Section 1.1.3 Accessible Routes, Paths and Corridors;</li><li>• where provided, have slots for posting mail located to be reachable from a seated position (refer to Section 1.1.1);</li><li>• where provided, have at least 10%, but no less than one, mailbox for collecting mail, located to be reachable from a seated position;</li><li>• have operating mechanisms in compliance with Sections 3.5.1 Controls and Operating Mechanisms; and</li><li>• be kept clear of snow.</li></ul>	<ul style="list-style-type: none"><li>1.1.1 Space and Reach Requirements</li><li>1.1.2 Protruding and Overhead Objects</li><li>1.1.3 Accessible Routes, Paths and Corridors</li><li>1.2.1 Texture, Finishes and Colour</li><li>1.2.4 Signage</li><li>1.2.6 Detectable Warning Surfaces</li><li>1.3.6 Benches</li><li>2.1.1 Exterior Ground Surfaces</li><li>2.1.2 Exterior Lighting</li><li>2.1.5 Curb Ramps and Truncated Dome Detectable Warning Surfaces</li><li>2.2.1 Balconies, Plazas and Patios</li><li>2.2.3 Picnic Tables</li><li>2.3.1 Parking</li><li>2.3.2 Passenger Loading Zones</li></ul>

## 2.1.4 Traffic Signal Poles

### RATIONALE

Persons who use mobility devices such as wheelchairs and scooters need to be able to reach and use the pushbuttons that control pedestrian signals at crosswalks. Access issues include the provision of appropriate space beside the pushbuttons, as well as the button configuration and mounting height.

Where practical, all poles should align with existing above ground *elements* running parallel to the *accessible route*.

### APPLICATION

In new construction, where traffic signal poles with pushbuttons are provided to control pedestrian access to crosswalks, they shall comply with this section (retrofits will comply where possible).

### DESIGN REQUIREMENTS

Signal poles with pushbuttons to control pedestrian access to crosswalks shall be:

- adjacent to an *accessible route* complying with Section 1.1.3 Accessible Routes, Paths and Corridors;
- unobstructed from the location of crossing;
- parallel to the direction of the crosswalk controlled by the pushbutton;
- 300-500 mm (11-3/4 - 19-5/8 in.) from the lowest edge of the *curb ramp*; and
- 800-1500 mm (31-1/2 - 59

in.) from the back of the curb line. Note: The ideal location for the signal pole is 1000 mm (39-3/8 in.) from the back of the curb line.

Pushbuttons mounted on signal poles shall:

- be mounted 914 mm (36 in.) +/- 25 mm (1 in.) above the sidewalk grade for approach;
- incorporate a painted yellow square or reflective tape on the post behind the activation button, that is at least twice the size of the push-button enclosure; and
- be operable
  - using one hand; and
  - with a force of less than 13 N ( 3 lb.).

Where there are two pedestrian signals on the same corner, the push-buttons shall be mounted on poles separated by at least 3000 mm (118 in.). Refer to Figure 2.1.4.1.

Exception: If the requirements for separation cannot be met, two *accessible* pedestrian signal-related buttons may be installed on a single pole. The traffic signal pole shall be placed in the middle of the two *curb ramps*.

If two push-buttons are installed on the same pole, the *accessible* pedestrian signals shall be equipped to provide two sound messages facing the crosswalk that has the walk signal indication. Refer to Figure 2.1.4.2.

### RELATED SECTIONS

- 1.1.1 Space and Reach Requirements
- 1.1.2 Protruding and Overhead Objects
- 1.1.3 Accessible Routes, Paths and Corridors
- 1.2.1 Texture, Finishes and Colour
- 1.2.6 Detectable Warning Surfaces
- 2.1.1 Exterior Ground Surfaces
- 2.1.3 Streetscape
- 2.1.5 Curb Ramps and Truncated Dome Detectable Warning Surfaces
- 3.1.1 Interior Floor Surfaces

# EXTERIOR STANDARDS

## 2.1.4 Traffic Signal Poles (continued)

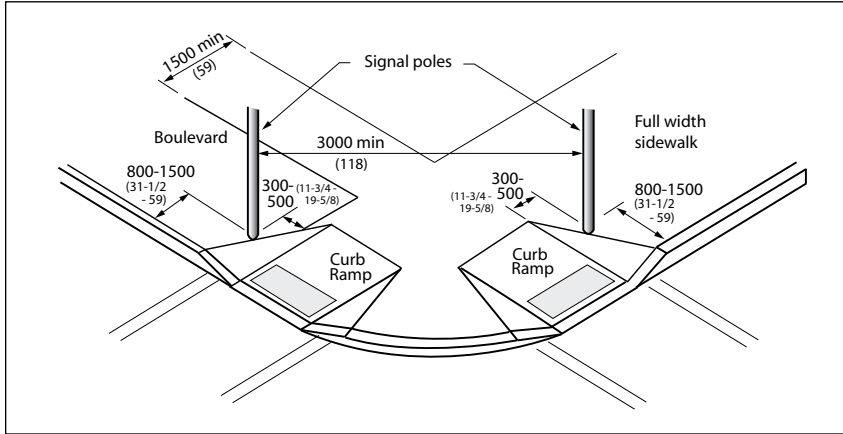

**Figure 2.1.4.1** Corner with Two Traffic Signal Poles

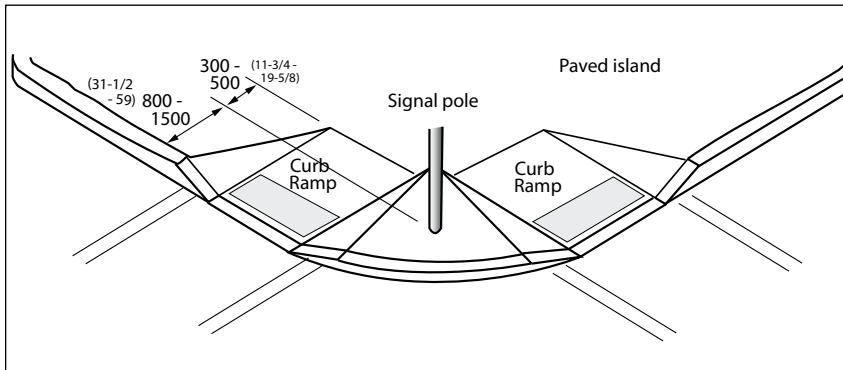

**Figure 2.1.4.2** Corner with One Traffic Signal Pole

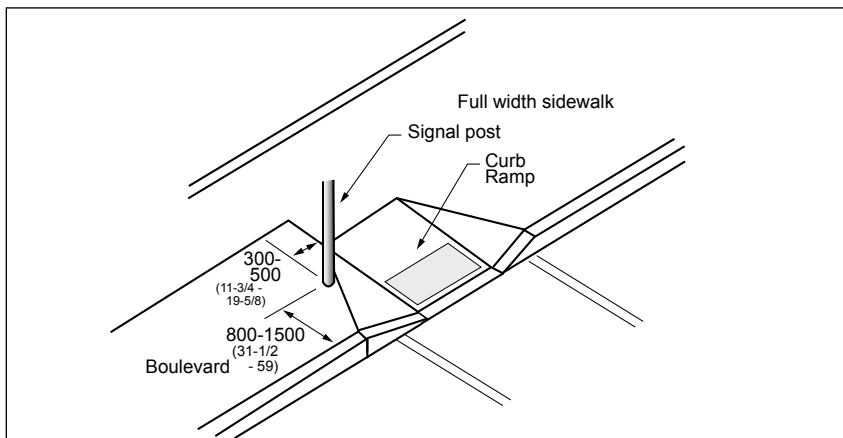

**Figure 2.1.4.3** Mid-Block Crossing with One Traffic Signal Pole



## 2.1.5 Curb Ramps and Truncated Dome Detectable Warning Surfaces

### RATIONALE

In the interest of moving people safely and efficiently on and off road, the design of *curb ramps* is very important. The same issues related to the slopes of *ramps* apply equally to slopes of *curb ramps*. Refer to Section 1.1.5

A well-designed *curb ramp* can be spoiled by an uneven or gapped transition between the road surface and *curb ramp*. Flared sides on the *curb ramp* eliminate the hazard of pedestrians stepping off of an edge. While a smooth transition and minimal slope are ideal for someone in a wheelchair, they are a potential hazard to an individual with a vision *impairment* who may not notice the transition from sidewalk to *street*. *Truncated dome detectable warning surfaces* become an important safety feature in this scenario.

Snow accumulation at *curb ramps* shall be minimized throughout the winter months. Windrows can distort traffic sounds used for *way-finding* by persons with vision loss

### APPLICATION

*Curb ramps* complying with this section shall be provided wherever any path of travel crosses a curb.

### DESIGN REQUIREMENTS

*Accessible curb ramps* shall be on an *accessible route* complying with Section 1.1.3 Accessible

Routes, Paths and Corridors. The *ramp slope* shall be between 1:50 and 1:20 (2%-5%).

The minimum width of *curb ramps*, exclusive of flared sides, shall be 1500 mm (59 in.), except where the alternate curb ramp configuration is used. The alternate curb ramp may have a reduced sidewalk width at the top of the curb ramp of 1220 mm (48 in.) for level maneuvering/turning space.

The lip or edge of the *curb ramp* shall not exceed 10 mm (3/8") and have a beveled or rounded edge of 5R (3/6"). Refer to Figure 2.1.5.6

*Curb ramp and sidewalk ramp* configuration and *truncated dome detectable warning* surfaces shall be installed as illustrated in Public Works Standard Detail SD-229 A to E and Standard Construction Specification CW 3326-R2.

*Truncated dome detectable warning surfaces in exterior curb ramps* shall be yellow in colour and shall be orientated perpendicular to the direction of the pedestrian crossing.

When used in an intersection, the *detectable warning* surface shall align directionally with the warning surface and curb ramp across the *street* to signify the start and end point of a travel way crossing.

The maximum crossfall of gutters and road surfaces immediately

adjacent to *curb ramps* shall be 1:20 (5%).

*Curb ramps* at pedestrian crosswalks shall be wholly contained within the area designated for pedestrian use.

Where possible provide dedicated area for snow piling from all *curb ramps*, away from pedestrian routes. Remove windrows from heavily travelled pedestrian routes.

When a conflict exists with either this standard or the standard construction specification please consult with the Public Works Engineer or Projects Manager.

### RELATED SECTIONS

- 1.1.1 Space and Reach Requirements
- 1.2.1 Texture, Finishes and Colour
- 1.2.6 Detectable Warning Surfaces
- 2.1.1 Exterior Ground Surfaces
- 2.1.3 Streetscape
- 3.1.1 Interior Floor Surfaces
- 3.5.4 Interior Glare and Light Sources



## 2.2.1 Balconies, Plazas and Patios

### RATIONALE

Where a number of balconies, patios or plazas are provided, it is desirable to consider options for different levels of sun and wind protection. This is of benefit to individuals with varying tolerances for sun or heat. Doors to these *spaces* typically incorporate large expanses of glazing. These should be appropriately marked to increase their visibility. Thresholds at balcony doors should be avoided.

### APPLICATION

Balconies, plazas and patios provided for use by the general public, clients, customers or employees shall comply with this section. See the Application Steps for a Sidewalk Patio at [http://www.winnipeg.ca/ppd/pdf\\_files/Brochures/Application-steps-for-a-sidewalk-patio.pdf](http://www.winnipeg.ca/ppd/pdf_files/Brochures/Application-steps-for-a-sidewalk-patio.pdf)

### DESIGN REQUIREMENTS

Balconies, patios and plazas shall:

- be located on an *accessible route* complying with Section 1.1.3 Accessible Routes, Paths and Corridors; and
- have a minimum depth of 2440 mm (96 in.).

Patios and plazas shall:

- not restrict the minimum *clear* width of adjacent sidewalks or other access routes. Refer

to Section 2.1.3 Streetscape and to the City of Winnipeg Encroachment ByLaw No. 692/94.

Exterior balconies, plazas and patios, where directly *accessible* from the interior *spaces*, shall incorporate a threshold in compliance with Section 3.5.1 Controls and Operating Mechanisms.

Balcony, plaza and patio surfaces shall:

- comply with Section 2.1.1 Exterior Ground Surfaces;
- be sloped to ensure removal of water; and
- be sloped no more than 1:50 (2%).

Railings and *guards* at balconies, plazas and patios shall:

- comply with the requirements of the *MBC*; and
- be designed to allow *clear* vision below the rail for persons seated in wheelchairs;
- incorporate pronounced *colour contrast* between the railings and *guards* from the surrounding environment; and
- where located adjacent to an *accessible route*, incorporate a *cane-detectable element*, no more than 100 mm (4 in.) above the surface of the *accessible route*. i.e. a fence with a bottom horizontal rail 4" above sidewalk level.

Where located adjacent to an *accessible route* patio umbrellas shall not overhang into the *accessible route*.

Doors opening out onto balconies or patios shall be located to open against a side wall or rail.

### RELATED SECTIONS

- 1.1.1 Space and Reach Requirements
- 1.1.3 Accessible Routes, Paths and Corridors
- 1.2.1 Texture, Finishes and Colour
- 2.1.1 Exterior Ground Surfaces
- 2.1.3 Streetscape
- 3.1.1 Interior Floor Surfaces

## 2.2 EXTERIOR AMENITIES

2.2.1 Balconies, Plazas and Patios (continued)

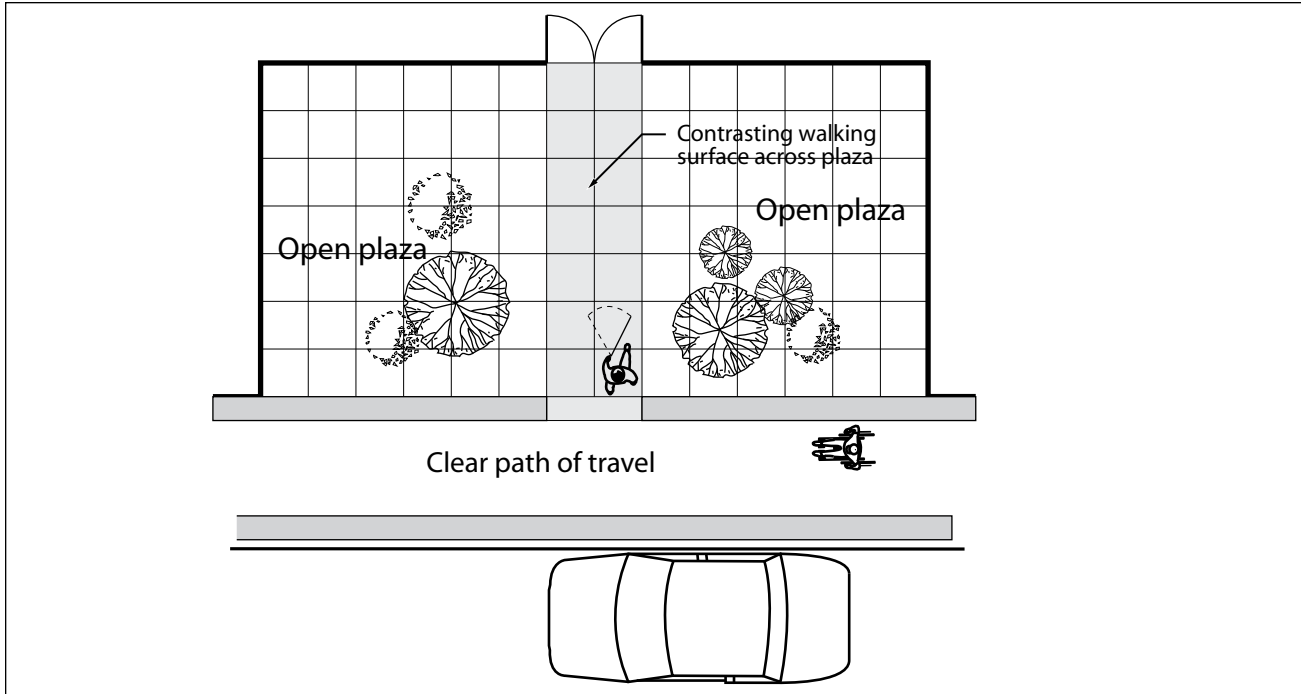

Figure 2.2.1.1 Pathway Across Open Plaza

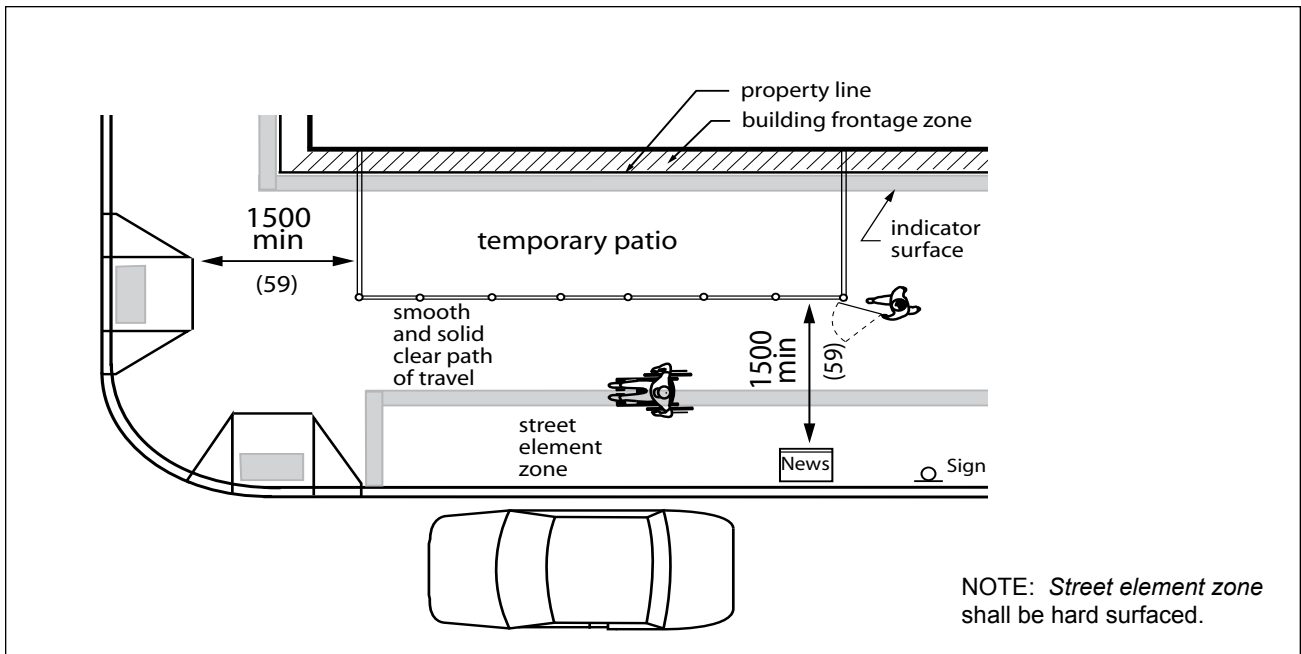
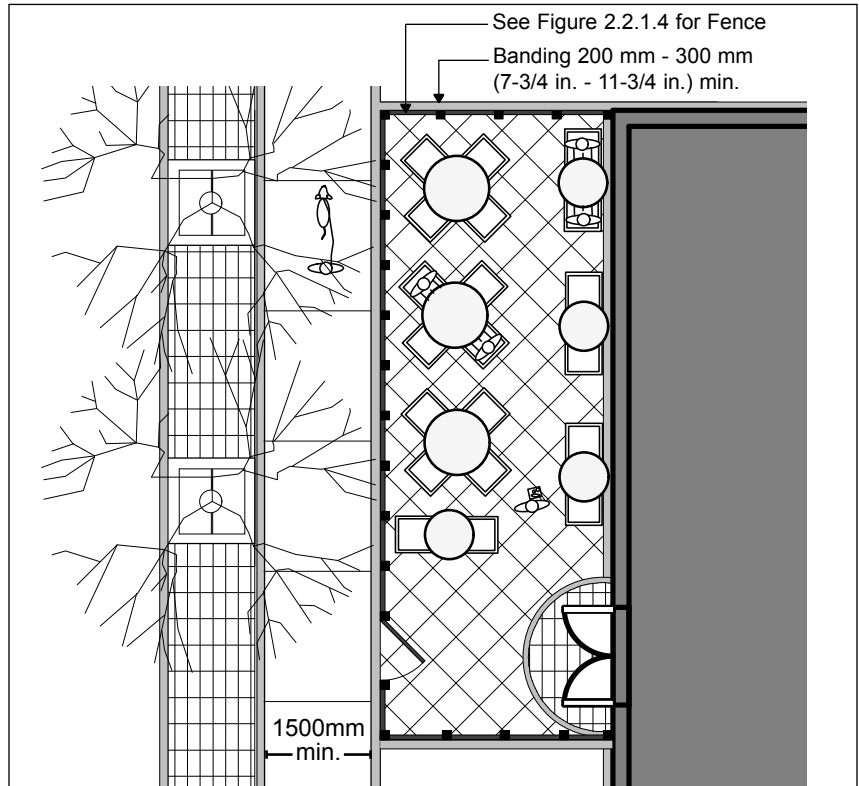
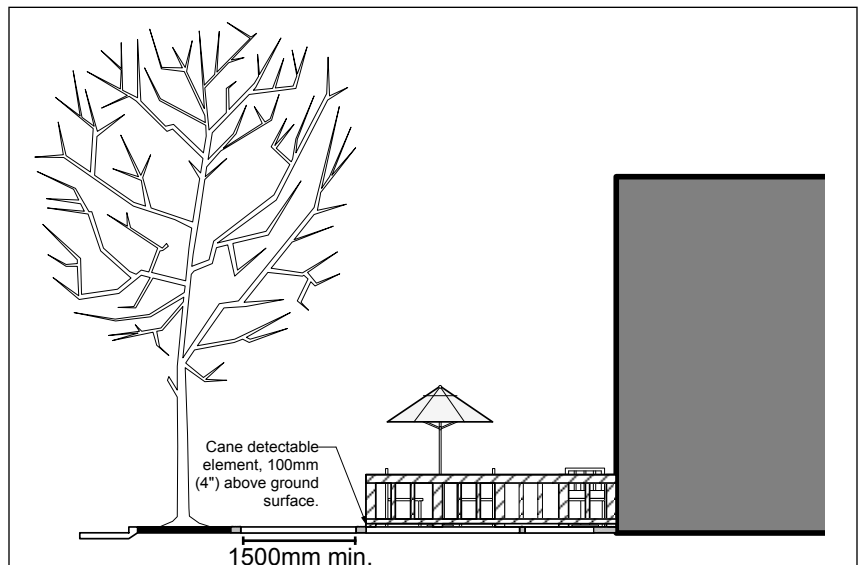

Figure 2.2.1.2 Temporary Patio in a Public Right-of-Way

2.2.1 Balconies, Plazas and Patios (continued)



**Figure 2.2.1.3** Permanent Patio in a *Public Right-of-Way*  
(downtown sidewalk width shall be min. 1900 mm (6' 2"))



**Figure 2.2.1.4** Temporary Patio in a *Public Right-of-Way*  
(downtown sidewalk width shall be min. 1900 mm (6' 2"))

2.2 EXTERIOR AMENITIES

## 2.2.2 Plantings

### RATIONALE

Trees, shrubs and other plants should be selected and located with a wide variety of users in mind. Fragrant plants can provide orientation cues for individuals with vision *impairments*. *Colour contrasting* plant material near walkways can be helpful as a guide. A row of hedges along one side of a walkway can provide edge definition and straight-line orientation for individuals with vision *impairments*.

Good maintenance of planting is as important as good design. Plants that drop large seeds and/or fruit can present slipping hazards, as well as difficulties for pushing a wheelchair. Plants that overhang pathways can impede all users and be a particular hazard to individuals with vision *impairments*.

### APPLICATION

Landscape *elements* and plantings beds contained within the *site* shall comply with this section.

Where plant beds or community gardens are provided for gardening use 10% of the area of the plant beds, but not less than one, shall comply with this section. It is preferable to have all plant beds comply with this section.

### DESIGN REQUIREMENTS

*Accessible* community gardens shall be:

- raised a minimum of 460 mm (18 in.) and a maximum of 865 mm (34 in.) above the adjacent floor or ground surface; and
- located on a solid surface adjacent to an *accessible route* complying with Section 1.1.3 Accessible Routes, Paths and Corridors.

Shrubs with thorns and sharp edges shall be maintained such that they do not encroach upon the *accessible route*.

Plants that drop large seeds and fruit such as apple trees, ornamental crab trees, and acorns from oak trees, shall not overhang or be positioned near *accessible* paths or walkways.

Guy wires shall not be used in any area which is intended for use by the general public, clients, customers or employees, unless the guy wires are protected by a *cane-detectable barrier*.

*Tree guards* shall conform to Sections 1.1.2 Protruding and Overhead Objects and 1.1.3 Accessible Routes, Paths and Corridors, and tree grates will conform to Section 2.1.1 Exterior Ground Surfaces.

Overhanging branches of trees or shrubs over walkways or paths shall not reduce the available headroom at any part of the *walkway* or path to less than 2500 mm (98 1/2 in.).

### RELATED SECTIONS

- 1.1.1 Space and Reach Requirements
- 1.1.2 Protruding and Overhead Objects
- 1.1.3 Accessible Routes, Paths and Corridors
- 1.2.1 Texture, Finishes and Colour
- 1.2.6 Detectable Warning Surfaces
- 2.1.1 Exterior Ground Surfaces
- 2.1.3 Streetscape
- 3.1.1 Interior Floor Surfaces

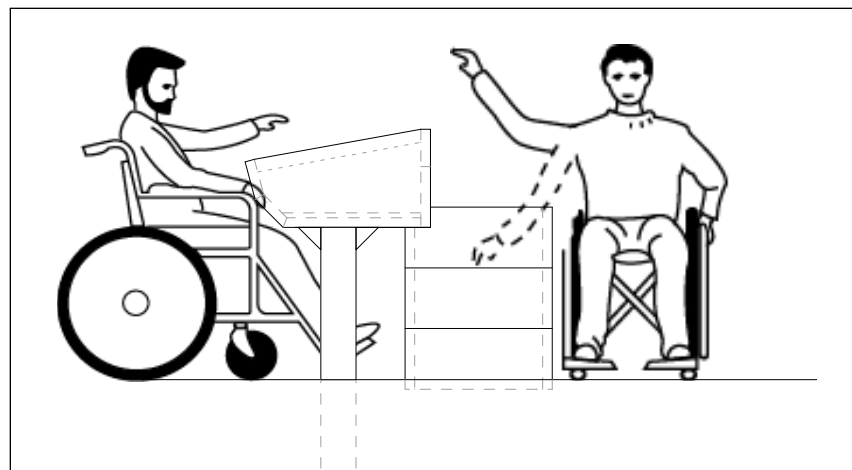

Figure 2.2.2.1 Example of an *Accessible* Planting Bed

2.2.3 Picnic Tables

RATIONALE

Picnic tables with an extension of the table surface make them *accessible* to persons using wheelchairs. A firm, level surface around the table, with an *accessible* path leading to the table, is required for wheelchair accessibility. A change in texture from a pathway to the picnic table area is an important cue for an individual with a vision *impairment*.

APPLICATION

If picnic tables are provided in an *accessible* public or *common use* area, at least 10%, but not less than one, for each cluster of picnic tables shall comply with this section. It is preferable to have all picnic tables comply with this section.

DESIGN REQUIREMENTS

*Accessible* picnic tables shall:

- be adjacent to an *accessible route* complying with Section 1.1.3 Accessible Routes, Paths and Corridors;
- have knee *space* under the table at least 760 mm (30 in.) wide by 500 mm (19 5/8 in.) deep and 700 mm (27 1/2 in.) high;
- be of contrasting colour to their background; and
- have a level, firm ground surface extending at least 2440 mm (96 in.) on two sides of the table and at least 1220 mm (48 in.) on the other sides.

The top of *accessible* picnic tables shall be from 710 mm (28 in.) to 850 mm (33 1/2 in.) above the finished floor or ground.

RELATED SECTIONS

- 1.1.1 Space and Reach Requirements
- 2.1.1 Exterior Ground Surfaces
- 3.1.1 Interior Floor Surfaces
- 1.1.2 Protruding and Overhead Objects
- 1.1.3 Accessible Routes, Paths and Corridors
- 2.1.3 Streetscape
- 1.2.6 Detectable Warning Surfaces
- 1.2.1 Texture, Finishes and Colour

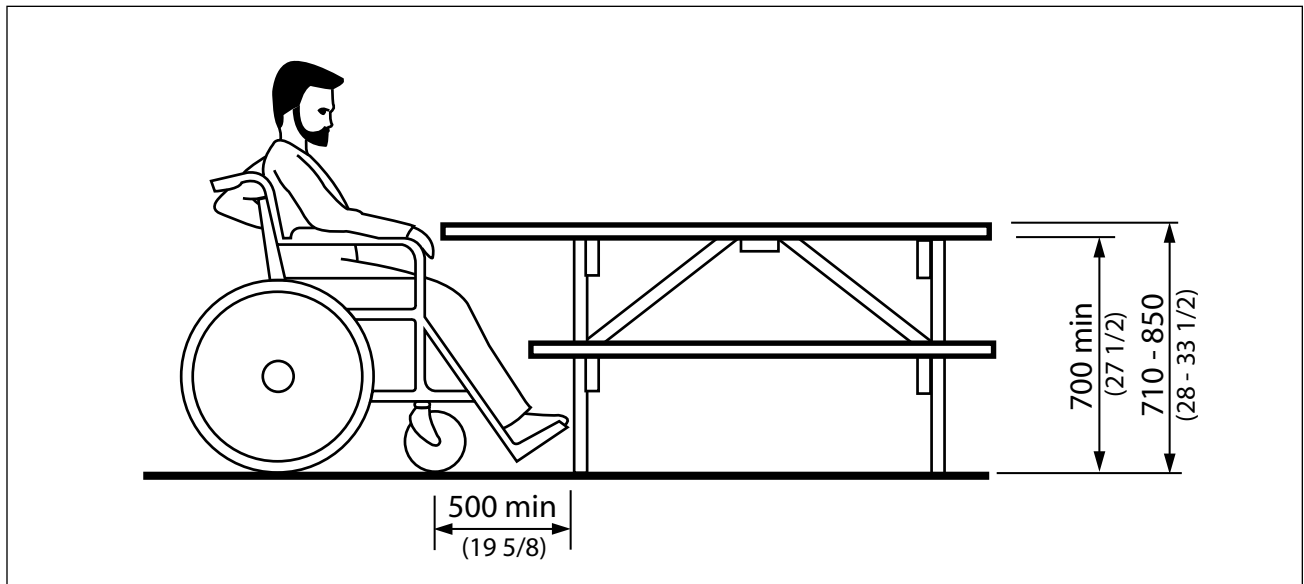

Figure 2.2.3.1 Picnic Table Requirements

2.2.3 Picnic Tables (continued)

RELATED SECTIONS

- 1.1.1 Space and Reach Requirements
- 1.1.2 Protruding and Overhead Objects
- 1.1.3 Accessible Routes, Paths and Corridors
- 1.2.1 Texture, Finishes and Colour
- 1.2.6 Detectable Warning Surfaces
- 2.1.1 Exterior Ground Surfaces
- 2.1.3 Streetscape

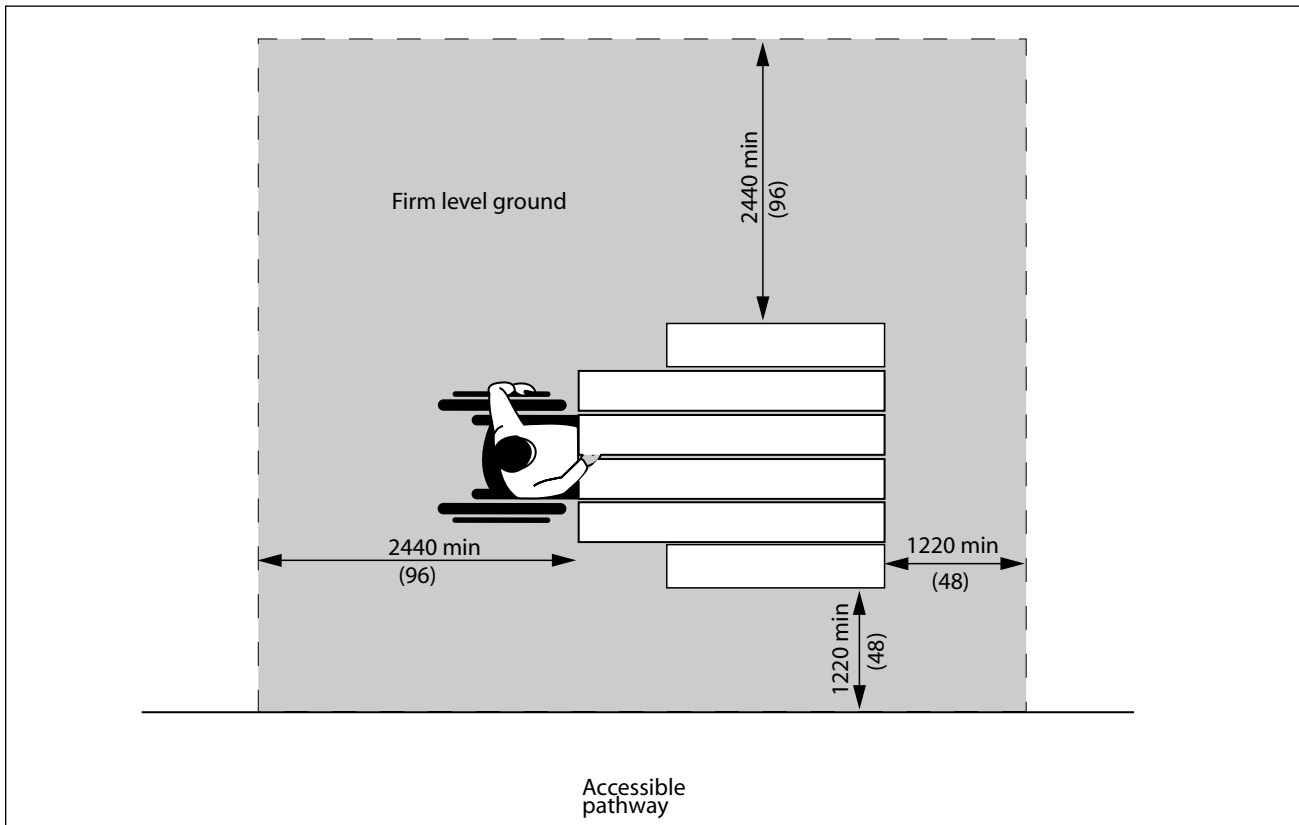

Figure 2.2.3.2 Space Requirements Around Picnic Tables



## 2.2.4 Dog Relief Areas

### RATIONALE

Persons who are vision impaired and use a dog to assist with mobility, as well as other persons with working companion dogs, require access to an area for their dogs to relieve themselves. Such dog relief areas need to be in an *accessible* location, feature good drainage and a garbage can for waste disposal.

### APPLICATION

Dog relief areas shall be provided in *buildings* of assembly occupancy which incorporate a meeting space for 50 or more people.

Dog relief areas shall comply with this section.

### DESIGN REQUIREMENTS

Dog relief areas shall:

- be adjacent to an *accessible route* complying with Section 1.1.3 Accessible Routes, Paths and Corridors;
- be located within 30 metres (98 ft. 5 in.) of an *accessible entrance*;
- be an unobstructed, dedicated space at least 1500 x 1500 mm (59 x 59 in.) in size;
- incorporate a ground surface with drainage (Note: grass is preferable to gravel);
- incorporate an accessible garbage can; and
- be located away from busy traffic areas such as access routes and patios.

### RELATED SECTIONS

- 1.1.3 Accessible Routes, Paths and Corridors
- 2.1.3 Streetscape

## 2.2 EXTERIOR AMENITIES

# EXTERIOR STANDARDS

## 2.3.1 Parking

### RATIONALE

The provision of parking *spaces* near the *entrance* to a facility either indoors or outdoors is important to accommodate persons with a variety of *disabilities*. *Disabling* conditions such as arthritis or heart conditions, using crutches or pushing a wheelchair, all make it difficult to travel long distances. Minimizing travel distances is particularly important outdoors where weather conditions and ground surfaces can make travel both difficult and hazardous. The *accessible route* of travel connecting the parking to the *entrance* should be well marked and free of steps and curbs.

In addition to the proximity to *entrances*, the spatial requirements of accessible parking *spaces* is important. A person using a mobility aid such as a wheelchair requires a wider parking stall to accommodate the maneuvering of the wheelchair beside the car or van. A van may also require additional *space* to deploy a lift or *ramp* through the side or back door. An individual would then require *space* for the deployment of the lift itself as well as additional *space* to maneuver on/off the lift.

Heights of ceilings or overhead structures along the routes to accessible parking are a factor. Accessible vans may incorporate a raised roof resulting in the need for additional overhead clearance. Alternatively, the floor of the van may be lowered, resulting in

lower tolerances for speed bumps and pavement slope transitions.

The number of *accessible parking spaces* required by this section may not be sufficient in some *facilities* (such as seniors' centres) where increased numbers of persons with *disabilities* might be expected.

### APPLICATION

This standard is applicable to all new parking structures, on and off-street parking and surface parking lots. For existing structures and surface parking lots undergoing renovations/*alterations*, standards should be employed whenever feasible.

The number of parking *spaces* designated to accommodate persons with disabilities shall be in accordance with Table 2.3.1.1.

All designated *spaces* shall be located on the shortest possible circulation route, with minimal traffic flow crossing, to an *accessible facility entrance* (e.g., in lots serving a particular *facility*) or to an *accessible pedestrian entrance* of the parking *facility* (e.g., in lots not serving a particular *facility*).

In *facilities* with multiple *accessible entrances* with adjacent parking, *accessible parking spaces* shall be dispersed and located closest to the *accessible entrances*.

### DESIGN REQUIREMENTS

An *accessible route* shall be

provided from each *accessible parking area* to an *accessible entrance* into the *facility*.

*Accessible off-street parking spaces* shall:

- be located on and have direct and unobstructed access to an *accessible route* complying with Section 1.1.3 Accessible Routes, Paths and Corridors;
- be at least 2440 mm (96 in.) wide and 6100 mm (240 in.) long;
- have an adjacent *access aisle* at least 2440 mm (96 in.) wide. In a *retrofit* situation where it is *technically not feasible* to provide a 2440 mm (96 in.) *access aisle*, the aisle may be reduced to 2000 mm (78-3/4 in.);
- have a firm, level surface with a maximum of 2% longitudinal grade for drainage;
- where surfaces are paved, have *access aisles* clearly indicated by markings. Refer to Figures;
- have a maximum *cross slope* of 1:50 (2%); and
- have a height clearance of at least 2500 mm (98 in.) at the parking *space* and along the vehicle access and egress routes.

*Accessible on-street parking spaces* shall:

- be located on an *accessible route* complying with Section 1.1.3 Accessible Routes, Paths and Corridors;

## 2.3 EXTERIOR CONTEXT SPECIFIC REQUIREMENTS

2.3.1 Parking (continued)

- be at least 3900 mm (154 in.) wide and 5400 mm (213 in.) long;
  - have an *access aisle* behind the vehicle at least 2440 mm (96 in.) wide. In a *retrofit* situation where it is *technically not feasible* to provide a 2440 mm (96 in.) *access aisle*, the aisle may be reduced to 2000 mm (78-3/4 in.);
  - provide a curb ramp to access the sidewalk proximate to the parking stall
  - have an adjacent clear space crossing the *street element zone* at least 2440 mm (96 in.) wide leading to the accessible route;
  - have a firm, level surface;
  - have a maximum *cross slope* of 2%; and
  - have a height clearance of at least 2750 mm (9 ft.) at the parking *space* and along the vehicle access and *egress* routes.
- Accessible parking spaces* shall be designated as being reserved for use by persons with *disabilities*.
- Signage* of parking *spaces* shall incorporate the following components:
- a designated *disabled* parking

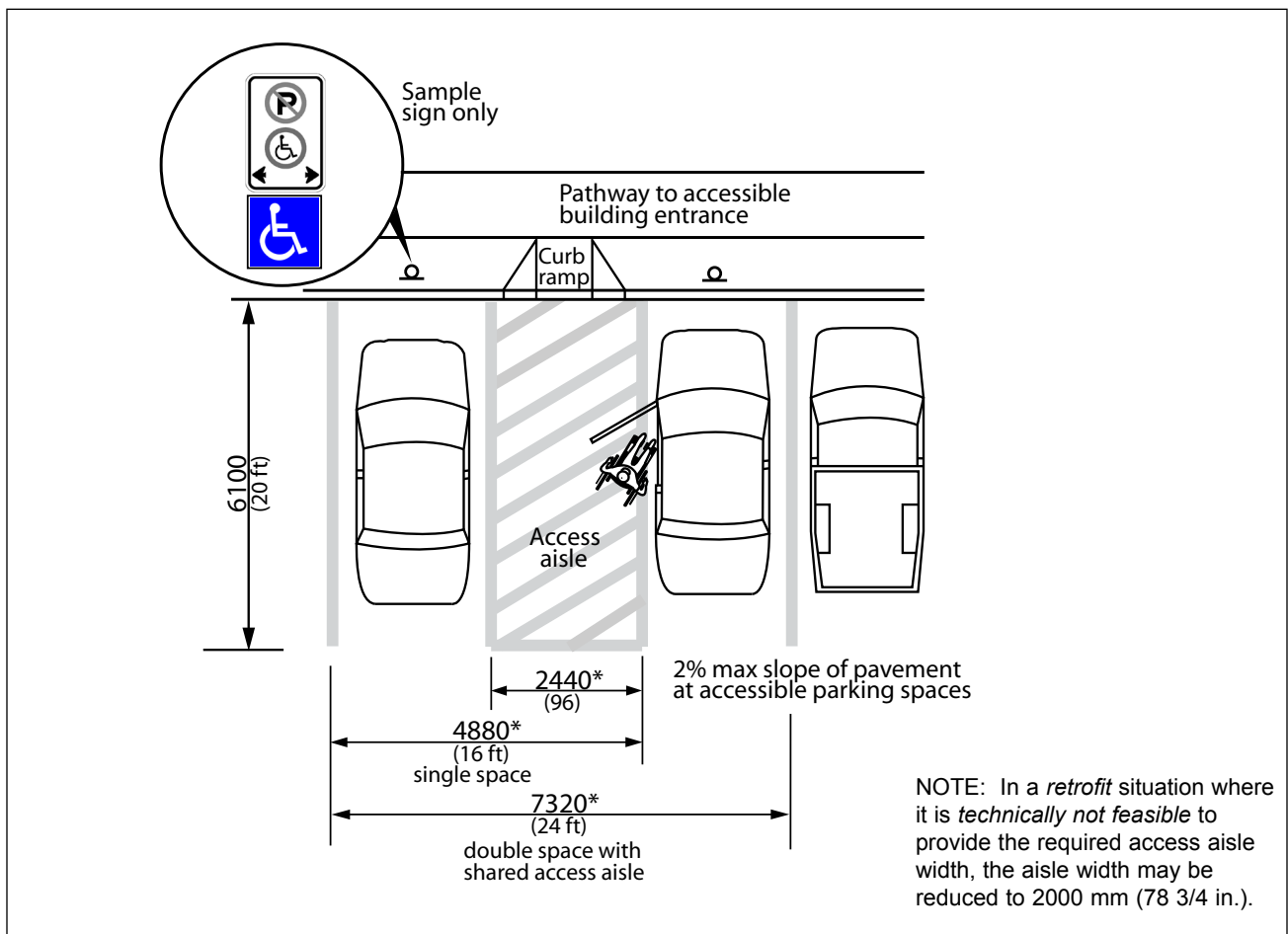

Figure 2.3.1.1 Side-by-side Parking Space

2.3 EXTERIOR CONTEXT SPECIFIC REQUIREMENTS

# EXTERIOR STANDARDS

## 2.3.1 Parking (continued)

space sign as specified in the 'Manual of Uniform Traffic Control Devices for Canada', mounted vertically; and

- for off-street parking, an international symbol of access on a vertical sign at the head of the parking stall and painted on the horizontal surface of the stall.

Required vertical parking space designation signs shall:

- be at least 300 mm (12 in.) wide x 450 mm (18 in.) high; and
- be installed at a height of 2000 mm (78 in.) to 3000 mm (118 in.) from the ground/floor surface to the centre line of the sign.

The symbol of access shall be permanently marked or painted on the pavement of each designated off-street parking space and shall:

- be at least 1000 mm (3'-4") long;
- be located in the centre of the space; and
- be painted white on a background field of blue.
- Paint used on the surface of parking spaces must be slip-resistant.

In multi-level parking facilities, signs must be provided indicating the floors that have accessible parking.

### RELATED SECTIONS

- 1.1.1 Space and Reach Requirements
- 1.1.2 Protruding and Overhead Objects
- 1.1.3 Accessible Routes, Paths and Corridors
- 1.2.1 Texture, Finishes and Colour
- 1.2.4 Signage
- 1.2.6 Detectable Warning Surfaces
- 1.3.2 Vending and Ticketing Machines
- 2.1.1 Exterior Ground Surfaces
- 2.1.2 Exterior Lighting
- 2.1.3 Streetscape
- 3.1.1 Interior Floor Surfaces
- 2.1.5 Curb Ramps and Truncated Dome Detectable Warning Surfaces
- 3.5.3 Interior Lighting

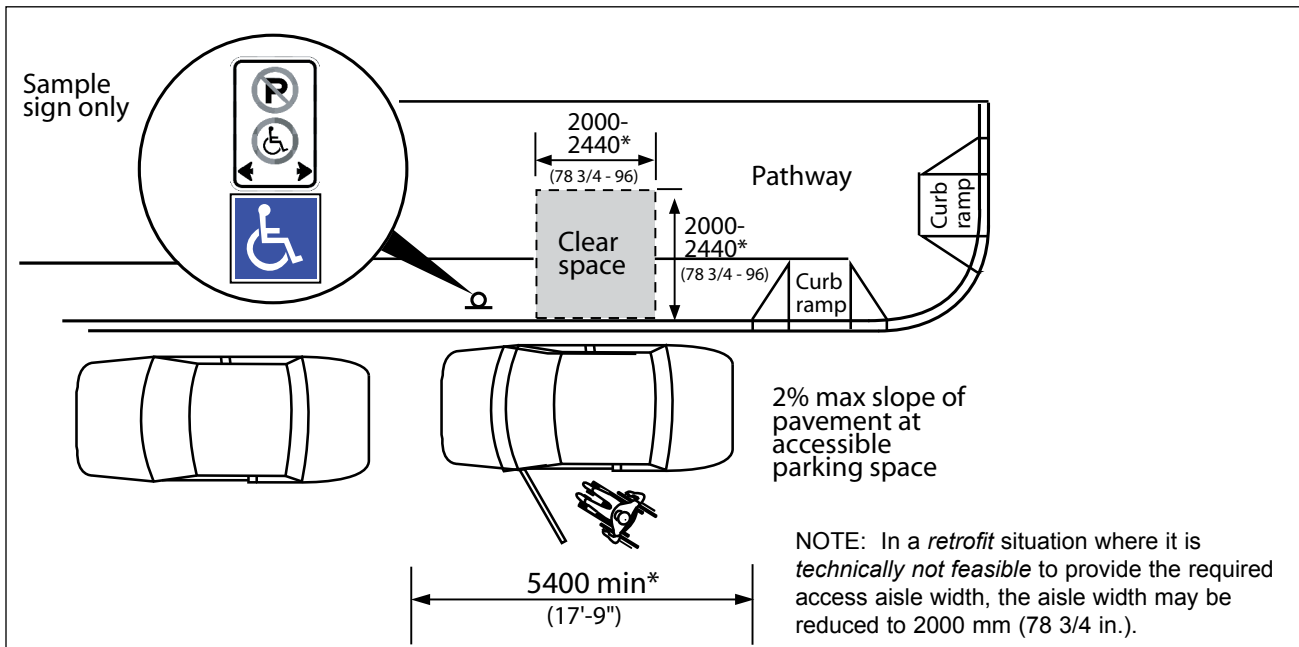

Figure 2.3.1.2 Parallel Parking Space

## 2.3 EXTERIOR CONTEXT SPECIFIC REQUIREMENTS

2.3.1 Parking (continued)

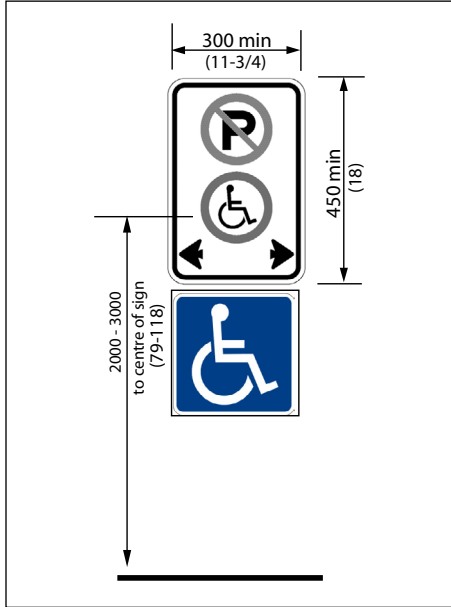

Figure 2.3.1.3 Parking Sign (Sample Sign Only)

Total Required Parking Spaces	Minimum Number of Accessible Parking Spaces Required	Minimum Number of Van Accessible Parking Spaces Required
2 to 25	1	0
26 to 50	2	1
51 to 75	3	1
76 to 100	4	2
101 to 150	5	2
151 to 200	6	2
201 to 300	7	2
301 to 400	8	3
401 to 500	9	3
501 to 1,000	2 percent of total	4
1,001 to over	20, plus 1 for each 100 over 1,000	4 plus 1 for each 100 over 1,000

Table 2.3.1.1 Accessible Parking Space Allocation

2.3 EXTERIOR CONTEXT SPECIFIC REQUIREMENTS

# EXTERIOR STANDARDS

## 2.3.2 Passenger Loading Zones

### RATIONALE

Passenger loading zones are important features for individuals who may have difficulty walking distances or those who use parallel transit systems. *Accessible* transit vehicles typically require *space* for the deployment of lifts or *ramps* and overhead clearances. Protection from the *elements* will be beneficial to all users and particularly those that may have difficulty with mobility.

It is beneficial to provide interior and exterior waiting areas adjacent to passenger loading zones, preferably with *clear* sight lines to approaching vehicles.

### APPLICATION

*Accessible* passenger loading zones shall be identified with *signage* complying with 'Provincial Highway Traffic Act' loading zone signage.

Where passenger loading zones are provided, at least one shall comply with this section.

If the passenger loading zone is a designated Handi-Transit stop zone, it shall comply with all relevant municipal bylaws.

### DESIGN REQUIREMENTS

Passenger loading zones shall:

- be on an *accessible route* complying with Section 1.1.3 Accessible Routes, Paths and Corridors;
- provide an *access aisle* at least 2000 mm (78-3/4 in.) wide and 7000 mm (23 ft.) long, adjacent and parallel to the vehicle pull-up *space*;
- have a *curb ramp* complying with 2.1.5 where there are curbs between the *access aisle* and the vehicle pull-up *space*; and
- have a minimum vertical clearance of 3600 mm (11 ft. - 10 in.) at the loading zone and along the vehicle access route to such areas to and from the *site entrances*.

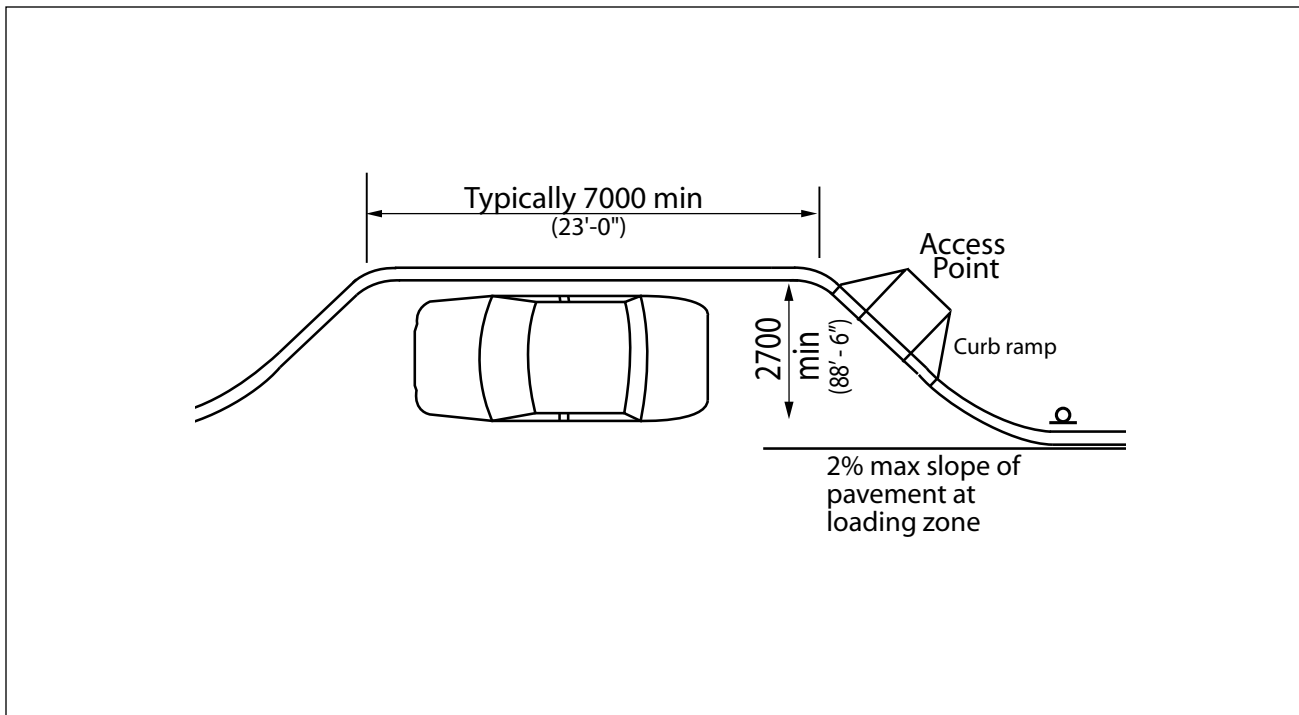

Figure 2.3.2.1 Off-Street Lay-by Passenger Loading Zone

2.3.2 Passenger Loading Zones (continued)

RELATED SECTIONS

- 1.1.1 Space and Reach Requirements
- 1.1.2 Protruding and Overhead Objects
- 1.1.3 Accessible Routes, Paths and Corridors
- 1.2.1 Texture, Finishes and Colour
- 1.2.4 Signage
- 1.2.6 Detectable Warning Surfaces
- 2.1.1 Exterior Ground Surfaces
- 2.1.2 Exterior Lighting
- 2.1.3 Streetscape
- 2.1.5 Curb Ramps and Truncated Dome Detectable Warning Surfaces

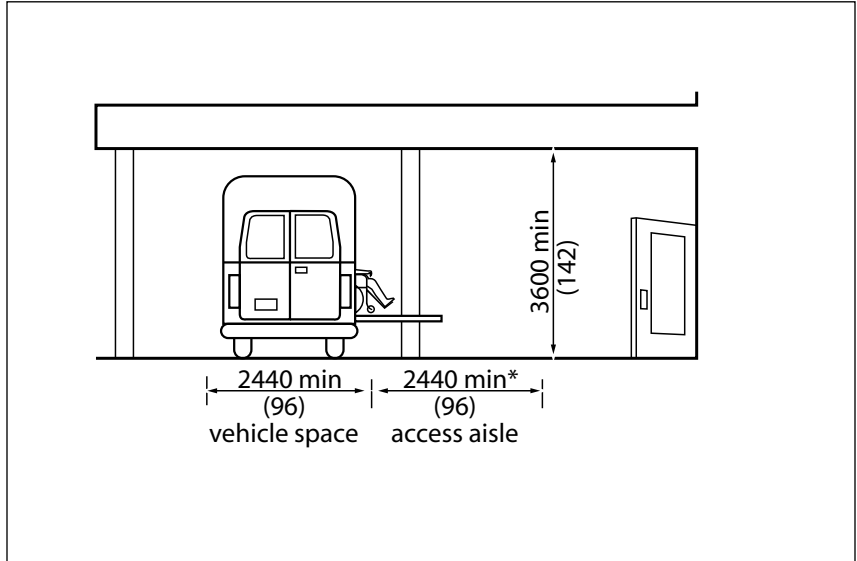

Figure 2.3.2.2 Height Clearances at Passenger Loading Zone

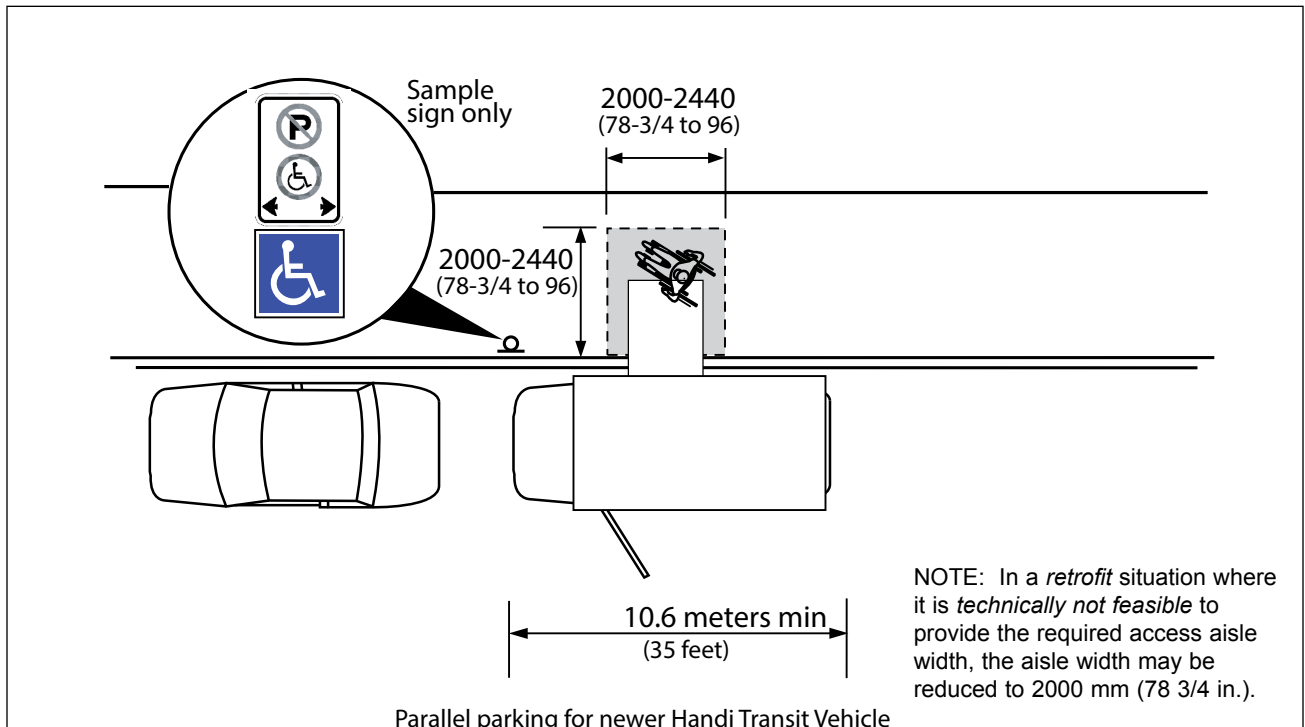

Figure 2.3.2.3 On-Street Passenger Loading Zone

2.3 EXTERIOR CONTEXT SPECIFIC REQUIREMENTS

## 2.3.3 Outdoor Recreational Facilities

### RATIONALE

Opportunities for recreation, leisure and active sport participation should be available to all members of the community. Access should be provided to playing fields and other sports *facilities*, including access to the *site*, all activity areas, outdoor trails, docks, swimming areas, play *spaces*, lockers, change rooms and showers.

### APPLICATION

In addition to the design requirements specified in Sections 1.0 General Design Standards, 2.0 Exterior Design Standards and 3.0 Interior Design Standards, the outdoor recreation *facilities* listed below shall comply with this section.

Where dressing *facilities* are provided for use by the general public, clients, customers, performers or staff, at least 50%, but never less than one, for each type of use in each cluster of dressing *facilities* shall be *accessible* and in compliance with Section 3.2.6 Specialty Change Rooms. It is preferable to have all dressing *facilities accessible*.

All waste receptacles, except those located in unpaved areas of *parks*, wilderness, beach or picnic areas, shall be *accessible* to persons using wheelchairs or other mobility devices.

### DESIGN REQUIREMENTS

#### General

*Parks* accessibility shall encompass the development of *active transportation routes*, auxiliary services, planting and an overall environment which is *accessible* and provides a fulfilling recreational experience.

#### ACTIVE TRANSPORTATION ROUTES

The principal consideration when planning for, designing and siting new active transportation routes is the need of pedestrians. Because of the inherent conflict between bicycles and pedestrians, the primary aim of designing any recreational pathway is complete separation of conflicting uses.

This can be achieved by

- providing for bicyclists on the *street right-of-way*;
- providing a continuous physical *barrier* between paths for bicyclists and pedestrians, such as railings, planting strips or a level difference between the bicycle path and the footpath.

Where pedestrians, bicycle and vehicular paths of travel cross or converge, pedestrians tend to be most vulnerable. Therefore, giving priority consideration to pedestrian needs in these instances is extremely important.

#### Boardwalks

Where boardwalks are provided, they shall

- have a minimum width of 2440 mm (96 in.);
- incorporate surfaces constructed of firm, non-slip materials. Where wooden planks are used, they shall be laid perpendicular to the path of travel and have joints no greater than 6 mm (1/4 in.);
- incorporate a continuous upstand edge where the grade drop-off on any side of the boardwalk is greater than 200 mm (7-7/8 in.). The upstand edge shall be at least 100 mm (4 in.) high and of a contrasting colour to the surrounding terrain;
- have *handrails*, *guards* or other suitable *barriers* on both sides where the grade drop-off is greater than 76 mm (3 in.) and within 610 mm (24 in.) from any walking surface edge. Refer to Figure 1.1.3.1 in Section 1.1.3 Accessible Routes, Paths and Corridors;
- incorporate level access points to the boardwalk from *accessible* routes; and
- where benches, waste receptacles, drinking fountains, etc., are provided, they shall be located adjacent to the boardwalk on firm, level surfaces at the same elevation as the boardwalk. Refer to Section 2.1.3 Streetscape.



## 2.3.3 Outdoor Recreational Facilities (continued)

### Footbridges, Steps and Ramps

Where significant changes in grade occur, trail routes (including bridges) shall ideally be sloped at no greater than 1:20 (5%), or have adjacent steps and *ramps*. If trail routes are sloped steeper than 1:20 (5%), alternate routes shall be provided.

Where steps, footbridges or *ramps* are used, the surfacing shall be of non-slip materials and include suitable *colour contrasting handrails* and/or *guards*. Refer to Sections 1.1.5 Ramps, 1.1.6 Stairs and 1.1.7 Handrails and Guards.

### Pathways and Greenways

All pathways and greenways shall be designed and constructed to be *accessible routes* and walkways and shall conform with Section 1.1.3 Accessible Routes, Paths and Corridors.

Waste receptacles, light standards, benches and other potential obstructions shall be located so as not to obstruct the *accessible route*. Refer to Section 2.1.3 Streetscape.

A different ground colour and/or texture shall be used to indicate the following

- risk areas, such as intersections, *ramps* or steps;
- functional changes, such as seating areas, viewpoints or outlooks. Refer to Section 1.2.1 Texture, Finishes and Colour; and
- vertical elements that are not

*cane detectable*. Refer to Section 1.1.2 Protruding and Overhead Objects.

- where there is no other proximate light source present, a pedestrian scale lighting source must be provided at the pathway or greenway
- where a clear definition of cycling and pedestrian use space is required (i.e. transit stops)

### Bicycle Pathways

These pathways are physically separated from motor vehicle traffic and from sidewalks or pedestrian pathways, and are reserved for use by bicycles and other types of wheeled vehicles (in-line skates, scooters, wheel-chairs, etc.).

Access points to bicycle pathways shall be designed to avoid mistaken use of facility by pedestrians.

### Trails

When not paved, the use of hard-packed granular is accepted. For specific details contact the design branch of the City of Winnipeg Planning and Land Use Department.

### Multi-Use or Shared Use Pathways

Where there is a high likelihood of pedestrian/cyclist interaction, separated pedestrian/cycling facilities are required. (i.e. bus routes).

Only where there is insufficient space to accommodate separate pedestrian and bicycle pathways a *multi-use pathway* may be considered.

Education about sharing space is highly recommended for all user groups.

Where a *multi-use pathway* must be used, separation shall be achieved through the use of a central colour contrasted band to delineate direction of travel.

Detectable warning tiles shall be used in accordance with the Public Works Standard Construction Specification

## AMENITIES

### Planting and Trees

Planting and trees along *accessible* pathways shall comply with Section 2.2.2 Plantings.

### Rest Areas

Rest areas shall

- be provided on trails, pathways and walkways;
- be positioned adjacent to the trail, pathway or walkway;
- have *accessible* ground surfaces in compliance with Section 2.1.1 Exterior Ground Surfaces;
- use a contrasting ground finish material to identify functional change; and
- incorporate at least one bench, in compliance with Section 1.3.6 Seating.

## 2.3 EXTERIOR CONTEXT SPECIFIC REQUIREMENTS

# EXTERIOR STANDARDS

## 2.3.3 Outdoor Recreational Facilities (continued)

### Parks, Parkettes and Play-grounds

*Entrance* gates, paths and walkways throughout the *park* shall be *accessible* to persons using wheelchairs or scooters and meet the requirements of applicable parts of Section 1.0 and 2.0.

Picnic and play areas shall be provided in both sunny and shaded areas.

### Outdoor Pools and Spray Pads

Outdoor swimming pools and spray pads shall comply with Section 1.4.1 Water Facilities.

### Picnic Tables

*Accessible* picnic tables shall comply with Section 2.2.3 Picnic Tables.

Where public parking is provided to serve picnic *facilities*, *accessible* picnic areas shall be within 30 meters (100 ft.) of the *accessible* parking *spaces*.

### Docks

Where docks for fishing, boating, water-taxi or swimming are provided they shall:

- be located on an *accessible route* in compliance with Section 1.1.3 Accessible Routes, Paths and Corridors;

- incorporate smooth and stable surfaces at transition points (such as from a walkway to a dock, or between adjacent dock units);
- incorporate clearly painted markings at transition points;
- where changes in elevation are necessary, incorporate *ramps* or *curb ramps* in compliance with Sections 1.1.5 Ramps and 3.1.4 Windows, Glazed Screens and Side-lights. *Ramps* with a slope no greater than 1:12 (8.3%) at low water are acceptable;
- be no higher than 600 mm (23-3/4 in.) above the water;
- incorporate a continuous upstand edge, at least 100 mm (4 in.) high and of a contrasting colour.
- Exception: Where boat loading openings are provided; incorporate a *guard* where dock surfaces are greater than 450 mm (17-3/4 in.) above the surface of the water; and
- where steps are provided to access the water for swimming, incorporate *colour contrasting handrails* at the steps. Such *handrails* shall extend to a minimum of 600 mm (23-5/8 in.) above the dock surface and return down to the dock.

### Drinking Fountains

*Accessible* drinking fountains shall comply with Section 1.3.1 Drinking Fountains.

### Illumination

Illumination levels shall:

- be a minimum of 10 lux (1 ft-candle);
- be maintained at 5 lux (0.5 ft-candles) in areas of heavy trees and shrubbery; and
- be maintained at 5 lux (0.5 ft-candles) in all other areas of *park* at ground level.

Light sources used shall be indirect, non-glare, non-flickering type and provide even levels of light distribution. Refer to Section 2.1.2 Exterior Lighting.

### Washrooms

Where washrooms are provided, they shall conform with Section 3.3.1 Toilet Facilities.

### Waterfront Areas

Where paths and/or lookout points are provided, they shall be *accessible* to all individuals.

Seating shall be provided along paths and at lookout points, in compliance with Section 1.3.6 Seating.

Where parking is provided, it shall be located as close as possible to key points of attraction. An *accessible route* shall be provided from the parking area to paths and/or lookout points (where provided).

2.3.3 Outdoor Recreational Facilities (continued)

Natural Areas

Accessible pathways, trails and footbridges shall be provided where environmental considerations will permit.

Paths and trails shall incorporate rest areas with appropriate seating in accordance with Section 1.3.6 Seating.

Where special lookout locations or wildlife viewing areas are provided, they shall be identified with *clear signage*.

Trails shall feature a *tactile* map at the start of the trail and periodically along its length that shall

- have the critical trail features embossed; and
- important text in raised lettering and Grade 1 uncontracted Braille.

Playing Fields and Spectator Areas

Controlled access points shall be designed to accommodate persons using wheelchairs. (e.g., Where turnstiles are used, an adjacent *accessible* gate shall be provided in accordance with Section 1.1.4 Gates, Turnstiles & Openings).

Level seating areas shall be provided beside sports fields for spectators or participants with *disabilities*.

Where provided, public viewing areas shall comply with Section 1.3.3 Elevated Areas and Platforms.

Where provided, public washrooms shall comply with Section 3.3.1 Toilets and Bathing Facilities.

RELATED SECTIONS

All relevant parts of Sections 1.0 General Design Standards, 2.0 Exterior Design Standards and 3.0 Interior Design Standards.

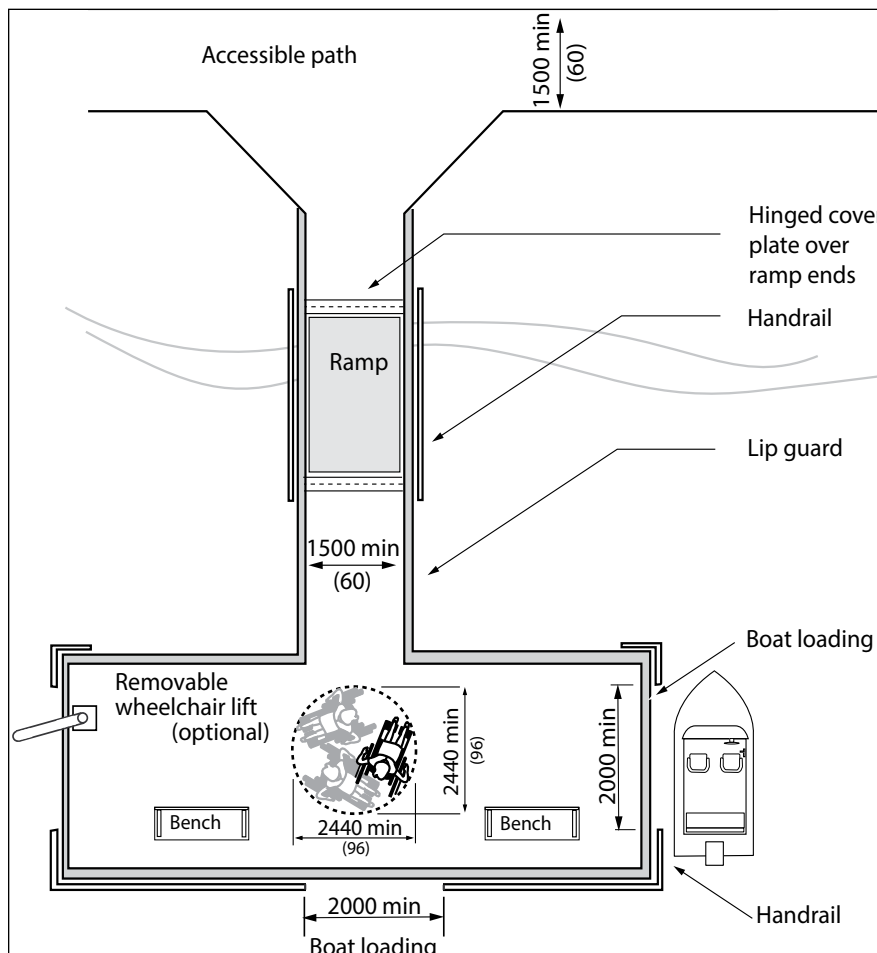

Figure 2.3.3.1 Accessible Dock

# EXTERIOR STANDARDS

## 2.3.4 Transit Facilities

### RATIONALE

Links to public transportation should be *accessible* to all members of a community.

Multiple formats of presenting scheduling information should be available (ie. electronic, audible, tactile, visual, etc.) wherever possible.

A large, consistently designed bus stop platform that is clear of obstacles is required where *accessible* buses are used or where a large number of passengers are expected to congregate between bus arrivals. The large platform will accommodate the deploying (lowering) of a wheelchair *ramp* from a bus and to allow for wheelchair movement on and off the *ramp*, as well as alighting from the rear door.

If not properly placed and maintained, *street* furniture such as trees, newspaper boxes, waste and recycling receptacles can restrict access to bus stops.

### APPLICATION

In addition to the design requirements specified in Sections 1.0 General Design Standards, 2.0 Exterior Design Standards and 3.0 Interior Design Standards, transportation *facilities* located within a *site* shall comply with this section.

### DESIGN REQUIREMENTS

#### Bus Stop Platforms

Bus stop platforms shall:

- be a minimum of 14,500 mm (47.5 ft.). Where it is technically not feasible to achieve that size, allow the platform to be reduced to a minimum of 8,500 mm long X 2,100 mm wide.
- be located on or immediately adjacent to an *accessible route* in compliance with Section 1.1.3 Accessible Routes, Paths and Corridors;
- be *clear* of all obstacles (including trees, bike racks, newspaper boxes, waste and recycling receptacles); and
- maintain clearances as specified in Section 1.1.2 Protruding and Overhead Objects.

Where there is no *accessible* route from the sidewalk to the bus stop platform, two paved connections from the sidewalk to the platform shall be provided which:

- are aligned with the edge of the platform;
- are at least 1500 mm (47 in.) wide;
- incorporate ground surfaces that comply with Section 2.1.1 Exterior Ground Surfaces;
- are *clear* of all obstacles (including trees, newspaper boxes, waste and recycling receptacles); and
- maintain clearance as specified in Section 1.1.2 Protruding and Overhead Objects.
- where feasible, include power door operators where there are doors on the shelter.

#### Bus Passenger Shelters

Bus passenger shelters shall:

- be located on an *accessible route* in compliance with Section 1.1.3 Accessible Routes, Paths and Corridors;
- provide a *clear* view of oncoming traffic;
- be located on firm, level pads approximately at the same elevation as the sidewalk or walkway;
- incorporate access openings at least 950 mm (37-1/2 in.) wide;
- incorporate *clear space* in compliance with Figure 1.1.1.6 *Clear Space* for Wheelchair;
- where glazed, incorporate a continuous horizontal safety strip decal which are a minimum 75 of mm (3 in.) wide, *colour contrasting*; and located 1400 - 1600 mm (55 - 63 in.) above ground level;
- where frameless glass is used adjacent to an access opening, incorporate a vertical *colour contrasting* safety stripe, applied to cap the end of the glass panel; and
- feature at least one seat with armrests and a seat height between 400 mm and 450 mm (15-3/4 in. and 17-3/4 in.).

### RELATED SECTIONS

All relevant parts of Sections 1.0 General Design Standards, 2.0 Exterior Design Standards and 3.0 Interior Design Standards.

## 2.3 EXTERIOR CONTEXT SPECIFIC REQUIREMENTS

2.3.4 Transit Facilities (continued)

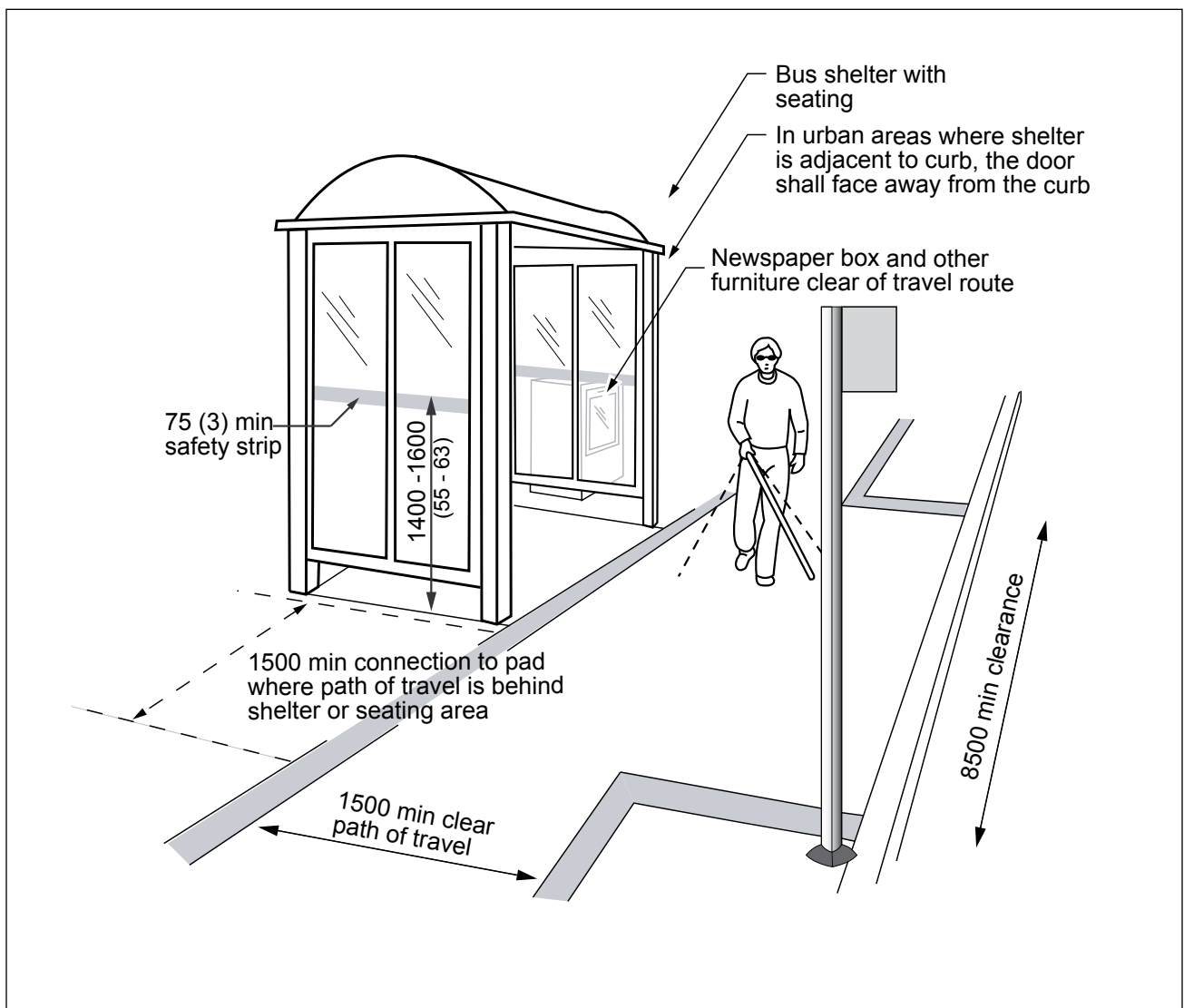

Figure 2.3.4.1 Bus Stop Platform with Shelter

2.3 EXTERIOR CONTEXT SPECIFIC REQUIREMENTS

2.3.4 Transit Facilities (continued)

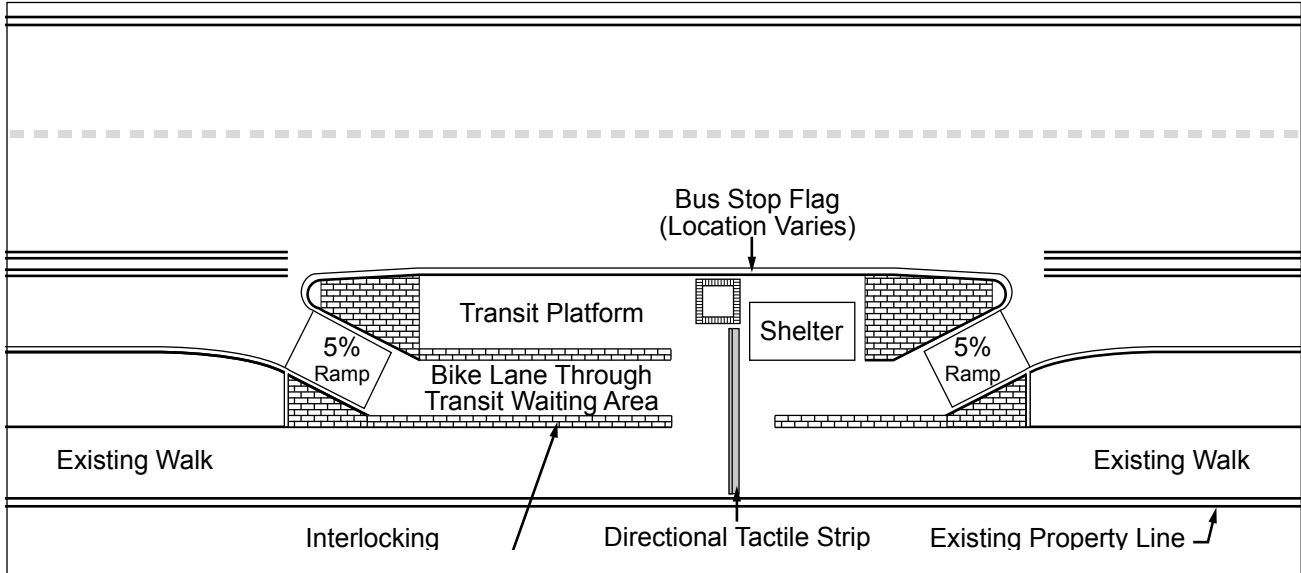

Figure 2.3.4.2 Typical Buffered Bike Lane Bus Stop Design

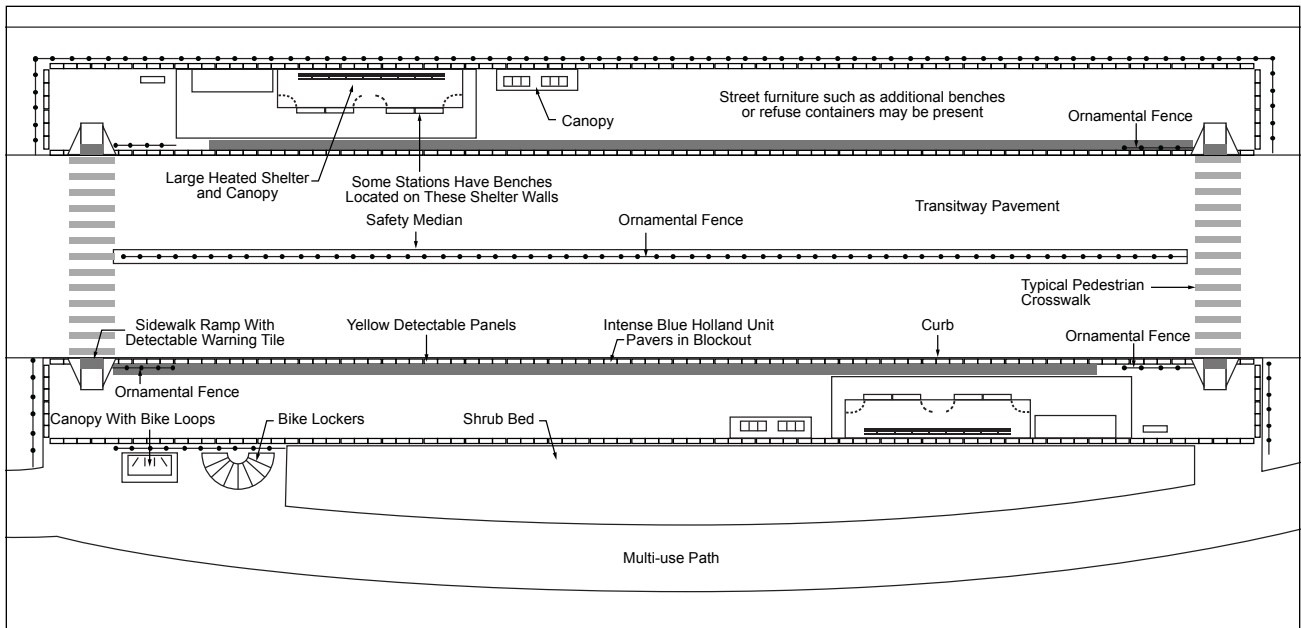

Figure 2.3.4.3 Typical Bus Rapid Transit Stop

### 2.3.5 Play Areas (continued)

#### RATIONALE

Children require access to play facilities to provide opportunities for the development of motor and cognitive skills, as well as opportunities for interaction and the development of socialization skills.

The integration of universally *accessible* play features within all play areas will benefit both caregivers and children with *disabilities*.

#### APPLICATION

Newly designed and newly constructed play areas for children ages 2 and over and altered portions of existing play areas shall comply with this section.

Ground level play components shall be provided in the numbers and types required in Table 2.3.5.2 and elsewhere in this section.

Where ground level play components are provided, at least one of each type provided shall be located on an *accessible* route in compliance with the design requirements of this section.

Where elevated play components are provided, ground level play components shall be provided in accordance with Table 2.3.5.2. Such ground level play components shall be located on an *accessible* route in compliance with the design requirements of this section.

Exception: Where at least 50% of the elevated play components are connected by a *ramp*, and if at least 3 of the elevated play components connected by the *ramp* are different types of play components.

Where elevated play components are provided:

- at least 50% shall be located on an *accessible* route complying with the design requirements of this section; and
- where the elevated play components are connected by a *ramp*, the *ramp* shall comply with the design requirements of this section.

Exception: *Transfer systems* complying with the design requirements of this section are permitted to connect elevated play components, except where 20 or more elevated play components are provided, no more than 25% of the elevated play components shall be permitted to be connected by transfer systems. Refer to Table 2.3.5.1.

Access routes within the boundary of a play area shall connect:

- ground level play components; and
- entry and exit points of the play components.

Where transfer systems are provided, an elevated play component shall be permitted to connect to another elevated play component, in lieu of an *acces-*

*sible* route.

The *clear* width of access routes within play areas shall comply with the design requirements of this section.

#### DESIGN REQUIREMENTS

Play areas shall comply with the latest edition of 'CAN/CSA-Z614 - Children's Playspaces and Equipment'.

Swings shall be placed away from other play areas and should be delineated by ground surfaces that feature colour and texture contrast.

Borders around play areas must incorporate an access point where accessible play components have been provided.

#### RELATED SECTIONS

All relevant parts of Sections 1.0 General Design Standards, 2.0 Exterior Design Standards and 3.0 Interior Design Standards.

## 2.3 EXTERIOR CONTEXT SPECIFIC REQUIREMENTS

# EXTERIOR STANDARDS

## 2.3.5 Play Areas

Elevated Play Components		
Total Provided	Ramped Access	Ramp or Transfer System Access
Less than 20	not required	50% minimum
20 or more	25% minimum	25% minimum

**Table 2.3.5.1** Access to Elevated Play Components

Number of Elevated Play Components Provided	Minimum Number of Ground Level Play Components Required to be on an Accessible Route	Minimum number of Different Types of Ground Level Play Components Required to be on an Accessible Route
1	Not Applicable	Not Applicable
2 to 4	1	1
5 to 7	2	2
8 to 10	3	3
11 to 13	4	3
14 to 16	5	3
17 to 19	6	3
20 to 22	7	4
23 to 25	8	4
More than 25	8 plus 1 for each additional three over 25, or part thereof	5

**Table 2.3.5.2** The Number and Types of Ground Level Play Components Required to be on an *Accessible Route*



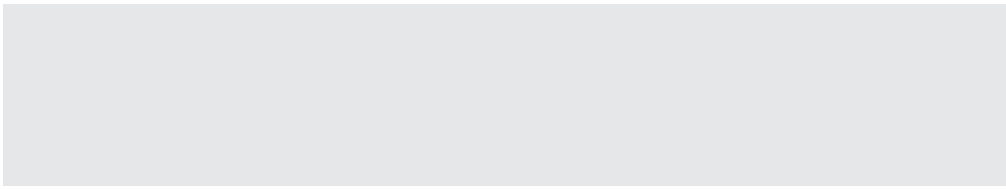

## **INTERIOR STANDARDS**

## 3.1.1 Interior Floor Surfaces

### RATIONALE

The selection of flooring materials can be critical to the safe and easy movement of persons using all kinds of mobility aids, as well as persons with low vision.

Floor finishes, such as carpet, should be selected and installed so that persons using wheelchairs and walkers or other mobility aids can easily travel over them without using undue energy or tripping. Finishes that are slip resistant and not highly reflective also promote safe travel.

Glare from polished floor surfaces can be a safety issue and uncomfortable for all users and can be a particular obstacle for individuals with vision *impairments*.

Pronounced *colour contrast* between walls and floor finishes may be helpful for individuals with vision *impairments*, as are changes in colour/texture where a change in level or function occurs.

Caution is recommended in the selection of heavy or distinct patterns on walls or floors since these can add visual confusion to settings for persons with low vision or for persons with perceptual or cognitive impairments, if overused. Simple, repetitive and non-directional patterns with low contrast are preferred (e.g., for carpeting, floor tiles, wall papers, etc.) in order to produce the least amount of visual confusion.

Thick pile carpeting makes pushing a wheelchair very difficult. Small and uneven changes in floor level represent a further *barrier* to using a wheelchair but also present a tripping hazard to ambulatory persons.

### APPLICATION

Floor surfaces within all *accessible routes* generally used by staff and public shall comply with this section.

### DESIGN REQUIREMENTS

Floor surfaces shall be stable, firm, slip resistant and glare-free.

Floor surfaces shall not be heavily patterned.

Carpet shall be low profile or low loop construction, directly glued to the subfloor.

Carpet shall not be used on ramps.

Where hard, monolithic materials are selected, they shall be non-slip and non-glare, complying with Section 1.2.1 Textures, Finishes and Colour.

Where floor tiles are used, joints should be no wider than 6 mm (1/4 in.) and should be flush.

Changes in level, except for elevators and other elevating devices, shall conform to Table 3.1.1.1.

Carpets or carpet tile shall:

- be securely fixed;
- have a firm cushion, pad or backing, where used;
- have a level loop, textured loop, level cut pile, or level cut/uncut pile texture with a maximum pad and pile height of 13 mm (1/2 in.); and
- have exposed edges fastened to floor surfaces with trim conforming to Table 3.1.1.1.

### RELATED SECTIONS

- 1.1.3 Accessible Routes, Paths and Corridors
- 1.1.5 Ramps
- 1.1.6 Stairs
- 1.2.6 Detectable Warning Surfaces
- 1.2.1 Texture, Finishes and Colour

3.1.1 Interior Floor Surfaces (continued)

Vertical Rise	Edge Treatment
0 to 5 mm (0 - 1/4")	May be vertical
6 mm and over (1/4")	Treat as a sloped floor or ramp

Table 3.1.1.1 Changes in Floor Level

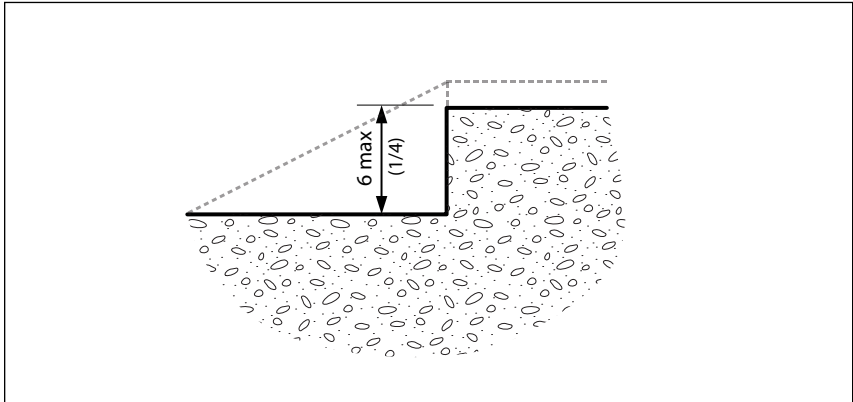

Figure 3.1.1.2 Changes in Level (> 1/4 must be ramped or bevelled)

## 3.1.2 Entrances

### RATIONALE

Design decisions concerning *entrances* will have an immediate impact on the independence and dignity of everyone entering a *facility*. *Entrances* that address the full range of individuals using the *facility* promote a spirit of inclusion that separate accessible *entrances* do not.

Features such as canopies are recommended to minimize the impact of weather conditions and also make an *entrance* more obvious to someone with a cognitive *impairment* or someone unfamiliar with the *facility*.

### APPLICATION

All *entrances* used by staff or the public shall be *accessible* and comply with this section. In *retrofit* situations where it is *technically not feasible* to make all staff and public *entrances* accessible, at least 50% of all staff *entrances* and 50% of all public *entrances* shall be accessible and comply with this section.

In *retrofit* situations where it is *technically not feasible* to make all staff and public *entrances* accessible, the primary *entrances* used by staff and the public shall be *accessible* and comply with this section.

### DESIGN REQUIREMENTS

*Accessible* public *entrances* must be provided in a number at least equivalent to the minimum

number of exits required by the *MBC*.

An *accessible* public *entrance* must be provided to each tenancy in a *facility*.

In police stations public *entrances* that are secured shall be *accessible* as required in Section 3.6.5 Emergency Services.

If direct access is provided for pedestrians from an enclosed parking garage to the *facility*, at least one direct *entrance* from the parking garage to the *facility* must be *accessible*.

If access is provided for pedestrians from a pedestrian tunnel or elevated walkway, one *entrance* to the *facility* from each tunnel or walkway must be *accessible*.

If the only *entrance* to a *facility* or tenancy is a *service entrance*, that *entrance* shall be *accessible*.

*Entrances* which are not *accessible* shall have directional *signage* complying with Section 1.2.4 Signage which indicates the nearest *accessible entrance*.

*Accessible entrances* shall be identified with *signage* complying with applicable provisions of Section 1.2.4 Signage.

### RELATED SECTIONS

- 1.1.1 Space and Reach Requirements
- 1.1.4 Gates, Turnstiles and Openings
- 1.2.4 Signage
- 1.2.5 Information Systems
- 2.1.3 Streetscape
- 3.1.3 Doors
- 3.1.4 Windows, Glazed Screens and Sidelights
- 3.5.2 Card Access, Safety and Security Systems
- 3.5.3 Interior Lighting

3.1.2 Entrances (continued)

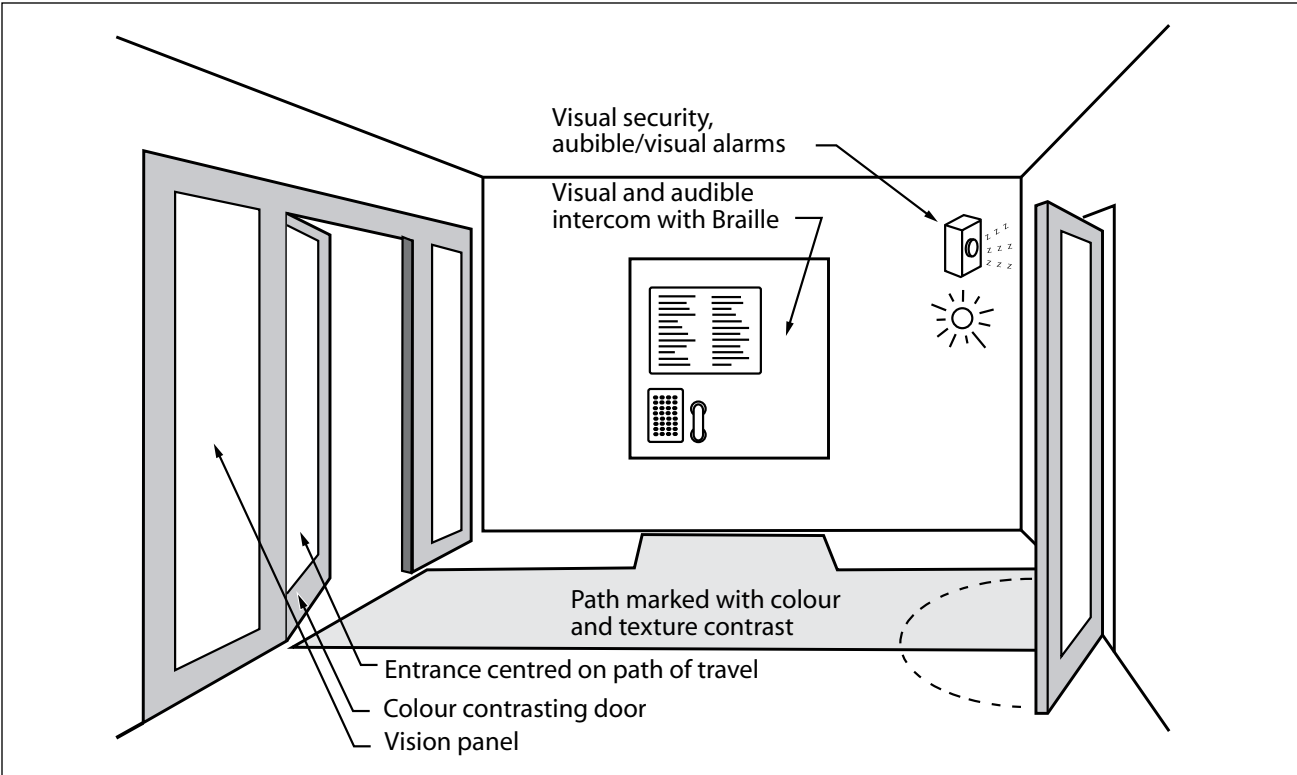

Figure 3.1.2.1 Typical Entrance Foyer

# INTERIOR STANDARDS

## 3.1.3 Doors

### RATIONALE

Sufficiently wide doorways will be advantageous to individuals using wheelchairs, pushing strollers, or making a delivery. A raised threshold at the base of the door could impede any one of these same individuals. This same group, with the addition of children, seniors or even someone carrying packages, would have difficulty opening a heavy door and would benefit from some form of *automatic door opener*. *Entrances* without doors are preferred.

Independent use of doors is desirable. Reliance on assistance from others to open doors is not an *accessible* or dignified solution. Automatic hands-free doors provide the most independence, but must include emergency push release or battery backup to ensure operation during power outages.

Where there is ambiguity of which direction the door swings ensure adequate information is provided regarding direction.

Careful thought to the direction of the door swing can enhance the usability and limit the hazard to other pedestrians. Sliding doors can be easier for some individuals to operate, and can also require less wheelchair maneuvering *space*. Doors that require two hands to operate are not considered to be accessible. Revolving doors are not accessible for persons using wheelchairs and strollers. The coordination required to

use such doors may be difficult for children or someone with a cognitive *impairment*.

Glazed doors can present a hazard to all individuals and especially those with vision *impairments*. The inclusion of *colour contrast* strips across the glass, mounted at eye level, as well as *colour contrasting* door frames and door hardware, will increase the safety and visibility of a glazed door for a person with a vision *impairment*. Etching on glass may not provide adequate contrast. Frameless glass doors are not recommended.

### APPLICATION

All doors used by staff or the public shall comply with this section. In a *retrofit* situation where it is *technically not feasible* to make all doors *accessible*, at least one door at each *accessible space* shall comply with this section. Exception: Doors not requiring full user passage, such as shallow closets, may have the *clear* opening reduced to 510 mm (20 in.) minimum.

Each door that is an *element* of an *accessible route* shall comply with this section.

Each door required by Section 3.1.8 Emergency Exits, Fire Evacuation and Areas of Rescue Assistance shall comply with this section.

Where a door system incorporates multiple door leaves at a

single location, at least one of the door leaves shall comply with this section.

Power operators shall be provided at the following door locations:

- *entrances* required by Section 3.1.2 Entrances;
- at least one of each gender of washrooms that includes an *accessible* toilet stall, unless the facility is doorless,
- *accessible* individual washrooms;
- *accessible* change rooms;
- intermediate doorways across primary circulation routes within a *facility*. Exception: Doors that are held-open using electromagnetic hold-open devices; and
- *entrances* into primary functional areas within a *facility*, as designated by the *City of Winnipeg*. Exception: Doors that are held-open using electromagnetic hold-open devices.

Mats and mat sinkages at doors shall comply with this section.

Revolving doors or turnstiles shall not be the only means of passage at an *accessible entrance* or along an *accessible route*. An *accessible* gate or door shall be provided adjacent to the turnstile or revolving door and shall be designated to facilitate the same use pattern.

**3.1.3 Doors (continued)**

**DESIGN REQUIREMENTS**

Door hardware on all doors throughout a *facility* (not only those deemed *accessible*), shall comply with the door hardware requirements of this section.

*Accessible* doors shall be on an *accessible route* that complies with Section 1.1.3 Accessible Routes, Paths and Corridors.

The minimum *clear* opening at doorways in *accessible* door systems shall be 915 mm (36 in.). In *retrofit* situations where it is *technically not feasible* to provide this clearance, the minimum *clear*

opening at doorways shall be required to meet *MBC* minimums.

Note: In order to achieve 915 mm (36") minimum clear opening width, the actual door must be 1000 mm (39") minimum.

All doors shall have level wheelchair maneuvering *space* on both sides of the door, and *clear space* beside the latch, as described in Table 3.1.3.1.

Exception: The *clear space* is not required on the inactive side of a door, where access is provided from one side only - such as to a closet.

The required *clear space* beside the latch is to be unobstructed for the full height of the door.

The minimum *space* between two hinged or pivoted doors in series shall be 1525 mm (60 in.), plus the width of any door swinging into the *space*.

Thresholds shall be not more than 13 mm (1/2 in.) high. 6 mm (1/4 inch) is preferred.

Door hardware (operating devices such as handles, pulls, latches, and locks) shall:

Context	Floor Space Required (in mm)		
	Depth	Width	Space beside latch
<b>Side-hinged door - Front approach (Figure 3.1.3.3)</b>			
Pull side	1525 (60 in.)	1600 (63 in.) (*1525 (60 in.))	600 (23-5/8 in.)
Push side	1370 (54 in.)	1250 (49-1/4 in.) (*1220 (48 in.))	300 (11-3/4 in.)
<b>Side-hinged door - Latch-side approach (Figure 3.1.3.1)</b>			
Pull side	1370 (54 in.) (*1220 (48 in.))	1600 (63 in.) (*1525 (60 in.))	600 (23-5/8 in.)
Push side	1370 (54 in.) (*1100 (43-1/4 in.))	1525 (60 in.)	600 (23-5/8 in.)
<b>Side-hinged door - Hinge-side approach (Figure 3.1.3.2)</b>			
Pull side	2440 (96 in.) (*1525 (60 in.))	2440 (96 in.) (*1525 (60 in.))	600 (23-5/8 in.)
Push side	1370 (54 in.) (*1100 (43-1/4 in.))	1830 (72 in.)	450 (17-3/4 in.)
<b>Sliding door (Figure 3.1.3.8)</b>			
Front approach	1370 (54 in.)	1100 (43-1/4 in.) (*920 (36 in.))	50 (2 in.)
Side approach	1370 (54 in.) (*1100 (43-1/4 in.))	1550 (61 in.) (*1370 (54 in.))	540 (21-1/2 in.)

**Table 3.1.3.1** Maneuvering *Space* at Doors

In *retrofit* situations where it is *technically not feasible* to provide the required clearances at doors, the clearances may be reduced as shown by the asterix (\*).

# INTERIOR STANDARDS

## 3.1.3 Doors (continued)

- not require fine finger control, tight grasping, pinching, or twisting of the wrist to operate; and
- be mounted no higher than 1100 mm (43 1/4) from the finished floor.

Operating hardware on sliding doors shall be exposed and usable from both sides when sliding doors are fully open.

The maximum door opening force for pushing or pulling open a door shall be:

- 38 N (8.5 lb.) for exterior hinged doors;
- 22 N (4.6 lb.) for interior hinged doors; and
- 22 N (4.6 lb.) for sliding or folding doors.

Door closers shall be adjusted to the least pressure possible,

but never more than the opening forces noted above.

The sweep period of door closers shall be adjusted so that, from an open position of 90 degrees, the door will take not less than 3 seconds to move to a semi-closed position of approximately 12 degrees.

*Power-assisted* swinging doors shall:

- take not less than 3 seconds to move from the closed to the fully open position;
- be equipped with an object sensor that stops the door from closing on a person or object while in the swing opening; and
- require a force of not more than 66 N (13.8 lb.) to stop door movement.

Permanent mats and metal gratings at *entrances* and in vestibules shall be recessed flush with the floor, so as not to create a tripping hazard.

Occasional mats (e.g. runners used in bad weather) should be level with the floor surface and/or have a gently beveled edge, so as not to create a tripping hazard.

Where power door operators are provided, operator controls shall:

- be a single control bar that can be activated from either height (preferred) or;
- be operable at two heights, one with its centre located 850 - 900 mm (33-1/2 - 35 1/5 in.) from the floor; and the other with its centre located 225 mm (9 in.) from the floor.
- be mounted on the latch side of the door or on a stand-

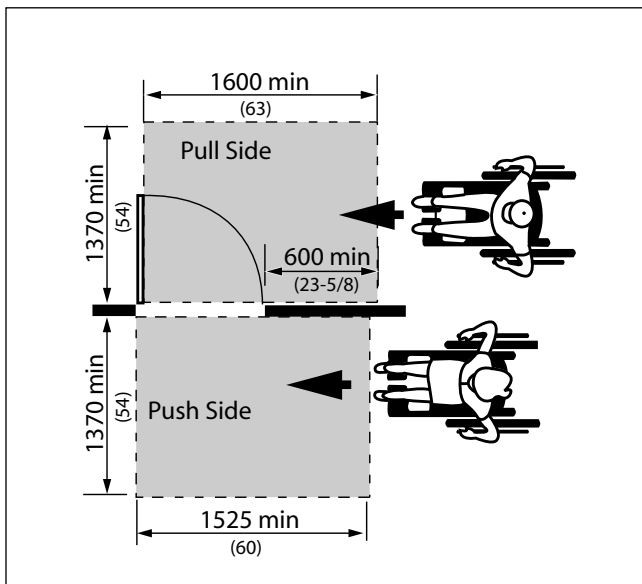

**Figure 3.1.3.1** Latch Side Approach at Hinged Doors (at top of ramps landing must be 2440 mm X 2440 mm min.)

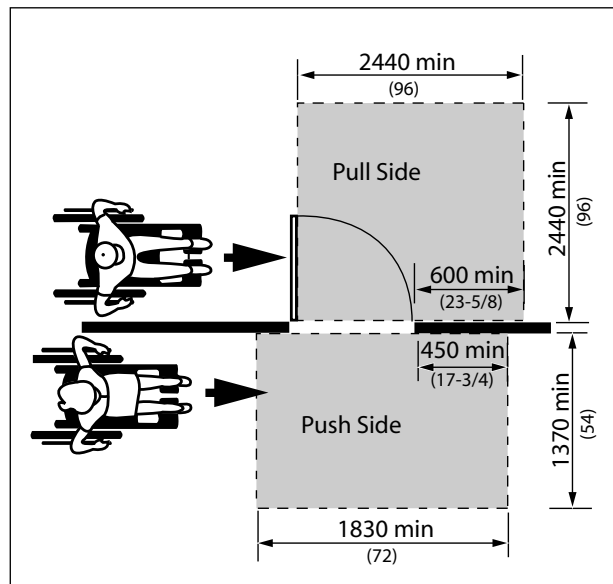

**Figure 3.1.3.2** Hinge Side Approach at Hinged Doors (at top of ramps landing must be 2440 mm X 2440 mm min.)



3.1.3 Doors (continued)

- alone pedestal;
- be located to allow a person using a wheelchair or scooter to stop immediately adjacent to the control;
- be located no closer than 700 mm (27-1/2 in.) from an inside corner, for side-access;
- be located no closer than 400 mm (15-3/4 in.) from an inside corner, for front-access;
- if it is technically not feasible to mount on the latch side of the door, and if located on hinge side of door it controls, be located not less than 600 mm (23-5/8 in.) beyond the

- door swing, where the door opens towards the control;
- incorporate controls that are clearly visible which are at least 150 mm (5-7/8 in.) in diameter;
- incorporate the International Symbol of Access for Persons with *Disabilities*;
- incorporate systems that will detect individuals using wheelchairs where pressure-sensitive mats, overhead beams or proximity scanners are used to detect traffic;
- incorporate systems that will detect an individual and maintain the door in the open

- position until that person clears the doorway.
- incorporate safety *guards* that comply with Section 1.1.2 Protruding and Overhead Objects, projecting a minimum of 300 mm (11-3/4 in.) beyond both sides of the open door, where exterior doors swing open into a pedestrian area. See Figure 3.1.3.5 and 3.1.3.10.;
- provided a guard *colour contrasted* with the surrounding environment; the guard shall have a tactile floor finish length on all sides of the guard 300 mm (11 3/4 in.) along the floor surface.

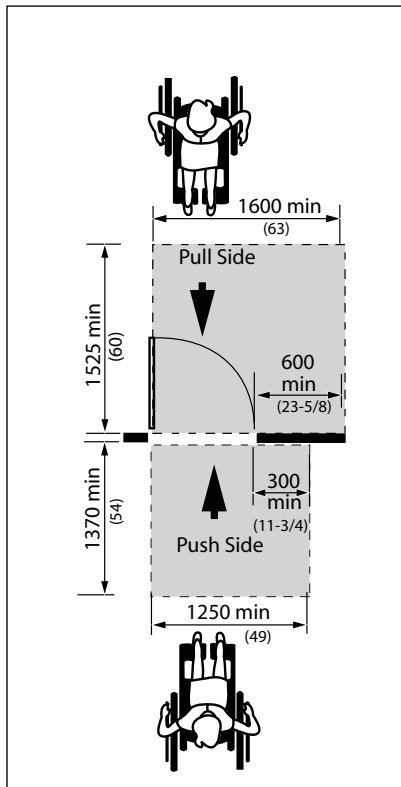

**Figure 3.1.3.3** Front Approach at Hinged Doors  
(at top of ramps landing must be 2440 mm X 2440 mm min.)

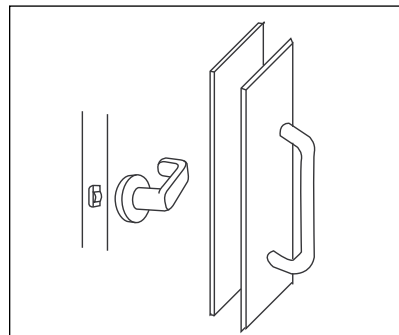

**Figure 3.1.3.3** Examples of Accessible Hardware

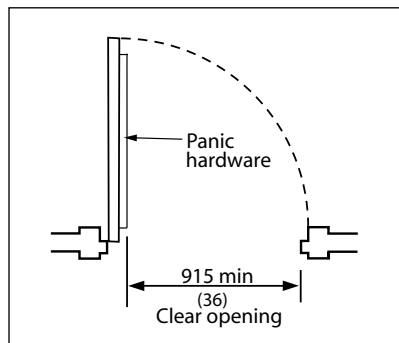

**Figure 3.1.3.5** Minimum Clear Opening at Doors

Where doors are not equipped with a closing device, the edge of door shall be *colour contrasted* to the face of the door. See Figure 3.1.3.6.

On *accessible routes*, the bottom of doors shall incorporate a smooth, uninterrupted kick plate, at least 300 mm (11-3/4 in.) high.

Doors shall incorporate pronounced *colour contrast*, to differentiate them from the surrounding environment. Door handles and other operating mechanisms shall incorporate pronounced *colour contrast*, to differentiate them from the door itself.

Where a door incorporates glazing or is fully glazed, it shall comply with Section 3.1.4 Windows, Glazed Screens and Skylights.

Frameless glass doors shall comply with Section 3.1.4 Win-

3.1 INTERIOR ACCESS AND CIRCULATION

## 3.1.3 Doors (continued)

dows, Glazed Screens and Sidelights.

### RELATED SECTIONS

- 1.1.1 Space and Reach Requirements
- 1.1.4 Gates, Turnstiles and Openings
- 1.2.4 Signage
- 1.2.5 Information Systems
- 3.1.4 Windows, Glazed Screens and Sidelights
- 3.5.1 Controls and Operating Mechanisms
- 3.5.2 Card Access, Safety and Security Systems

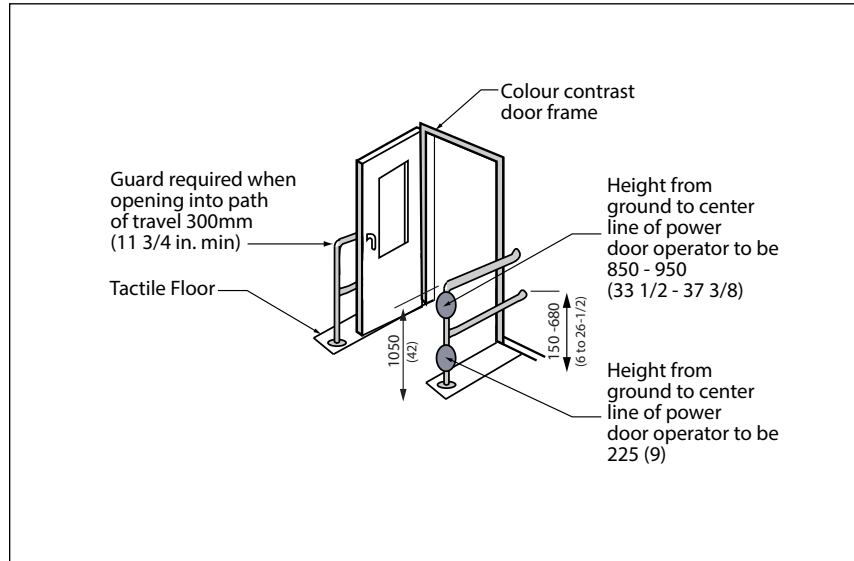

**Figure 3.1.3.6** Colour Contrast at Doors and Protective Safety Guards

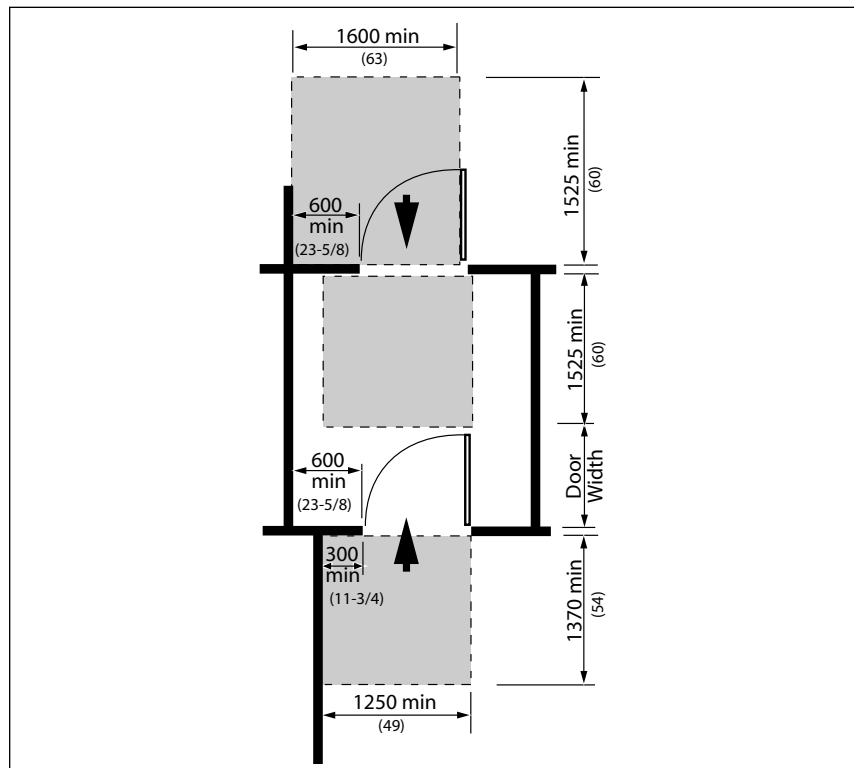

**Figure 3.1.3.7** Maneuvering Space at Doors in Series (at top of ramps landing must be 2440 mm X 2440 mm min.)

3.1.3 Doors (continued)

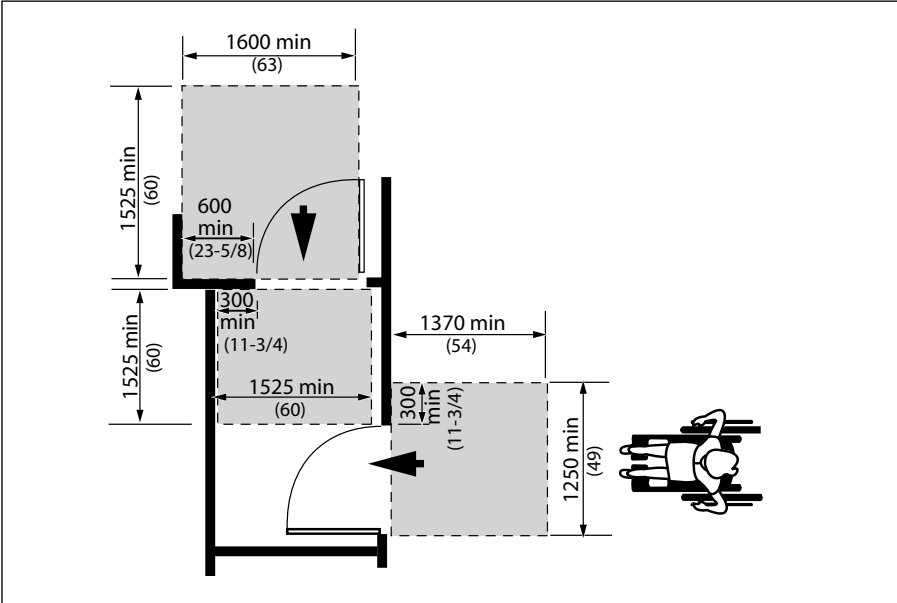

Figure 3.1.3.8 Maneuvering Space at Doors in Series (at top of ramps landing must be 2440 mm X 2440 mm min.)

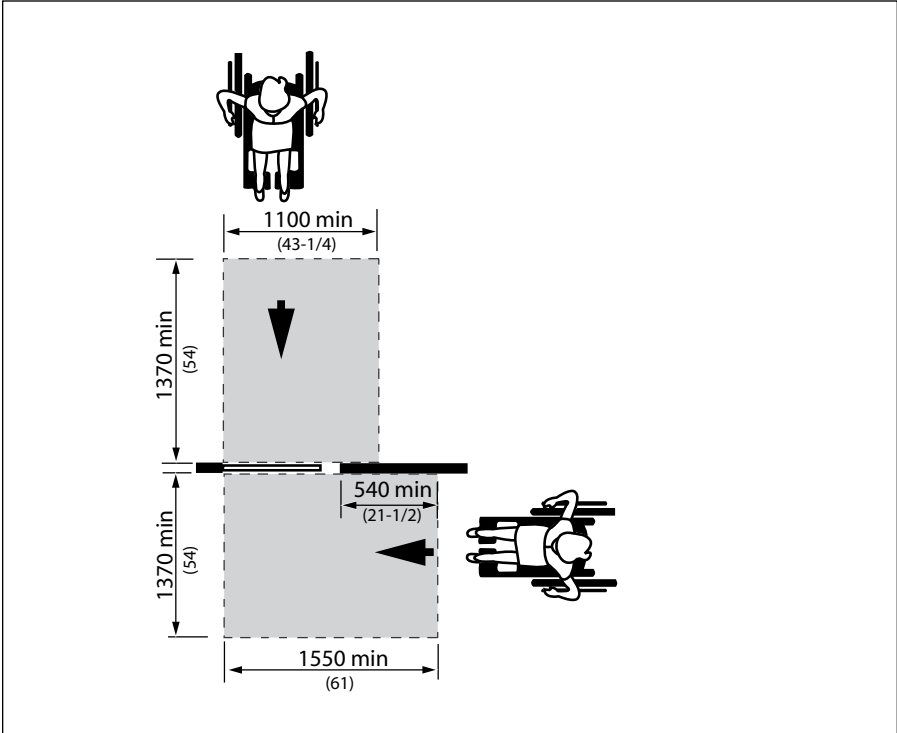

Figure 3.1.3.9 Front and Side Approach at Sliding Doors (at top of ramps landing must be 2440 mm X 2440 mm min.)

3.1 INTERIOR ACCESS AND CIRCULATION

3.1.3 Doors (continued)

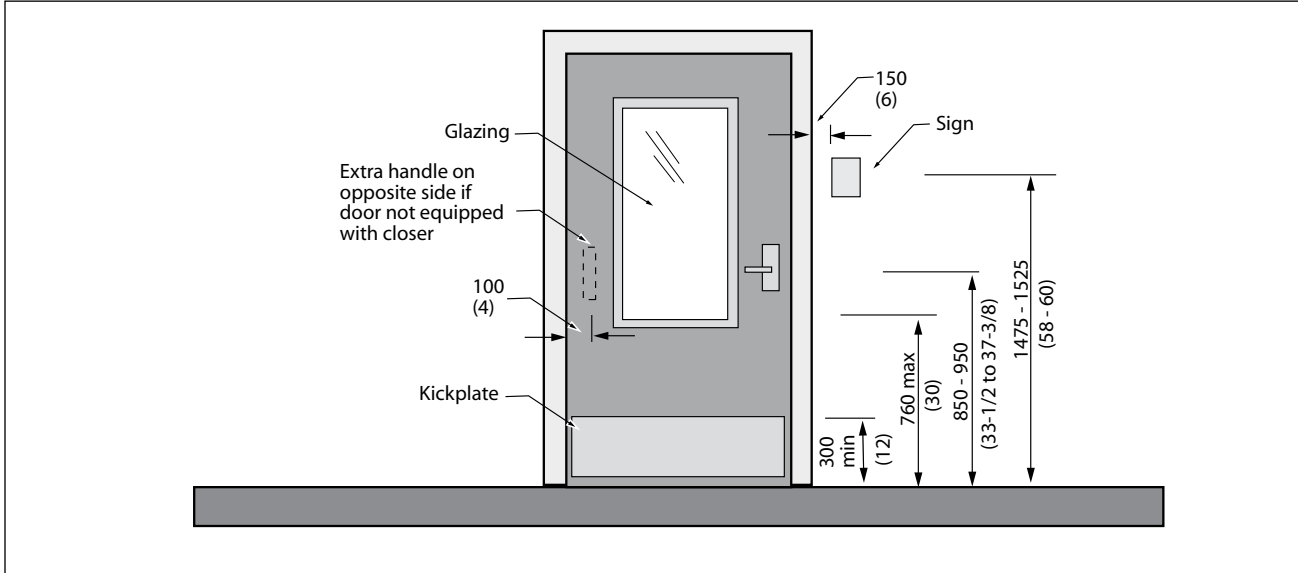

Figure 3.1.3.10 Door Features

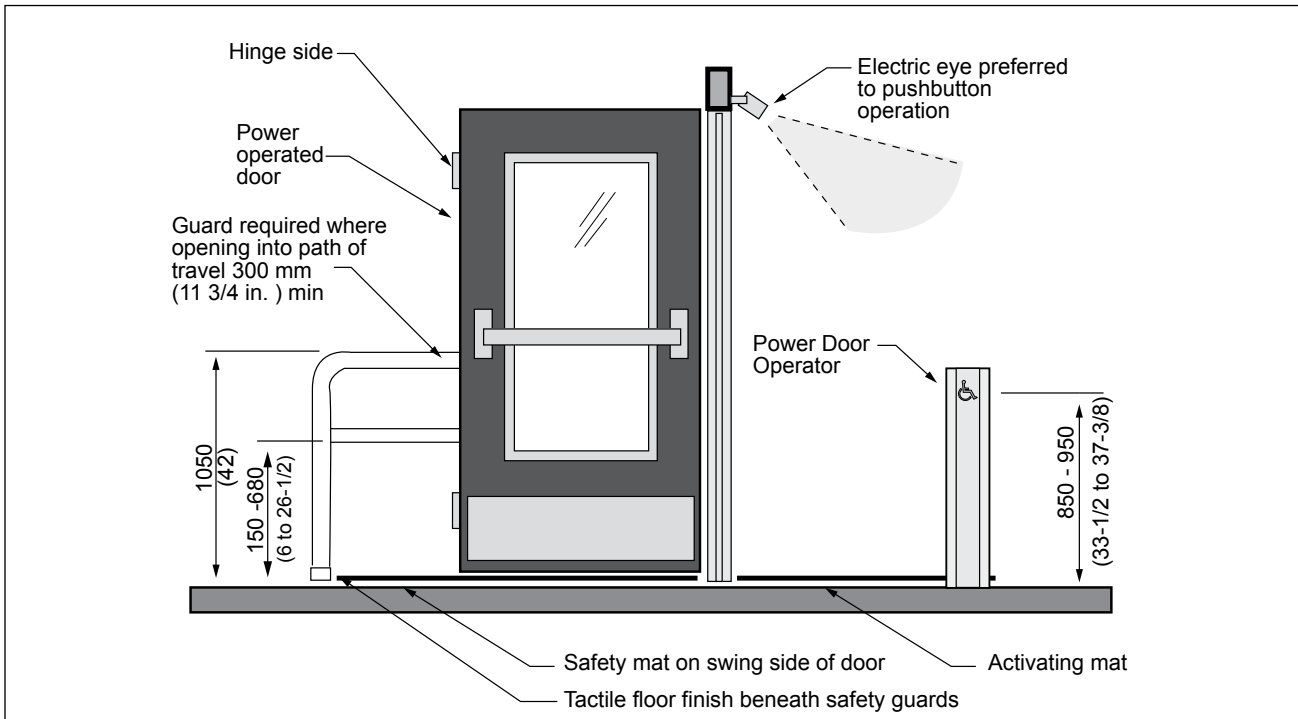

Figure 3.1.3.11 Power Door Features, Also Refer to Figure 3.1.3.7

**3.1.4 Windows, Glazed Screens and Sidelights**

**RATIONALE**

Broad expanses of glazing in screens, sidelights and doors can be difficult to detect. This may be a particular concern for individuals with vision *impairments*.

Persons who use wheelchairs or scooters experience the *facility* from a seated position thereby lowering their eye level and reach range. This necessitates the need for lower sill heights and easily reached operating mechanisms. Window controls and operating devices should also respect the limitations of hand strength or dexterity encountered with different types of *disabilities*, including arthritis.

**APPLICATION**

Where windows, glazed screens, fully-glazed sidelights, fully glazed doors, and glazed panels in doors are designed for viewing, they shall comply with this section.

**DESIGN REQUIREMENTS**

Fully-glazed sidelights at exterior *entrances* or vestibules, as well as fully-glazed screens, shall be clearly identified with a horizontal row of decals, or a continuous stripe, minimum 50 mm (2 in.) wide and of contrasting colour, mounted with its centre line between 1475 mm (58 in.) and 1525 mm (60 in.) from the finished floor or ground. Additionally, a second row of decals, or a continuous stripe, a minimum 50 mm (2 in) wide and of highly con-

trasting colour shall be provided, with its center line between 1170 mm (46 in.) and 1220 mm (48 in.) from the finished floor or ground.

Where decals are used, they shall be located at a maximum of 150 mm (5-7/8 in.) from centre to centre. The decals can either be 50 mm (2 in.) square or round, and/or of a special design (e.g., a logo) provided the solid portion of the decals provides high *colour contrast* and is easy to identify by individuals with vision *impairments*.

Where etched or patterned glass is used, decals or a stripe of *contrasting colour* shall still be provided.

Where frameless glass panels are used, exposed edges shall be identified with a vertical safety stripe applied to cap the end glass panel.

Where viewing windows or vision panels are provided:

- the sill height shall be no more than 760 mm (30 in.) from the floor; and
- where horizontal transoms are incorporated in windows, the transoms shall not be located between 1060-1220 mm (47-48") from finished floor.

There may be additional guard requirements under the *MBC*.

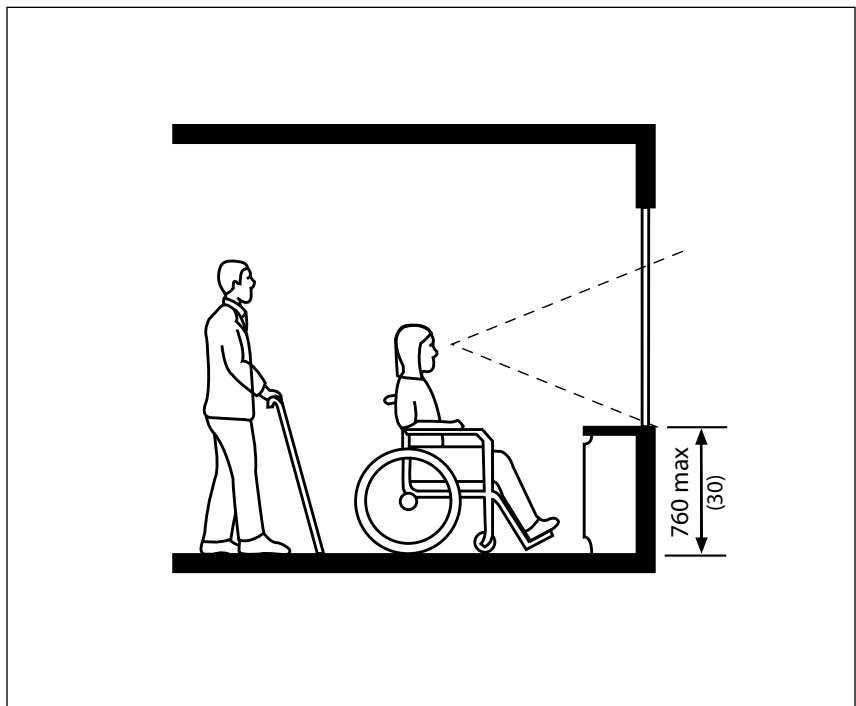

**Figure 3.1.4.1** Window Sill Height

### 3.1.4 Windows, Glazed Screens and Sidelights (continued)

In *facilities* with operable windows, window opening hardware shall:

- be mounted between 400 mm (15-3/4 in.) and 1200 mm (47 in.) from the floor;
- be operable using one hand; and
- not require fine finger control, tight grasping, pinching, or twisting of the wrist to operate.

#### RELATED SECTIONS

- 1.1.1 Space and Reach Requirements
- 3.5.1 Controls and Operating Mechanisms

## 3.1.5 Elevators

### RATIONALE

The buttons used on elevators need to address a range of functional issues as discussed in Sections 1.2.1 Texture, Finishes and Colour and 3.5.1 Controls and Operating Mechanisms. More specific to elevators is the need to provide audible cues for individuals with vision *impairments* to identify different floor levels and the direction of travel. These are of benefit to anyone who uses the elevator. Adequate door-closing delays provide individuals using mobility devices additional time to reach, enter or exit the elevator car.

### APPLICATION

One passenger elevator complying with this section shall serve each level, including *mezzanines*, in all multi-storey facilities, unless exempted below. If more than one elevator is provided, each passenger elevator shall comply with this section.

Freight elevators shall not be required to meet the requirements of this section, unless the only elevators provided are used as combination passenger and freight elevators for use by the public and employees.

Elevator access is not required:

- in elevator pits, elevator penthouses, mechanical rooms, piping or equipment catwalks;
- when *accessible ramps*

complying with Section 1.1.5 Ramps are used in lieu of an elevator; and

- when platform and wheelchair lifts complying with Section 3.1.6 Platform Lifts are used, applicable Provincial Codes are used in lieu of an elevator only under the following exceptional conditions:
  - to provide an *accessible route* to a performing area in an assembly occupancy;
  - to comply with wheelchair viewing position line-of-sight and dispersion requirements of Section 1.3.3 Elevated Areas and Platforms;
  - to provide access to incidental occupied spaces and rooms that are not open to the general public and which house no more than five persons, including, but not limited to, equipment control rooms and projection booths; and
  - to provide access to raised judges' benches, clerks' stations, speakers' platforms, jury boxes and witness stands or to depressed areas, such as the well of a court.

### DESIGN REQUIREMENTS

*Accessible* elevators shall be on an *accessible route* complying with Section 1.1.3 Accessible Routes, Paths and Corridors.

The landing outside the elevator door must be a minimum of 950 mm (37 1/2) wide X 2440 mm (96) in depth

*Accessible* elevators shall be identified with *signage* complying with applicable provisions of Section 1.2.4 Signage.

Elevators shall be automatic and be provided with a two way automatic maintaining levelling device to maintain the floor level to  $\pm 13$  mm (1/2 in.).

*Accessible* elevators shall have power operated horizontal sliding car and landing doors opened and closed by automatic means.

The *clear* width for elevator doors shall be at least 950 mm (37-1/2 in.). In a *retrofit* situation where it is *technically not feasible* to provide a *clear* elevator door width of 950 mm (37-1/2 in.), the *clear* elevator door width may be reduced to 900 mm (35 in.).

Doors shall be provided with a door re-opening device that will function to stop and reopen a car door and an adjacent hoist way door to at least 950 mm (37-1/2 in.), in case the car door is obstructed while closing. This re-opening device shall also be capable of sensing an object or person in the path of a closing door at a nominal  $125 \pm 25$  mm ( $5 \pm 1$  in.) and  $735 \pm 25$  mm ( $29 \pm 1$  in.) above the floor without requiring contact for activation.

Elevator doors should remain fully open for at least 12 sec. or equipped with a sensor that stops

# INTERIOR STANDARDS

## 3.1.5 Elevators (continued)

the door prior to hitting an object or person. This time may be reduced by operation of the door-close button.

The minimum distance between the walls or between wall and door, excluding return panels, shall not be less than 1725 x 1525 mm (68 in. x 60 in.). In facilities with high public use, such as arenas, libraries or entertainment complexes, the distance between walls or between wall and door shall be 2030 x 1525 mm (80 in. x 60 in.).

Car controls shall be consistently placed front facing and readily accessible from a wheelchair upon entering an elevator.

Floor register buttons in elevator cabs shall:

- be a minimum 19 mm (3/4 in.) in size and may be raised, flush or recessed. The depth of flush or recessed buttons when they are being operated shall not exceed 10 mm (3/8 in.); and
- be provided with visual and momentary audible indicators to show when each call is registered. The visual indicators shall be extinguished when each call is answered.

All car control buttons shall be designated by Grade 2 Braille characters and by raised standard alphabet characters for letters, Arabic characters for numbers, and standard symbols. Markings shall be a minimum of

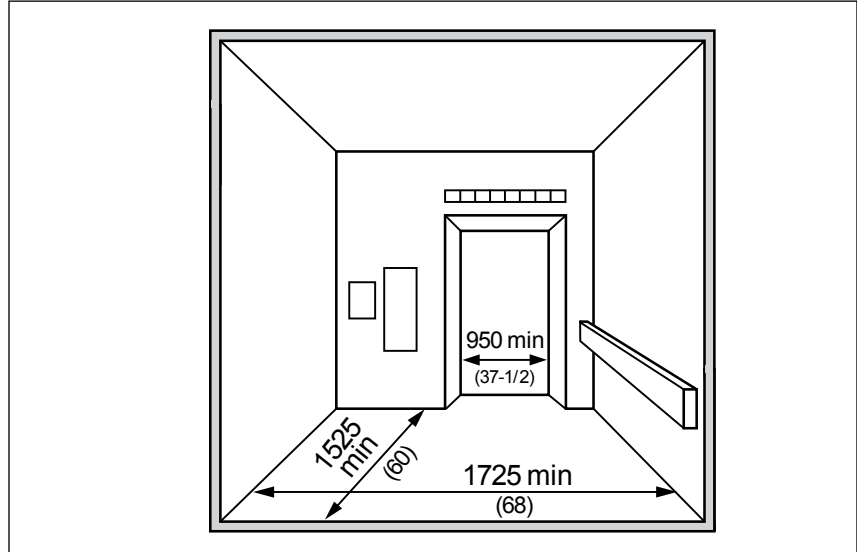

Figure 3.1.5.1 Elevator Cab

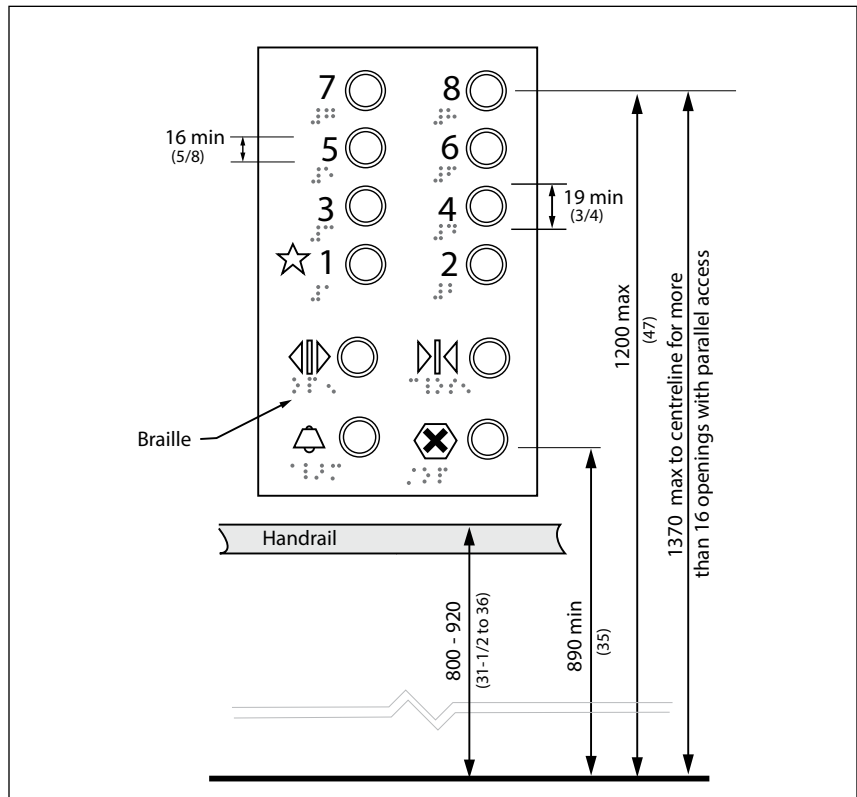

Figure 3.1.5.2 Control Panel



3.1.5 Elevators (continued)

13 mm (1/2 in.) high and raised a minimum of 0.75 mm (1/32 in.), placed immediately to the left of the buttons to which they apply. Exception: Where the call buttons are mechanical, the raised markings may be on the buttons.

Emergency car controls and door-operating buttons shall be grouped together at the bottom of the control panel. The centre line of the alarm button and the emergency stop switch shall be not less than 890 mm (35 in.) from the floor. The centre line of the highest floor button shall be no higher than 1200 mm (47 in.) from the floor. Other controls may be located where it is convenient.

An indicator shall be provided in the car to show the position of the car in the hoist way, by illuminating the indicator corresponding to the landing at which the car is stopped or passing. Indication characters shall be consistently located, mounted on a contrasting colour background and a minimum of 16 mm (5/8 in.) high.

Floors of elevator cabs shall have a firm and slip-resistant surface that permits easy movement of wheelchairs.

*Handrails* shall be provided on all non-access walls at a height of 800 to 920 mm (31-1/2 to 36 in.) with a space of 35 – 45 mm (1 3/8 – 1 3/4 in.) between the rails and wall.

The illumination at the car controls and landing sill shall be not less

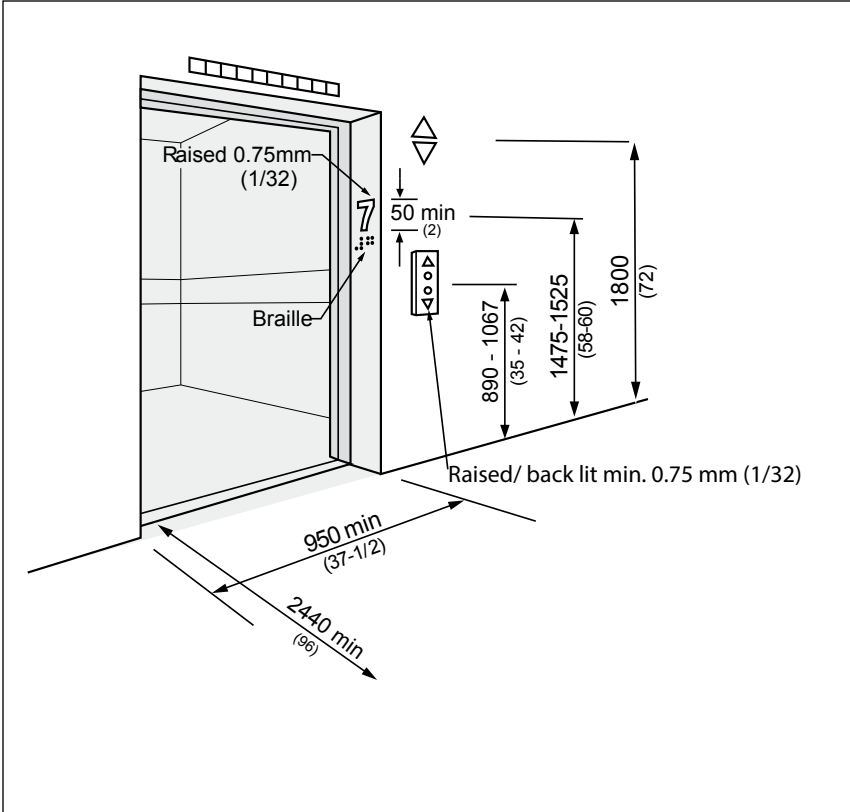

Figure 3.1.5.3 Elevator Entry

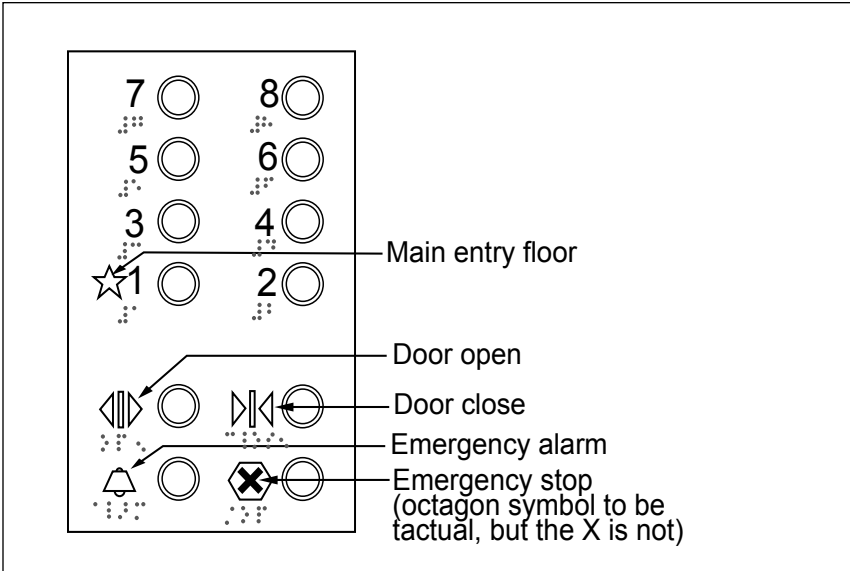

Figure 3.1.5.4 Tactile Symbols

3.1 INTERIOR ACCESS AND CIRCULATION

# INTERIOR STANDARDS

## 3.1.5 Elevators (continued)

than 100 lux (10 ft-candles) and shall be the same lighting level as the adjacent lobby space.

The centre line of hall call buttons shall be 890 - 1067 mm (35 - 42in.) above the floor. Buttons shall be a minimum of 20 mm (13/16 in.) in size, mounted one above the other.

Hall visual indication shall be provided to show each call that is registered and that is extinguished when the call is answered.

Hall or in-car lanterns shall be provided. The centre line of the fixture shall be a minimum of 1830 mm (72 in.) above the floor. An audible signal shall be provided when the elevator stops at the landing. Visual *elements* shall be a minimum of 60 mm (2-3/8 in.) in the smallest direction.

All elevator hoist way *entrances* shall have raised Arabic numerals and Braille floor designations provided on at least one jamb. The characters shall be a minimum of 50 mm high (2 in.) and at least 0.75 mm (1/32 in.) shall be placed on both sides of the door jambs, with the centreline at 1500 ± 25 mm (59 ± 1 in.) from the floor.

As the car stops at a floor, the floor and direction of travel shall be announced using voice-annunciation technology.

Passenger elevators shall be linked by an emergency call system to a monitored location with two way communication ability.

The highest *operable portion* of any two way communication system shall be a maximum of 1200 mm (47 in.) from the floor of the car. It shall be identified by a raised symbol and lettering located adjacent to the device. The symbol shall be a minimum of 38 mm (1-1/2 in.) high and raised a minimum of 0.75 mm (1/32 in.). Permanently attached plates are acceptable. If the system uses a handset, then the length of the cord from the panel to the handset shall be at least 735 mm (29 in.). Additionally, the handset shall be equipped with a receiver that generates a magnetic field in the area of the receiver cap, and the handset shall have a volume control and shall comply with CSA Standard T515. If the system is located in a closed compartment, the compartment door and hardware shall conform to Section 3.5.1 Controls and Operating Mechanisms. The emergency intercommunication system shall not require voice communication. It may be in the form of a panic button.

Mirrors shall not be used below a height of 2000 mm (78-3/4 in.) within elevator cabs as a finish material on the wall *opposite* the door.

Where the dimension of elevator cabs is less than 1500 mm (59 in.) in any direction, an angled mirror shall be provided above a height of 2000 mm (78-3/4 in.) on the wall opposite the door, to assist persons who wheelchairs to back out.

Floor finishes within elevator cabs shall comply with Section 3.1.1 Interior Floor Finishes.

Elevator doors shall incorporate pronounced *colour contrast*, to differentiate them from the surrounding environment.

There shall be a pronounced *colour contrast* between the car sill and the *facility* floor.

### RELATED SECTIONS

- 1.1.1 Space and Reach Requirements
- 1.1.7 Handrails and Guards
- 1.2.1 Texture, Finishes and Colour
- 1.2.4 Signage
- 2.1.1 Exterior Ground Surfaces
- 2.1.2 Exterior Lighting
- 3.1.1 Interior Floor Surfaces
- 3.1.3 Doors
- 3.1.6 Platform Lifts
- 3.5.1 Controls and Operating Mechanisms
- 3.5.2 Card Access, Safety and Security Systems
- 3.5.3 Interior Lighting
- 3.5.4 Interior Glare and Light Sources

### 3.1.6 Platform Lifts

#### RATIONALE

Unless technically not feasible to install an elevator, platform lifts can be necessary in space restricted *retrofit* or heritage applications. Elevators that are used by all *facility* users are preferred to platform lifts which tend to segregate persons with *disabilities* and limit *space* at *entrance* and stair locations. Issues to consider when deciding to use a lift may include the occupancy load of the facility, the frequency of lift use and the limitations the lift may present. Independent access is often compromised, as platform lifts are often controlled by key operation or a push and hold activation switch. Whenever possible, grading or integrated elevator access should be incorporated to avoid the use of lifts.

If there are no suitable alternatives, lifts must be selected to permit the spatial requirement of larger mobility devices such as scooters.

#### APPLICATION

Platform lifts can not be located in exit stairs.

*Accessible* platform lifts shall comply with this section.

Platform lifts may only be used in lieu of an elevator or *ramp* where allowable under 3.1.5.

Exception: Where it is *technically not feasible* to install an elevator or other *accessible* means of change of level in an existing *facility*.

#### DESIGN REQUIREMENTS

*Accessible* platform lifts shall:

- be on an *accessible route* complying with 1.1.3;
- be identified with *signage* complying with applicable provisions of 1.2.4;
- comply with CSA standard CAN/CSA B355 (latest edition); and
- allow for unassisted entry, operation, and exit from the lift.

The platform size shall be no less than 915 x 1525 mm (36 x 60 in.).

The doors to the platform lift shall comply with 3.1.3.

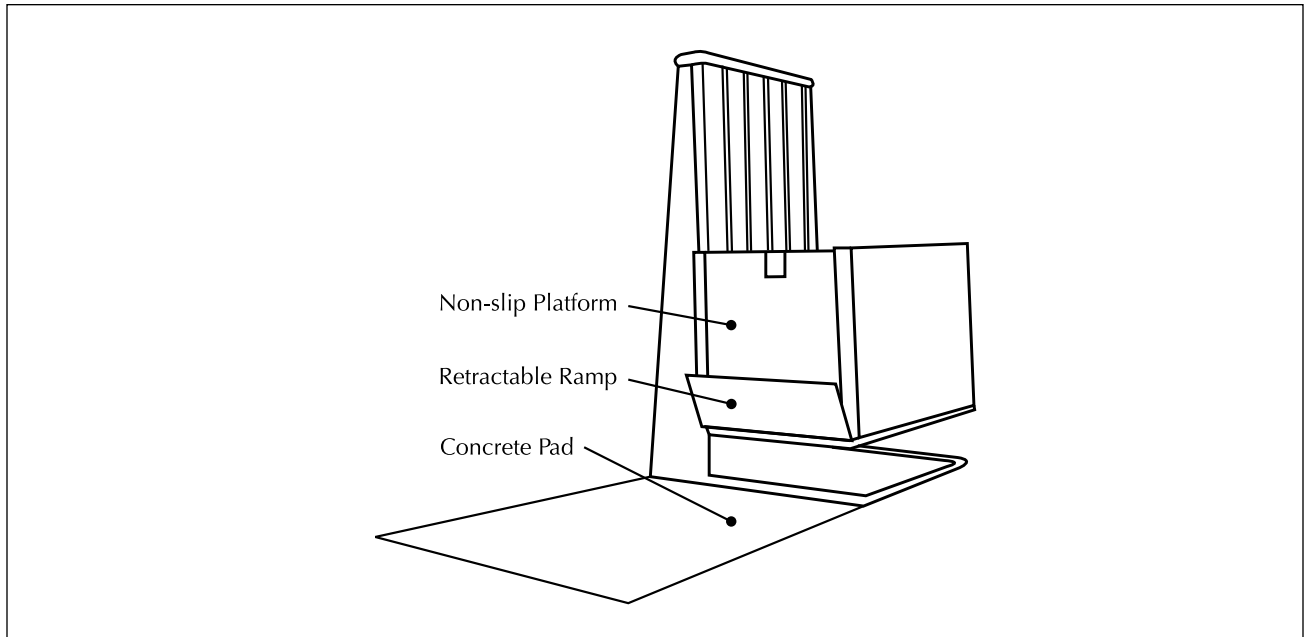

Figure 3.1.6.1 Vertical Platform Lift

## 3.1.6 Platform Lifts (continued)

Controls and operating mechanisms shall comply with 3.5.1.

Platform lifts shall be linked by an emergency call system to a monitored location within the *facility*, with two way communication ability. The highest *operable portion* of the two way communication system shall be a maximum of 1200 mm (47 in.) from the floor of the car. If the system uses a handset, then the length of the cord from the panel to the handset shall be at least 735 mm (29 in.). If the system is located in a closed compartment, the compartment door and hardware shall conform to Section 3.5.1 Controls and Operating Mechanisms.

Floor finishes within platform lifts shall comply with Section 3.1.1 Interior Floor Finishes.

### RELATED SECTIONS

- 1.1.1 Space and Reach Requirements
- 1.1.7 Handrails and Guards
- 1.2.1 Texture, Finishes and Colour
- 1.2.4 Signage
- 2.1.1 Exterior Ground Surfaces
- 3.1.1 Interior Floor Surfaces
- 3.1.3 Doors
- 3.1.5 Elevators
- 3.5.1 Controls and Operating Mechanisms
- 3.5.2 Card Access, Safety and Security Systems
- 3.5.3 Interior Lighting
- 3.5.4 Interior Glare and Light Sources

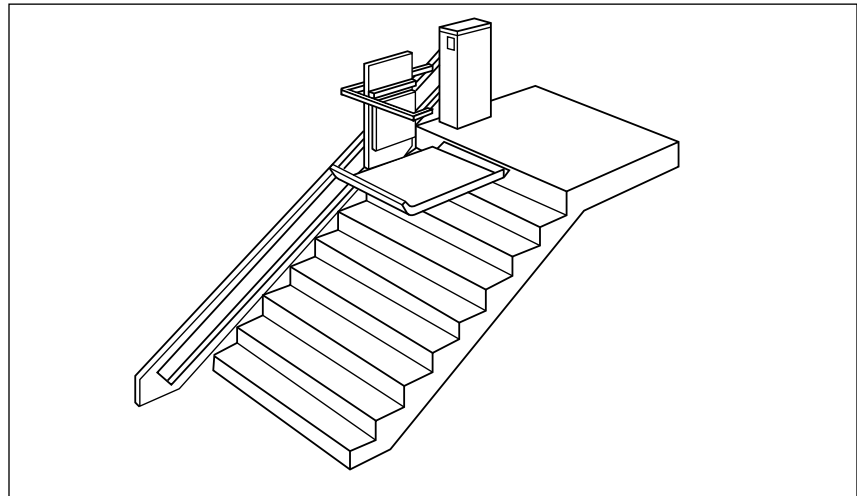

Figure 3.1.6.2 Inclined Platform Stair-Lift

### 3.1.7 Escalators

#### RATIONALE

Boarding and stepping off of an escalator can be challenging for many people. Lack of contrast on the edge of steps makes it difficult to determine the position of the steps or judge their speed. *Detectable warning surfaces* extending in front of the escalator provide warnings for any pedestrian, especially someone with a vision *impairment*. Contrasting colour strips on stair edges are also necessary.

#### APPLICATION

Escalators shall comply with this section.

#### DESIGN REQUIREMENTS

Escalator installations shall include high definition (*colour contrast*) of tread edges and nosing.

*Detectable warning* surfaces that comply with Section 1.2.6 Detectable Warning Surfaces shall be provided at the head and foot of the escalator.

The surface of escalator treads shall be in a matte finish, to minimize reflected glare.

Lighting over escalators shall be a minimum of 200 lux (18.4 ft-candles), evenly distributed, from a low-glare light source.

#### RELATED SECTIONS

- 1.1.1 Space and Reach Requirements
- 1.2.1 Texture, Finishes and Colour
- 1.2.4 Signage
- 1.2.6 Detectable Warning Surfaces
- 3.1.1 Interior Floor Surfaces
- 3.5.4 Interior Glare and Light Sources
- 3.1.2 Interior Lighting

## 3.1.8 Emergency Exits, Fire Evacuation and Areas of Rescue and Assistance

### RATIONALE

In order to be *accessible* to all individuals, emergency exits must include the same accessibility features as other doors. The doors and routes must also be marked in a way that is *accessible* to all individuals, including those who may have difficulty with literacy, such as children or persons speaking a different language. In the event of fire when elevators cannot be used, areas of rescue assistance are an asset to anyone who would have difficulty traversing sets of stairs.

### APPLICATION

The main floors of *facilities* required to be *accessible* shall incorporate *accessible means of egress* in the same number as required by the *MBC*.

Above the main level, where required exits from a floor level are not accessible, the only *means of egress* will be to an *area of rescue assistance*.

*Areas of rescue assistance* shall be provided on the floor level in a number equal to that of the required exits.

Every *occupiable* level in non-residential occupancies above or below the first *storey* (as defined by the *MBC*) that is *accessible*, shall:

- be served by an elevator that has protection features, as specified in Section 3.3.1.7 of the *MBC*; or

- be divided into at least two zones by fire separations, as specified in the *MBC*.

In *occupiable* levels above or below the first *storey* in residential occupancies, the requirements for a protected elevator or two fire zones may be waived, if an appropriate balcony, as specified in Section 3.3.1.7 of the *MBC*, is provided for each suite.

Areas of rescue assistance shall comply with this section.

A horizontal exit meeting the requirements of the *MBC* shall satisfy the requirements for an *area of rescue assistance*.

### DESIGN REQUIREMENTS

Where emergency warning systems are provided, they shall include both audible alarms and visible alarms. Visual alarms shall comply with Section 3.4.1 Visual Alarms.

*Accessible means of egress* shall comply with Section 1.1.3 Accessible Routes, Paths and Corridors.

*Accessible means of egress* shall be identified with *signage* complying with applicable provisions of Section 1.2.4 Signage.

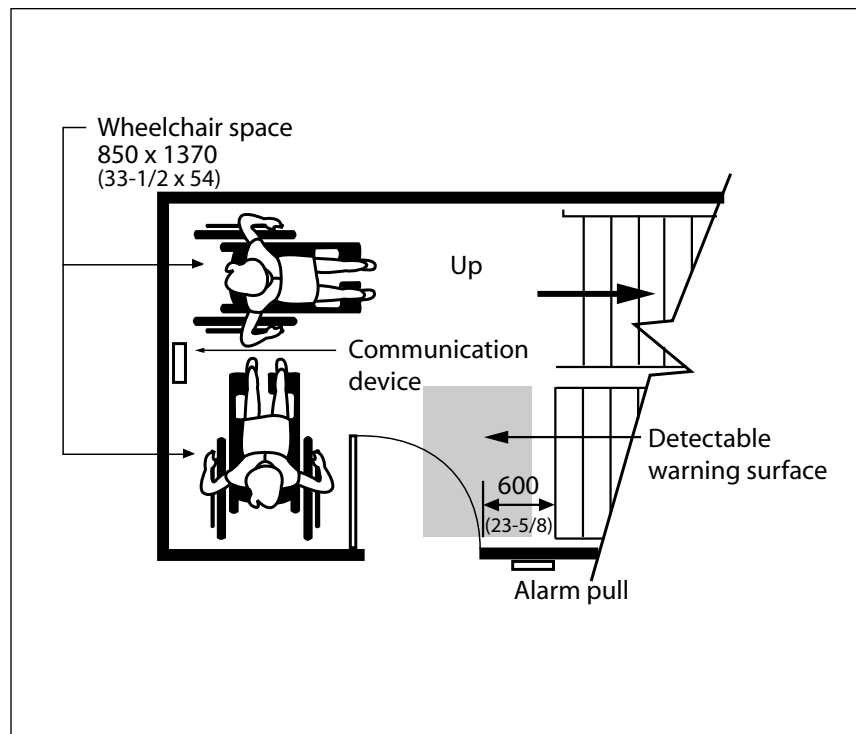

Figure 3.1.7.1 Area of Rescue Assistance

**3.1.8 Emergency Exits, Fire Evacuation and Areas of Rescue and Assistance (continued)**

Areas of rescue assistance shall:

- be located on an *accessible route* complying with Section 1.1.3 Accessible Routes, Paths and Corridors;
- incorporate a two way voice communication system for use between each *area of rescue assistance* and the central alarm and control *facility*;
- be identified with directional *signage* complying with applicable provisions of Section 1.2.4 Signage, stating 'Area of Rescue Assistance' and incorporate the international symbol for accessibility for *disabled* persons;
- have a door in compliance with Section 3.1.3 Doors;
- incorporate the number of rescue spaces in accordance with Table 3.1.7.1;
- be of a size that allows a minimum floor *space* of 850 mm (33-1/2 in.) x 1370 mm (54 in.) per non-ambulatory occupant;
- be separated from the floor area by a fire separation having a fire-resistance rating at least equal to that required for an exit;
- be served by an exit or firefighter elevator;
- be designated as an *area of rescue assistance* for persons with *disabilities* on the *facility* plans and in the *facility*;
- be smoke protected in *facilities* of more than three *storeys*;
- be identified on all publicly

- displayed floor evacuation plans;
- be identified on floor evacuation plans that are available in alternate formats; and
- be designated in evacuation procedure documents.

**RELATED SECTIONS**

All relevant parts of Sections 1.0 General Design Standards, 2.0 Exterior Design Standards and 3.0 Interior Design Standards.

Occupant load of the floor area served by the area of rescue assistance	Minimum number of rescue spaces
2 to 400	2
Over 400	3 plus 1 for each additional increment of 200 persons in excess of 400 persons

**Table 3.1.7.1** Number of Rescue Spaces

## 3.2.1 Information, Reception and Service Counters

### RATIONALE

Information, reception and service counters should be accessible to all visitors. A choice of counter heights is recommended to provide a range of options for a variety of persons. Lowered sections will serve children, persons of short stature and persons using wheelchairs. The choice of heights should also extend to commercial *speaking ports* and writing surfaces. The provision of *knee space* under the counter facilitates use by a person using a wheelchair. The use of *colour contrast*, *tactile* difference or audio landmarks (e.g., receptionist voice or music source) can assist individuals with vision *impairments* to more precisely locate service counters or commercial *speaking ports*.

In secure locations, such as police stations and/or cash counters consideration must be given to safety, employee and/or customer reach ranges and accessibility and a balanced design approach must be taken.

### APPLICATION

Counters for information or service shall have at least one section usable by persons in wheelchairs. The service provider shall be at the same level as those being served.

### DESIGN REQUIREMENTS

Information, reception and service counters shall be located on an

*accessible route* complying with Section 1.1.3 Accessible Routes, Paths and Corridors.

Counters for information or service shall incorporate at least one *accessible* section that is located between 710 mm (28 in.) and 865 mm (34 in.) above the finished floor or ground. This section shall be at least 920 mm (36 in.) wide.

*Accessible* sections of information, reception and service counters shall have, on both sides of the counter, *knee space* below of at least 700 mm (27-1/2 in.) high by 500 mm (19-5/8 in.) deep.

Wheelchair seating *spaces* at *accessible* sections of information, reception and service counters shall incorporate a *clear space* not less than 760 mm (30

in.) by 1370 mm (54 in.).

Where a forward approach is used to access a wheelchair seating *space*, a *clear knee space* of at least 760 mm (30 in.) wide, 500 mm (19 5/8 in.) deep and 700 mm (27 1/2 in.) high shall be provided.

Where commercial *speaking ports* are provided at information, reception or service counters, at least one such position should have a commercial *speaking port* no higher than 1060 mm (42 in.) above the finished floor or ground.

If counter extension is used to accomplish adequate knee clearance, ensure it meets the requirements of Section 1.1.3 Accessible Routes, Paths and Corridors.

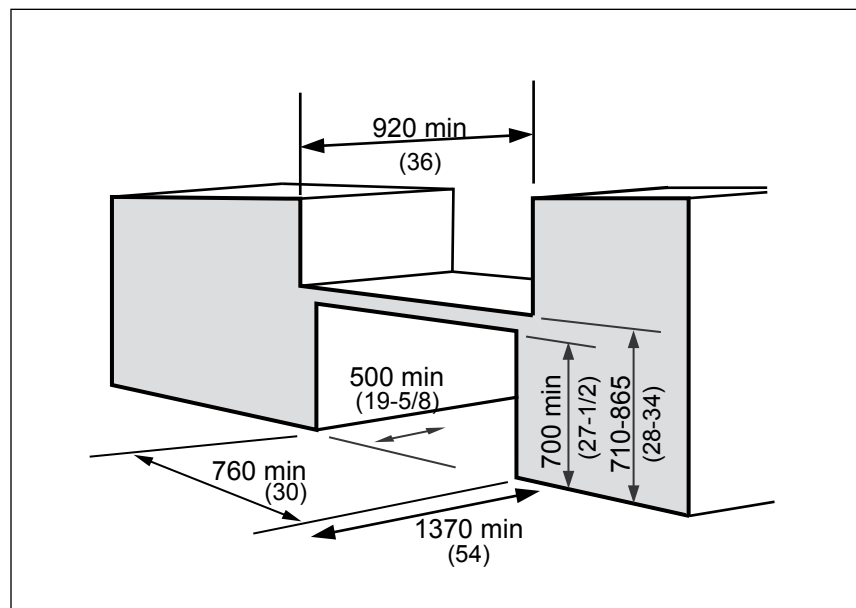

Figure 3.2.1.1 Service Counter



## 3.2.1 Information, Reception and Service Counters (continued)

Point of sale mechanisms must be accessible (portable or reachable) to all users see Figure 3.5.1.2.

### RELATED SECTIONS

- 1.1.1 Space and Reach Requirements
- 1.1.3 Accessible Routes, Paths and Corridors
- 1.2.1 Texture, Finishes and Colour
- 1.2.2 Acoustics
- 1.2.4 Signage
- 1.2.5 Information Systems
- 3.5.1 Controls and Operating Mechanisms
- 3.4.2 Assistive Listening Systems
- 3.5.3 Interior Lighting
- 3.5.4 Interior Glare and Light Sources

## 3.2.2 Tables and Work Surfaces

### RATIONALE

Tables and work surfaces should accommodate the needs of a range of users. Consideration should be given to standing-use as well as seated use. For individuals using wheelchairs, tables need to be high enough to provide knee space with enough clear space to pull into. The furniture placement at tables and maneuvering space at counters should provide sufficient turning space for a person using a wheelchair or scooter.

### APPLICATION

If fixed or built-in tables, and work surfaces (including, but not limited to, dining tables and study

carrels) are provided in accessible public or common use areas, at least 10%, but not less than one, of the fixed or built-in tables, counters and work surfaces shall comply with this section.

### DESIGN REQUIREMENTS

Accessible tables, and work surfaces shall be located on an accessible route complying with Section 1.1.3 Accessible Routes, Paths and Corridors.

An accessible route complying with Section 1.1.3 Accessible Routes, Paths and Corridors shall lead to and around such fixed or built-in tables, counters and work surfaces.

Wheelchair seating spaces at

accessible tables and work surfaces shall incorporate a clear space of not less than 900 mm (35-1/2 in.) by 1500 mm (59 in.).

Where a forward approach is used to access a wheelchair seating space, a clear knee space of at least 760 mm (30 in.) wide, 500 mm (19-5/8 in.) deep and 700 mm (27-1/2 in.) high shall be provided. It may overlap the clear space by a maximum of 500 mm (19-5/8 in.).

The top of accessible tables, and work surfaces shall be located between 710 mm (28 in.) to 865 mm (36 in.) above the finished floor or ground or be height adjustable with operable parts in compliance with Section 3.5.1

Cabinets shall:

- incorporate doors that are colour contrasted; and
- incorporate hardware that is colour contrasted to the doors, and is in compliance with Section 3.5.1 Controls and Operating Mechanisms.

### RELATED SECTIONS

- 1.1.1 Space and Reach Requirements
- 1.1.3 Accessible Routes, Paths and Corridors
- 3.2.1 Information, Reception and Service Counters

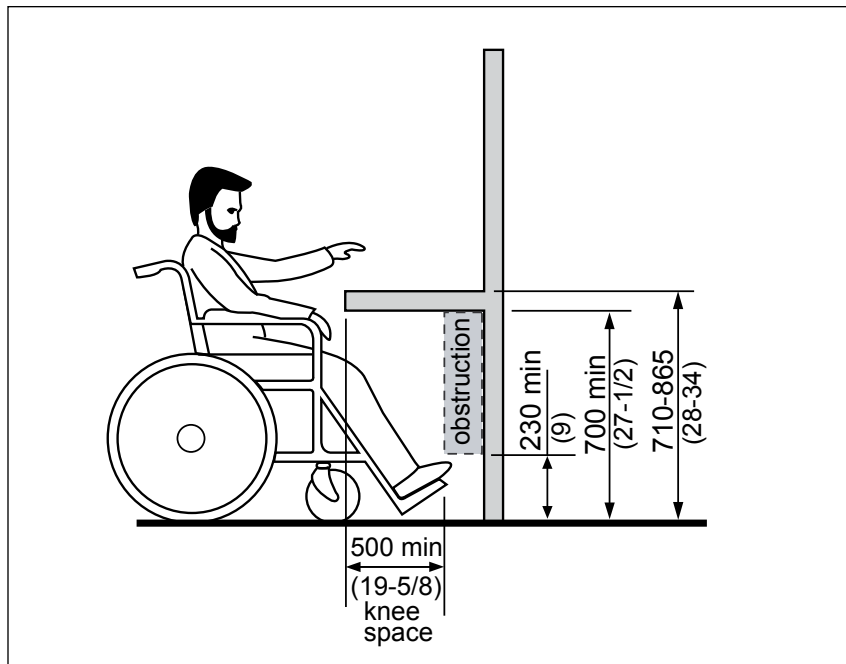

Figure 3.2.2.1 Table, Counter and Work Surface Clearance

3.2.2 Tables and Work Surfaces (continued)

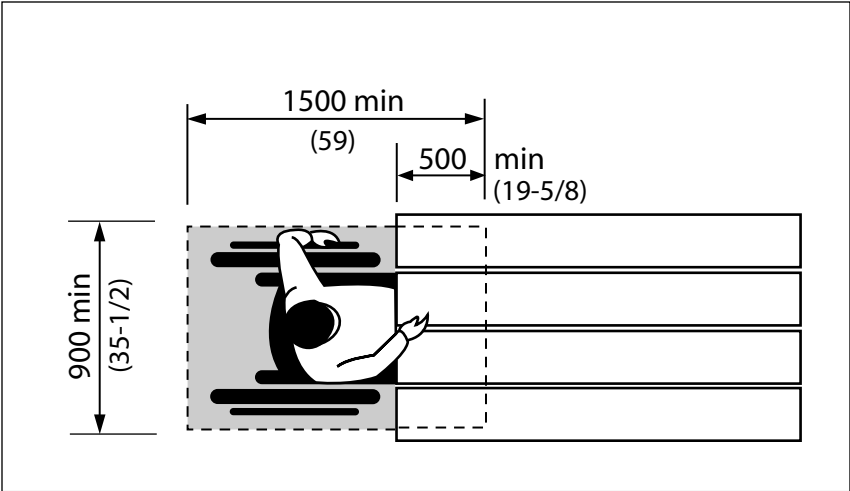

Figure 3.2.2.2 Frontal Approach

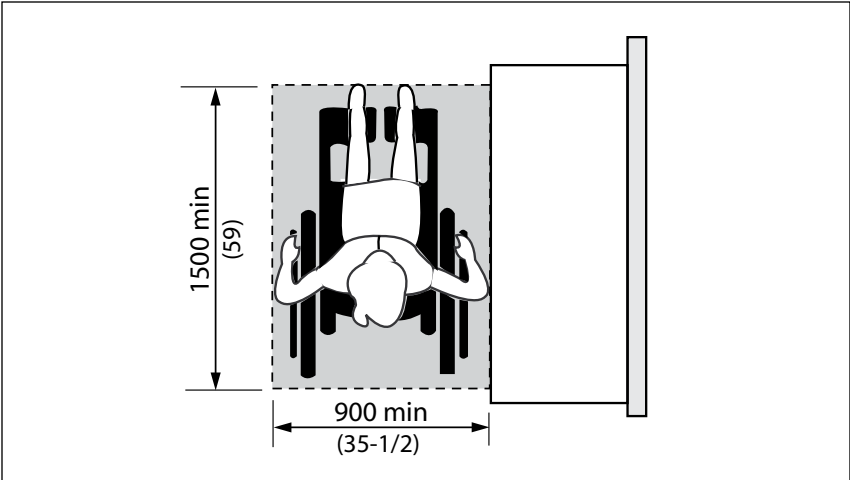

Figure 3.2.2.3 Parallel Approach

3.2 INTERIOR AMENITIES

## 3.2.3 Offices, Work Areas and Meeting Rooms

### RATIONALE

Offices should be *accessible* to all people, both staff and visitors, regardless of mobility. If it is *technically infeasible* to have all offices accessible, at least 25% of the total offices within a floor area shall meet the requirements of this section.

All persons, but particularly those with a hearing *impairment*, would benefit from having a quiet acoustic environment - background noise from mechanical equipment such as fans, should be minimal. Telephone equipment for individuals with hearing *impairments* may also be required.

Tables and workstations should address the knee *space* requirements of an individual in a wheelchair. Circulation areas also need to consider the spatial needs of mobility equipment as large as scooters. See Figure 1.1.1.13, 1.1.1.14 and 1.1.1.15.

Natural coloured task lighting is a design feature that will facilitate use by all, especially persons with vision *impairments*. In locations where reflective glare might be problematic, such as large expanses of glass with reflective flooring, consideration should be given to providing blinds that can be louvered upwards.

### APPLICATION

Wherever offices, work areas or *meeting rooms* are provided for use by the general public, employees, clients or customers,

they shall comply with this section.

### DESIGN REQUIREMENTS

Where offices, work areas and *meeting rooms* are provided for use by the general public, employees, clients or customers, they shall:

- be located on an *accessible route* complying with Section 1.1.3 Accessible Routes, Paths and Corridors;
- where equipped with a door, the door shall comply with Section 3.1.3 Doors;
- incorporate a *clear space* allowing a person in a wheelchair to make a 180 degree turn (See figure 1.1.1.5);
- incorporate an *accessible route* through the *space* that does not require the person in a wheelchair to travel backwards to enter/leave the *space*;
- incorporate an *accessible route* in compliance with 1.1.3 that connects the primary activity *elements* within the office, work area or *meeting room*;
- incorporate knee clearances below work surfaces that comply with Section 3.2.2 Tables, Counters and Work Surfaces;
- incorporate access in compliance with Section 3.2.5 Storage, Shelving and Display Units for storage, shelving or display units for use by the general public,

clients or customers;

- provide a *clear space* in front of the equipment that complies with Section 1.1.1 Space and Reach Requirements, where equipment such as photocopiers are provided for use by the general public, clients or customers; and
- be equipped with an assistive listening system that complies with Section 3.4.2 Assistive Listening Systems, where an assistive listening system is required.

### RELATED SECTIONS

All relevant parts of Sections 1.0 General Design Standards, 2.0 Exterior Design Standards and 3.0 Interior Design Standards.

### 3.2.4 Kitchens and Kitchenettes

#### RATIONALE

Kitchens, kitchenettes and coffee stations require an appropriate level of access to be usable by persons with *disabilities*. Adequate maneuvering space is required for users of mobility equipment to approach and use work surfaces, storage *elements* and appliances. A frontal approach to work surfaces and appliances is generally preferred, except at refrigerators where a side approach is preferred. Where a frontal approach is used, knee space and toe space are required.

The use of *colour contrast* between kitchen *elements* will assist persons with low vision locate surfaces, appliances and controls. Darker coloured work surfaces are preferable as they make it easier to identify objects located on them.

#### APPLICATION

Kitchens and kitchenettes intended for use by staff or the public shall comply with this section.

At least 50% of shelf *space* in storage facilities shall comply with this section.

#### DESIGN REQUIREMENTS

Pass-through kitchens shall have:

- where counters, appliances or cabinets are on two opposing sides, or when counters, appliances or cabinets are

- opposite a parallel wall, clearance between all opposing base cabinets, counter tops, appliances, or walls within a kitchen work area of 1100 mm (43-1/4 in.) minimum; and
- two entries.

U-shaped kitchens enclosed on three continuous sides shall have a minimum clearance of 2440 mm (96 in.) between all opposing base cabinets, counter tops, appliances, or walls within kitchen work areas. In a *retrofit* situation where providing a 2440 mm (96 in.) *space* is *technically not feasible*, this *space* may be reduced to 2130 mm (84 in.).

Storage *elements* shall:

- be located on an accessible route with adjacent *clear*

*space* in compliance with Section 1.1.1 Space and Reach Requirements;

- comply with at least one of the reach ranges specified in Section 1.1.1 Space and Reach Requirements; and
- incorporate *operable portions* in compliance with Section 3.5.1 Control and Operating Mechanisms.

Kitchen sinks shall:

- be located on an accessible route with adjacent *clear space* for a forward approach. Exceptions: A parallel approach is permitted to a kitchen sink where a cook top or conventional range is not provided and to wet bars;
- where a forward approach is provided, incorporate knee space below at least 760 mm

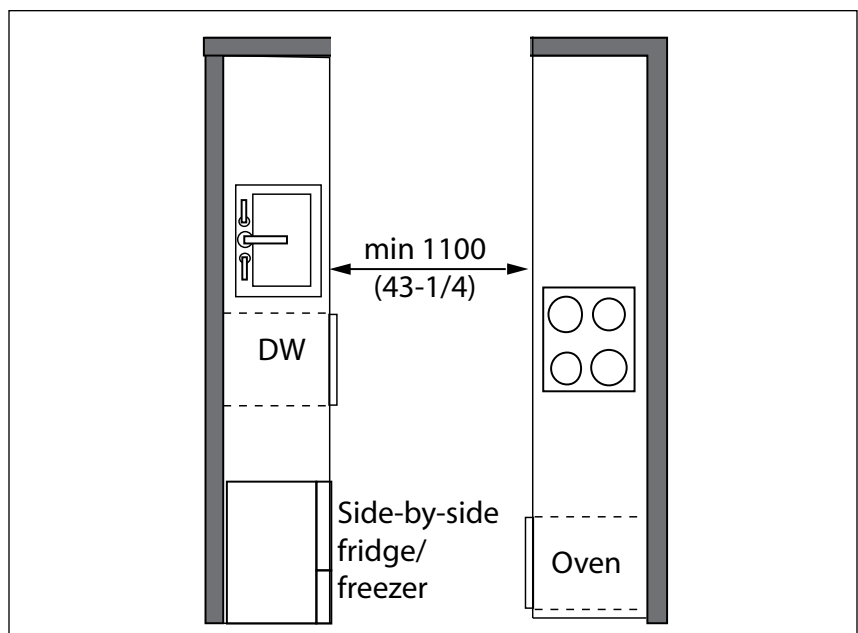

Figure 3.2.4.1 Pass-Through Kitchen

## 3.2 INTERIOR AMENITIES

## 3.2.4 Kitchens and Kitchenettes (continued)

(30 in.) wide, 480 mm (18-7/8 in.) deep, and 685 mm (27 in.) high;

- have the height of the rim or the counter top (whichever is higher) 730 mm – 865 mm (29 in. – 34 in.) max.;
- incorporate faucets and other controls in compliance with Section 3.5.1 Controls and Operating Mechanisms;
- have water supply and drain pipes under the sink insulated or otherwise configured to protect against contact; and
- incorporate no sharp or abrasive surfaces under the sink.

Kitchen appliances shall:

- be located on an accessible route with adjacent *clear space* in compliance with Section 1.1.1 Space and Reach Requirements; and
- incorporate controls and *operable portions* in compliance with Section 3.5.1 Controls and Operating Mechanisms. Exceptions: Appliance doors and door latching devices.

Dishwashers shall incorporate *clear space* adjacent to the dishwasher door. The dishwasher door, in the open position, shall not obstruct the *clear space* for the dishwasher or the sink.

Ranges and cooktops shall:

- incorporate controls that are located to avoid reaching across the burners; and
- where a forward approach is provided:
  - incorporate knee space below at least 760 mm (30 in.) wide, 480 mm (18-7/8 in.) deep, and 700 mm (27-1/2 in.) high; and
  - insulate or otherwise configure the appliance to prevent burns, abrasions, or electrical shock (i.e induction cook top).

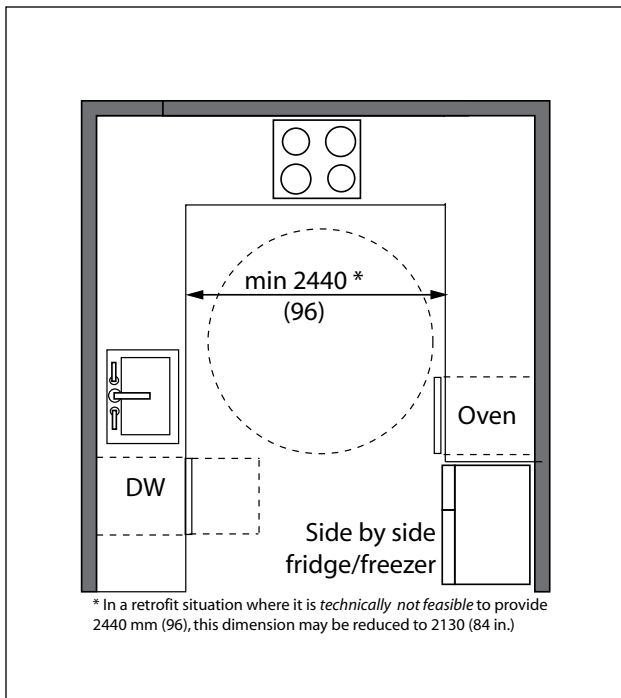

Figure 3.2.4.2 U-Shaped Kitchen

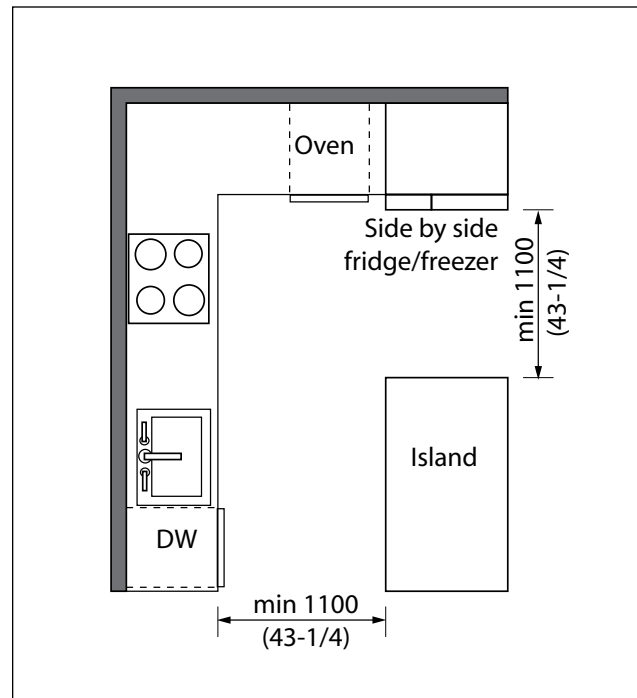

Figure 3.2.4.3 L-Shaped Kitchen with Island

3.2.4 Kitchens and Kitchenettes (continued)

Ovens shall:

- have controls located on the front panels, mounted no higher than 1400 mm (55-1/8 in.);
- where side-hinged doors are used, be located
- with an adjacent work surface positioned adjacent to the latch side of the door; and
- incorporate a pull-out shelf below the oven; and
- where bottom-hinged doors are used, be located with an adjacent work surface positioned adjacent to one side of the door.

All cooking appliances within program areas or rooms being utilized by children should have a secure means of disconnecting power units.

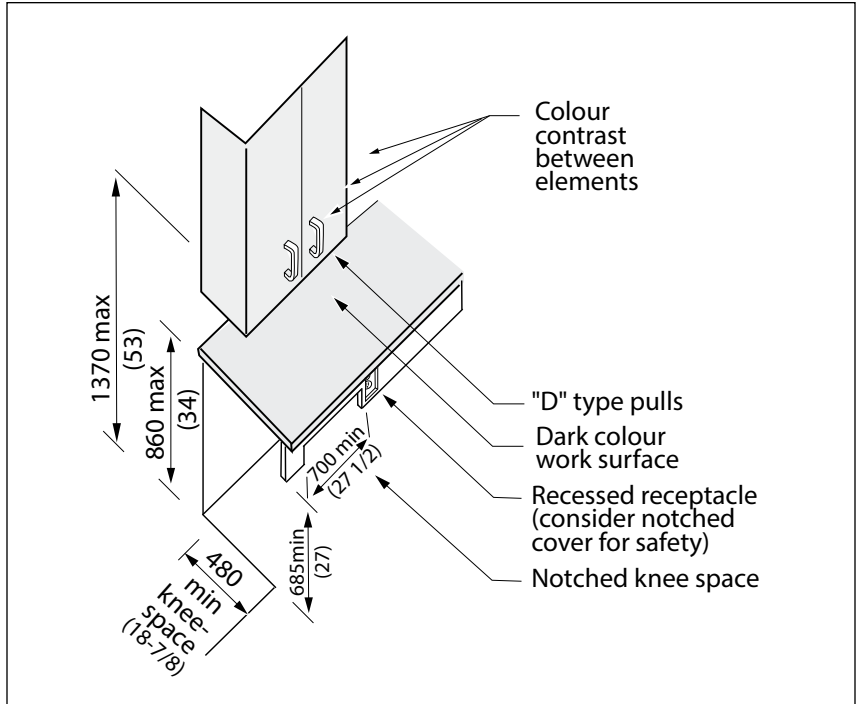

Figure 3.2.4.4 Storage Elements

Refrigerators/freezers shall:

- be configured with at least 50% of the freezer space maximum 1370 mm (54 in.) above the floor; and
- incorporate clear space in front, positioned for a parallel approach immediately adjacent to the refrigerator/freezer, with the centre-line of the clear space offset 610 mm (24 in.) maximum from the front face of the refrigerator/freezer.

All kitchen elements shall incorporate colour contrast to visually differentiate the cabinets and appliances from adjacent wall and floor surfaces, the countertop from the cabinets and adjacent walls, and operable hardware on cabinets.

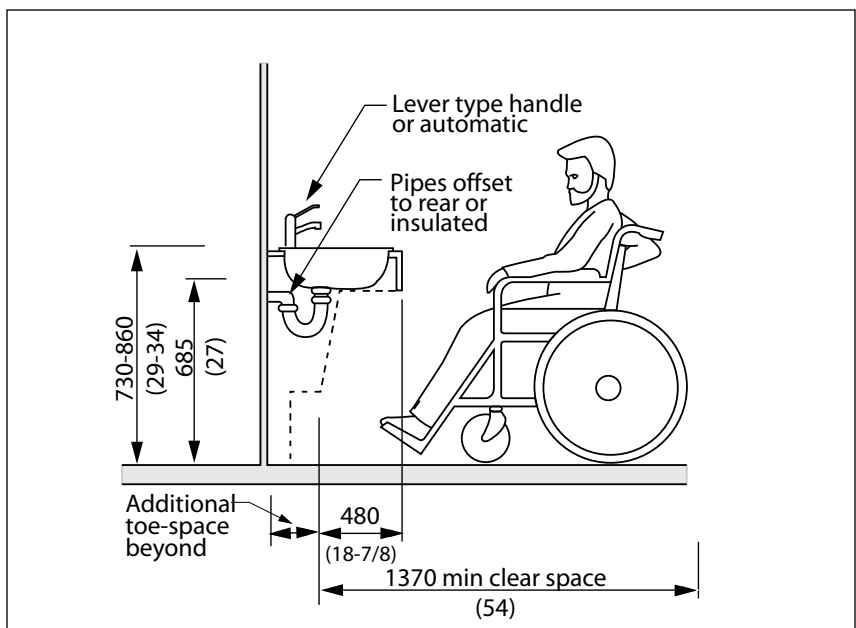

Figure 3.2.4.5 Accessible Kitchen Sink

3.2 INTERIOR AMENITIES

## 3.2.4 Kitchens and Kitchenettes (continued)

### RELATED SECTIONS

- 1.1.1 Space and Reach Requirements
- 1.1.2 Protruding and Overhead Objects
- 1.1.3 Accessible Routes, Paths and Corridors
- 1.2.1 Texture, Finishes and Colour
- 3.1.1 Interior Floor Surfaces
- 3.2.2 Tables, Counters, & Work Surfaces
- 3.2.5 Storage, Shelving & Display Units
- 3.5.1 Controls & Operating Mechanisms
- 3.5.3 Interior Lighting
- 3.5.4 Interior Glare and Light Sources

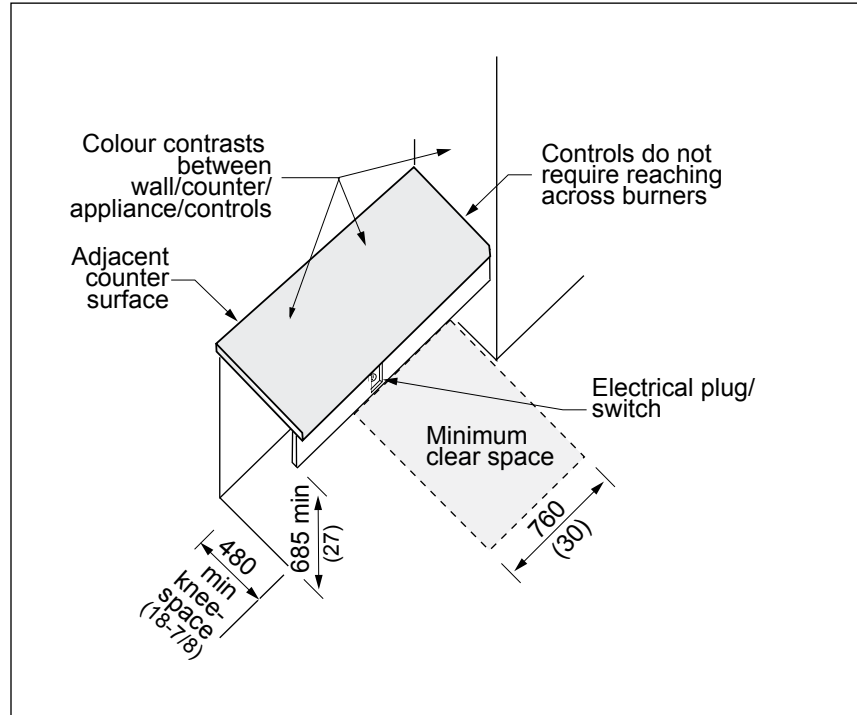

**Figure 3.2.4.6** Accessible Cook Top

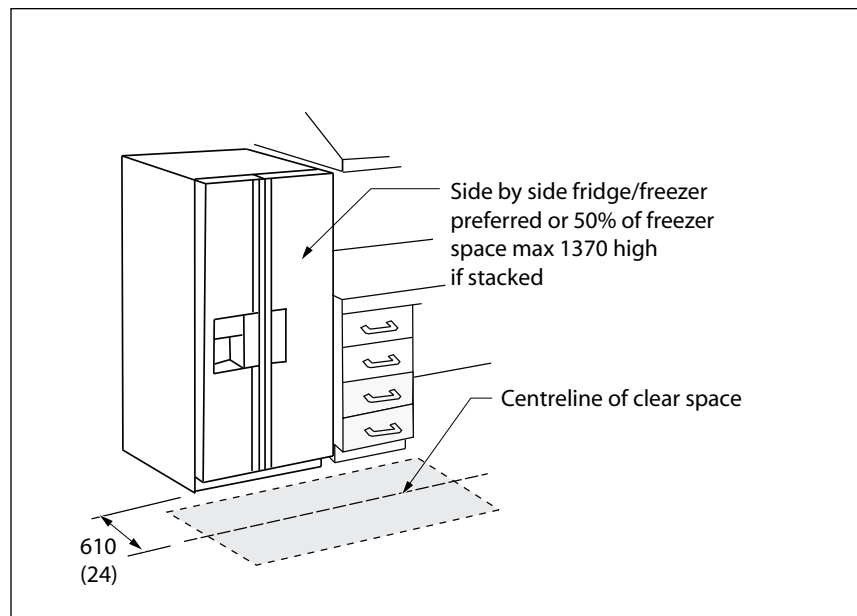

**Figure 3.2.4.7** Accessible Fridge/Freezer



3.2.4 Kitchens and Kitchenettes (continued)

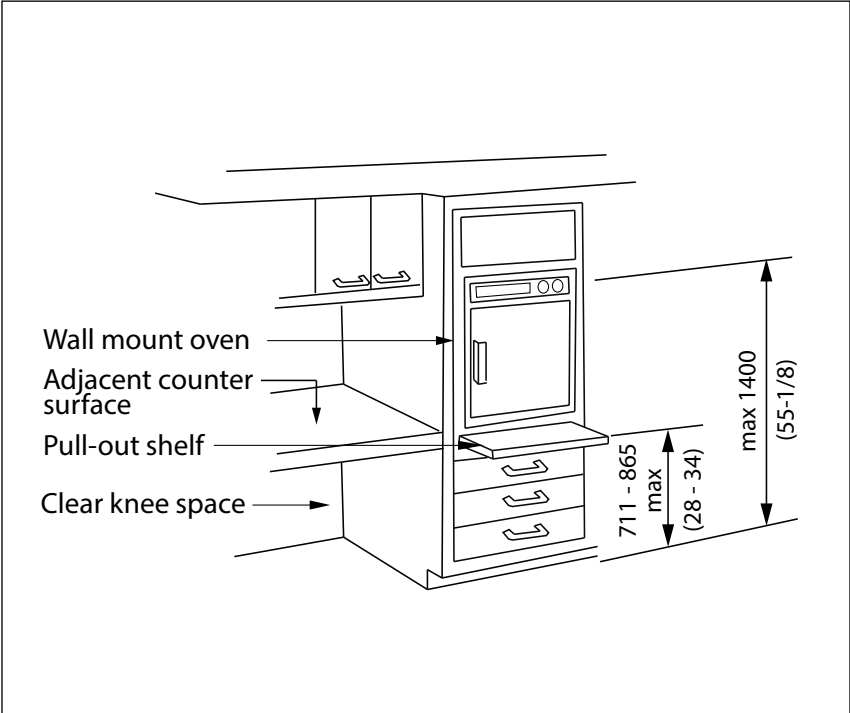

Figure 3.2.4.8 Accessible Wall-Mounted Oven

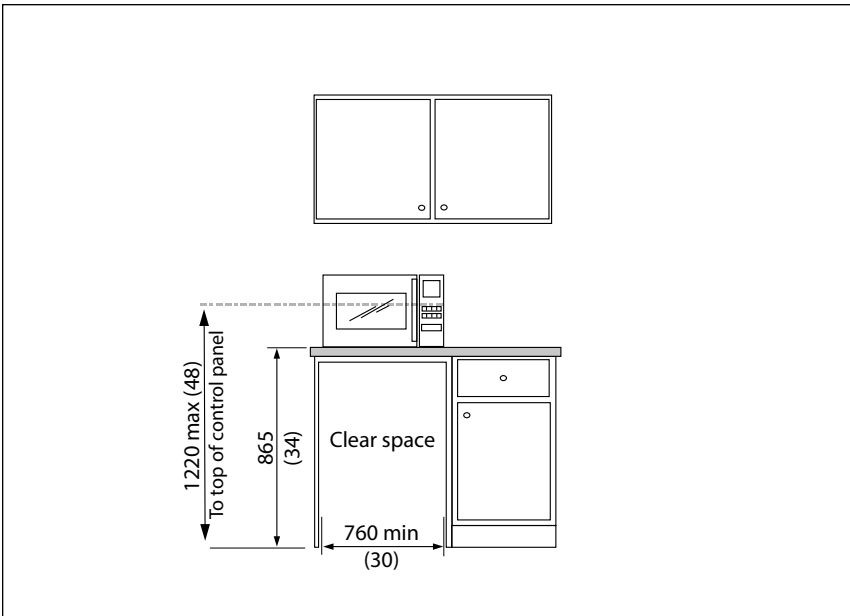

Figure 3.2.4.9 Accessible Microwave

3.2 INTERIOR AMENITIES

## 3.2.5 Storage, Shelving and Display Units

### RATIONALE

The heights of storage shelving, library shelving and display units should address a full range of vantage points including the lower sight lines of children or persons using wheelchairs. The lower heights also serve the lower reach of these individuals. Displays that are too low can be problematic for individuals that have difficulty bending down. Appropriate lighting and *colour contrast* is particularly important for individuals with vision *impairments*.

### APPLICATION

If fixed or built-in storage *facilities*, such as cabinets, closets, shelves and drawers, are provided in *accessible spaces*, at least one of each type provided shall contain storage *space* complying with this

section. This includes media displays areas for brochures, drop-boxes and mail slots.

Shelves or display units allowing self-service by customers shall be located on an *accessible route* complying with Section 1.1.3 Accessible Routes, Paths and Corridors.

### DESIGN REQUIREMENTS

A *clear space* at least 760 mm (30 in.) by 1370 mm (54 in.) complying with Section 1.1.1 Space and Reach Requirements that allows either forward or parallel approach by a person using a wheelchair shall be provided at *accessible storage facilities*.

*Accessible storage spaces* shall be within at least one of the reach ranges specified in Section 1.1.1 Space and Reach Requirements.

Clothes rods or shelves shall be a maximum of 1370 mm (54 in.) above the finished floor for a side approach. Where the distance from the wheelchair to the clothes rod or shelf is 255 mm – 535 mm (10 in. - 21 in.) (as in closets without *accessible* doors) the height of the rod or shelf shall be no more than 1200 mm (47 in.).

Hardware for *accessible storage facilities* shall comply with Section 3.5.1 Controls and Operating Mechanisms. Touch latches and U-shaped pulls are acceptable

### RELATED SECTIONS

- 1.1.1 Space and Reach Requirements
- 1.1.3 Accessible Routes, Paths and Corridors
- 3.5.1 Controls and Operating Mechanisms

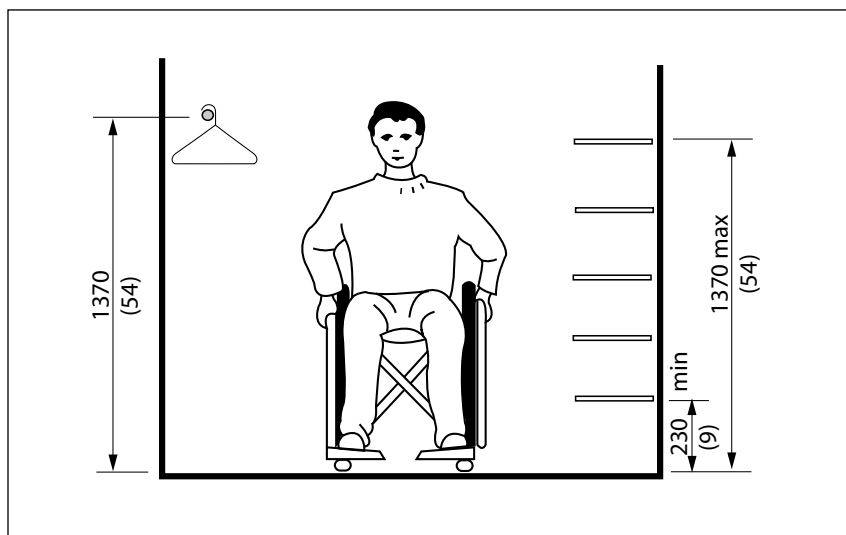

Figure 3.2.5.1 Reach Limits for Storage

### 3.2.6 Universal Change Rooms

#### RATIONALE

In addition to *accessible common use* dressing rooms, a separate unisex dressing room is useful. This is valuable in a scenario where an attendant of another sex or a parent is assisting a child or when a person transcends the social norms of sex and/or gender identity. Sufficient space should be allowed for two people and a wheelchair, along with benches and accessories.

The provision of *handrails* along circulation routes from dressing rooms to pool, gymnasium and other activity areas, will be of benefit to many people.

#### APPLICATION

Where dressing rooms are provided for use by the general public, patients, customers or employees, they shall comply with this section. In a *retrofit* situation where it is *technically not feasible* to have all dressing rooms comply with this section, 10% of dressing rooms, but never less than one, for each type of use in each cluster of dressing rooms shall be *accessible* and comply with this section.

Where a facility incorporates multi-user dressing rooms with integral washroom and shower facilities, at least 10% of the multi-user dressing rooms, but never less than one, shall incorporate a private dressing room in compliance with this section.

#### DESIGN REQUIREMENTS

Universal change rooms shall be located on an *accessible route* complying with Section 1.1.3 Accessible Routes, Paths and Corridors.

All universal change rooms shall include an emergency call station that activates an external light above the door to alert persons to emergency situations.

A *clear space* allowing a person using a wheelchair to make a 180-degree turn shall be provided within every universal change room, accessed through either a hinged or sliding door. No door shall swing into any part of the required turning *space* within the dressing room. Turning *space* is not required within a private dressing room accessed through a curtained opening at least 950 mm (37-1/2 in.) wide, if *clear space* complying with Section 1.1.1 Space and Reach Requirements renders the dressing room usable by a person in a wheelchair.

All doors to universal change rooms shall be in compliance with Section 3.1.3 Doors. Outward swinging doors shall not constitute a hazard to persons using adjacent circulation routes and they shall be power operated.

Every universal change room shall have a 760 mm (30 in.) x 1830 mm (72 in.) bench fixed to the wall along the longer dimension. The bench shall:

- be mounted 450 mm - 500 mm (17-3/4 in. - 19-5/8 in.) above the finished floor;
- have *clear space* not less than 760 mm (30 in.) by 1370 mm (54 in.), provided alongside the bench to allow a person using a wheelchair to make a parallel transfer onto the bench;
- be designed to carry a minimum load of 2.66 kN (600 lb.); and
- where installed in conjunction with showers, swimming pools, or other wet locations, be designed so that:
  - water shall not accumulate upon the surface of the bench; and
  - have a slip-resistant top surface.

The *accessible* change bench shall be equipped with a grab bar that:

- complies with Section 3.3.8 Grab Bars; and
- is L-shaped with 760 mm (30 in.) long horizontal and vertical components mounted with the horizontal component 630 mm - 690 mm (24-3/4 in. - 27-1/8 in.) above the floor and the vertical component 150 mm (6 in.) in front of the bench.

At least one waste receptacle, collapsible coat hook and shelf must be reachable from the *accessible* bench.

Where mirrors are provided in dressing rooms of the same use, then in an universal change

## 3.2.6 Universal Change Rooms (continued)

room, a full-length mirror measuring at least 460 mm (18 in.) wide by 1370 mm (54 in.) high shall be mounted in a position affording a view to a person on the bench, as well as to a person in a standing position.

Dressing rooms shall incorporate even illumination throughout of at least 100 lux (10 ft-candles).

### RELATED SECTIONS

- 1.1.1 Space and Reach Requirements
- 1.1.2 Protruding and Overhead Objects
- 1.1.3 Accessible Routes, Paths and Corridors
- 1.2.1 Texture, Finishes and Colour

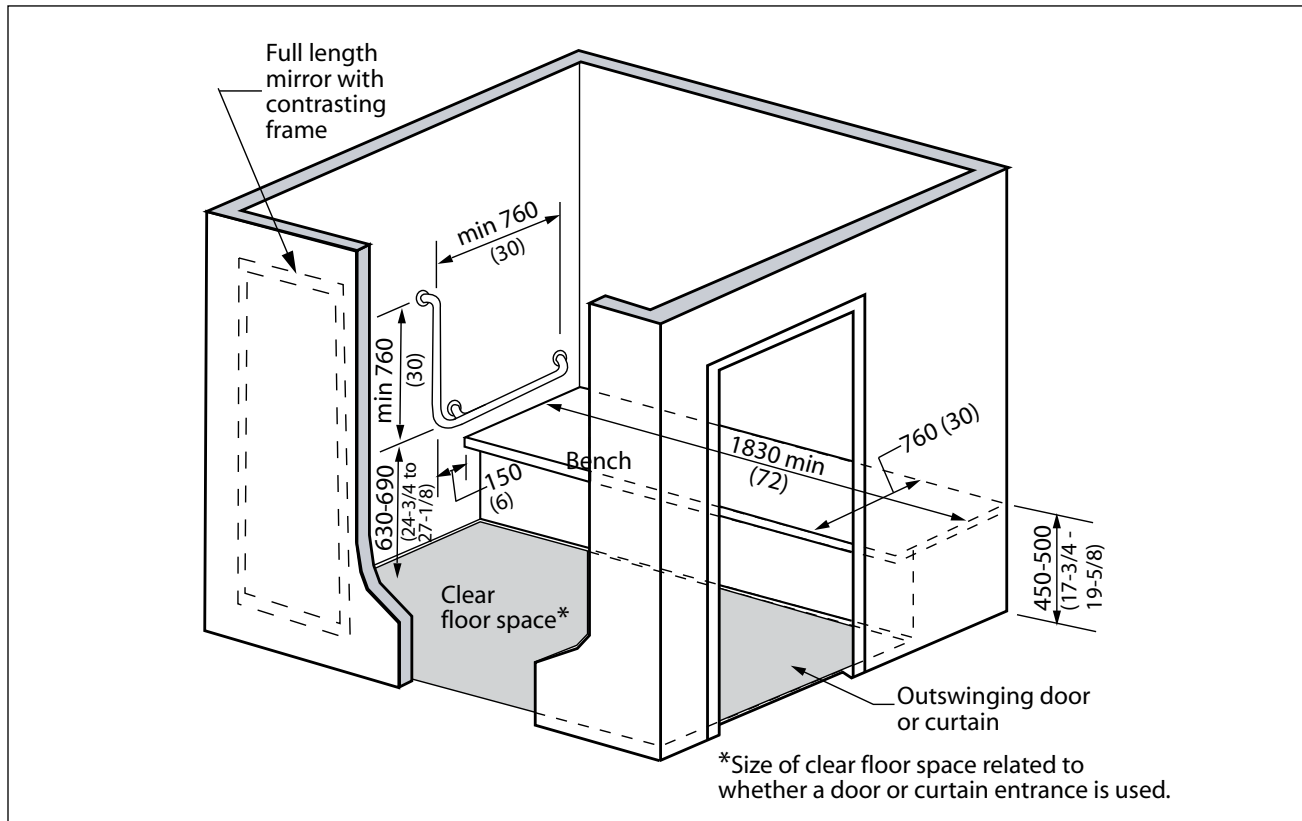

Figure 3.2.6.1 Universal Change Room

### 3.2.7 Lockers and Storage Units

#### RATIONALE

In training, paramedic, fire, police, recreational, and transit facilities, or wherever public or private storage lockers are provided, at least some of the storage units should be usable by persons using wheelchairs.

Lockers designed specifically for universal design applications are preferred.

The provision of lockers at lower heights serves the reach restrictions of children or persons using wheelchairs. The operating mechanisms should also be at an appropriate height and operable by individuals with restrictions in hand dexterity.

#### APPLICATION

If lockers or baggage storage units are provided in *accessible* public or *common use* areas, at least 10%, but not less than one, of the lockers or baggage storage units shall comply with this section.

#### DESIGN REQUIREMENTS

*Accessible* locker units shall be located on an *accessible route* complying with Section 1.1.3 Accessible Routes, Paths and Corridors.

Locker units shall have their bottom shelf no lower than 400 mm (15-3/4 in.) and their top shelf no higher than 1370 mm (54 in.) above the floor or ground.

Locks for *accessible* locker units shall be mounted no higher than 1060 mm (42 in.) from the floor or ground and shall comply with Section 3.5.1 Control and Operating Mechanisms.

Numbers or names on locker units should be in clearly legible lettering, raised and of a highly contrasting colour or tone in compliance with the relevant parts of Section 1.2.4 Signage.

Aisle *spaces* in front of lockers and storage units shall be a minimum of 1370 mm (54 in.) deep to permit forward and lateral approach by wheelchair users.

#### RELATED SECTIONS

- 1.1.1 Space and Reach Requirements
- 1.1.3 Accessible Routes, Paths and Corridors
- 1.2.1 Texture, Finishes and Colour
- 1.2.4 Signage
- 2.1.2 Exterior Lighting
- 3.5.1 Controls and Operating Mechanisms
- 3.5.3 Interior Lighting

Total number of lockers	Minumum number of accessible lockers
1-5	1
6-10	2
11-25	4
26-35	6
36+	10

**Table 3.2.7.1** Accessible Locker Requirements

### 3.2 INTERIOR AMENITIES

# INTERIOR STANDARDS

## 3.3.1 Toilet Facilities

### RATIONALE

As an integral feature of a *facility*, washroom *facilities* should accommodate the range of people that will use the *space*. In some cases, a person with a *disability* may require assistance to use toilet *facilities*. Where the individual providing assistance is of another gender, typical gender-specific washrooms are awkward and an individual washroom is preferred. Another scenario is accommodating people for whom single sex toilet facilities are not comfortable to enter and use.

Wet surfaces and the act of transferring between toilet and wheelchair can make bathrooms accident-prone areas. Therefore, emergency call switches may ensure related response procedures. The appropriate design of all features will increase the usability and safety of the *space*.

Signs that are used to identify washrooms should consider the needs of a variety of users. For children or someone who cannot read text, a symbol is required.

A person with a vision *impairment* would also benefit from accessible *signage*. Features such as *colour contrasting* door frames and door hardware will also increase accessibility.

Washroom *entrances* that do not incorporate doors are preferred.

### APPLICATION

Where toilet *facilities* are provided, each public or *common use* toilet *facility* shall comply with this section. Other toilet rooms provided for the use of occupants of specific *spaces* (i.e., a private toilet room for the occupant of a private office) shall be *adaptable*.

In a *retrofit* situation where it is *technically not feasible* to make existing public or *common use* toilet *facilities* *accessible*, the installation of at least one individual washroom per floor com-

plying with Section 3.3.7 Individual Washrooms is permitted. This individual washroom should be located adjacent to the other existing toilet *facilities*. At minimum, MBC must be followed for all washroom facilities in accordance with occupancy load and facility type.

At least one individual washroom that is gender neutral complying with Section 3.3.7 shall be provided on every floor in *assembly areas* where the floor incorpo-

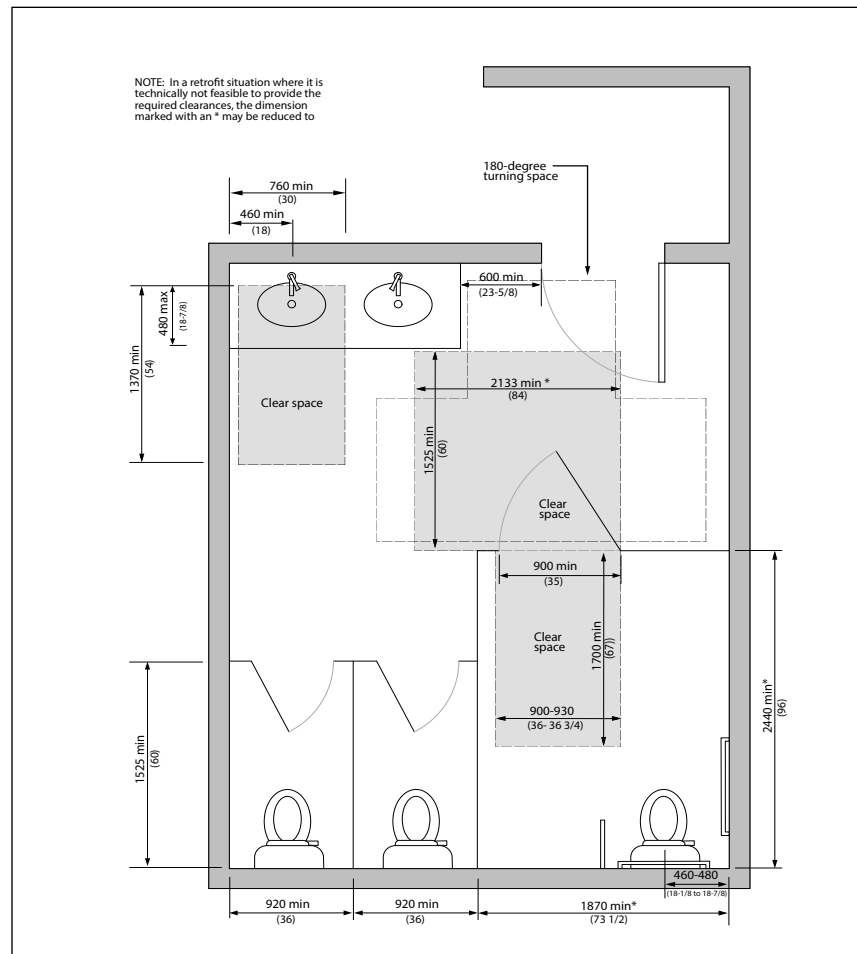

Figure 3.3.1.1 Washroom Dimensions

## 3.3 WASHROOM FACILITIES

**3.3.1 Toilet Facilities (continued)**

rates public or *common use* toilets. The individual washroom must be proximate to the public washrooms of all public *buildings* (within 15 m or 50 ft.).

If individual washrooms are not visible from the common or *public use* washrooms, directional *signage* complying with section 3.3.7 Individual Washrooms, shall be provided.

Where an individual washroom is provided primarily for the gender neutral use of persons with physical *disabilities*, in lieu of *facilities* for persons with physical *disabilities* within a bank of washroom stalls used by the general public, the individual washroom can be substituted for one non-accessible stall in the public washroom provided it is on the same floor level and within 15 m (50 ft.) of the bank of washrooms used by the general public.

For single-user portable toilets or clustered at a single location, at least 5%, but no less than one, toilet complying with this section shall be provided at cluster wherever typical inaccessible units are provided. Exception: Portable toilet units at construction *sites* used exclusively by construction personnel are not required to comply with this section.

**DESIGN REQUIREMENTS**

All requirements of the National Building Code and MBC 3.8.2.3 must be met. *Accessible* toilet *facilities* shall be on an *accessible route* complying with Section 1.1.3 Accessible Routes, Paths

and Corridors.

All doors to *accessible* toilet rooms shall comply with Section 3.1.3 Doors. Doors shall not swing into the *clear space* required for any fixture. All main washroom doors must include an automatic door operator when accessible stalls or a universal toilet room are present.

The *accessible* fixtures and controls within toilet *facilities* shall be located on an *accessible route* which is at least 1200 mm (47-1/4 in.) wide and in compliance with Section 1.1.3 Accessible Routes, Paths and Corridors.

Toilet *facilities* shall incorporate *clear space* in compliance with 1.1.1 Space and Reach Requirements, in front of *accessible* toilet stall doors and in front of *accessible* lavatories to allow a person in a wheelchair or scooter to make a 180-degree turn.

*Accessible* toilet *facilities* shall be identified with *signage* complying with applicable provisions of Section 1.2.4 Signage.

Toilet *facilities* shall incorporate even illumination throughout of at least 100 lux (10 ft-candles).

An infant changing area shall be provided in single occupant washrooms if an adult change bench is not provided and in multiple occupant washrooms (both male and female). In multiple occupant washrooms they shall be located outside of the accessible stall.

The infant changing station shall comply with Sections 1.1.1 General Space and Reach Requirements, 1.1.2 Protruding and Overhead Objects, and 3.5.1 Controls and Operating Mechanisms.

To be accessible they must allow for clear space complying with Figure 3.3.1.1 and Figures 1.1.1.13 – 1.1.1.15 Wheelchair Forward Reach Allowances, and Figure 3.2.2.1 Table, Counter and Work Surface Clearance. The top surface should be 700 mm (27 in.) minimum and 865 mm (34 in.) maximum in height above the finished floor. They shall be a minimum of 915 mm (36 in.) long and 610 mm (24 in.) deep.

**RELATED SECTIONS**

- 1.1.1 Space and Reach Requirements
- 1.1.2 Protruding and Overhead Objects
- 1.2.1 Texture, Finishes and Colour
- 1.2.4 Signage
- 2.1.1 Exterior Ground Surfaces
- 3.1.3 Doors
- 3.2.2 Tables, Counters, and Work Surfaces
- 3.2.5 Storage, Shelving and Display Units
- 3.3.2 Toilet Stalls
- 3.3.3 Toilets
- 3.3.4 Lavatories
- 3.3.5 Urinals
- 3.3.6 Washroom Accessories
- 3.3.7 Individual Washrooms
- 3.3.8 Grab Bars
- 3.3.9 Shower Stalls
- 3.4.1 Visual Alarms
- 3.5.1 Controls and Operating Mechanisms
- 3.5.3 Interior Lighting

**3.3 WASHROOM FACILITIES**

# INTERIOR STANDARDS

## 3.3.2 Toilet Stalls

### RATIONALE

Maneuverability of a wheelchair or scooter is a principal consideration in the design of an accessible stall. The increased size of the stall is required to ensure there is sufficient *space* to facilitate the proper placement of a wheelchair or scooter to accommodate a transfer onto the toilet fixture. Not only is *space* required for the mobility equipment but there may also be instances where an individual requires assistance and the stall will have to accommodate a second person.

Door swings are normally outward for safety reasons and *space* considerations, but this makes it difficult to close the door once inside. A handle mounted part way along the door makes it easier for someone to close the door behind them.

Minimum requirements for non-*accessible* toilet stalls are included to ensure that persons who do not use wheelchairs or scooters can be adequately accommodated within any toilet stall. Universal features include *accessible* hardware and minimum a stall width to accommodate persons of large stature.

A different coloured door on the accessible stall can be used to identify uniqueness without labeling disability.

### APPLICATION

If toilet stalls are provided in a toilet or bathing *facility*, then the number of *accessible* toilet stalls designated to accommodate persons with *disabilities* shall comply with Table 3.3.2.1.

*Accessible* toilet stalls shall comply with this section.

All other toilet stalls within a facility (i.e., those considered to be non-*accessible*) shall be minimum 920 mm (36 in.) wide by 1525 mm (60 in.) long, and shall incorporate door-locking mechanisms in compliance with this section.

### DESIGN REQUIREMENTS

*Accessible* toilet stalls shall:

- be on an *accessible route* complying with Section 1.1.3 Accessible Routes, Paths and Corridors;
- have internal clear turning space of at least 1700 x 1700 mm (67 in. x 67 in.).

In a *retrofit* situation where providing the required internal clear turning space is *technically not feasible*, the internal clear turning space may be reduced to a minimum of 1600 mm deep x 1500 mm wide (63 in. x 59 in.) (MBC);

- have a toilet complying with Section 3.3.3 Toilets; and
- be equipped with a collapsible coat hook mounted not more than 1200 mm (47 in.) from the floor on a side wall and projecting not more than 50 mm (2 in.) from the wall.

Toilet stall doors shall:

- be capable of being locked from the inside by a device that is operable with one hand; does not require fine finger control, tight grasping, pinching, or twisting of the wrist; requires a force of not more than 22 N (4.9 lb.) to activate (e.g., sliding bolt or lever); and can be opened from the outside in an emergency situation by an authorized person.
- provide a *clear* opening of at least 900 mm (35 in.) with the door in the open position.

# of toilet stalls within the washroom	Required # of <i>accessible</i> toilet stalls
1-5	1
More than 5	2

Table 3.3.2.1 Number of Accessible Toilet Stalls



## 3.3.2 Toilet Stalls (continued)

In a *retrofit* situation where it is *technically not feasible* to provide the required *clear* opening, the *clear* opening may be reduced to 810 mm (32 in.);

- swing outward, unless additional *clear space* of at least 760 mm x 1370 mm (30 in. x 54 in.) is provided within the stall, out with the arc of the door swing;
- be aligned with the *clear space* adjacent to the toilet fixture;
- be equipped with gravity hinges so that the door closes automatically;
- be provided with a “D”-type *colour contrasting* door pull, at least 140 mm (5-1/2 in.) long, on the inside of an out-swinging door, located so that the centre line is between 200 and 300 mm (7-7/8 in. and 11-3/4 in.) from the hinged side of the door, located 900 mm (35-1/2 in.) above the finished floor; and
- be provided with a “D”-type *colour contrasting* door pull at least 140 mm (5-1/2 in.) long, on both sides of the door, located near the latch, 900 mm (35-1/2 in.) above the finished floor.

Where more than one *accessible* toilet stall is provided within a washroom, at least one *accessible* stall shall be configured to provide the required *transfer space* on the left side of the toilet fixture, and at least one *accessible* stall shall be configured to provide the required *transfer space* on the right side of

the toilet fixture.

The *transfer space* adjacent to the toilet fixture, as required by Section 3.3.3 Toilets, shall be *clear* of obstructions (such as garbage bins or baby change tables).

Toilet stall doors shall be *colour contrasted* with the toilet partitions.

### RELATED SECTIONS

- 1.1.1 Space and Reach Requirements
- 1.1.2 Protruding and Overhead Objects
- 1.2.1 Texture, Finishes and Colour
- 3.1.3 Doors
- 3.3.3 Toilets
- 3.3.6 Washroom Accessories
- 3.3.8 Grab Bars
- 3.5.1 Controls and Operating Mechanisms
- 3.5.3 Interior Lighting

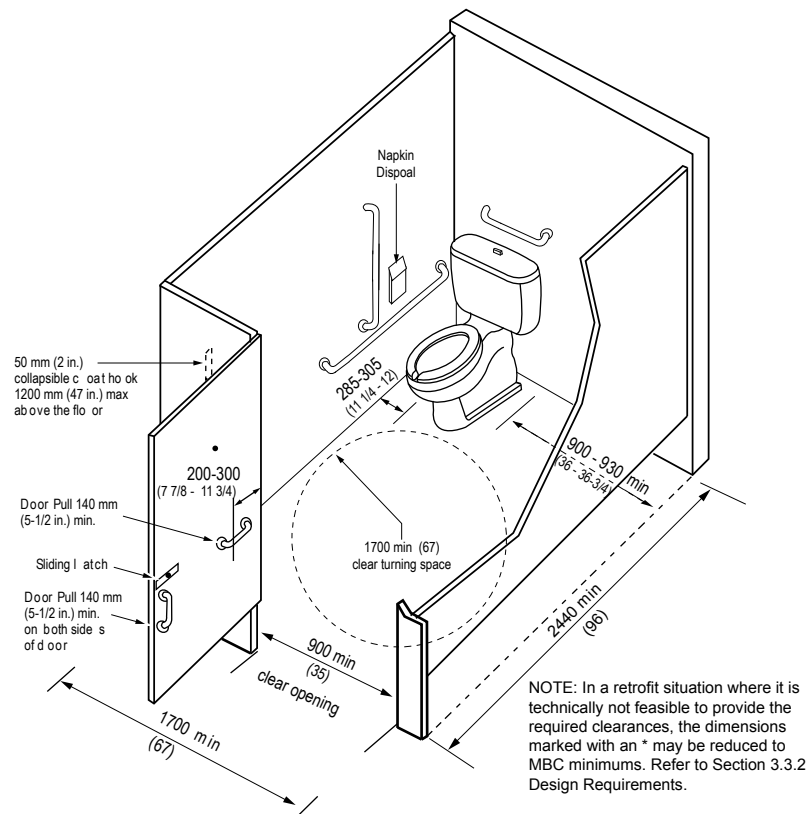

Figure 3.3.2.1 Accessible Toilet Stall

## 3.3 WASHROOM FACILITIES

# INTERIOR STANDARDS

## 3.3.3 Toilets

### RATIONALE

Automatic low flush toilet controls are preferred. If flushing mechanisms are not automated, then consideration must be given to the ability to reach a switch and the hand strength or dexterity to operate it. Lever style handles on the transfer side of the toilet facilitate this. Appropriate placement of grab bars makes sitting and standing or transfers between toilet and wheelchair safer.

### APPLICATION

*Accessible* toilets shall comply with this section.

### DESIGN REQUIREMENTS

Toilet fixtures shall have:

- the top of the seat between 400 mm and 460 mm (15-3/4 in. and 18-1/8 in.) from the floor;
- no spring-activated seat;
- a back support where there is no seat lid or tank; and
- the tank top securely attached with a tamper proof bolt.

Toilets shall be located so that the clearance between the fixture and the wall on one side is 285 mm - 305 mm (11-1/4 in. - 12 in.). A minimum 920 mm (36 in.) - wide transfer *space* shall be provided on the other side of the toilet fixture. In multiple story buildings, the transfer space should be alternated every second floor to accommodate left and right sided transfers. In a *retrofit* situation where it is *technically not feasible*

to provide a 920 mm (36 in.)-wide transfer *space*, the *space* may be reduced to 760 mm (30 in.).

The transfer *space* shall be clear of obstructions (such as garbage bins or baby change tables).

Toilet flush controls shall either:

- be electronically automatically controlled;
- be hand-operated on the transfer side of the toilet in compliance with Section 3.2.2 Tables, Counters and Work Surfaces; or
- include an assistive flushing mechanism or lever if dual flush.

Toilets shall be equipped with grab bars that:

- comply with Section 3.3.8 Grab Bars;
- are mounted horizontally on the side wall closest to the toilet fixture, extending not less than 450 mm (17-3/4 in.) in both directions from the most forward point of the toilet fixture, 840 mm - 920 mm (33 in. - 36 in.) above the floor;
- are at least 760 mm (30 in.) long, mounted vertically on the side wall closest to the toilet fixture, 150 mm (5-7/8 in.) in front of the most forward point of the toilet fixture, with its lowest edge no closer than 60 mm (2-3/8 in.) above the horizontal bar; and
- are at least 600 mm (23-5/8 in.) in length, mounted horizontally on the wall behind

the toilet fixture, centred on the toilet bowl, 840 mm - 920 mm (33 in. - 36 in.) above the floor.

When a toilet-paper dispenser is provided, the dispenser shall:

- be wall mounted;
- have a maximum reach distance to the furthest roll of 686 mm (27) from the toilet
- be located below the grab bar, with its highest surface no closer than 60 mm (2-3/8 in.) from the horizontal bar;
- dispense paper 0 - 686 mm (0 - 27 in.) in front of the toilet seat and not less than 600 mm (23-5/8 in.) above the floor; and
- be contrasting in colour to the wall.

NOTE: It is optional to use smaller dispensers for the accessible washroom.

### RELATED SECTIONS

- 1.1.1 Space and Reach Requirements
- 1.2.1 Texture, Finishes and Colour
- 3.3.2 Toilet Stalls
- 3.3.8 Grab Bars
- 3.5.1 Controls and Operating Mechanisms
- 3.5.3 Interior Lighting

## 3.3 WASHROOM FACILITIES



# INTERIOR STANDARDS

## 3.3.4 Lavatories

### RATIONALE

The accessibility of lavatories will be greatly influenced by their operating mechanisms. Use of faucets incorporating infrared technology are preferred. For an individual in a wheelchair, a lower counter height and clearance for knees under the counter is required. This lower counter may also serve children.

### APPLICATION

All lavatories shall comply with this section. In a *retrofit* situation where it is *technically not feasible* to have all lavatories comply with this section, at least one lavatory in each *accessible* washroom shall comply.

### DESIGN REQUIREMENTS

Lavatories shall:

- be on an *accessible route* complying with Section 1.1.3 Accessible Routes, Paths and Corridors;
- be mounted so that the minimum distance between the centre line of the fixture and the side wall is 460 mm (18-1/8 in.);
- have the top located no more than 865 mm (34 in.) from the floor;
- have a knee *space* of at least 760 mm (30 in.) wide;
  - and 735 mm (29 in.) high at the front edge;
  - 685 mm high (27 in.) at a point 205 mm (8-1/8 in.) back from the front edge; and;

- 230 mm (9 in.) high over the distance from a point 280 mm (11 in.) to a point 430 mm (16-7/8 in.) back from the front edge;
- have a minimum *clear space* 760 mm wide (30 in.) and 1370 mm (54 in.) deep, of which a maximum of 480 mm (18-7/8 in.) in depth may be under the lavatory;
- have hot water and drain pipes insulated if they abut the clearances noted above, or have the water temperature limited to a maximum of 43 degrees Celsius (100 degrees F); and
- have soap and towel dispensers that are activated and dispensed using one hand;
- ensure the positioning of the hand dryer is in compliance with 3.5.1;
- be located within 500 mm (19-5/8 in.) reach of a seated person;
- be located so that the dispensing height is not more than 1200 mm (47 in.) above the floor;
- be *colour contrasted* from the surrounding environment; and;
- be in compliance with Section 3.5.1 Controls and Operating Mechanisms.

Faucets and other controls shall:

- be in compliance with Section 3.5.1 Controls and Operating Mechanisms; and
- be located so that the distance from the centre line

of the faucet to the edge of the basin, or where the basin is mounted in a vanity, to the front edge of the vanity is not more than 485 mm (19-1/8 in.).

The front apron of a vanity shall have a minimum clearance of 760 mm (30 in.) wide by 735 mm (29 in.) high.

Shelves or other projections above lavatories shall be located so they will not present a hazard to individuals with vision *impairments*.

There shall be no abrasive surfaces below the vanity.

Where pipes are exposed beneath a sink or vanity they shall be insulated to protect individuals using a wheelchair whose legs may come into contact with hot water pipes.

Where mirrors are provided at lavatories or vanity units, they shall comply with Section 3.3.6 Washroom Accessories.

### RELATED SECTIONS

- 1.1.1 Space and Reach Requirements
- 1.2.1 Texture, Finishes and Colour
- 3.5.1 Controls and Operating Mechanisms
- 3.5.3 Interior Lighting

## 3.3 WASHROOM FACILITIES

3.3.4 Lavatories (continued)

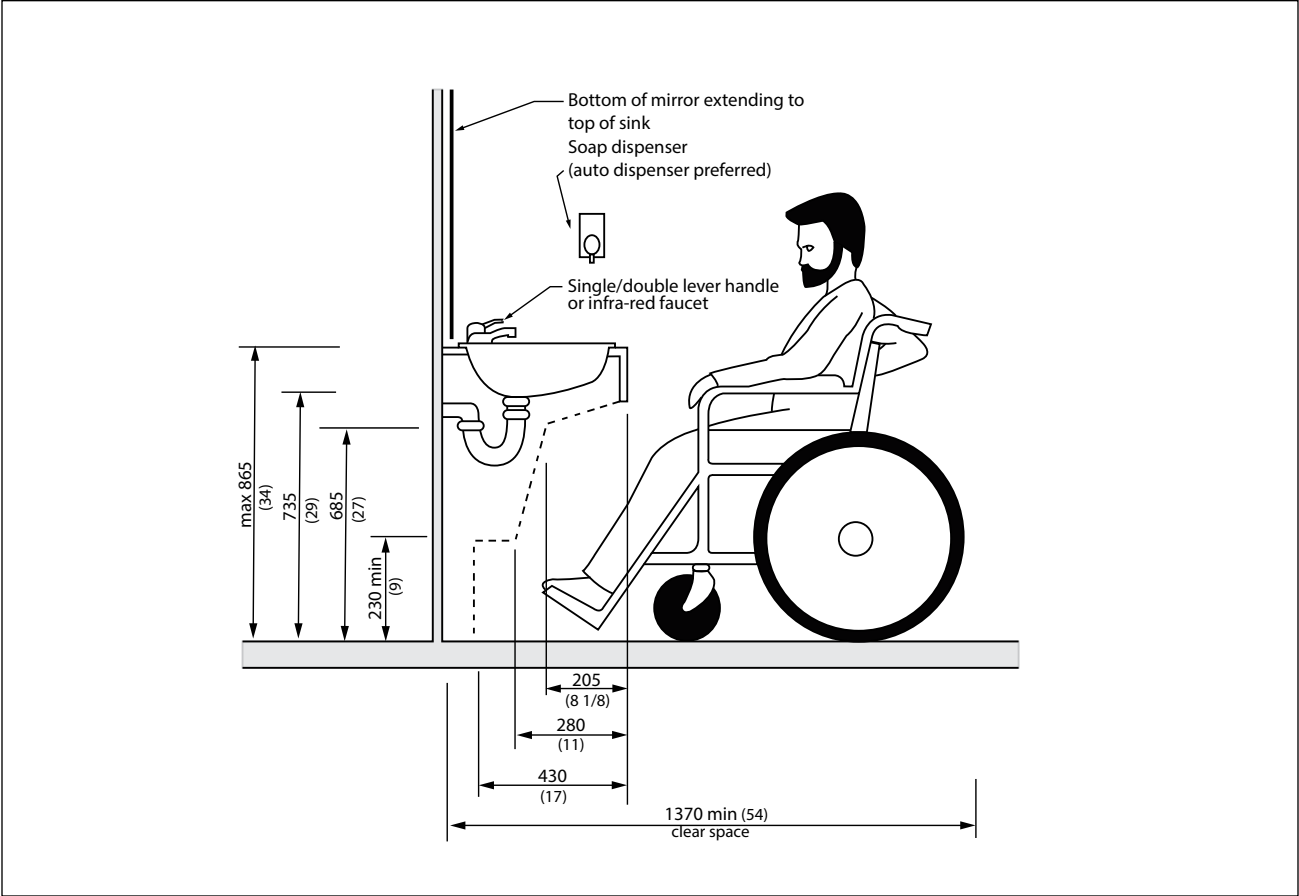

Figure 3.3.4.1 Lavatory Criteria

3.3 WASHROOM FACILITIES

## 3.3.5 Urinals

### RATIONALE

A *clear space* is required in front of urinals to maneuver a mobility device. The provision of grab bars may assist an individual rising from the chair and steady-ing themselves. Floor-mounted urinals accommodate children and persons of short stature as well as making it easier to drain personal care devices. Flush controls should be lever or automatic (preferred). Strong *colour contrast* will assist individuals with vision impairments.

### APPLICATION

Where urinals are provided in an *accessible* toilet or bathing *facility*, at least one shall comply with this section.

### DESIGN REQUIREMENTS

Urinals shall be:

- wall-mounted with the rim located between 430 mm - 512 mm (17 in. - 20-1/8 in.) from the finished floor; or
- floor-mounted, with the rim level at the finished floor.

A *clear space* of 760 mm x 1370 mm (30 in. x 54 in.) shall be provided in front of the urinal to allow for a forward approach. This *clear space* shall adjoin or overlap an *accessible route* and shall comply with Section 1.1.1 Space and Reach Requirements.

The urinal shall have grab bars installed on each side that:

- are vertically mounted
  - are not less than 600 mm (23-5/8 in.) long
  - have their lower end located 600 mm - 650 mm (23-5/8 in. - 25-1/2 in.) above the floor
  - are no more than 380 mm (15 in.) from the centre line of the urinal
  - are located not more than 380 mm (15 in.) from the centre line of the urinal; and
  - comply with Section 3.3.8 Grab Bars..
- Flush controls shall be auto flusher controlled or hand-operated at no more than 1120 mm (44 in.) above the finished floor, and shall comply with Section 3.5.1 Controls and Operating Mechanisms.

Where privacy screens are provided:

- there shall be at least 920 mm (36 in.) of clearance between them; and
- they shall incorporate a pronounced *colour contrast* to

Where a washroom contains more than three urinals, one urinal shall be:

- installed with the rim no higher than 335 mm (14 in.) from the finished floor: or

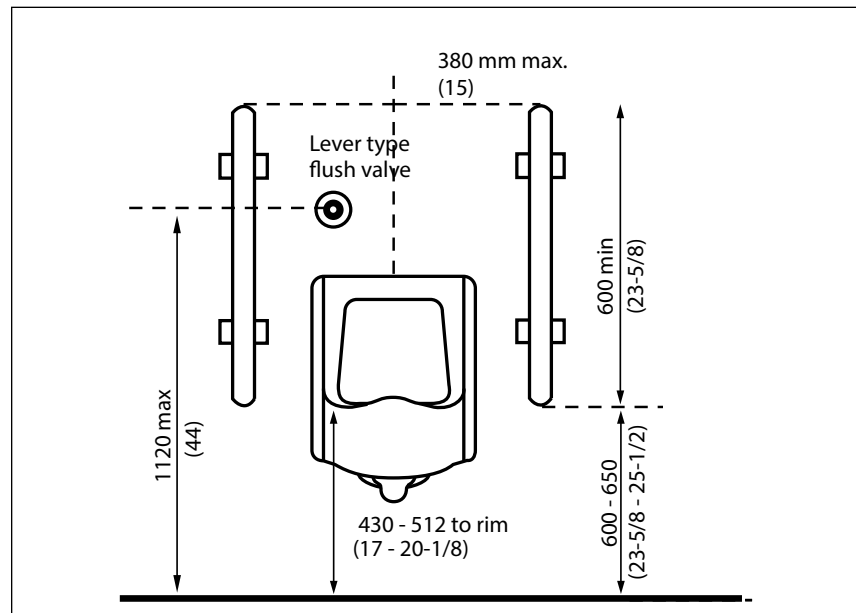

Figure 3.3.5.1 Front Approach to Urinal

### 3.3.5 Urinals (continued)

- floor-mounted, with the rim level at the finished floor.

•

#### RELATED SECTIONS

- 1.1.1 Space and Reach Requirements
- 1.2.1 Texture, Finishes and Colour
- 3.5.1 Controls and Operating Mechanisms
- 3.5.3 Interior Lighting

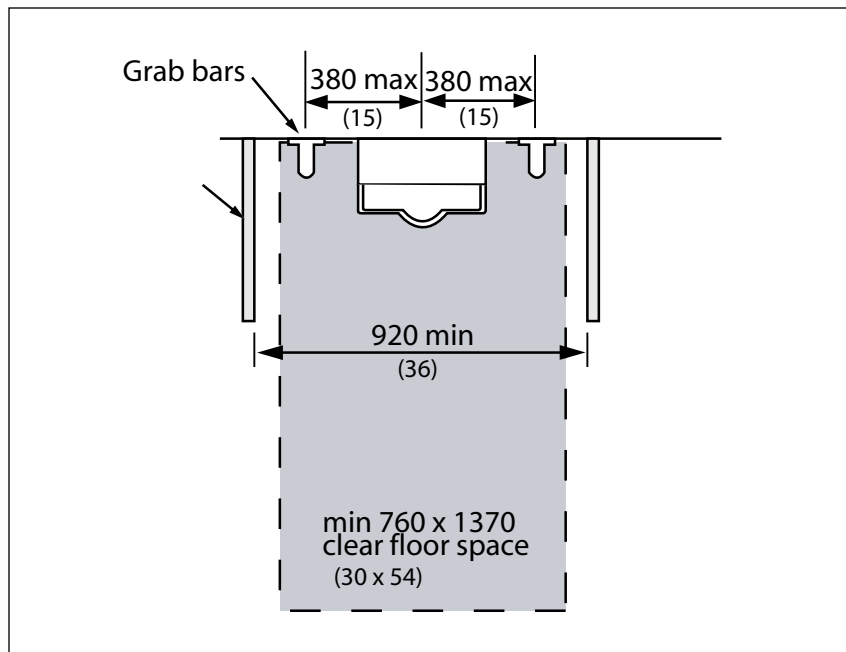

**Figure 3.3.5.2** Approach of Urinal

## 3.3 WASHROOM FACILITIES

## 3.3.6 Washroom Accessories

### RATIONALE

Washroom accessories and mechanisms often require hand strength and dexterity to operate. As a result, automatic activation dispensers are preferred.

Accessories that require the use of two hands to operate can present difficulties for a range of persons with *disabilities* when the ability to reach or balance is impaired. Refer to Section 3.5.1 Controls and Operating Mechanisms for greater detail.

### APPLICATION

Where washroom accessories are provided in a toilet or bathing *facility*, they shall comply with this section. In a *retrofit* situation where it is *technically not feasible* to make all washroom accessories comply with this section, at

least one of each type of washroom accessory shall comply in all *accessible* toilet or bathing *facilities*. A requirements for Automatic Door Operators at all the entrances to Individual Washrooms.

### DESIGN REQUIREMENTS

Automatic hands-free designs are preferred.

Each type of washroom accessory provided, except those located in toilet stalls as specified in Section 3.3.2 Toilet Stalls and in lavatories as specified in Section 3.3.4 Lavatories, shall have *operable portions* and controls mounted between 900 mm (35 in.) and 1200 mm (47 in.) from the floor.

Accessories mounted over a

counter shall not require a forward reach of more than 600 mm (23-5/8 in.). Items such as soap dispensers are preferably mounted within 255 mm (10 in.) max. for sideways reach.

The operable controls and mechanisms of washroom accessories shall comply with Section 3.5.1 Controls and Operating Mechanisms.

Where mirrors are provided, at least one shall be mounted with its bottom edge not more than 1000 mm (39-3/8 in.) from the floor.

Where a full length mirror is provided, it shall:

- incorporate a *clear* floor area in front, at least 760 mm (30 in.) wide x 1370 mm (54 in.) deep;

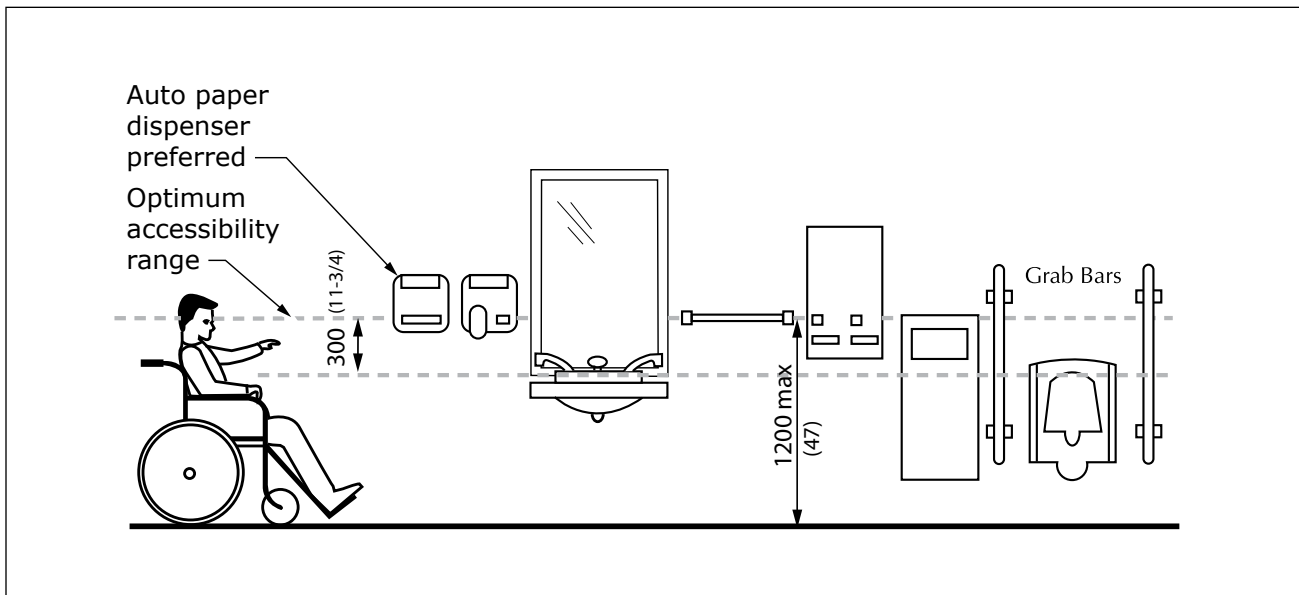

Figure 3.3.6.1 Washroom Accessories



## 3.3.6 Washroom Accessories (continued)

- be mounted with its lower edge 460-600 mm (18 - 23-1/2 in.) above the floor; and
- extend to at least 1830 mm (72 in.) above the floor.

### RELATED SECTIONS

- 1.1.1 Space and Reach Requirements
- 1.1.2 Protruding and Overhead Objects
- 1.2.1 Texture, Finishes and Colour
- 3.5.1 Controls and Operating Mechanisms
- 3.5.3 Interior Lighting

## 3.3.7 Universal Toilet Rooms

### RATIONALE

The provision of a separate individual washroom is advantageous for several reasons. An individual washroom is usable by all genders. For an individual using a wheelchair, the extra *space* provided with a separate washroom is preferred to an accessible stall. Should an individual require an attendant to assist them in the washroom then the complication of a woman entering a men's washroom or vice versa is avoided. This same scenario would apply to a parent with a young child of a different gender.

In the event of an accident or fall by a single individual in this form of washroom, an emergency call switch and a means of unlocking the door from the outside are important safety features.

An adult change platform/bench or a fold down adult change table is required in places of assembly (i.e. arenas, libraries, community centres, pools, recreation centres, etc.). (see Figure 3.3.7.2) Height adjustment features are optional.

### APPLICATION

Individual washrooms shall be provided as required by Section 3.3.1 Toilet Facilities. They shall meet all the minimum requirements of 3.8.2.3 and 3.8.3.12 of MBC, but also must meet the requirements for *accessible* individual washrooms within this section for all facility types.

A minimum of one universal toilet room conforming with, this section (3.3.7) shall be provided on each floor of a building where washrooms are located (MBC Amendments 3.8.2.3)

High use assembly buildings require a minimum of one individual washroom that will include a change bench and emergency call system (per Figure 3.3.7.2).

Where it is technically not feasible to accommodate an individual washroom complying with Figure 3.3.7.2 in a retrofit situation or within an employee space, in a heritage building or a building smaller than 600 sq. m. and where there is a universal toilet room on the same level in a public space that complies with Figure 3.3.7.2, it is acceptable to provide an employee universal toilet room that is in compliance with, at minimum Figure 3.3.7.1) All requirements of MBC must be met.

### DESIGN REQUIREMENTS

*Accessible* individual washrooms shall be on an *accessible route* complying with Section 1.1.3 Accessible Routes, Paths and Corridors.

*Accessible* individual washrooms shall be identified with *signage* complying with applicable provisions of Section 1.2.4 Signage.

Where infant change stations are required in individual washrooms, they shall comply with the

requirements as outlined in Section 3.3.1 Toilet Facilities.

Individual washrooms shall:

- meet all the requirements of Figure 3.3.7.2
- be designed to permit a wheelchair to turn unobstructed within a *clear space* that has a diameter of not less than 1930 mm (76 in.);
- be equipped with a door that
- complies with Section 3.1.3 Doors;
- is capable of being locked from the inside with one hand and being released from the outside in case of emergency by authorized personnel;
- has graspable latch operating and locking mechanisms located not less than 900 mm (35 in.) and not more than 1000 mm (39-3/8 in.) above the floor; and
- where the door is out-swinging, has a minimum 140 mm (5-1/2 in.) long D-shaped handle mounted either horizontally or vertically on the inside, located 100 mm (4 in.) from the hinge edge of the door and 900 mm (35-1/2 in.) from the floor and/or a spring type or gravity hinge closer.
- be provided with a lavatory conforming to Section 3.3.4 Lavatories;
- be equipped with a toilet conforming to Section 3.3.3 Toilets, and be located;
  - so that its centre line is not less than 460 mm (18-1/8 in.) and not more than 480 mm (18-7/8 in.)

3.3.7 Universal Toilet Rooms (continued)

- from an adjacent wall on one side; and
- so that its centre line is not less than 1060 mm (42 in.) to any wall, fixture or other obstruction on the other side;
- be equipped with grab bars conforming to Section 3.3.8 Grab Bars;
- have fixture clearances conforming to Sections 3.3.3 Toilets and 3.3.4 Lavatories;
- be designed to permit a wheelchair to back into the required *clear space* beside the toilet fixture;
- be equipped with a collapsible coat hook mounted not more than 1200 mm (47 in.) from the floor on a side wall and projecting not more than 50 mm (2 in.) from the wall; and
- a mirror and washroom accessories complying with Section 3.3.6 Washroom Accessories;
- Optional: be equipped with a fold-down grab bar at least 760 mm (30 in.) in length at the open side of the toilet, mounted 420 - 440 mm (16-1/2 - 17-3/8 in.) from the centre line of the toilet and 630 - 690 mm (24-3/4 - 27-1/8 in.) above the floor.
- where required, be equipped with an emergency call system linked to a light outside the door
- be equipped with a change bench that is;
  - at least 760 mm (30 in.) wide by 1830 (72 in.) long;

- if stationary, be located with the change surface between 450 - 500 mm (17 3/4 - 19 5/8 in.) from the finished floor;
- if height adjustable, have the highest surface not exceed 865 mm (34 in.) from the finished floor;
- incorporates an adjacent *clear space* not less than 760 mm (30 in.) by 1370 mm (54 in.);
- designed to support 2.66 kN (600 pounds);
- located on an accessible route in compliance with Section 1.1.3 Accessible Routes, Paths and Corridors;

- if of the fold-down type, shall be spring operated for ease of folding up against the wall; and
- if of the fold-down type, have no *operable portions* higher than 1200 mm (47 in.).
- see Figure 3.3.7.2 for details

In a retrofit situation in a smaller footprint public building and where it is technically not feasible to achieve the dimensions of Figure 3.3.7.2, or in an employee area where there is an individual washroom meeting the requirements of 3.3.7.2 on the same floor, at minimum the requirements of Figure 3.3.7.1 must be achieved.

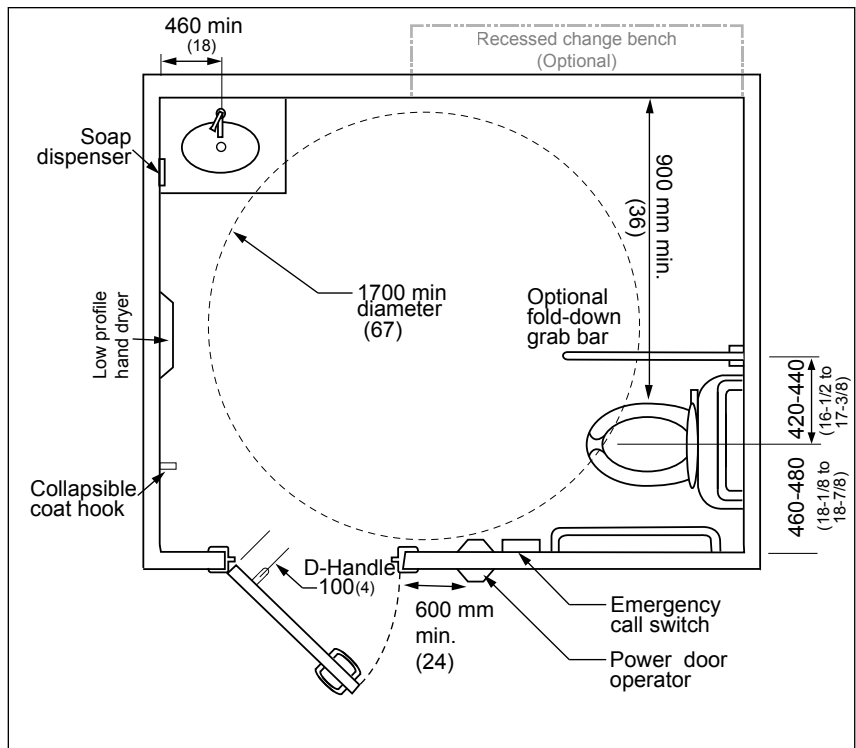

Figure 3.3.7.1 Non-Standard - Universal Toilet Room

3.3 WASHROOM FACILITIES

# INTERIOR STANDARDS

## 3.3.7 Universal Toilet Rooms (continued)

In a *retrofit* situation, where 1930 mm (76) is not technically feasible to achieve in the assembly building individual washroom (Figure 3.3.7.2), a minimum of 1700 mm (67) clear turning space is required. Least desirable, the washroom configuration may mean the use of a recessed or fold-up change bench or in rare instances, the elimination of the change bench.

### RELATED SECTIONS

- 1.1.1 Space and Reach Requirements
- 1.1.2 Protruding and Overhead Objects
- 1.2.4 Signage
- 3.1.3 Doors
- 3.2.6 Specialty Change Rooms
- 3.3.3 Toilets
- 3.3.4 Lavatories
- 3.3.5 Urinals

- 3.3.6 Washroom Accessories
- 3.3.8 Grab Bars
- 3.3.9 Shower Stalls
- 3.4.1 Visual Alarms
- 3.5.1 Controls and Operating Mechanisms
- 3.5.2 Card Access, Safety and Security Systems
- 3.5.4 Interior Glare and Light Sources
- 3.5.3 Interior Lighting

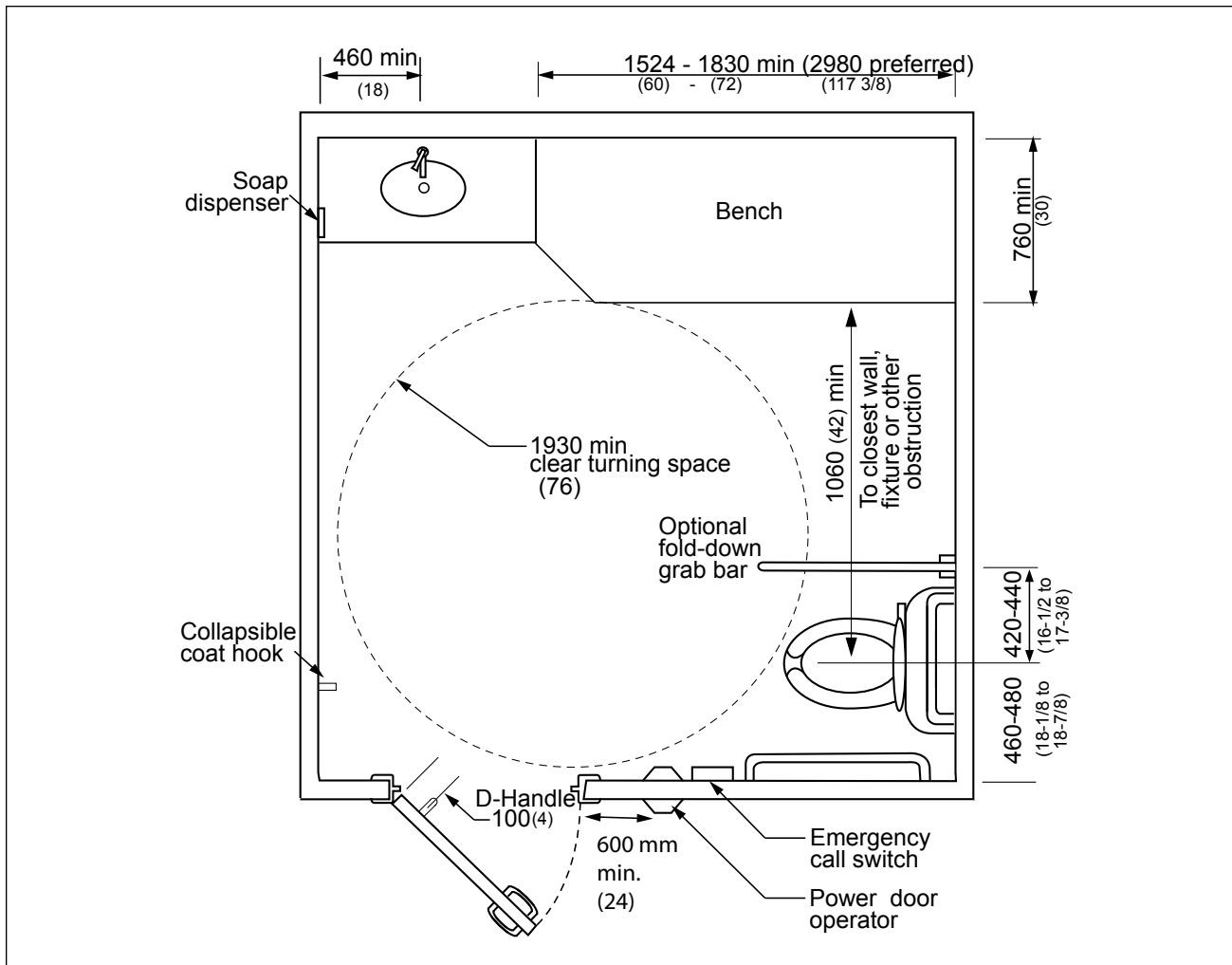

Figure 3.3.7.2 Standard - Universal Toilet Room

## 3.3.8 Grab Bars

### RATIONALE

Grab bars are an important feature to those who require assistance in standing up, sitting down or stability while standing. Transferring between toilet and wheelchair may be another scenario where grab bars are utilized.

### APPLICATION

Grab bars shall comply with this section.

### DESIGN REQUIREMENTS

Grab bars shall

- be installed to resist a load of at least 2.00 kN (450 lb.), applied vertically or horizontally;
- be not less than 30 mm (1-3/16 in.) and not more than 43 mm (1 5/8 in.) in diameter;
- have a clearance of 51 mm (2 in.) from the wall;
- be free of any sharp or abrasive *elements*;
- be *colour contrasted* with the surrounding environment; and
- have a slip-resistant surface.

Adjacent surfaces shall be free of any sharp or abrasive *elements*.

### RELATED SECTIONS

- 1.1.1 Space and Reach Requirements
- 1.2.1 Texture, Finishes and Colour
- 3.3.3 Toilets
- 3.3.5 Urinals
- 3.3.7 Individual Washrooms
- 3.3.9 Shower Stalls
- 3.5.3 Interior Lighting

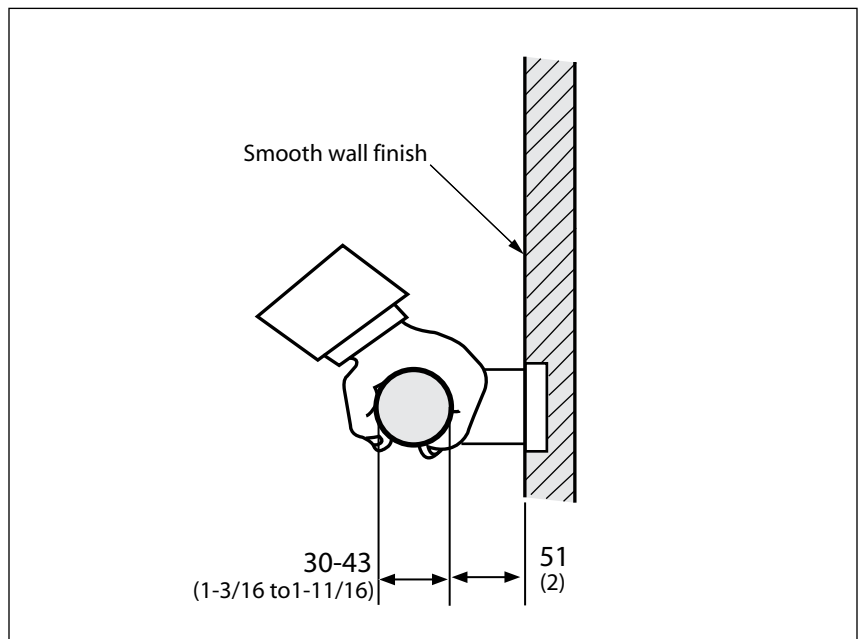

Figure 3.3.8.1 Grab Bars

# INTERIOR STANDARDS

## 3.3.9 Shower Stalls

### RATIONALE

Grab bars and nonslip materials are safety measures which will assist everyone. Commercial quality hand-held shower wands and seating benches are critical for a person who needs to sit in the shower. Equipment that *colour contrasts* from the shower stall itself assists individuals with vision *impairments*. Roll-in or curbless shower stalls eliminate the hazard of stepping over a threshold and are essential for persons with *disabilities* who use wheelchairs in the shower. At least one shower chair as an accessory piece of equipment is required for wheel-in shower users.

### APPLICATION

Where shower stalls are provided, 50% of shower stalls shall comply with this section. In a *retrofit* situation where it is *technically not feasible* to have 50% of shower stalls comply with this section, at least 10%, but never less than one, in each bathing area shall comply with this section.

### DESIGN REQUIREMENTS

*Accessible* shower stalls shall:

- be on an *accessible route* complying with Section 1.1.3 Accessible Routes, Paths and Corridors;
- be at least 1525 mm (60 in.) in width and 920 mm (36 in.) in depth;
- have a *clear space* at the

*entrance* to the shower of at least 920 mm (36 in.) in depth and the same width as the shower, except that fixtures such as a drying bench are permitted to project within the shower provided they do not restrict the width of the shower access to less than 920 mm (36");

- have a slip-resistant floor surface;
- have no threshold, or a beveled threshold not exceeding 6 mm (1/4 in.) above the finished floor;
- be equipped with a wall-mounted folding seat that is not spring-loaded, or make provisions for a portable seat that is
  - 450 mm (17-3/4 in.) wide and 400 mm (15 in.) deep;
  - mounted approximately 450 mm (17-3/4 in.) above the floor;
  - colour contrasted with the background; and
  - designed to carry a minimum load of 2.70 kN (600 lbs.);
- be equipped with an L-shaped grab bar that:
  - has a horizontal component of at least 920 mm (36 in.), mounted horizontally approximately 700 - 800 mm (27-1/2 - 31-1/2 in.) above the floor, located on the wall so at least 300 mm (11-3/4 in.) of its length is reachable from one side of the seat;
  - has a vertical component

of at least 760 mm (30 in), located at the opposite end to the seat; and

- conforms to Section 3.3.8 Grab Bars;
- be equipped with a vertical grab bar that shall:
  - be at least 760 mm (30 in.) in length;
  - be mounted 80 - 120 mm (3-1/8 - 4-3/4 in.) from the front edge, starting between 700 and 800 mm (27-1/2 and 31-1/2 in.) from the floor;
- be equipped with an individually controlable pressure equalizing or thermostatic mixing valve delivering water at a temperature no greater than 49 degree Celsius (120 degree Fahrenheit);
- have the shower control/mixing valve located above the grab bar but no higher than 1000 mm (39-3/8 in.), maximum 685 mm (27 in.) from the seat wall;
- be equipped with a shower head with at least 1525 mm (60 in.) of flexible hose that can be used both as a fixed position shower head and as a hand held shower head. The shower spray unit shall be reachable from the seated positions and have an on/off control.
- EXCEPTION: The use of two fixed height shower heads with the capability of adjusting the direction of water flow is permitted instead of a hand-held spray unit in *facilities* that may be

## 3.3 WASHROOM FACILITIES

**3.3.9 Shower Stalls (continued)**

subject to vandalism. The height of the higher shower head to be 1825 mm (72 in.). The height of the lower shower head to be 1400 mm (55-1/8 in.). A valve to direct water between the shower heads, in compliance with 3.5.1, to be located adjacent to the shower control/mixing valve; and

- have soap holder(s) which can be reached from the

seated position, ideally fully recessed.

Where the shower head is mounted on a vertical bar, the bar shall be installed so as not to obstruct the use of the grab bar. Floor drains to be level with the finished floor, located below the seat, off to one side or off to one end.

Enclosures for shower stalls shall

not obstruct controls or obstruct transfer from wheelchairs onto shower seats

**RELATED SECTIONS**

- 1.2.1 Texture, Finishes and Colour
- 3.2.6 Specialty Change Rooms
- 3.3.8 Grab Bars
- 3.5.1 Controls and Operating Mechanisms
- 3.5.3 Interior Lighting

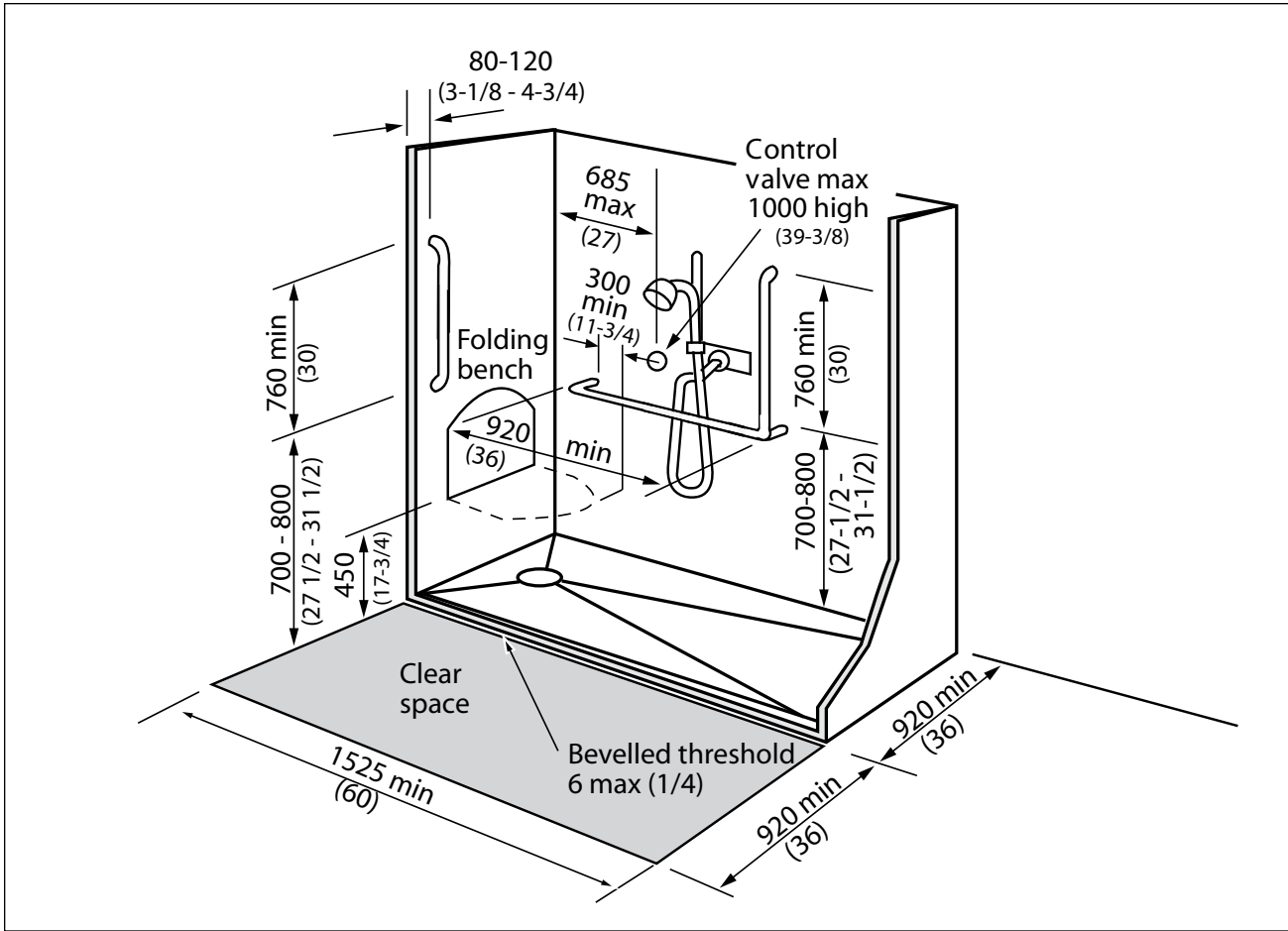

**Figure 3.3.9.1** Shower Stall

**3.3 WASHROOM FACILITIES**

# INTERIOR STANDARDS

## 3.4.1 Visual Alarms

### RATIONALE

Visual alarms are essential safety features for individuals who are deaf, deafened or hard of hearing such that they would not hear an audible alarm.

### APPLICATION

Visual alarms shall comply with this section.

At a minimum, visual alarm appliances shall be provided in *facilities* in each of the following areas: rest rooms and any other general usage areas (e.g., *meeting rooms*), hallways, lobbies and any other areas for *common use*.

Visual alarm signal appliances shall be integrated into the *facility* alarm system. If single-station audible alarms are provided, then single-station visual alarms shall be provided.

In a *retrofit* situation where an alarm system is being upgraded, the alarm system shall include visual alarm signals.

### DESIGN REQUIREMENTS

Visual alarm signals shall have the following minimum photometric and location features:

- the lamp shall be a Xenon strobe type or equivalent;
- the colour shall be *clear* or nominal white (i.e. unfiltered or *clear* filtered white light);
- the maximum pulse duration shall be two-tenths of one

second (0.2 sec) with a maximum duty cycle of 40 percent. The pulse duration is defined as the time interval between initial and final points of 10% of maximum signal;

- the intensity shall be a minimum of 75 candela;
- the flash rate shall be a minimum of 1 Hz and a maximum of 3 Hz;
- the appliance shall be placed 2100 mm (82-3/4 in.) above the highest floor level within the *space* or 150 mm (5-7/8 in.) below the ceiling, whichever is lower;
- in general, no place in any room or *space* required to have a visual signal appliance, shall be more than 15 meters (50 ft.) from the signal (in the horizontal plane). In large rooms and *spaces* exceeding 30 meters (100 ft.) across, without obstructions 2000 mm (78-3/4 in.) above the finished floor, such as auditoriums, devices may be placed around the perimeter, spaced a maximum of 30 meters (100 ft.) apart, in lieu of suspending appliances from the ceiling;
- no place in common corridors or hallways in which visual alarm signalling appliances are required shall be more than 15 meters (50 ft.) from the signal; and
- the alarms shall be synchronized to strobe in unison.

### RELATED SECTIONS

- 3.1.8 Emergency Exits, Fire Evacuation and Areas of Rescue Assistance



## 3.4.2 Assistive Listening Systems

### RATIONALE

The provision of *assistive listening devices* is important for the range of individuals who may have difficulty hearing.

Adequate and controllable lighting is required for persons who lip-read, or those who require increased task lighting, due to vision *impairment*.

### APPLICATION

*Assistive listening systems* shall comply with this section.

*Assembly areas* greater than 100 sq.m. (1080 sq.ft.) in area, where audible communications are integral to the use of the *space* (e.g., concert theatres, *meeting rooms*, classrooms, auditoria, etc.), shall be equipped with an assistive listening system encompassing the entire area. Exception: Only half the seating area need be encompassed if an induction loop system is used.

For other *assembly areas*, a permanently installed listening system shall be provided. In a smaller meeting spaces, supplementary wiring and electrical outlets necessary to support a portable listening system shall be provided. A portable listening device must be made available upon request.

The minimum number of receivers to be provided shall be equal to 4% of the total number of seats, but no less than two.

### DESIGN REQUIREMENTS

*Signage* complying with applicable provisions of Section 1.2.4 Signage and shall be installed to notify patrons of the availability of a listening system.

Induction loops, infrared systems and FM radio frequency systems shall be considered acceptable types of *assistive listening systems* for persons who are hard of hearing.

Where an induction loop system is installed, dimmer switches and other controls that incorporate transformer coils shall be located so as not to interfere with the audio induction loop.

Where infrared *assistive listening devices* are used, overhead lights shall be located so as not to cancel out the infrared signal at the receiver.

Where an FM loop system or other *assistive listening devices* are available in public *facilities* or meeting areas, portable headsets that are compatible with personal hearing aids shall be made available.

Where an induction loop system is utilized, at least half the seating area shall be encompassed.

Where the listening system provided serves individual fixed seats, such seats shall be located within a 15-meter (50-ft.) viewing distance of the stage or playing area and shall have a complete

view of the stage or playing area.

Background noise from mechanical systems shall be minimized.

Areas used for presentations and other public events, where listening to verbal communication is integral to the function of the *space*, shall incorporate one well-illuminated area for sign-language interpreting. Lighting control systems must allow the area to be independently controlled.

### RELATED SECTIONS

- 1.2.2 Acoustics
- 1.2.4 Signage
- 3.5.3 Interior Lighting

## 3.5.1 Controls and Operating Mechanisms

### RATIONALE

Operating mechanisms that require a high degree of dexterity or strength will be difficult for many people to use. They can also be obstacles for children, individuals with arthritis or even someone wearing gloves. Controls that require two hands to operate can also be difficult for some people, particularly those with reach or balance limitations, or those who must use their hands to hold canes or crutches.

The placement of controls is integral to their accessibility. For the individual using a wheelchair, the height of the controls and the *space* to position the wheelchair in front of the controls are important. Controls placed high on a wall are also difficult for children or persons of short stature.

Individuals with vision *impairments* may have difficulty with flush-mounted buttons, touch screens or controls without *tactile* markings. Controls that contrast in colour from their background, including *colour contrasted* raised letters, may be easier to locate. Persons with cognitive challenges may find counter-intuitive controls or graphics difficult.

### APPLICATION

Controls and operating mechanisms generally used by staff or public (e.g., light switches and dispenser controls) shall comply with this section. Exception: Restricted-access controls.

### DESIGN REQUIREMENTS

A *clear*, level floor area at least 900 mm x 1500 mm (35-1/2 in. x 59 in.) shall be provided at controls and operating mechanisms, such as dispensers and receptacles.

The *operable portions* of controls and operating mechanisms such as electrical switches, thermostats and intercom switches, shall be located between 900 mm (35 in.) and 1200 mm (47 in.) from the floor. Exception: Elevators and power door operator controls. Refer to Sections 3.1.3 Doors and 3.1.5 Elevators.

Controls or operating mechanisms shall:

- be located no closer than 700 mm (27-1/2 in.) from an inside corner, for side-access;
- be located no closer than 400 mm (15-3/4 in.) from an inside corner, for front-access.

Electrical outlets and other types of devices shall be located no lower than 400 mm (15-3/4 in.)

Faucets and other controls shall be hand-operated or electronically controlled.

Hand-operated controls and mechanisms shall be operable:

- with one hand, without tight grasping, pinching, or twisting of the wrist; and
- with a force of less than 13N (3 lbf.).

- Control settings shall provide *tactile* and/or auditory information, indicating function and position of controls.

Information on visual displays shall:

- be supplemented by *tactile* and/or auditory information;
- be *colour contrasted*; and
- be located on a glare-free surface.

Operating mechanisms shall be capable of being illuminated to at least a level of 100 lux (9.2 ft-candles).

*Colour contrast* shall be incorporated into controls and operating mechanisms to differentiate them from the surrounding environment.

Dispensers with visual markings shall also incorporate *tactile* lettering and pictograms.

### RELATED SECTIONS

All relevant parts of Sections 1.0 General Design Standards, 2.0 Exterior Design Standards and 3.0 Interior Design Standards.

3.5.1 Controls and Operating Mechanisms (continued)

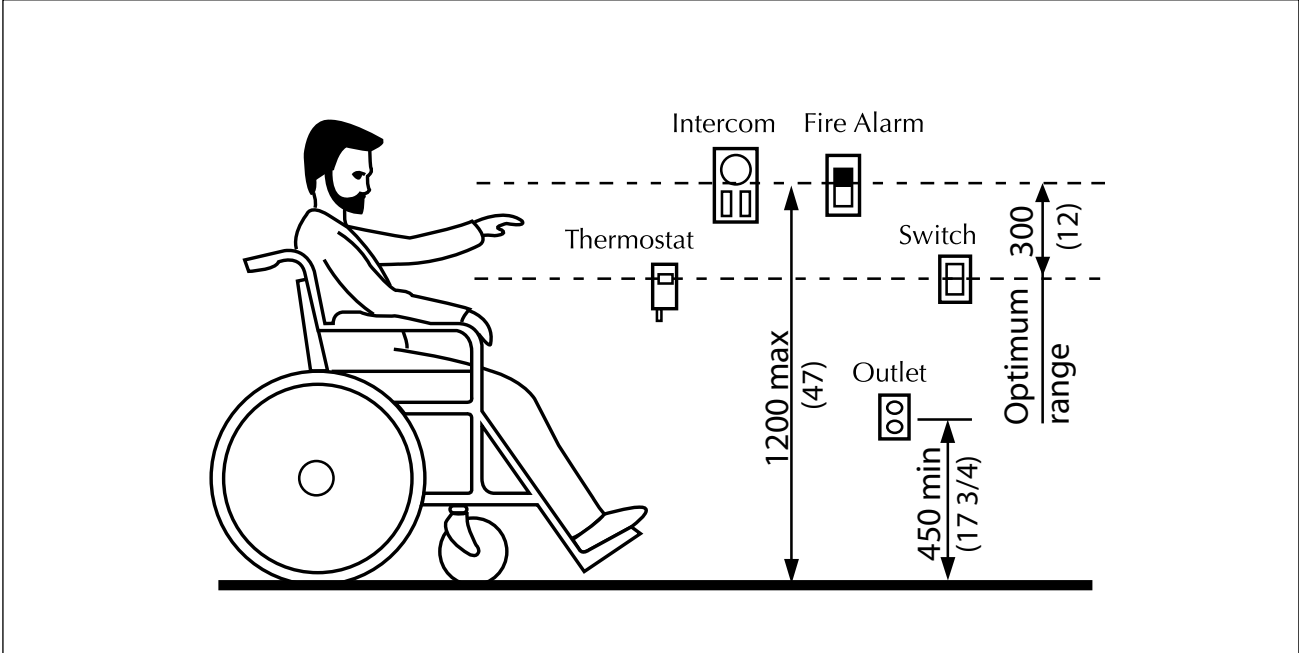

Figure 3.5.1.1 Reach Range for Accessible Controls

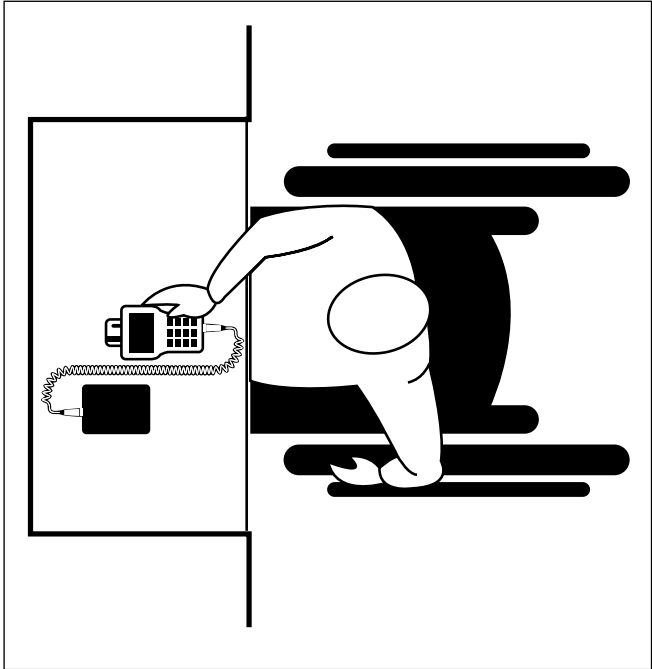

Figure 3.5.1.2 Point of sale positioning with flexable cord

3.5 INTERIOR SYSTEMS AND CONTROLS

## 3.5.2 Card Access, Safety and Security Systems

### RATIONALE

In many cases, persons such as seniors and persons with *disabilities* may be considered to have a higher degree of vulnerability and therefore seek more reassurance and inherent security. Items such as adequate lighting and *accessible* signalling devices promote this security. Emergency signalling devices are important in individual washrooms where the potential for a fall is increased and an individual may be alone.

Where card-access systems are selected as a means of entry to particular *facilities* or *spaces*, the systems and components selected should be suitable for use by persons with varying abilities, including persons with reduced manual dexterity, poor vision or difficulty with reaching. The use of heat-sensing activation buttons should be avoided, as they are indiscernible to a person who is blind. Proximity scanning card systems are preferred.

### APPLICATION

Card-access, safety, security and entry systems shall comply with this section.

### DESIGN REQUIREMENTS

Adequate lighting shall be provided continuously along public walkways, steps and *ramps* that are actively used at all times of year and/or where staff and public parking is provided.

Card access, safety and security systems shall be on an *accessible route* complying with Section 1.1.3 Accessible Routes, Paths and Corridors.

Card-entry systems shall:

- be wall-mounted, 800 mm - 900 mm (31-1/2 in. - 35-1/2 in.) above the floor or ground, adjacent to the door and free of the door swing;
- be located no closer than 700 mm (27-1/2 in.) from an inside corner, for side-access to the card-entry system;
- be located no closer than 400 mm (15-3/4 in.) from an inside corner, for front-access to the card-entry system;
- be *colour contrasted* from the surface on which they are mounted;
- provide both audible (beep) and/or verbal prompt (welcome) and visual (light) signals to indicate that access has been granted;
- where a card entry system is used that incorporates a card-slot, the card-slot shall have bevelled edges;
- be illuminated or *colour contrasted* from the mounting plate;
- include *tactile* graphic symbols on the surrounding surface that represents the card and its orientation for insertion; and
- use cards that incorporate a distinctive colour, texture or raised graphic/lettering on one side.

Intercom entry systems shall:

- comply with Section 3.5.1 Controls and Operating Mechanisms;
- provide both visual and verbal features to provide access for persons with vision, hearing or speech *impairments*; and
- provide both audible (beep) and visual (light) signals to indicate that access has been granted.

### RELATED SECTIONS

- 1.1.1 Space and Reach Requirements
- 1.1.3 Accessible Routes, Paths and Corridors
- 1.2.1 Texture, Finishes and Colour
- 2.1.2 Exterior Lighting
- 2.1.3 Streetscape
- 3.1.2 Entrances
- 3.1.3 Doors
- 3.1.5 Elevators
- 3.1.6 Platform Lifts
- 3.2.3 Offices, Work Areas and Meeting Rooms
- 3.3.7 Individual Washrooms
- 3.5.1 Controls and Operating Mechanisms
- 3.5.3 Interior Lighting

### 3.5.3 Interior Lighting

#### RATIONALE

Artificial lighting and natural light sources should provide comfortable, evenly distributed light at all working areas, in all circulation routes and in all areas of potential hazard.

#### APPLICATION

Interior lighting systems shall comply with this section.

#### DESIGN REQUIREMENTS

Light sources and fixtures shall be selected to minimize direct glare or indirect glare on nearby reflective surfaces.

Light sources shall provide as full a spectrum of light as possible, as an aid to edge and colour definition.

Lighting shall be configured to create an even distribution at floor level and to minimize pools of light and areas of shadow.

The leading edge of stairs, steps, *ramps* or escalators shall be evenly lighted to minimize tripping hazards.

Lighting levels in elevator lobbies shall be similar to the lighting levels in elevator cabs, to minimize tripping hazards, and in no case shall be less than 200 lux (20 ft-candles).

Lighting levels in washrooms and dressing rooms shall be evenly distributed and no less than 200 lux (20 ft-candles).

Lighting levels in office areas shall be evenly distributed and no less than 300 lux (30 ft-candles).

Emergency lighting over stairs and *ramps*, in an exit or path of travel, shall be at least 10 lux (1 ft-candle).

Lighting over directional or informational *signage*, or highlighting other orientation features at information or service counters, and card or keypad security systems, shall be no less than 200 lux (20 ft-candles) at the working surface.

Lighting in *meeting rooms* and *assembly areas* shall be evenly distributed, and shall be capable of being adjusted (e.g., dimmers).

Lighting at lecterns, podiums/platforms or other speaker locations shall be capable of being enhanced, even when other lighting is dimmed, to permit ease of lip-reading and/or viewing of the hand actions of a nearby signer for persons who are deaf.

#### RELATED SECTIONS

All relevant parts of Sections 1.0 General Design Standards, 2.0 Exterior Design Standards and 3.0 Interior Design Standards.

## 3.5 INTERIOR SYSTEMS AND CONTROLS

## 3.5.4 Interior Glare and Light Sources

### RATIONALE

Direct or reflected glare off of floors, walls, work surfaces, or signs is uncomfortable for all users and a barrier to persons with reduced vision. Therefore, every attempt should be made to select light sources, materials and finishes which do not add to the problem, and to ensure that natural daylight is controllable.

The strategic use of lighting is valuable to all individuals, and especially important for individuals with some form of vision *impairment*. In addition, offering a variety of task lighting at work areas is beneficial to all.

### APPLICATION

Systems used to control glare and excessive reflected light shall comply with this section.

### DESIGN REQUIREMENTS

Monolithic floor surfaces, such as stone, granite, marble or terrazzo, shall have a matte or honed finish, to minimize reflected glare. Extensive high-gloss floor finishes are not acceptable but high-gloss materials may be incorporated into floor finish details, as long as they do not result in large reflective surfaces.

Finishes such as vinyl, other composition materials, quarry tile, glazed tile or mosaics, used on horizontal surfaces, such as floors and work surfaces, shall be in matte or satin finishes.

Extensive high gloss floor finishes are not acceptable, but high-gloss materials may be incorporated into floor finish details, as long as they do not result in large reflective surfaces and/or slip hazards.

Finishes such as paint, vinyl wall coverings, stone, marble, wood, metals, plastic laminate, etc., used on vertical surfaces, such as walls and columns, shall have matte or satin finishes. Extensive high-gloss wall finishes are not acceptable, but high-gloss materials may be incorporated into wall finish details, as long as they do not result in large reflective surfaces.

Curtains, blinds or other sun-screening systems shall be provided at windows and other places where direct sunlight can adversely affect the level of lighting and/or reflected glare.

Light fixtures shall be selected with diffusers, lenses or recessed light sources, so that minimal glare is created.

If surface mounted fluorescent ceiling fixtures are mounted below 2440 mm (96 in.), they shall have darkened sides (i.e., not wrap-around lenses) and be positioned perpendicular to the dominant direction of travel, or used in valance-type lighting at the sides of the *space*, so that the lighting is indirect.

The location of special features and key orientation *elements*

shall be enhanced through the use of supplementary lighting. Such lighting shall have upward or downward components only.

### RELATED SECTIONS

- 1.1.3 Accessible Routes, Paths and Corridors
- 1.1.6 Stairs
- 3.1.1 Interior Floor Surfaces
- 3.1.2 Entrances
- 3.1.4 Windows, Glazed Screens and Sidelights
- 3.1.5 Elevators
- 3.1.6 Platform Lifts
- 3.1.7 Escalators
- 3.2.1 Information, Reception and Service Counters
- 3.3.1 Toilet Facilities
- 3.5.3 Interior Lighting

## 3.6.1 Arenas, Gymnasiums, Halls and Other Indoor Recreational Facilities

### RATIONALE

Opportunities for recreation, leisure and active sport participation should be available to all members of the community. Access should be provided to halls, arenas, and other sports *facilities*, including access to the *site*, all activity *spaces*, gymnasias, fitness *facilities*, lockers, change rooms and showers. Active participants, spectators, volunteers and members of staff could include persons with various ability levels.

### APPLICATION

Arenas, halls and other indoor recreation *facilities* shall comply with this section.

Where dressing *facilities* are provided for use by the general public, clients, customers, performers or staff, at least 50%, but never less than one, for each type of use in each cluster of dressing *facilities* shall be *accessible* and in compliance with Section 3.2.6 Specialty Change Rooms. It is preferable to have all dressing *facilities accessible*.

### DESIGN REQUIREMENTS

Arenas, halls and other indoor recreation *facilities* shall include the following:

- where visitor, spectator and/or participant seating is provided, have *accessible* seating options in compliance with Section 1.3.3 Elevated

Areas and Platforms;

- an *accessible route* to the arena/*facility* floor in compliance with Section 1.1.3 Accessible Routes, Paths and Corridors;
- one accessible entrance through a public access gate which is at least 950 mm (37-1/2 in.) wide, onto the ice surface from the public area. Other gates from the penalty and players boxes may be narrower;
- where *facilities* are provided for performances and other events, they shall have a direct *accessible route* from the lobby/*entrances* and viewing locations to all performing areas, including stages, dressing rooms, washrooms and all other *spaces* used by performers in compliance with Section 1.1.3 Accessible Routes, Paths and Corridors;
- where dressing *facilities* are provided, have dressing *facilities* that comply with Section 3.2.6 Specialty Change Rooms;
- where lockers or shelving is provided they shall comply with Sections 3.2.5 Storage, Shelving and Display Units and 3.2.7 Lockers and Storage Units;
- where coat hooks are provided, have at least 10%, but never less than one, within the reach ranges specified in Section 1.1.1 Space and Reach Requirements;
- where toilets and bathing *facilities* are provided, have

toilets and bathing *facilities* that comply with Section 3.3.1 Toilet Facilities;

- where concessions or other service counters are provided, comply with Section 3.2.1 Information, Reception and Service Counters;
- where swimming pool, hot pools or therapy pools are provided, they comply with Sections 1.4.1 Swimming Pools.

### RELATED SECTIONS

All relevant parts of Sections 1.0 General Design Standards, 2.0 Exterior Design Standards and 3.0 Interior Design Standards.

# INTERIOR STANDARDS

## 3.6.2 Cafeterias

### RATIONALE

Cafeteria serving lines and seating areas need to reflect the lower sight lines, reduced reach, knee-space and maneuvering requirements of persons using wheelchairs or scooters. Patrons using mobility devices may not be able to hold a tray or food items while supporting themselves on canes or maneuvering a wheelchair. Tray slides should be designed to move trays with a minimum of ease. Continuous tray slides with *colour contrasted* stops are preferred.

Tables with straight legs at the corners or cantilevered tables, are preferred over pedestal tables.

### APPLICATION

Cafeterias shall comply with this section.

Where fixed tables or counters are provided, at least 10%, but not less than one, shall be *accessible* and shall comply with Section 3.2.2 Tables, Counters and Work Surfaces. It is preferable to have all fixed tables *accessible*.

In new construction, and where practicable in *alterations*, the fixed tables (or counters) shall be distributed throughout the *space of facility*.

At least one lane at each cashier area shall be *accessible* and comply with this section. It is preferable to have all lanes at all cashier areas *accessible*.

### DESIGN REQUIREMENTS

Where food or drink is served at counters exceeding 865 mm (34 in.) in height for use by customers seated on stools or standing at the counter, a portion of the main counter which is 1525 mm (60 in.) in length (minimum) shall be provided in compliance with Section 3.2.1 Information, Reception and Service Counters, or service shall be available at *accessible* tables within the same area.

All *accessible* fixed tables shall be *accessible* by means of an *access aisle* at least 1100 mm (43-1/4 in.) *clear* between parallel edges of tables or between a wall and the table edges.

Dining areas, including raised or sunken dining areas, and outdoor seating areas shall be *accessible*. In a *retrofit* situation where it is *technically not feasible* to provide access to all levels within a dining area, or to all parts of outdoor seating areas, at least one dining area shall be *accessible*. The *accessible* area must feature the same level of service and *décor* as the rest of the dining area and it must not be restricted to use by people with *disabilities*.

Food service lines shall have a minimum *clear* width of 1100 mm (43-1/4 in.).

Tray slides shall be mounted no higher than 865 mm (34 in.).

If self-service shelves are provided, at least 50% must be within the reach ranges specified

in Section 1.1.1 Space and Reach Requirements. It is preferable to have all self-service shelves *accessible*.

Self-service shelves and dispensing devices for tableware, dishware, condiments, food and beverages shall be installed to comply with Section 1.1.1 Space and Reach Requirements.

Food behind glass doors shall have large print and Braille labels on the door.

Where menus are posted on a wall near the *entrance*, they shall be centered 1500 mm (60) from the floor and comply with the CNIB Clear Print Guidelines.

In banquet rooms or *spaces* where a head table or speaker's lectern is located on a raised platform, the platform shall be *accessible* in compliance with Sections 1.1.5 Ramps or 1.3.3 Elevated Areas and Platforms, as well as 3.1.6 Platform Lifts.

*Spaces* for vending machines, beverage dispensers and other equipment shall comply with Section 1.1.1 Space and Reach Requirements and shall be located on an *accessible route* in compliance with Section 1.1.3 Accessible Routes, Paths and Corridors.

Cashier locations should feature at least one *access aisle*, which is a minimum of 1100 mm (43-1/4 in.) wide. It is preferable to have all aisles *accessible*.

## 3.6 INTERIOR CONTEXT SPECIFIC REQUIREMENTS



**3.6.2 Cafeterias (continued)**

*Barriers* and/or turnstiles, where provided to control access, shall comply with Section 1.1.4 Gates, Turnstiles and Openings.

Queuing areas shall comply with Section 1.3.5 Waiting and Queuing Areas.

Access to outdoor eating areas shall comply with Section 2.2.1 Balconies, Plazas and Patios.

**RELATED SECTIONS**

All relevant parts of Sections 1.0 General Design Standards, 2.0 Exterior Design Standards and 3.0 Interior Design Standards.

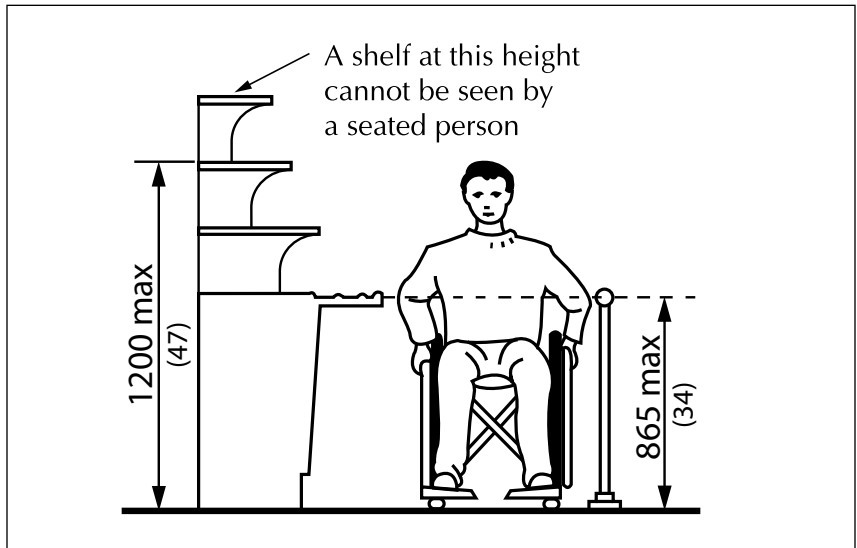

**Figure 3.6.2.1** Shelf Heights

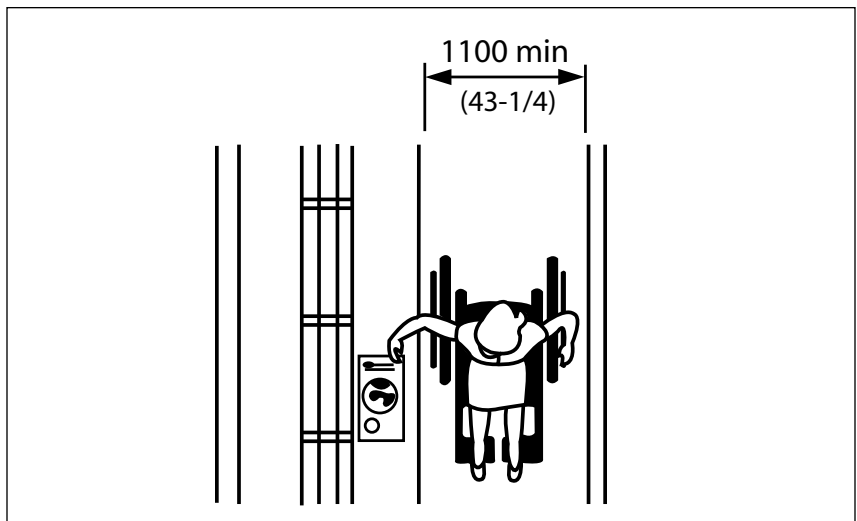

**Figure 3.6.2.2** Aisle Width

**3.6 INTERIOR CONTEXT SPECIFIC REQUIREMENTS**

## 3.6.3 Libraries

### RATIONALE

Traditional and automated systems should be available to all patrons and staff. Both the design of the *facility* and the provision of services should be considered. Service counters and study tables should accommodate the knee-space and armrest requirements of persons using wheelchairs. On-Line catalogues, tables and workstations should be provided at a range of heights, to accommodate persons who are standing or sitting, as well as children of many ages and sizes.

The provision of workstations equipped with assistive technology such as large displays, screen readers, etc. will increase the accessibility of a library.

### APPLICATION

Libraries shall comply with this section.

Where fixed seating or study tables are provided, at least 10% but no less than one shall be *accessible* and in compliance with this section. It is preferable to have all fixed seating, tables and study tables *accessible*.

At least one location at each checkout area shall be *accessible* and comply with this section. It is preferable to have all locations at checkout areas *accessible*.

Where computer workstations are provided, at least 10% but no less than one shall be *accessible* and

shall comply with this section. It is preferable to have all computer workstations *accessible*.

### DESIGN REQUIREMENTS

*Accessible* fixed seating, tables and study tables shall be located on an *accessible route* in compliance with Section 1.1.3 Accessible Routes, Paths and Corridors.

Clearances between fixed seating, tables and study tables shall comply with Section 1.1.3 Accessible Routes, Paths and Corridors.

Where shelving is provided at fixed seating, tables or study tables, the shelving shall be no higher than 1370 mm (54 in.) from the floor to the bottom of the highest shelf (Section 1.1.1 Space and Reach Requirements).

*Accessible* fixed study tables shall incorporate:

- work surfaces and knee/toe clearance in compliance with Section 1.1.1.12 Space and Reach Requirements;
- an electrical outlet; and

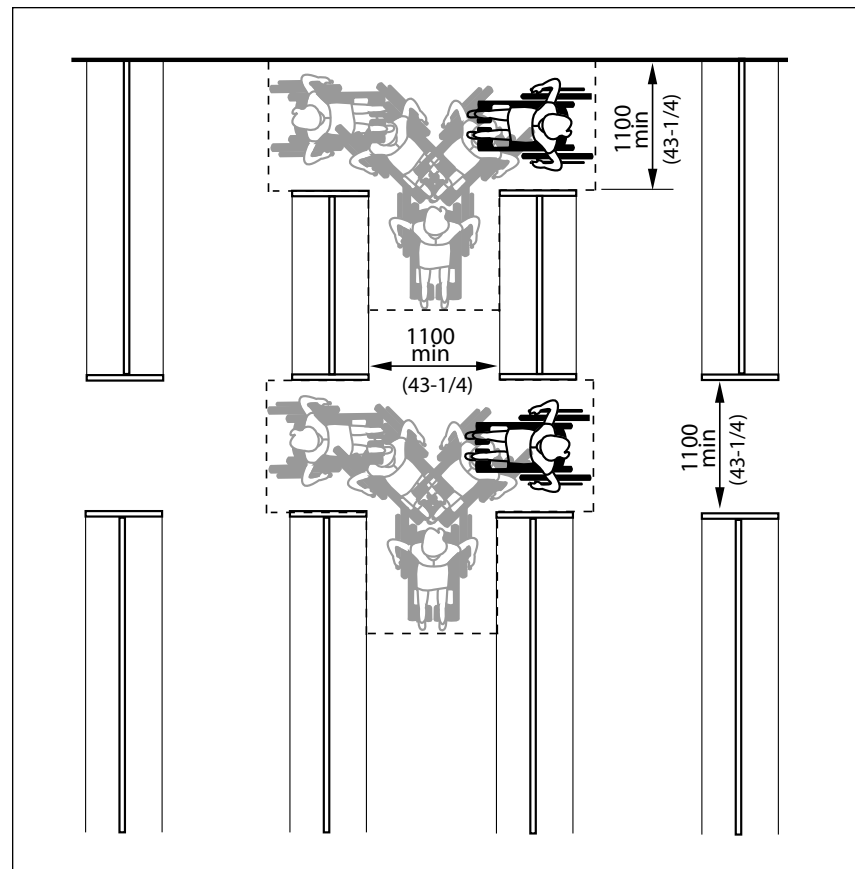

**Figure 3.6.3.1** Library Stack Aisle Width

**3.6.3 Libraries (continued)**

- general lighting levels of at least 200 lux (18.6 ft-candles) at the work surface, where possible, with task lighting capable of increasing the illumination of the work surface to at least 500 lux (50 ft-candles).

Minimum *clear aisle space* at stacks shall comply with Section 1.1.1 Space and Reach Requirements. Aisle configurations shall incorporate a *clear space* allowing a person in a wheelchair to make a 180-degree turn. See figure 1.1.1.3.

Service counters shall comply with Section 3.2.1 Information, Reception and Service Counters.

Where provided, at least one computer workstations shall incorporate:

- power height adjustment (preferred);
- knee and toe *space* below in compliance with Sections 1.1.1 Space and Reach Requirements and 3.2.2 Tables, Counters and Work Areas;
- a maximum work surface height of 865 mm (34 in.); and
- a maximum table depth of 900 mm (35 in.).

A minimum of one movable chair shall be provided at every information service counter, computer catalogue or computer workstation.

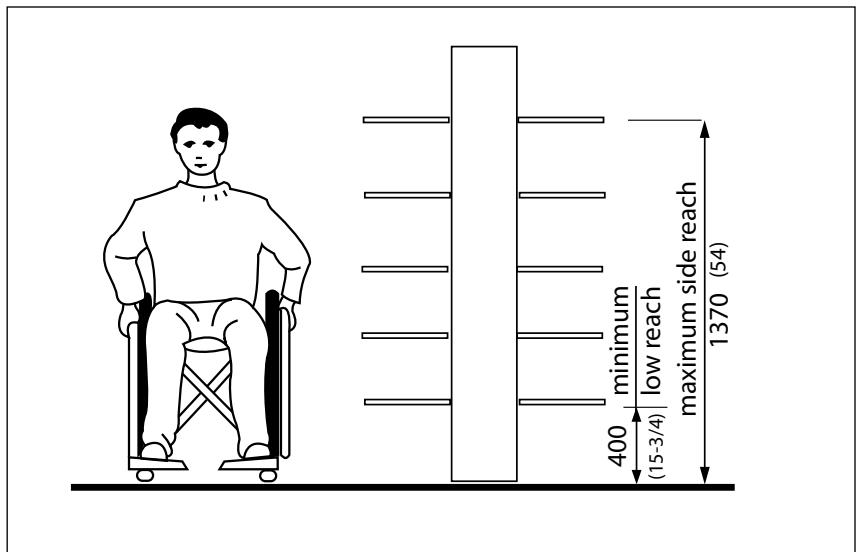

**Figure 3.6.3.2** Library Stack Reach Heights

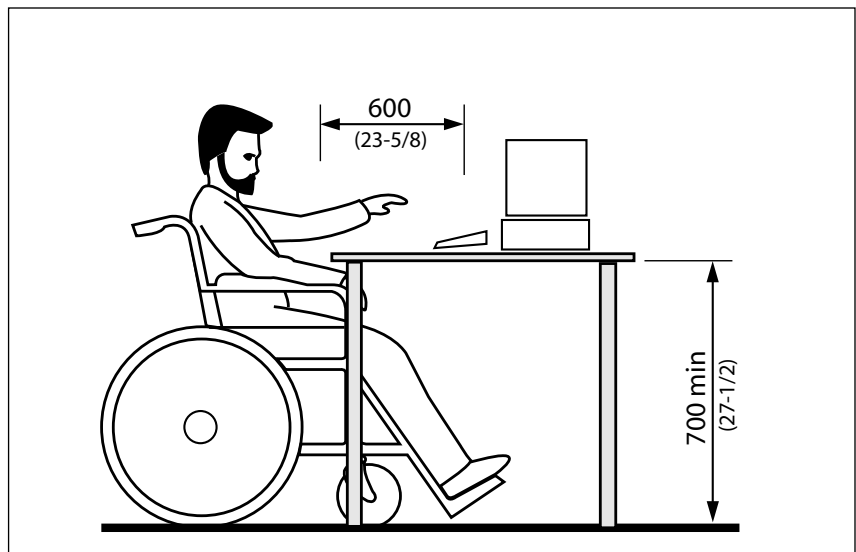

**Figure 3.6.3.3** Work Surfaces

**3.6 INTERIOR CONTEXT SPECIFIC REQUIREMENTS**

# INTERIOR STANDARDS

## 3.6.3 Libraries (continued)

Book return slots shall:

- be located on an *accessible route* complying with 1.1.3;
- be located adjacent to a 2440 by 2440 mm (96 by 96 in.) level platform. In a *retrofit* situation where it is *technically not feasible* to create a 2440 x 2440 mm (96 by 96 in.) platform, the platform may be reduced to 1525 x 1525 mm (60 by 60 in.); and
- have a slot that is operable using one hand and a closed fist, located between 860 mm (34 in.) and 900 mm (35 in.) above the floor.

Lighting at book stacks should be:

- angled to avoid shadowing;
- positioned to provide good reading light at a minimum of 300 lux/ 28 ft. candles.

The acoustic quality shall be free of unnecessary background noise and should permit comprehension by persons with limited hearing.

Where CDs DVD's, audio books, etc. are available as part of the library resource materials, or for loan purposes, a separate *space* should be provided for using this material without disturbing other library users. An acceptable alternative would be to provide headphones for use.

### RELATED SECTIONS

All relevant parts of Sections 1.0 General Design Standards, 2.0 Exterior Design Standards and 3.0 Interior Design Standards.

**3.6.4 Cashier and Workplace Accommodations**

**RATIONALE**

Work spaces should be designed with a view to future adaptation or accommodation of individual equipment or assistive devices.

**APPLICATION**

Business, mercantile and civic facilities shall comply with this section.

In areas used for transactions where counters have cash registers and are provided for sales and distribution of goods or services to the public, at least one of each type shall have a portion of the counter accessible and in compliance with this section.

Point of sale devices must be reachable by all patrons of a facility from a seated position in compliance with Figure 3.5.1.2.

All electronic ticket booths or self-serve kiosks must be usable by a range of people.

Where counters are dispersed throughout the facility, the accessible counters must also be dispersed throughout the facility.

In public facilities where counters or teller windows have solid partitions or security glazing to separate personnel from the public, at least one of each type shall provide a method to facilitate voice communication such as grills, slats, talk-through baffles, intercoms or telephone handset devices.

Accessible checkout aisles shall

be provided in conformance with Table 3.6.4.1.

**DESIGN REQUIREMENTS**

All accessible sales and service counters shall be on an accessible route that complies with Section 1.1.3 Accessible Routes, Paths and Corridors.

In areas used for transactions where counters have cash registers and are provided for sales and distribution of goods or services to the public, the counter shall have provision for a transaction counter that is at least 920 mm (36 in.) in length, with a maximum height of 865 mm (34 in.) above the finished floor.

Areas used for transactions that may not have a cash register but at which goods and services are sold, including, but not limited to, ticketing counters, teller stations, registration counters, information counters, box office counters and library check-out areas, shall comply with Section 3.2.1 Information, Reception and Service Counters.

Where counters or teller windows have solid partitions or security glazing to separate personnel from the public, the method of communication provided shall be accessible to both individuals

who use wheelchairs and individuals who have difficulty bending.

The clear width of accessible checkout lines shall comply with 1.1.3, and the maximum adjoining counter height shall not exceed 965 mm (38 in.) above the finished floor. The top of the lip shall not exceed 1015 mm (40 in.) above the finished floor.

Point of sale devices shall not be affixed to a counter, rather they shall be either wireless or attached with a coil cord long enough to reach within 600 mm (23 5/8 in.) of a service counter see Figure 3.5.1.2.

Signage identifying accessible checkout aisles shall incorporate the international symbol of access and shall be mounted above the checkout aisle in the same location where the checkout number or type of checkout is displayed.

Retail spaces shall:

- have access aisles at least 1200 mm (47 in.) wide; and
- no retail items located above 1370 mm (54 in.).

**RELATED SECTIONS**

All relevant parts of Sections 1.0 General Design Standards, 2.0 Exterior Design Standards and 3.0 Interior Design Standards.

Total checkout aisles of each design	Minimum number of accessible checkout aisles of each design
1-4	1
5-8	2
9-15	3
Over 15	3 plus 20% of additional aisles

**Table 3.6.4.1** Required Number of Accessible Check-out Aisles

**3.6 INTERIOR CONTEXT SPECIFIC REQUIREMENTS**

## 3.6.5 Emergency Services

### RATIONALE

Emergency services should accommodate persons with *disabilities*, who may be members of the public detainees, members of counsel or staff. All areas of emergency service stations that are used by the public, members of staff and counsel should be *accessible* to persons with *disabilities*. Secure areas, such as police holding cells and common areas used by detainees, should have provisions to *accommodate* persons with *disabilities*.

### APPLICATION

Except as specified in this section, all *common use areas* serving *accessible* cells or rooms and all *public use areas* shall be designed and constructed to comply with Sections 1.0 General Design Standards, 2.0 Exterior Design Standards and 3.0 Interior Design Standards.

Exceptions: Requirements for areas of rescue assistance in Section 3.1.8 Emergency Exits, Fire Evacuation and Areas of Rescue and Assistance do not apply. Compliance with requirements for elevators and stairs is not required in multi-storey housing *facilities* where *accessible* cells or rooms, all *common use areas* serving them and all *public use areas* are located on an *accessible route*.

### DESIGN REQUIREMENTS

*Entrances* used by the public, including those that are secured, shall be *accessible* to comply with Section 3.1.2 Entrances.

Exception: Secured *entrances*, doors and doorways operated only by security personnel shall not be required to have *accessible* door hardware.

Where security systems are provided at public or other *entrances* required to be *accessible* by this section, an *accessible route* complying with Section 1.1.3 Accessible Routes, Paths and Corridors shall be provided through fixed security *barriers* at required *accessible entrances*. Where security *barriers* incorporate equipment such as metal detectors, fluoroscopes, or other similar devices which cannot be made *accessible*, an *accessible route* shall be provided adjacent to such security screening devices, to facilitate an equivalent *circulation path*.

In non-contact visiting areas where detainees are separated from visitors, the following *elements*, where provided, shall be *accessible* and located on an *accessible route* complying with Section 1.1.3 Accessible Routes, Paths and Corridors.

Requirements for cubicles and counters:

- 5%, but not less than one, shall comply with Section

3.2.2 Tables, Counters and Work Surfaces on both the visitor and detainee sides;

- where counters are provided, they shall comply with Section 3.2.1 Information, Reception and Service Counters on both the visitor and detainee sides.

Exception: Non-contact visiting areas not serving *accessible* cells or rooms.

Requirements for partitions:

Solid partitions or security glazing separating visitors from detainees through which communication is necessary shall incorporate communication systems which are *accessible* to both individuals who use wheelchairs and individuals who have difficulty bending. If such communication systems incorporate a telephone handset, at least one telephone handset shall be equipped with a volume control.

At least 2%, but not less than one, of the total number of cells shall comply with this section. Where special cells are provided (e.g., orientation, protective custody, disciplinary, segregation, detoxification or medical isolation), at least one of each purpose shall comply with this section.

In addition to the aforementioned cell requirements, at least 2%, but not less than one, of general cells shall be equipped with audible emergency warning systems in compliance with this section.

## 3.6.5 Emergency Services (continued)

Within any emergency facility:

- all doors and doorways on an *accessible route* shall comply with Sections 3.1.3 Doors. Exception: Secured *entrances*, doors and doorways operated only by security personnel shall not be required to have *accessible* door hardware;
- at least one toilet and one bathing facility shall comply with Sections 3.3.1 Toilet Facilities;
- *accessible* beds shall have maneuvering *space* at least 920 mm (36 in.) wide along one side;
- at least one drinking fountain and/or water cooler shall comply with Sections 1.3.1 Drinking Fountains;
- fixed or built-in tables, counters or work surfaces shall comply with Sections 3.2.2 Tables Counters and Work Surfaces;
- at least one fixed bench shall comply with Sections 1.3.6 Seating;
- fixed or built-in storage shall comply with Sections 3.2.5 Storage, Shelving, and Display Units;
- all controls intended for operation by detainees shall comply with Sections 3.5.1 Controls and Operating Mechanisms.

alarms are not required where detainees are not allowed independent means of *egress*.

Where permanently installed telephones are provided within cells, they shall have volume controls.

### RELATED SECTIONS

All relevant parts of Sections 1.0 General Design Standards, 2.0 Exterior Design Standards and 3.0 Interior Design Standards.

Medical care facilities providing physical or medical treatment or care shall be *accessible* to persons with *disabilities*.

Where audible emergency warning systems are provided to serve occupants of cells, visual alarms complying with Sections 3.4.1 Visual Alarms shall also be provided. Exception: Visual

## 3.6 INTERIOR CONTEXT SPECIFIC REQUIREMENTS

## 3.6.5 Public Housing

### RATIONALE

Persons with *disabilities* should have equitable access to housing choices. They should also have the opportunity to visit family, neighbours and friends within their homes.

*Accessible* housing will incorporate features throughout the house to accommodate a family member who uses a wheelchair, scooter or other type of mobility aid.

*Visitable* housing will incorporate basic access features to accommodate visitors with *disabilities*, elderly persons or residents who may be temporarily *disabled*. Basic access includes the ability to enter safely, maneuver throughout the *entrance*-level of the house, and *space* to access a toilet.

### APPLICATION

All public housing units shall be *visitable* and shall comply with this section.

10% of all public housing units shall be *accessible* and shall comply with this section.

The *common-use* areas of public housing *facilities* shall comply with all relevant sections of this manual.

### DESIGN REQUIREMENTS

*Visitable* public housing units shall comply with the 'Visitable

Dwelling Units' section of CAN/CSA B651: Accessible design for the built environment (most current version).

*Accessible* public housing units shall comply with the most current version of the 'Accessible Dwelling Units' section of CAN/CSA B651: Accessible Design for the Built Environment.

### RELATED SECTIONS

All relevant parts of Sections 1.0 General Design Standards, 2.0 Exterior Design Standards and 3.0 Interior Design Standards.



## 3.6.6 Training Facilities

### RATIONALE

Students, teachers and staff with *disabilities* should have equitable access to school facilities.

This section of the manual identifies general accessibility requirements that are applicable to all areas of training facilities.

Students teachers and staff with *disabilities* should be accommodated in all classrooms and other learning *spaces* throughout a school. Basic accommodation includes the ability to enter and move freely throughout the *space*, as well as use the various built-in *elements* within (i.e. blackboards, switches, computer stations, sinks, etc). Individual students with a *disability* may require additional accommodations beyond those identified within this section.

Where built-in *elements* are duplicated within an individual classroom/learning *space*, such as laboratory benches or pinboards, at least one of each type of *element* should be *accessible* to students, teachers and staff with *disabilities*.

Wherever possible, fixtures, fittings, furniture and equipment should be specified for classrooms and other learning *spaces*, which is usable by students, teachers and staff with *disabilities*. However, it is recognized that not all equipment found in classrooms and other learning *spaces* is usable by persons

with *disabilities* - such as heavy machinery found in trades and technology classrooms.

### APPLICATION

All classrooms and other learning *spaces* shall be *accessible* and shall comply with this section. Where built-in *elements* such as fixed seating, tables or laboratory benches are provided within a classroom/learning *space*, at least 10% but no less than one, shall be *accessible* and in compliance with this section.

At least 50% of shelf *space* in storage facilities in classroom/learning *spaces* shall comply with this section.

Classroom 'portables' shall comply with this section.

The *common-use* areas of school *facilities* shall comply with all relevant sections of this manual.

### DESIGN REQUIREMENTS

Classrooms and other training *spaces* shall incorporate:

- at least one entry/*egress* door in compliance with Sections 3.1.3 Entrances;
- floor surfaces throughout in compliance with Sections 3.1.1 Interior Floor Surfaces;
- primary circulation routes in compliance with Sections 1.1.1 Space and Reach Requirements, linking all functional areas and *elements* within the *space*;

- secondary circulation routes no less than 920 mm (36 in.) wide;
- controls and operating mechanisms in compliance with Sections 3.5.1 Controls and Operating Mechanisms; and
- windows, glazed screens and sidelights in compliance with Section 3.1.4 Windows, Glazed Screens and Sidelights.

Classrooms, auditoriums, *assembly areas* and other training *spaces* that incorporate fixed seating shall:

- incorporate *accessible* seating in compliance with Section 1.3.3 Elevated Areas and Platforms; and
- where applicable, incorporate assistive listening systems in compliance with Section 3.4.2 Assistive Listening Systems.

Where classrooms or other training *spaces* incorporate safety equipment such as fire extinguishers, eye-baths or deluge showers, such equipment shall be *accessible* to and usable by persons with *disabilities*.

*Accessible* work surfaces and other built-in *elements* within classrooms and other training *spaces* shall:

- comply with Section 3.2.2 Tables, Counters and Work Surfaces;
- where applicable, incorporate controls and operating mechanisms in compliance with

# INTERIOR STANDARDS

## 3.6.6 Training Facilities

- Section 3.5.1 Controls and Operating Mechanisms; and
- be large enough to accommodate an assistant and extra equipment.

*Accessible storage elements* within classrooms and other training spaces shall:

- be located on an *accessible route* with adjacent *clear space* in compliance with Section 1.1.1 Space and Reach Requirements;
- comply with at least one of the reach ranges specified in Section 1.1.1 Space and Reach Requirements; and
- incorporate *operable portions* that comply with Section 3.5.1 Controls and Operating Mechanisms.

Where pin boards, blackboards, or other display systems are provided within classrooms and other training spaces, at least one of each type shall:

- be located on an *accessible route* with adjacent *clear space* in compliance with Section 1.1.1 Space and Reach Requirements; and
- have its lowest edge located no higher than 760 mm (30 in.).

Where classrooms or other training spaces incorporate demonstration areas such as laboratory benches, fume cabinets or computer stations, provisions must be made to facilitate viewing from a variety of eye-levels. The installation of mirrors over the demon-

stration areas is one way to provide such access.

Classrooms and other spaces intended for general teaching and study shall feature a background noise level no higher than 30 dB(A).

Lockers shall comply with Section 3.2.7 Lockers and Storage Units.

Where classrooms and other training spaces incorporate sinks, at least one shall:

- be located on an *accessible route* with adjacent *clear space*;
- where a forward approach is provided, incorporate knee space below at least 760 mm (30 in.) wide, 480 mm (18-7/8 in.) deep, and 685 mm (27 in.) high;
- have the height of the rim or the counter top (whichever is higher) 710 mm - 856 mm (28 in. - 34 in.);
- incorporate faucets and other controls in compliance with Section 3.5.1 Controls and Operating Mechanisms;
- have water supply and drain pipes under the sink insulated or otherwise configured to protect against contact; and
- incorporate no sharp or abrasive surfaces under the sink.

Where classrooms and other training spaces incorporate kitchens, each kitchen shall:

- if of a pass-through configuration, have two entries and where counters, appliances

or cabinets are on two opposing sides, or when counters, appliances or cabinets are opposite a parallel wall, clearance between all opposing base cabinets, counter tops, appliances, or walls within a kitchen work area shall be 1100 mm (43-1/4 in.) minimum;

- if of a U-shaped configuration enclosed on three contiguous sides, have a minimum clearance of 2440 mm (96 in.) between all opposing base cabinets, counter tops, appliances, or walls within kitchen work areas. In a *retrofit* situation where providing a 2440 mm (96 in.) space is technically not feasible, the space between opposing base cabinets, counter tops, appliances, or walls within kitchen work areas may be reduced to 2130 mm (84 in.);
- incorporate at least one work surface minimum 920 mm (36 in.) wide, located maximum 865 mm (34 in.) high, with knee space below at least 760 mm (30 in.) wide, 480 mm (18-7/8 in.) deep, and 685 mm (27 in.) high; and
- incorporate *elements* that feature *colour contrast* to visually differentiate the cabinets and appliances from adjacent wall and floor surfaces, the countertop from the cabinets and adjacent walls, and operable hardware on cabinets.

Work surfaces shall incorporate non-glare finishes.

## 3.6 INTERIOR CONTEXT SPECIFIC REQUIREMENTS

### 3.6.6 Training Facilities

Where classrooms and other training spaces incorporate appliances, at least one of each type of appliance shall:

- be located on an *accessible route* with adjacent *clear space* in compliance with Section 1.1.1 Space and reach Requirements; and
- incorporate controls and *operable portions* that comply with Section 3.5.1 Controls and Operating Mechanisms. Exceptions: Appliance doors and door latching devices.

Where classrooms and other training spaces incorporate dishwashers, the dishwashers shall incorporate *clear space* adjacent to the dishwasher door. The dishwasher door, in the open position, shall not obstruct the *clear space* for the dishwasher or the sink.

Where classrooms and other training spaces incorporate ranges and/or cooktops, they shall:

- incorporate controls that are located to avoid reaching across the burners; and
- where a forward approach is provided incorporate knee space below at least 760 mm (30 in.) wide, 480 mm (18-7/8 in.) deep and 685 mm (27 in.) high; and
- insulate or otherwise configure the appliance to prevent burns, abrasions, or electrical shock.

Where classrooms and other training spaces incorporate refrig-

erators/freezers, they shall:

- be configured with at least 50% of the freezer space 1370 mm (54 in.) maximum above the floor; and incorporate *clear space* positioned for a parallel approach to the space dedicated for the refrigerator/freezer, with the centre-line of the *clear space* offset 610 mm (24 in.) from maximum from the dedicated space.

#### RELATED SECTIONS

All relevant parts of Sections 1.0 General Design Standards, 2.0 Exterior Design Standards and 3.0 Interior Design Standards.

# APPENDIX A

## APPENDIX A - UNIVERSAL DESIGN PRINCIPLES

## UNIVERSAL DESIGN PRINCIPLES AND GUIDELINES

Version 2.0 - 4/1/97

Compiled by advocates of universal design, listed in alphabetical order: Bettye Rose Connell, Mike Jones, Ron Mace, Jim Mueller, Abir Mullick, Elaine Ostroff, Jon Sanford, Ed Steinfeld, Molly Story, and Gregg Vanderheiden

Major funding provided by: The National Institute on Disability and Rehabilitation Research, U.S. Department of Education

Copyright 1997 NC State University, The Center for Universal Design

### UNIVERSAL DESIGN:

The design of products and environments to be usable by all people, to the greatest extent possible, without the need for adaptation or specialized design.

The authors, a working group of architects, product designers, engineers and environmental design researchers, collaborated to establish the following Principles of Universal Design to guide a wide range of design disciplines, including environments, products, and communications. These seven principles may be applied to evaluate existing designs, guide the design process and educate both designers and consumers about the characteristics of more usable products and environments.

The Principles of Universal Design are presented here, in the following format: name of the principle, intended to be a concise and easily remembered statement of the key concept embodied in the principle; definition of the principle, a brief description of the principle's primary directive for design; and guidelines, a list of the key elements that should be present in a design which adheres to the principle. (Note: all guidelines may not be relevant to all designs.)

### PRINCIPLE ONE: Equitable Use

The design is useful and marketable to people with diverse abilities.

Guidelines:

- Provide the same means of use for all users: identical whenever possible; equivalent when not.
- Avoid segregating or stigmatizing any users.
- Provisions for privacy, security, and safety should be equally available to all users.
- Make the design appealing to all users.

### PRINCIPLE TWO: Flexibility in Use

The design accommodates a wide range of individual preferences and abilities.

Guidelines:

- Provide choice in methods of use.
- Accommodate right or left handed access and use.

- Facilitate the user's accuracy and precision.
- Provide adaptability to the user's pace.

### PRINCIPLE THREE: Simple and Intuitive Use

Use of the design is easy to understand, regardless of the user's experience, knowledge, language skills, or current concentration level.

Guidelines:

- Eliminate unnecessary complexity.
- Be consistent with user expectations and intuition.
- Accommodate a wide range of literacy and language skills.
- Arrange information consistent with its importance.
- Provide effective prompting and feedback during and after task completion.

### PRINCIPLE FOUR: Perceptible Information

The design communicates necessary information effectively to the user, regardless of ambient conditions or the user's sensory abilities.

Guidelines:

- Use different modes (pictorial, verbal, tactile) for redundant presentation of essential information.
- Provide adequate contrast between essential information and its surroundings.
- Maximize "legibility" of essential information.

- Differentiate elements in ways that can be described (i.e., make it easy to give instructions or directions).
- Provide compatibility with a variety of techniques or devices used by people with sensory limitations.

**PRINCIPLE FIVE:  
Tolerance for Error**

The design minimizes hazards and the adverse consequences of accidental or unintended actions.

Guidelines:

- Arrange elements to minimize hazards and errors: most used elements, most accessible; hazardous elements eliminated, isolated, or shielded.
- Provide warnings of hazards and errors.
- Provide fail-safe features.
- Discourage unconscious action in tasks that require vigilance.

**PRINCIPLE SIX:  
Low Physical Effort**

The design can be used efficiently and comfortably and with a minimum of fatigue.

Guidelines:

- Allow user to maintain a neutral body position.
- Use reasonable operating forces.
- Minimize repetitive actions.
- Minimize sustained physical effort.

**PRINCIPLE SEVEN:  
Size and Space for Approach  
and Use**

Appropriate size and space are provided for approach, reach, manipulation, and use, regardless of user's body size, posture, or mobility.

Guidelines:

- Provide a clear line of sight to important elements for any seated or standing user.
- Make reach to all components comfortable for any seated or standing user.
- Accommodate variations in hand and grip size.
- Provide adequate space for the use of assistive devices or personal assistance.

Please note that the Principles of Universal Design address only universally usable design, while the practice of design involves more than consideration for usability. Designers must also incorporate other considerations, such as economic, engineering, cultural, gender, and environmental concerns, in their design processes. These principles offer designers guidance to better integrate features that meet the needs of as many users as possible.

APPENDIX B



## APPENDIX B - CHANGE ORDER FORM



PROPOSED CHANGES TO THE  
**CITY OF WINNIPEG**  
**FACILITY ACCESSIBILITY DESIGN MANUAL**

**Mail to:** Universal Design Coordinator  
Planning Property & Development Department  
City of Winnipeg  
15 - 30 Fort Street  
Winnipeg, Manitoba, R3C 4X5

**Name:** \_\_\_\_\_

**Address:** \_\_\_\_\_  
\_\_\_\_\_

**Organization:** \_\_\_\_\_

**Phone:** \_\_\_\_\_

**Email:** \_\_\_\_\_

**Proposed Change:**  
(include proposed new or revised wording, or identifications of wording to be deleted)

\_\_\_\_\_  
\_\_\_\_\_  
\_\_\_\_\_  
\_\_\_\_\_  
\_\_\_\_\_  
\_\_\_\_\_  
\_\_\_\_\_  
\_\_\_\_\_

**Reason for Change:**

\_\_\_\_\_  
\_\_\_\_\_  
\_\_\_\_\_  
\_\_\_\_\_  
\_\_\_\_\_

(attach additional information if required)

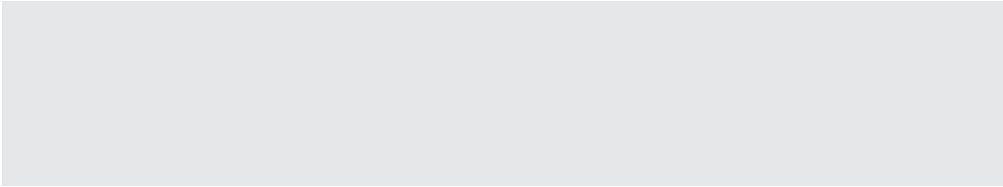

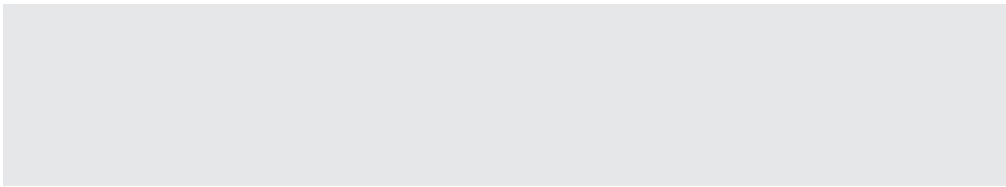

# INDEX

INDEX

- Access aisle* 17, 75, 98, 176, 181  
*Access Width* (see *Wheelchair*)  
*Accessible* 17  
*Accessible element* 17  
*Accessible route* 17, 34  
*Accessible space* 17  
*Active transportation routes* 17, 104  
 Acoustics 53  
*Adaptable* 17, 150  
*Addition* 17  
*Alteration* 17  
 Application 24  
 Appliances 142, 186  
*Area of Rescue and Assistance* 17, 134  
 Arenas 175  
*Assembly Area* 17  
     Acoustics 53  
 Assembly Facilities 75, 169  
*Assistive Listening Device* 17, 169  
*Assistive Listening Systems* 17, 169  
*Attic Space* 17  
*Automatic Door* 17  
 Balconies 91  
 Barrier 18  
 Bathing Facilities 166  
 Bicycle Pathways 105  
 Bike Racks 34, 108  
 Boardwalks 104  
 Bottle Fillers 62  
 Bus Passenger Shelters 108  
 Bus Stop Platforms 109  
 Cabinets 138, 141, 186  
 Cafeterias 176  
*Cane Detectable* 18, 31, 48, 50, 60, 84, 91, 105  
 Canopies 116  
 Card Access 172  
 Carpeting 52, 114  
 Cashier Accommodations 181  
 Change Rooms (see *Dressing Facilities*)  
*Circulation Path* 18  
*Clear space* 18, 28, 48, 50, 59, 62, 69, 99, 108, 119, 136, 141, 146, 151, 156, 158, 162  
 Clearances (see *Wheelchair*)  
 Community Gardens 94  
 Counters 136, 141, 173, 176, 178, 181, 183, 186  
*Closed-Circuit Telephone* 18  
*Colour Contrast* 18  
*Common Use* 18  
 Controls and Operating Mechanisms 170  
 Cook Top 142  
 Corridor 32, 34, 80-114  
 Crawl Space 35  
*Cross Slope* 18, 35  
*Curb Ramp* 18, 36, 44, 50, 60, 81, 87, 89, 100, 106  
*Detectable Warning* 18, 32, 44-51, 89  
     Systems 60-61  
     Surfaces 61  
*Disability* 18  
 Display Units 146  
 Docks 106  
 Dog Relief Areas 97  
 Doors 108, 118, 125, 127, 135, 147, 170, 172  
     Toilet Stall Doors 151  
 Dressing Facilities 147, 175  
     Seating 147  
 Drinking Fountains 62, 106  
     Clearances 63  
 Edge Protection 34  
     at ramps 45  
*Egress, Means of* 18, 134  
 Elevated Areas and Platforms 66  
     Detectable Warning Surfaces 45, 50, 60, 66, 89  
 Elevator 34, 127  
 Elevator Machine Room 10, 35  
 Emergency Exits 134, 182  
 Emergency Services 182  
 Emergency Warning Systems 134, 182  
 Enforcement 11  
*Entrance* 19, 20, 25, 98, 116, 182  
 Entrance Foyer 117  
 Escalators 133  
 Exterior Ground Surfaces 80  
*Facility* 19  
 Faucets 142, 156, 166, 186  
 Fire Evacuation 134  
 Fixed Seating Assembly Facilities 45, 75  
 Floor Surfaces 114  
 Freezer 144  
 Footbridges 105  
 Gate 40, 106, 118, 175  
 Gender 9, 118, 147, 150, 162, 191  
 Glare 38, 51, 53, 56, 81, 106, 114, 170, 173  
 Glazed Screens 125  
 Grab Bar 147, 154, 158, 163, 165, 166  
 Toilet Grab Bar Configuration 154  
*Ground Floor* 19  
*Guard* 19, 32, 44, 46, 73, 75, 91, 94, 104, 121  
 Gymnasiums 125, 175  
 Halls 175  
*Handrail* 19, 36, 48, 51, 68, 104, 129, 147  
     at Pools 72  
     at Ramps 42  
     at Stairs 46  
 Historic Place 74  
 Illumination 37  
     Elevators 129  
     Libraries 179  
     Outdoor Recreational Facilities 106  
     Signage 57  
     Toilet Facilities 151  
     Universal Change Rooms 147  
*Impairment* 18  
 Implementation 8, 24  
*Indicator Surface* 19, 85  
 Information Counter 181

# INDEX

- Information Systems 58
- Intercom System 170
- Interior Floor Surfaces 114
- Interior Glare and Light Sources 174
- Interpretive Panels 58
- Janitor Room 11, 35
- Kitchenettes 141
- Kitchens 141, 186
- Lavatories 156
- Ledge Seating 71
- Libraries 74, 128, 178, 202
- Lighting
  - Elevator 130
  - Exterior 83
  - Interior 173
  - Stairs 46
- Lockers 104, 110, 149, 175 186
- Meeting Room* 19, 140
  - Acoustics 53
- Mezzanine* 19, 48
- Microwave 145
- Multi-Use Pathway* 19, 33, 105
  - Detectable Warning Surfaces 61
- Natural Areas 107
- Newspaper Boxes 84, 108
- Offices 140
- Off-Street
  - Parking 98
- On-Street
  - Parking 98
  - Passenger Loading Zones 102
- Open Space* 19, 55, 141
- Operable Portion* 19, 38, 160, 186
- Outdoor Pools 106
- Outdoor Recreational Facilities 104
- Oven 143
- Overhead Objects 32
- Park* 19, 69, 104
- Parkette 106
- Parking 34, 98, 116
- Parking Spaces 34, 56, 83, 98
- Passenger Loading Zones 102
- Pathways 105
- Patios 84, 91
  - Permanent Patio 80, 93
- Temporary Patio 92
- Pavers 34, 38, 52, 80
- Picnic Tables 95, 106
- Pictograms 56, 170
- Plantings 94
- Platform Lifts 131
- Play Areas 106, 111
- Playgrounds 106, 111
- Playing Fields 104
- Plazas 19, 21
  - Pathway Across Plaza 92
- Power-Assisted Door* 19
- Privacy Screens 158
- Protruding Objects 32
- Public Address Systems 54
- Public Historic Place* 20, 74
- Public Housing 184
- Public Right-of-Way* 20, 55, 64, 84
- Public Use* 20
- Queuing Areas 68
- Railing 19, 36, 72, 84, 91, 104
- Ramps* 20, 34, 42, 48, 73, 105, 114
  - Detectable Warning Surfaces 60
  - Minimum Landing Dimensions 44
- Ramp Slope* 20, 42, 89
- Range 141
- Reach Requirements 31, 141, 175
- Recreation Facilities (Indoor) 175
- Refrigerator 141 187
- Rest Areas 37, 70, 105
- Retrofit* 20
- Roof Space* 20, 35
- Scooter
  - Turning Space 29
- Seating 34, 37, 69, 84, 104, 147, 164
  - Accessible Bench Example 70, 164
- Along Accessible Routes 37
  - at Rest Area 69
  - Streetscape 84
- Security Systems 172
- Service Counter 136, 181
- Service Entrance* 20
- Service Room* 11, 20, 35
- Service Space* 10, 20, 35
- Shelving 146, 175, 178
- Shower Stalls 166
- Sidelights 125
- Sidewalk 9, 20, 34, 80, 84, 89, 105, 108
- Signage* 8, 20, 37, 57, 81
  - Assistive Listening Systems 169
  - Character Height 56
  - Elevators 127
  - Entrances 116
  - Lockers and Storage Units 149
  - Parking 9, 99
  - Passenger Loading Zone 102
  - Toilet Facilities 150
  - Vending and Ticketing Machines 64
  - Washrooms 162
  - Waiting and Queuing Areas 68
- Site Improvement* 20
- Sleeping Accommodations* 20
- Space Requirements 28, 140
- Speaking Ports 20, 136
- Spectator Areas 107
- Spray Pads 72, 106
- Stairs 34, 46, 48
  - Detectable Warning Surfaces 46
  - Landing Criteria 46
  - Lighting 46
  - Nosings 46
  - Treads 46
- Steps 46, 72, 81, 105
- Storage 140, 141
  - Reach Limits 146
  - Units 149
- Storage Elements 141, 186
- Street Elements* 20, 84



- Street Element Zone 20, 85
- Streetscape* 20, 84
- Structural Frame* 21
- Swimming Pools 72, 106
- Tables 138
- Tactile* 21
- Temporary Facility* 21
- Texture 36, 38, 42, 46, 51, 59
- Ticketing Machines 64,
- Toilets 151, 152, 154, 175
- Toilet Stalls 152
- Traffic Signal Poles 87
  - Locations on Street 88
- Trails 105
- Training Facilities 185
- Transfer Space 153
- Transfer Systems 111
- Transit Facilities 108
- Tree 34, 94, 105
- Tree Guard 34, 94
- Truncated Dome* 21, 36, 51, 61
- Truncated Dome Detectable
  - Warning Surfaces 89
- Turning Space (see Wheelchair)
- Turnstiles 40, 118, 177
- Universal Change Rooms 72, 104, 147, 175
- Universal Toilet Rooms 151, 162
- Utility Boxes 34, 84
- Urinals 158
- Vehicular Way* 21
- Vending Machines 64
- Video Display Terminals 58
- Visitable* 21, 184
- Visual Alarms 134, 168, 183
- Waiting Areas 68, 102, 118
- Washrooms 106, 150-165  
(see Universal Washrooms)
- Washroom Accessories 160
- Washroom Dimensions 150
- Waterfront Areas 106
- Wayfinding* 21, 34, 51, 55, 58-74, 89
  - Acoustics 53
- Wheelchair
  - Access Widths 35
  - Access at Turnstiles 40
  - Clearances 28-63, 85, 178
  - Doorways 119
  - Maneuverability 28-29
  - Ramp 42
  - Reach Allowances 30
  - Sight Lines in Assembly Seating 76
  - Turning Around an Obstacle 35
  - Turning Space 29
- Window 125
- Window Sill 125
- Work Areas 140
- Work Surfaces 138, 140, 174, 178
- Workplace Accommodations 181

