

## FLOOR DIAPHRAGMS AND A TRUSS METHOD FOR THEIR ANALYSIS

**J.M. Scarry<sup>1</sup>**

(Submitted *May 2014*; Reviewed *August 2014*; Accepted *December 2014*)

### ABSTRACT

Floor diaphragms form a critical component of seismic resistant buildings, but unfortunately, in the main their analysis and design in New Zealand leaves much to be desired. No worse example exists than the CTV Building in Christchurch. Despite the critical importance of diaphragms, there is a paucity of code provisions and design guidance relating to them.

Using generic examples, the author describes a number of common diaphragm design deficiencies. These include diaphragms where valid load paths do not exist; diaphragms where the floors are not properly connected to the lateral load resisting elements, diaphragms that lack adequate flexural capacity and where re-entrant corners are not properly accounted for, and transfer diaphragms into which the reactions from the walls above cannot be properly introduced or transmitted.

Three main types of seismic diaphragm action are discussed – ‘inertial,’ ‘transfer’ and ‘compatibility.’ These are, respectively, the direct inertial load on a floor that must be carried back to the lateral load resisting elements, the transfer forces that occur when major changes in floor area and lateral load resisting structure occur between storeys, and the compatibility forces that must exist to force compatible displacements between incompatible elements, such as shear walls or braced frames and moment frames, or as a result of redistribution.

The author presents a simple Truss Method that allows complex diaphragms to be analysed for multiple load cases, providing accurate force distributions without the multiple models that conventional strut and tie methods would require. Being a type of strut and tie method, the Truss Method is compliant with requirements in NZS3101:2006 [1] to use strut and tie models for the analysis and design of certain aspects of diaphragm behaviour.

### INTRODUCTION

With regard to the seismic resistant design of buildings in New Zealand (NZ), a great deal of attention is given to the *vertical* lateral load resisting elements (moment frames, shear walls and bracing) at university, in the code compliance documents and standards, in texts, guides and seminars, and in design office and Building Consent Authority practice.

Unfortunately, the equally critical *horizontal* lateral load resisting elements (diaphragms) are often given little consideration in NZ, and the analysis and design effort that does go into them is often woefully deficient. There needs to be an immediate improvement in overall attitudes and office practice regarding diaphragms.

The floor diaphragms hold the building together, and prevent all of the vertical elements from buckling. They are the repository of most of the weight in a building, and unless the diaphragms can sustain the seismic forces they are subjected to, and transfer those forces properly to the vertical lateral load resisting elements, those vertical lateral load resisting elements may as well not be there.

Several factors seem to conspire in NZ to prevent diaphragms being treated with the respect they deserve, and being given the significant design effort they require. They have received little attention in the lectures and notes at university, although that is improving, and they appear to receive little attention from academics, Des Bull being a notable exception. This is perhaps because of their large size and hence the difficulty in testing them. They receive little coverage in engineering texts, they receive only slight and partial coverage in the structures

standards, the usually valid assumption of being ‘infinitely rigid’ may lead to the assumption of ‘infinite strength’ as well, they are very difficult and time consuming to analyse and design properly, except for the most trivial of configurations, and the fees and time required for that analysis and design are often not there. This paper aims to change that.

Figure 1 shows a simply supported steel beam subject to gravity loading. In simplistic terms, the web resists the shear forces, the flanges resist the bending actions that must exist for equilibrium, and robust connections ensure the loads are transferred to the supports.

Figure 2 is a more complex beam, with a reduction in section, a notch and a web opening. However, all of these items appear to have been accounted for through appropriate strengthening following detailed rational analysis and design.

One likes to think that standard design office practice, supported by available design guides, would ensure that both these steel beams would be rigorously analysed, designed and detailed to produce safe, robust structures.

Now imagine that these beams are turned on their side, increased in dimension by a factor of ten or more, and converted to reinforced concrete. In other words, they become floor diaphragms. All too often, the design paradigm changes completely. A rudimentary check of the overall shear strength may be made, but most of the other actions will be ignored. In many instances, there will not even be robust connection of the floor diaphragm to the very lateral load resisting elements that are put there to support the diaphragm in the first case.

<sup>1</sup> Structural Engineer, Auckland, NZ, [jmscarry@extra.co.nz](mailto:jmscarry@extra.co.nz)

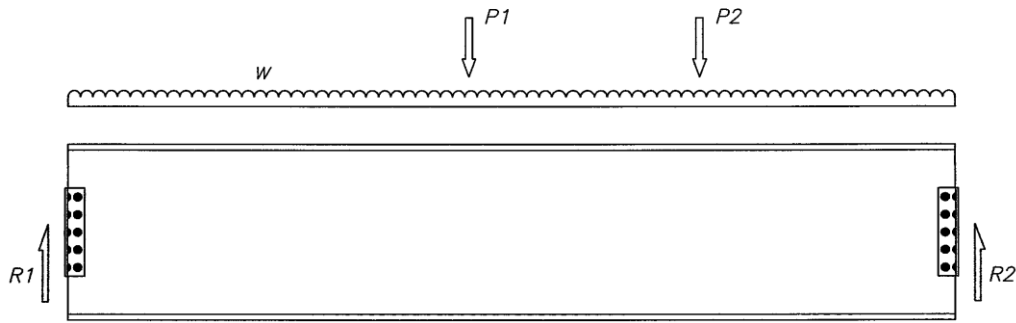

Figure 1: Diaphragm - beam analogy - simple beam.

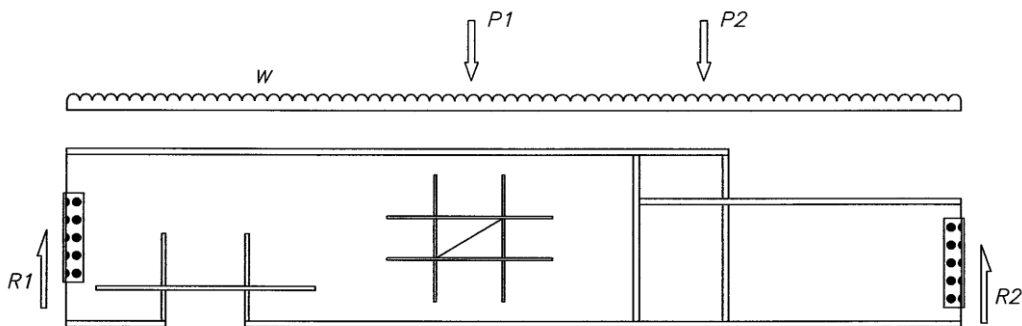

Figure 2: Diaphragm - beam analogy - complex beam.

This paper aims to draw the profession's attention to the need for the proper analysis and design of diaphragms. Through examples, it shows how the viability of a diaphragm can often be assessed very quickly, simply by inspection, and describes a simple but effective truss analysis method that can handle what is often an extremely complex analytical problem with relative ease.

The emphasis is on cast reinforced concrete slabs, pre-cast concrete floor units with *in-situ* toppings, and concrete filled metal deck floors acting compositely with steel beams. The reader should refer to standards such as NZS3101 [1] and NZS3404 [2], and relevant papers, such as those produced by Bull [3], for guidance on the detailed design of the reinforced concrete and structural steel components that form a typical diaphragm.

Moehle *et al* [4] and Sabelli *et al* [5] provide interesting background reading, but caution should be exercised, particularly with regard to the inertial forces that should be applied. These papers make mention of the compatibility effects that can develop in diaphragms as a result of having lateral load resisting elements with different stiffness and deformation characteristics, under the term 'transfer forces,' but do not follow through in detail. These compatibility effects can be very large, especially in tall buildings.

The papers by Cowie *et al* [6, 7] are of interest for their use of the inertial loading method (with height limitation) developed by Uma *et al* [8].

Another word of caution: As with all engineering standards and design guides, do not accept the standards and guides relating to diaphragms as 'gospel.' Check the content and the details proposed against sound engineering principles and (un)common sense. Just because "it's in the standard" (the fallacious *argumentum ab auctoritate*) or "everyone else does it this way" (the fallacious *argumentum ad populum*) does not make it right. Particularly bear in mind the fact that recent

studies at the University of Canterbury aimed at confirming the exact nature of inertial loads that should be used for the analysis and design of diaphragms have superseded guidelines in even very recent papers.

Refer to the upcoming Ministry of Business, Innovation and Employment (MBIE) recommendations for diaphragm design. In the meantime, seek expert advice.

Untopped diaphragms with discrete connections, usually in the form of embedded weld plates, are not considered in this paper. They are, in the opinion of the author, a concept that should not be used to resist seismic loads, or even significant shrinkage or thermal effects.

This paper draws the attention of the reader to the types of loads that various types of diaphragm are subjected to, with appropriate references, but does not cover the derivation of these loads in detail, because space does not allow the subject to be covered properly.

Space also prevents the inclusion of as many diagrams as would be desirable. Please pay particular attention to the details of the text – there are many important points which may not be highlighted through the inclusion of an accompanying diagram.

The author is indebted to Chris Thom, PhD, for reinforcing an already developing appreciation of the importance of good diaphragm design, back in the mid-1980s. Chris carried out the preliminary design for a proposed multi-storey hotel in Wellington. Reinforced concrete shear walls provided the lateral load resisting system to the tower, with a four storey podium structure surrounding the bottom of the tower. The tower floors were to be precast concrete units with *in-situ* topping, but the podium slabs had to be cast *in-situ*, because of the magnitude of the transfer diaphragm forces.

The central shear core had two C shaped shear walls, with the floor slabs attached to the full length of one side of the web of

each shear wall. The force transfer from these walls at the top floor of the podium was so great that the *in-situ* floor slab in the vicinity of the shear walls had to be 600 mm thick, with numerous drag bars projecting from both ends of each shear wall web, to complement the force transfer through the side of the web.

The thickness of the *in-situ* slab in the top floor of the podium reduced to 200 mm at the surrounding podium walls, and the variation in thickness across the slab was based on an assessment of both strength and the propensity of the slab to buckle. All of this was done without specific code provisions or papers such as this. It simply resulted from a competent engineer applying the principles of equilibrium, a load path and resistance to buckling.

### EXAMPLES OF POOR DIAPHRAGM DESIGN

Poor diaphragm design featured significantly in the author's Open Letters [9, 10], particularly in the First Version [9], and several examples were shown. At the time, the author had not developed the Truss Method, and so the proper assessment of the internal actions in these example diaphragms was difficult, but by inspection, the diaphragm designs simply could not be right. Large openings surrounding shear walls or irrational geometries showed that viable load paths and dependable performance could not be achieved.

Over 60% of the fatalities in the Christchurch earthquake on 22 February 2011 were due to the collapse of one modern building – the CTV Building. A major contributory factor to the collapse was the woefully deficient floor diaphragms. The

building was almost completely dependent on the shear walls of the North Lift Core for its strength and stability, but there was no effective connection of the floors to that core.

Figure 3 shows a typical floor plan. In the north-south direction, there were originally no drag beams or even drag bars to connect the floors directly to the walls. Only the western bay of the core had direct connection to the north-south direction walls, and the 'drag angles' that were retrofitted to the eastern bay did not extend into the main body of the floor. The situation in the east-west direction was no better. The building was completely dependent on the connection of the floors to the rear north wall of the core. But large openings for the lifts, the stair and services (shaded in black) meant that the length of floor connected to this wall was very limited, and even then, the floor system was not capable of resisting the resultant 'cantilever' bending actions in the diaphragm.

The main load carrying structure of the CTV Building was described as a 'shear wall protected gravity load system.' This was a common form for many mid-rise Christchurch commercial buildings designed in the 1970s and 1980s, although these other buildings at least had the shear core within the footprint of the building.

Unfortunately, often little attention was paid to the diaphragm design and invariably, low ductility welded wire mesh in the floor topping was used as the main diaphragm reinforcement. After 22 February 2011, some of these buildings had to have large angles bolted in place to connect the floors to the shear core, simply to make the buildings safe enough to demolish.

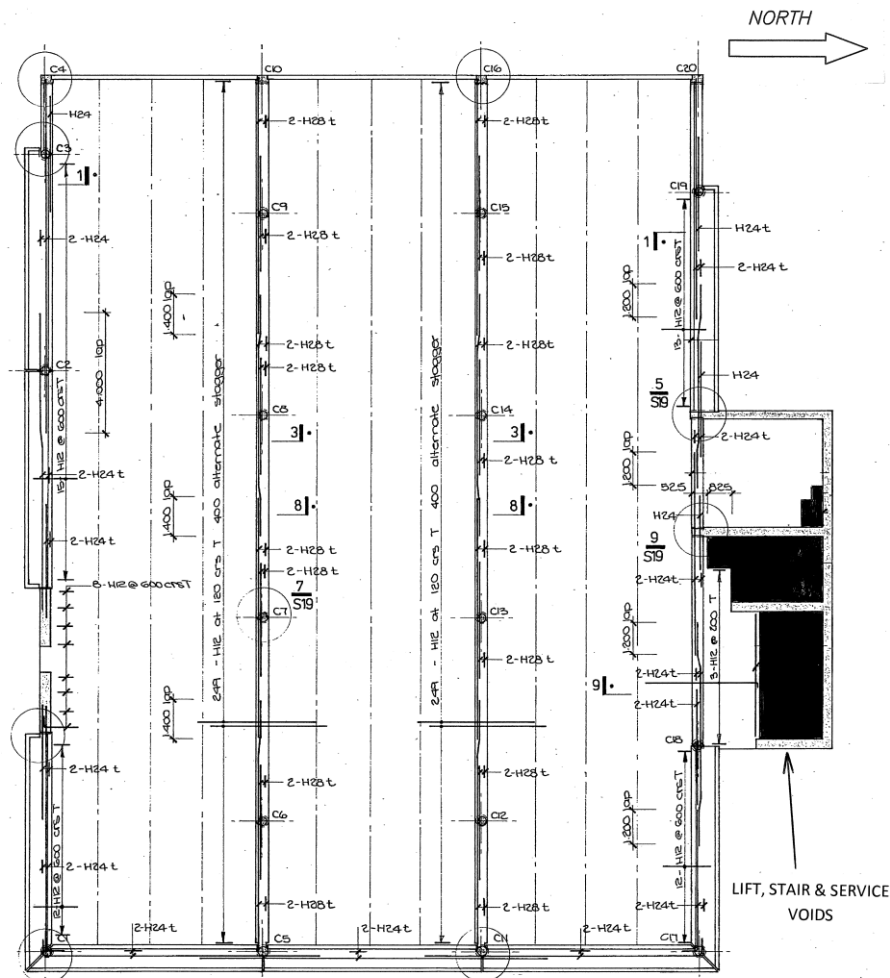

Figure 3: Typical floor plan of the CTV building, Christchurch.

Yet despite weeks of streaming evidence from the Canterbury Earthquakes Royal Commission (CERC) regarding the CTV Building, and the written findings, at least one multi-level structure of the re-build was designed and constructed with this same fundamental defect – inadequate connection of the floors to the lateral load resisting elements. In the building the author has dubbed ‘Son of CTV,’ in one direction the lateral load resisting elements were located on the outside of external stair wells, without any effective load path from the main floors to the lateral load resisting elements. The deficient design was reviewed and consented, and this serious deficiency was only discovered by good luck during construction through some observant engineers not involved with the project. Hopefully, the retrofit that followed is more effective than that applied to the CTV Building.

In the following examples, the gravity load resisting structure has generally been omitted for clarity, and any indicated seismic loading is diagrammatic only, and would obviously vary to account for the  $\pm 0.1b$  eccentricities required by most loadings standards.

Figure 4 shows the all too familiar case of large openings around the shear walls. Unfortunately, in this case, the openings are very large and on both sides of the shear wall webs, so that the shear walls have little effective connection to the building in one direction. Another problem is the fact that the webs have no connection to each floor, and web slenderness is a serious issue given the large length of the web relative to its thickness.

Concrete structures standards continue to assume that wall elements are restrained at each floor level, and this is clearly often not the case.

Figure 5 was a concept for an extension to a large building, driven by the architect stating he did not want bracing at the far end of the extension. It was proposed that each floor would cantilever horizontally off the strut and the connection of the floor topping back into the main building. If this was a vertical shear wall, the author believes it would have been dismissed outright, and such forms appear in all sorts of texts and guides as what *not* to do in a seismic zone, but because it was a diaphragm, in this instance it was considered viable. The engineer tasked with implementing this design had to fight to correct this, and at least ensured that this extension got adequate bracing at the far end.

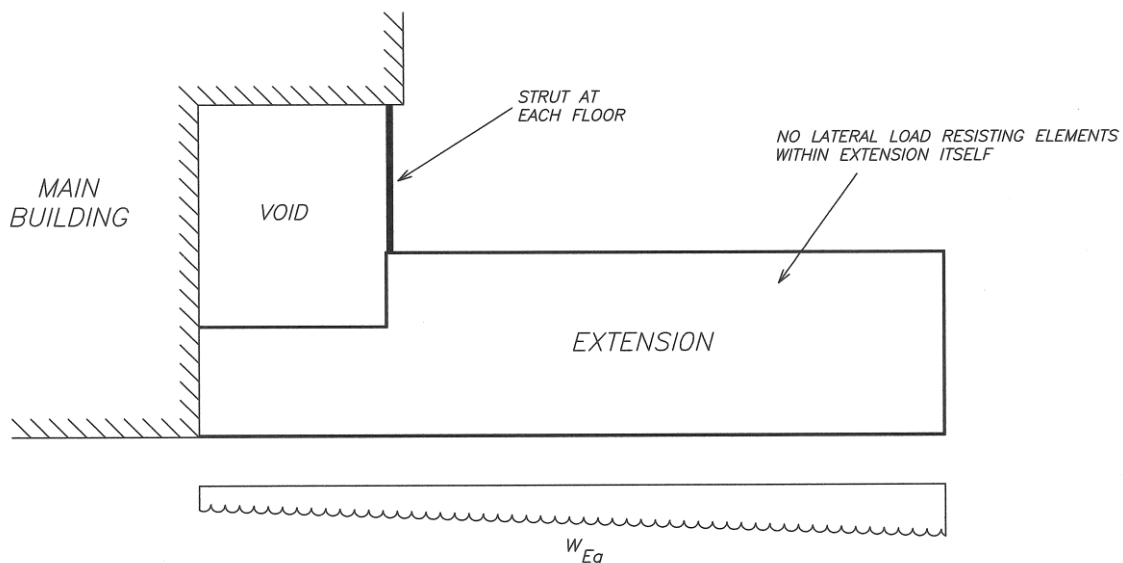

Figure 5: Horizontal cantilevering of floors off re-entrant corner.

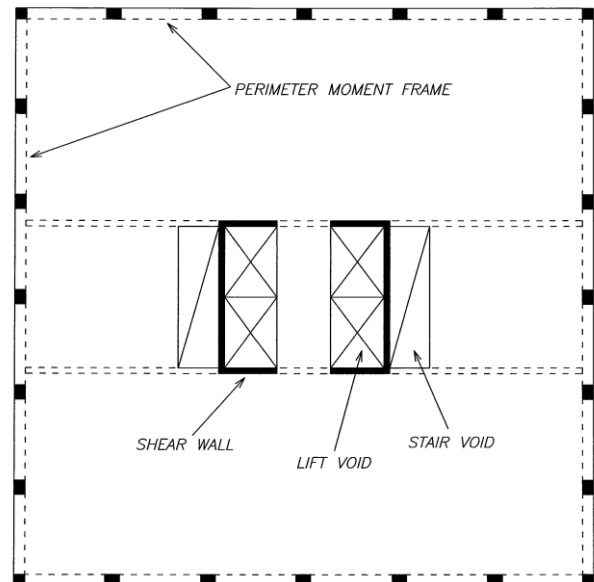
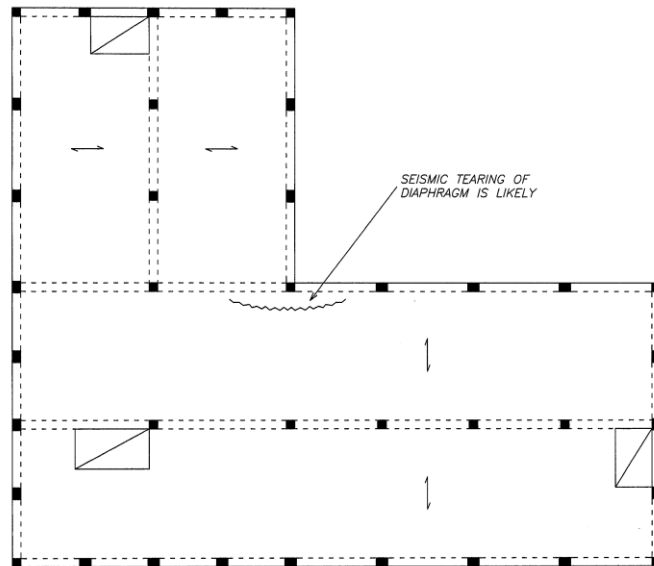

Figure 4: Voids surrounding shear core.

Ideally, buildings in seismic zones should have a simple, stocky rectangular floor plan, with a symmetrical arrangement of vertical lateral load resisting elements. Figure 6 shows a not uncommon but undesirable L shaped floor plan. L shaped diaphragms are very prone to ‘tearing’ at the re-entrant corner, even if our conventional treatment of seismic load and our analysis methods cannot always identify the actions that would cause this tearing. Such re-entrant corners should at least be strengthened with ‘stiffeners’ in *both* directions, in the form of beams extending well into the building.

Figure 7 is not such a bad overall concept in itself, but when submitted for a Building Consent, a simple check showed that the diaphragm-wall interface (simply the topping thickness over the length of each wall) was overstressed.



**Figure 6: Inadequately strengthened re-entrant corner.**

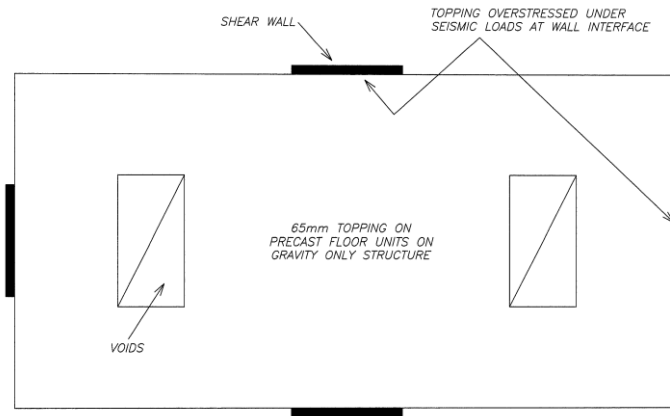

**Figure 7: Overstressed diaphragm - wall connections.**

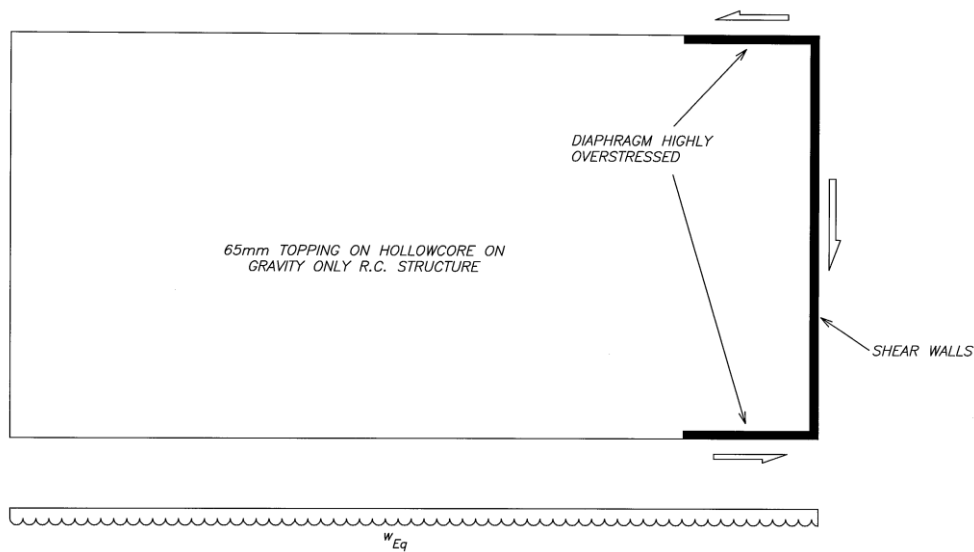

**Figure 8: Cantilevering diaphragm designed as simply supported.**

Figure 8 shows a very large suspended concrete floor, which had a lightweight steel structure over the top. The gravity system included precast concrete floor units with 65 mm topping and low ductility mesh, supported on a gravity only

reinforced concrete frame structure. Shear walls at one end were intended to resist all of the seismic loads. The seismic actions on the walls were determined through an ETABS analysis [11]. Clearly, the floor must 'cantilever' off the three

shear walls, but an engineer ‘designed’ the diaphragm as ‘simply supported,’ for a bending moment of  $wL^2/8$ , and a shear force of  $wL/2$ . The reviewing engineer’s quick check showed the shear stresses in the diaphragms adjacent to the ‘flange’ walls were almost twice the maximum allowed. After much wasted effort in trying to get the design firm to solve the problem in a rational manner, the reviewing engineer and the author were engaged to determine how many shear walls needed to be added to the opposite end of the building to make the diaphragm work. The author developed the first version of the Truss Method for this purpose, and it allowed alternative strengthening arrangements to be quickly checked.

The Truss Method was described by a colleague to another consulting engineer, to assist that engineer in designing a large L shaped floor diaphragm. This consulting engineer duly analysed the diaphragm, and the results showed very large axial force components at the re-entrant corner of the L. The consulting engineer then wished to ignore these large forces, because he considered them ‘errant.’ They were not – they were demanded by simple equilibrium.

## TYPES OF ULTIMATE LIMIT STATE LOAD DIAPHRAGMS MUST RESIST

### Inertial Loads

#### *Magnitude*

All suspended floors will be subject to direct lateral acceleration and hence lateral inertia forces during an earthquake, including diaphragms also subject to transfer and compatibility forces.

Recommendations as to what method should be used to determine these floor accelerations and forces include:

- (a) The Parts and Portions provisions of the appropriate loadings standard,
- (b) Parts and Portions as modified by Uma *et al* [8], as described in Cowie *et al* [6, 7],
- (c) The Pseudo-Equivalent Static Analysis (pESA) method developed by Gardiner *et al* [12],
- (d) Later developments of the pESA method,
- (e) A Response Spectrum Analysis,
- (f) A non-linear time history analysis.

Before discussing these methods in detail, the author wishes to make one important point that he will elaborate on below. For buildings in which compatibility effects are significant, especially tall buildings containing several lateral load resisting systems with different deflection characteristics it is in general *not* conservative to over-estimate the inertial load on a particular floor, especially near the top of the building. In many instances, the ‘kick back’ compatibility actions near the top of the building will be larger than, and in the opposite direction to, the inertial forces. Therefore, any over-estimation of the inertial forces in these floors will reduce the actions that should be designed for, and is therefore unconservative.

Parts and Portions and the modified Parts and Portions method by Uma *et al* [8] are self-explanatory. Note in the Cowie *et al* paper [6] describing the Uma method that there is a height limit. It appears the Parts and Portions method in AS/NZS 1170.5 [12] can result in over-estimates of the floor accelerations.

The Pseudo-Equivalent Static Analysis method developed by Gardiner *et al* [13] is based on the Equivalent Static Method, scaled up for the overstrength of the building, and with increased accelerations for the lower floors, based on the peak

ground acceleration. The overall ‘acceleration envelope’ is given by the intersection of the inverted triangular loading with the vertical PGA line. The PGA feature overcame the unrealistically small accelerations imposed on the lower floors through the inverted triangular shape of the Equivalent Static Method. This method was limited to buildings 9 storeys high. For taller buildings, with their longer periods and reduced total building spectral accelerations, the pESA method breaks down, because the PGA becomes greater than the accelerations on the top floor(s). Through the Equivalent Static Method, this method involves ‘lumping’ 8% of the base shear at the top floor, to account for higher mode effects. This will most likely be unconservative for a building in which compatibility effects are significant.

The latest development of the pESA method maintains the Equivalent Static Method scaled up for the overstrength of the building, but removes the requirement to apply the PGA over the lower floors. Instead, ‘design judgement’ is required to assess what accelerations should be applied to the lower floors.

We should not be designing highly eccentric buildings. Therefore, the author favours the following approach for deriving the inertial forces acting on floors in relatively regular tall buildings where compatibility effects are significant. With the centre of mass not offset, carry out a response spectrum analysis in each principal direction, with the base shear scaled up to a minimum of the equivalent static base shear. From the storey shears, calculate the resultant force, and hence acceleration, acting on each floor. Then scale these forces/accelerations up by the building overstrength factor, unless ductility factors of  $\mu = 1.25$  for a reinforced concrete building or  $\mu = 1$  for a steel framed building were used. Then apply these scaled actions as static inertial loads with appropriate signs to the diaphragm model. The storey shears need not be scaled up above the ‘elastic’ values. Such an approach will include the higher mode effects, and the total base shear will be the same as the proposed pESA method, but potentially unconservative ‘lumping’ of inertial loads where they would not otherwise occur is avoided. Again, some increase in accelerations for the lower floors should be considered, based on engineering judgement and expert advice.

Always be very careful when using and interpreting the results of a response spectrum analysis. The output is always without sign – all numbers are positive. Careful interpretation of the results will be required to derive correct bending moment diagrams, the direction of shears and hence force transfer, and the like. With regard to diaphragms, it is critical to look at the overall structural system to determine the diaphragm loads at each floor level. For example, in a uniform high rise shear wall building projecting above a stiff podium structure, the inertial load on each upper floor will be the difference in the storey shears at each level, because the shear forces all act in the same direction. But for the transfer diaphragm floor at the top of the podium, the total seismic force acting on that diaphragm will equal the sum of the storey shears above and below, due to the orientation of forces required for the stiff podium to ‘prop’ the tower and resist overturning.

For very irregular structures, the inertial (and other) loads acting on the diaphragms may have to be derived directly or indirectly through the use of a non-linear time history analysis. This is a very complex method of analysis which should only be carried out by suitably qualified and experienced engineers. Expert advice must be sought, and independent expert review will be required as well.

It is stating the obvious, but all inertial (and other) loads must be applied as load vectors, with the appropriate signs (directions). Seismic loading must be applied in both the

positive and negative directions for each principal axis. This is especially so when using strut and tie methods of analysis.

#### Line of Action

It is the author's opinion that if overstrength actions are applied to the diaphragm, then the  $\pm 0.1b$  eccentricity can be ignored, because an envelope of maximum actions is being applied.

However, for diaphragms subject to elastic or nominally ductile actions, the  $\pm 0.1b$  eccentricity must be allowed for.

We know that torsional response places additional demand on the lateral load resisting elements, especially as these elements crack and yield at varying rates, increasing the torsional demand. The diaphragms must also be subjected to increased demand as a result.

Varying the mass across a diaphragm to achieve the  $\pm 0.1b$  eccentricity of mass can require changes of the order of  $\pm 40\%$  of the masses each side of the centre of mass (COM). However, unless there are many distributed lateral load resisting elements, the resultant increase in localised diaphragm actions as a result of this eccentricity is likely to be in the order of 10%, with an upper limit of 20%.

Some preliminary calculations may indicate an appropriate scale factor for elastic/nominally ductile loads acting through the COM, to account for eccentricity effects. At the very least, scale up the loads by 10%.

More studies are required on this, and during an earthquake, softening or weakening of one shear wall relative to another wall in close proximity may generate considerable increases in local diaphragm actions.

Refer to a later section for a discussion of 'biaxial' effects.

#### Transfer Forces

Transfer forces occur at floors where there are changes in the layout of the lateral load resisting elements. This is usually accompanied by a change in the shape and size of the floor plates.

The most well-known type of example where significant transfer forces develop can be seen in Figure 9, in which a tower is surrounded by and connected to a larger podium structure that is significantly stiffer than the tower. Instead of cantilevering off its foundations, the tower receives most of its stability against lateral loads from the top floor(s) of the podium, with a 'kick back' at the base. Very large floor forces (and wall shears) can develop, and these must be transferred from the tower into the top floor diaphragm(s) of the podium, and carried out to the stiffer lateral load resisting elements (usually shear walls) of the podium.

For ductile or limited ductile tower structures, the transfer forces must be based on overstrength values.

For diaphragms where shears are required to be re-distributed in plan between different vertical lateral load resisting elements, a transfer of forces through the diaphragm must also occur.

#### Compatibility Forces

Instead of relying solely on one type of lateral load resisting element, some buildings incorporate mixed shear walls and moment resistant frames or mixed bracing and moment resistant frames. This is often done to increase the strength and improve performance at the ultimate limit state, for example by reducing the risk of a storey sway mechanism developing.

In other instances, mixed systems are used deliberately to reduce the lateral deflections, for the reasons that follow.

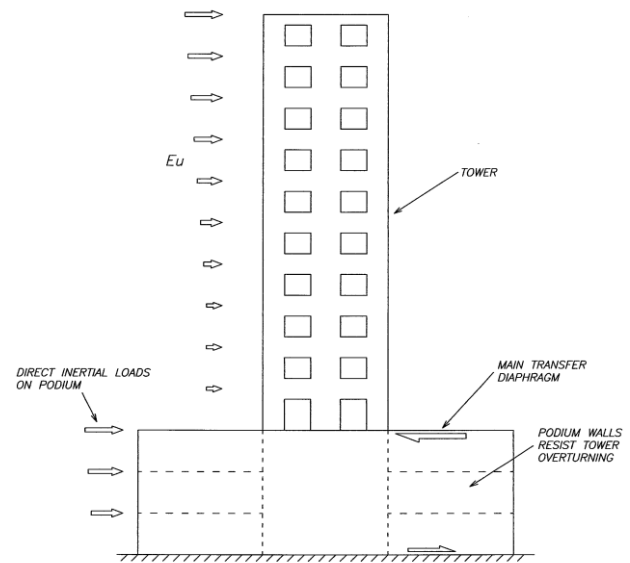

Figure 9: Transfer forces in towers with podiums.

Figure 10 shows the deflected shapes of a moment resistant frame and a cantilever shear wall under lateral loading. Interstorey deflections tend to be greater in the lower parts of the frame, and greater in the upper parts of the shear wall. When the two structures are combined in a building and tied together with floor diaphragms, they 'fight' each other. The deflected shape of both structures is changed, and overall, deflections are reduced as a result.

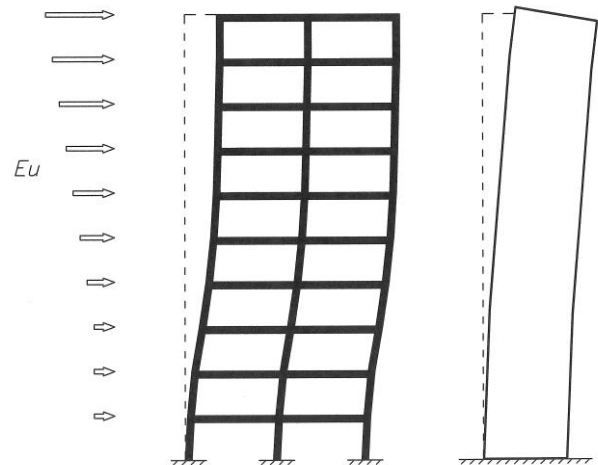

Figure 10: Incompatibility of frame and wall deflection profiles.

One consequence, however, is that very large forces develop in the floor diaphragms as compatible deflections are imposed.

Unfortunately, whereas the rigid diaphragms usually assumed in the analysis of multi-storey buildings impose compatible displacements, they provide no information as to the magnitude of the force components in the slab required to enforce compatibility.

Determining these compatibility forces is not a simple task. Modelling a floor with triangular or rectangular finite elements will include the compatibility forces in the form of element stresses, but extracting those forces in a useful form

will be difficult if not impractical.

Alternatively, the floor diaphragms at each level of the building could be included in a three dimensional model of the building using truss elements, either the non-linear lattice elements or the simple truss elements described in the Truss Method.

Inertial loads could be distributed to all of the nodes in a floor to represent the seismic loading on the building, and the truss forces will be the resultant of the inertial and compatibility effects.

Infinitely rigid diaphragms can increase the compatibility effects in a 3D model. Real floors are not infinitely stiff, and even the very small flexibility present in a real floor (which can be accurately modelled using truss diaphragm models) can produce a noticeable reduction in what are still very large compatibility forces.

These compatibility effects will result from the elastic deformation profile. However, the problem becomes much more complex when the inelastic deflection profiles described in AS/NZS 1170.5:2004 [12] Section 6.5 and Section 7 have to be considered. A special study, including appropriate expert advice and review, should be carried out. Maximum effects may occur when some walls/frames have fully yielded and others are still largely elastic.

Compatibility effects will exist to some extent in all realistic diaphragms because the lateral load resisting elements will not be perfectly uniform and symmetric.

Tearing forces due to plastic hinge elongation in reinforced concrete moment frames with precast floors are another type of localised compatibility effect. In Christchurch, severe damage was caused to some floor diaphragms by such plastic hinge elongation. For a discussion of this form of damage, and other related problems, refer Bull [3].

### Lateral Restraint Forces

All diaphragms must provide lateral restraint to all beams, columns, walls and braces that require it.

It must not be assumed that all vertical elements are automatically restrained by a floor, especially with regard to walls. All details must ensure that the required restraint is provided, especially with respect to elements near slab openings and free edges.

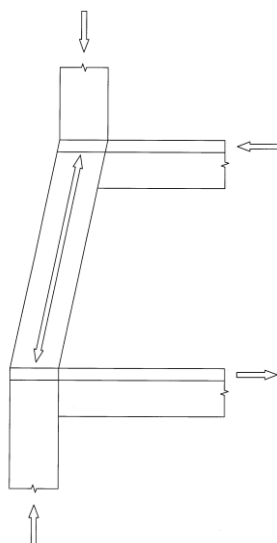

Figure 11(a): Diaphragm forces due to inclined column.

### Static Forces

Suspended floor diaphragms are of course subject to wind forces above ground level.

Often, the lower part of a building will be required to retain soil, and sometimes ground water. 'At Rest' soil conditions usually apply, because of the inherent stiffness of the building system at these levels.

Usually, these static retaining loads will have to be carried by diaphragms, either to transverse shear walls or other lateral load resisting elements, or across the building to oppose retained soil (and ground water) acting in the opposite direction. In other cases, lateral loads from the building will be reacted against retained soil, with these lateral loads being transmitted through the floor diaphragms.

Under earthquake conditions, seismic forces from the soil, in addition to the static retaining forces, are generated.

Sloping and offset columns can also generate very large forces in diaphragms.

### Sloping and Offset Columns

Sloping and offset columns, such as those shown in Figures 11(a) and 11(b), can generate very large diaphragm forces, especially in high rise buildings.

Unfortunately, the large diaphragm forces required to resist the horizontal components from the inclined column force will not show up in most three dimensional computer analyses, because of the rigid diaphragms usually used to model the in-plane stiffness of the floors. Therefore, these horizontal force components must be determined by additional analysis.

### A Special Type of Slab on Grade

In low rise shear wall buildings in particular, a common problem relates to the foundations of the shear walls. Often these walls carry little of the total weight of the building, hence their foundations have limited resistance to sliding, or the walls bear on piles with negligible lateral load resistance, yet the shear walls must resist the seismic loads from the whole building. As a consequence, what would otherwise be essentially a non-structural slab on grade must act as a transfer diaphragm, tying in the shear walls and transferring the seismic shears to gravity foundations or embedded foundation beams, where the shears can be resisted by friction or horizontal bearing against the soil.

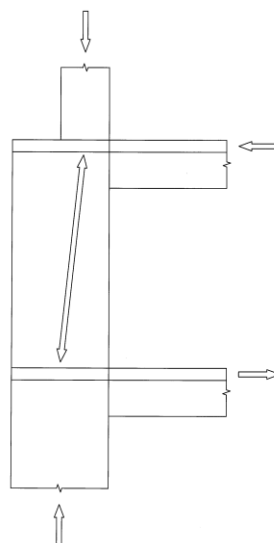

Figure 11(b): Diaphragm forces due to change in column size.



### **‘Biaxial Attack’ on Diaphragms, and Combination of Inertial Loads with Others**

At present, there are two schools of thought regarding ‘biaxial’ seismic loads acting on diaphragms. One school says that each principal direction can be considered independently, the other does not.

The author is of the second school, for several reasons.

In the general case for a non-seismic diaphragm, loads will often be applied in both principal directions simultaneously. Retained soil loads will often act on more than one side of a basement, and offset and sloping columns are often not ‘uni-directional.’

With regard to seismic loading, for a ductile or limited ductile building, yielding of lateral resisting elements in different directions must be assumed to be occurring simultaneously. That is what the capacity design methods require, with the consequent development of very large overstrength axial loads in ‘corner’ columns, for example. The diaphragms must be subject to these overstrength effects in both principal directions simultaneously as well. The advantage of the Truss Method described in this paper is that multiple load cases and multiple load combinations can be easily handled by the one model.

For buildings that are ‘elastic’ ( $\mu = 1$ ) or ‘nominally ductile’ ( $\mu = 1.25$ ), AS/NZS 1170.5:2004 Section 5.3.1.2 requires that the action set comprise of 100% of the earthquake actions in one direction combined with 30% of the earthquake actions in the orthogonal direction. A review of the member actions for each direction of loading alone may show that a suitable scaling factor (typically a 10% increase) would allow each principal direction to be considered separately, and still comply with the requirements of Section 5.3.1.2.

Seismic actions in diaphragms should not be considered separately from other (static) diaphragm actions.

Some engineers suggest that when combining inertial loads with overstrength or elastic transfer forces acting on a transfer diaphragm, a square root sum of the squares (SRSS) combination of these actions should be used, because the peak values of each will not occur simultaneously. The author disagrees with this, and considers that these loads should be assumed to act in the same direction simultaneously. With any strut and tie method, including the proposed Truss Method, one simply has to know which members are in compression and which are in tension, because that actually defines the structural form of the diaphragm. SRSS combination causes all signs to be lost. If nothing else, considering the inertial and transfer actions to act simultaneously in the same direction greatly simplifies the handling of the results, and does not require the engineer to manually re-assign the sign of each member force.

## **PRACTICAL CONSIDERATIONS**

### **Layout**

It is essential that at the earliest stages of developing the form of a building, the diaphragms are given as much consideration as any other architectural or structural element, if not more so.

At present, diaphragms are invariably ‘designed’ late in the design phase, if at all. For many of the bad examples shown in Figures 4 to 8, major changes in the layout of the building or at least parts of it would be required if sound seismic resistant diaphragms are to be the result. This cannot occur late in the design process without causing major problems.

Before a preliminary layout is finalised, the structural engineer

should sketch the compression and tension load paths he/she envisages in the diaphragms for each load case. Positive connection of the lateral load resisting elements to the diaphragm must be demonstrated, and that all steps, openings and re-entrant corners allow positive load paths to develop. Specific attention to the actual restraint conditions and real slenderness of walls must be given, and the layout of stairs, lift shafts, and other openings near walls should allow for reasonable increases in wall thickness should final design require this.

In general, diaphragms should have a good ‘backbone’ in the form of edge beams to resist the flexure in the diaphragm, and ‘stiffeners’ in the form of beams trimming any opening or re-entrant corner, which extend sufficiently back into the slab to dissipate any large components of force. Drag and collector beams should be used to transmit diaphragm forces to the lateral load resisting elements where the direct connection is inadequate. For steel frames, moment end connections should be used for the members forming the ‘backbone,’ the ‘stiffeners’ and the drag/collector elements – for strength, redundancy, and to avoid the eccentric connection effects that are present in many pinned connections.

The reader should refer to Figure 1.11 and Figure 1.12 of Paulay & Priestley [14] for examples of undesirable diaphragm geometries, and preferred alternatives.

The most economic and best performing diaphragms will be the simplest – the K.I.S.S. principle applies especially to diaphragms – *keep it simple stupid*.

### **Diaphragm Size, and Serviceability Limit State Effects**

The first consideration in the layout of a diaphragm is its size. Any floor incorporating concrete will be subject to the serviceability limit state actions of creep, shrinkage and temperature. For larger floors, these effects can be significant, and can be exacerbated by layouts of lateral load resisting elements that restrain free movement. The thin toppings on precast floors can be particularly susceptible to severe cracking due to these effects.

Cracks of 10 mm width and more have been observed in shopping mall slabs incorporating precast floor units. The four questions one has to ask are, how much of the reinforcement crossing the joint remains unfractured, how can compression and shear be transferred as a result of this wide cracking, what is the strength of the diaphragm as a result of this wide cracking, and how does this affect the assumption of a ‘rigid’ diaphragm?

The issue of floor size and restraint is covered in many texts on reinforced concrete and prestressed concrete. Guides such those issued by The Institution of Structural Engineers and The Institution of Civil Engineers in Britain recommend that any large reinforced concrete building be ‘broken up’ with complete movement joints at maximum 50 m centres. Each part of the building between these joints must act as a completely independent, stable structure.

A very careful assessment of creep, shrinkage and thermal effects should be made if it is intended to have a floor plate longer than 50 m, especially if a thin topping on precast floor units is involved.

It is essential to ensure that when all of the creep, shrinkage and temperature effects have occurred, and all of the cracks have formed, the expected ultimate limit state strength of the diaphragm and the building as a whole can still be developed.

### **Drag and Collector Beams**

In many instances, the length of diaphragm in direct contact

with a shear wall or braced bay will be insufficient to transmit the diaphragm forces that the wall or brace must resist. This is particularly true in transfer diaphragms, although in this instance, the most intense force transfer can often be in the opposite direction - from the wall or brace to the diaphragm.

The most practical solution to this problem is to ensure that beams are aligned with and connected to the shear wall or braced bay, and that these 'drag beams' or 'collector beams' extend far enough into the diaphragm to allow proper load transfer.

Figure 12 shows how the diaphragm shown in Figure 4 can be improved through the addition of drag beams, provided the shear wall webs are thick enough to accommodate the drag reinforcement, and not buckle due to the lack of floor restraint.

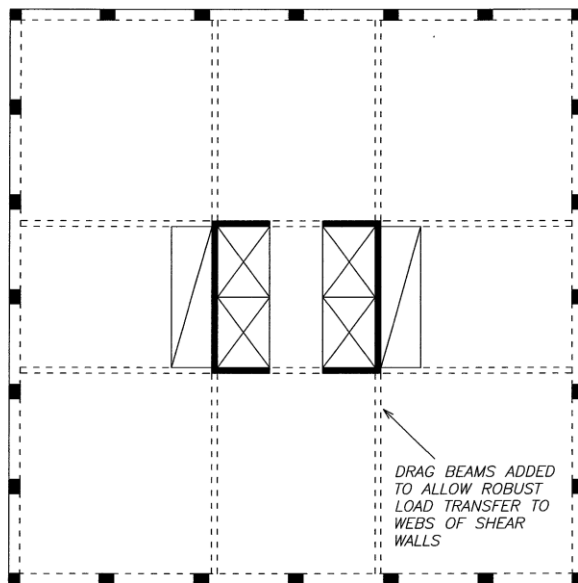

**Figure 12: Diaphragm improvement using internal drag beams.**

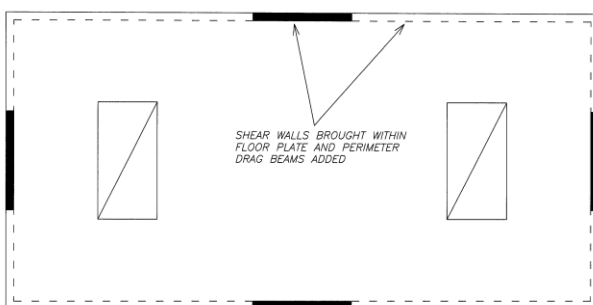

**Figure 13: Diaphragm improvement using perimeter drag beams.**

Figure 13 shows how the diaphragm shown in Figure 7 can be improved by bringing the walls within the floor plate, and adding drag beams.

For light loads, 'drag bar' reinforcement extending into the slab may be sufficient.

Invariably, there is an eccentricity between the diaphragm slab and the centre of the concrete or steel beam that is required to act as a drag beam (or diaphragm chord or stiffener), and the effect of this eccentricity must be considered by the design engineer. Usually, the length over which the force transfer from the diaphragm slab to the beam occurs is sufficient for

the resulting bending moments and shears to be small, but there may be instances where the force transfer occurs over short lengths of beam, and very large bending moments and shears will result. These effects must not be ignored.

Steel collector beams attached to steel braced bays must have sufficient composite slab concrete on both sides, or properly detailed confining steel to ensure the shear studs can transmit the loads from the slab into the beam. For all but the lightest loads, end moment connections should be used for steel collector beams in steel frames, so that the large axial strength of the two flanges can be utilised.

Web side plate ('WP,' or shear cleat) end connections to beams have limited axial strength in tension, and the eccentric nature of the connection, with the web side plate offset from the beam web, must not be ignored when designing a WP to transmit axial load in compression.

### Shear Wall Thickness

In good seismic resistant reinforced concrete design, the size of members must be determined not just by the strength and stiffness requirements for each individual member, but also by the requirement to ensure that the members, and in particular, all of the reinforcing bars, will fit together properly at the joints, without the mindless cranking of reinforcing bars in regions of high stress that so often occurs.

In many instances, openings in the floor adjacent to the web or flange of a shear wall mean that lateral restraint from the floor slab, as usually assumed by various concrete design standards, does not exist, and the engineer must ensure that the web or flange will be stable through other means, and that the real slenderness effects in the web or flange are accounted for.

Singly reinforced shear walls may be up to 200 mm thick. The author's opinion is that singly reinforced seismic resistant shear walls should be limited to low rise buildings, and if the walls are critical to the stability of the building, they should be stocky, not slender.

It is also the author's opinion that shear walls that are 250 mm thick are impractical - by the time cover and the finite size of the bars are considered, there is little gap between the two layers of reinforcement.

Wyllie *et al* [15] insist that for diagonally coupled shear walls, the minimum thickness of wall should be at least 16 inches (406 mm), with an absolute minimum of 14 inches (356 mm), in order to accommodate realistic pairs of diagonal coupling reinforcement that can fit past each other, and two lots of cover concrete, and two vertical and two horizontal layers of reinforcement in the walls.

The author agrees with this advice, and suggests that similar minimum wall thicknesses are required if the reinforcing bars from properly configured drag beams are to be accommodated in uncoupled shear walls. Furthermore, walls with two layers of reinforcement should have cross ties at close centres along their length, not just for confinement and improved axial load performance, but to prevent splitting of the wall that has been observed in some earthquakes.

### Coupling of Walls and Braced Bays by the Slab

One aspect of slab behaviour that is often overlooked is the tendency of *in-situ* and precast slabs to 'couple' closely spaced shear walls or braced bays. As a wall or braced bay deflects and rotates, one end goes up and one end goes down at each floor level, distorting the slab. If two shear walls or braced bays are close together, these distortions can generate significant coupling moments and shears in the slab, causing significant damage and an increase in the overall overstrength of the system until that significant damage occurs, an

overstrength that can be difficult to determine accurately.

### **Ductile Reinforcement and the Dynamic Fracturing of Reinforcing Bars**

The traditional low ductility welded wire mesh used in the topping of floors with precast concrete units or in composite metal deck floors performed poorly in the Christchurch earthquakes. Fracture of the mesh was noted in many buildings.

In the Christchurch earthquakes, unexpected fracturing of the ductile main longitudinal reinforcement was observed in numerous beams, columns and shear walls. Concrete strengths much higher than specified, combined with additional dynamic strength enhancement due to the high rates of strain loading, caused cracking patterns significantly different to those that usually occur in standard low speed university type tests. In these tests, numerous smaller cracks form in the hinge zones, and there is significant bond breakdown over long bar lengths, allowing the reinforcing bars to stretch without fracture. However, what was observed in Christchurch was a small number of wide cracks, with very limited bond breakdown. As a consequence, the strain in the reinforcing bars became excessive, leading to bar fracture.

In the author's opinion, diaphragm slab reinforcement should be ductile deformed reinforcing bars, detailed and handled to ensure that re-bending on site does not occur. The same applies for all starter bars from walls and frames into the diaphragm slab.

The diaphragm slab reinforcement must be firmly supported in position to the correct height, seated on approved concrete spacers, not plastic, so that the reinforcement can support the weight of the workmen and other loads during concrete placement and compaction and remain at the correct height. The use of deformed bars instead of mesh often allows a 300mm spacing of bars, which allows workmen to place their feet between the bars. 'Lifting' of unsupported reinforcement as the concrete is placed is not acceptable. For cast *in-situ* slabs with two layers of reinforcement, ensure that steel support chairs to support the top layer in position are shown on the drawings, and are supplied and installed.

The author's experience with *in-situ* slabs containing two layers of reinforcement is that if the steel support chairs are shown on the drawings, they are supplied and installed, but otherwise they are not. It is usually sufficient to show one chair diagrammatically on one detail only, with a reference to a suitable note. Just referring to support chairs in the specification is not sufficient.

In areas of the diaphragm such as drag beams where significant strains may develop and the load path must be maintained, care should be taken to ensure that dynamic fracturing of the reinforcing bars will not occur. Expert advice should be sought, and localised de-bonding of deformed reinforcing bars, or the selected use of plain reinforcing bars anchored with 180° hooks at both ends, may be necessary.

### **What Part of a Floor Forms the Diaphragm?**

With an *in-situ* slab, the full slab thickness can usually take part in diaphragm action. Especially when there are two layers of reinforcement, the layout and curtailment of reinforcing bars must suit the diaphragm requirements as much as the bending requirements due to gravity loading. Ideally, two uniform layers top and bottom would provide the diaphragm tensile strength, with supplementary reinforcement placed to resist any additional gravity load demands.

For precast floors incorporating rib, double tee and flat slab precast components, only the topping concrete will act as a

diaphragm, unless special details are used to tie the double tee flanges or flat slabs together.

For hollowcore units, with concrete filling the keys between the units (this must be ensured), the effective thickness of the diaphragm slab can be considered to be the topping thickness plus the thickness of hollowcore concrete above the voids.

The stresses in any thin topping acting as a diaphragm must be checked against limitations in the relevant code or standard, including requirements for ties between the topping and the precast floor units.

In general, for concrete filled metal decking composite floor slabs, the section of concrete above the metal decking units should be taken to be the effective thickness. Any attempt to utilise the strength of the decking, either in tension or in shear, must be done on a rational basis bearing in mind that the decking sheets are finite in size, and end connections to the decking sheets can develop only a small fraction of the decking strength.

Axial force components in the diaphragm can also be resisted and transmitted by properly designed and detailed reinforced concrete beams and steel beams acting compositely with the diaphragm slab. Full account must be taken of the eccentricity between the diaphragm slab and the beam, *by rational calculation*, not *a priori* assumptions. As indicated above, a simple check may show that the length of beam over which the force transfer occurs is sufficient to keep the resulting bending moments and shears small. However, there may be instances where large forces are transferred over short lengths, and significant bending moments and shears will result.

Particular attention must be paid to areas of diaphragms where the thickness is at a minimum. In one transfer diaphragm in an apartment building damaged in a recent earthquake in NZ, the effective thickness of the diaphragm reduced significantly adjacent to the perimeter, to satisfy architectural requirements. This reduced section cracked significantly.

### **'Code' Provisions for Diaphragms**

Explicit code provisions for diaphragms in New Zealand are largely limited to Section 13 of NZS 3101:2006 [1]. The provisions are very general in nature, with the only specific requirements relating to tying the topping of precast floor units in Section 13.4, and only then if the diaphragm is considered to be acting in a 'ductile' or 'limited ductile' fashion.

Clearly, whilst diaphragms must be 'tough,' they should not be assumed to be forming plastic hinges. Diaphragms must only be designed to resist elastic ( $\mu=1$ ), nominally ductile ( $\mu=1.25$ ) or overstrength actions. However, the provisions of Section 13.4 should be applied to all diaphragms incorporating precast floor units where the diaphragm stresses are anything but minor.

Figure 14 of Bull's paper [3] and the related text shows one of the reasons for tying the topping to the precast floor units where the stresses are high. Even with nominally ductile response, the concrete will crack and the diaphragm reinforcement will yield due to tension in one cycle, and then go into compression on the next.

### **Should Seismic Diaphragm Component Forces be Combined with Forces from other Types of Action?**

Contrary to what is often expressed in other papers on diaphragms, the author considers that seismic diaphragm force components should not be considered in isolation, and must be combined with actions from other loads that must be acting simultaneously, for example, gravity loading and soil retaining loads.

The simple fact is that these actions occur at the same time, and if a slab requires a certain strength to support its self-weight and imposed gravity loads, and in some instances, axial loads from retained soil loads, it must require additional strength to resist additional imposed seismic forces.

### Buckling of Diaphragms

The potential buckling of diaphragms is often a complex problem, but should not be overlooked, especially when transfer or compatibility effects lead to very large force components.

Under non-seismic conditions, a slab in a buried podium structure subject to soil retaining forces may be subject to uniform axial load, in one or two directions. Gravity loads on the slab will cause vertical deflections, which will increase due to creep, and these P-delta effects will reduce the buckling resistance of the slab.

Most diaphragms above ground in NZ will consist of the topping on a precast floor slab, or the solid concrete above a profiled metal decking. In both instances, the relatively thin diaphragm will be completely dependent upon composite action with the precast floor units or the concrete filled metal decking to prevent buckling. This is another reason to ensure toppings are tied to precast floor units when the diaphragm actions are anything other than nominal.

It should not be assumed that the *in-situ* slab or composite precast or metal deck floor will not buckle – it should be checked by rational analysis. This is a complex problem, because the buckling will often be caused by diagonal compression force components, not overall uniform axial load, and P-delta effects due to the vertical deflection of the slab must be considered.

The potential buckling of beams near floor openings that are unrestrained by the floor but required to carry axial load must not be ignored.

### Detailing of Reinforcement

The general principles of developing and anchoring reinforcement apply to diaphragms. A conservative approach should be taken when terminating reinforcing bars.

Around the perimeter of a diaphragm, the outwards thrust of the inclined compression struts must be ‘tied’ back by the diaphragm reinforcement. Standard Strut and Tie practice requires the ends of the reinforcing bars to be hooked or be fitted with an end bearing plate to allow this force transfer to occur at the end of the bar.

The 90° or 180° bar hook must lie towards the inclined compression strut, for effective force transfer.

Under reversed seismic loading, however, the inclined compression struts will come from opposite sides of the bar.

Generally, 10 mm or 12 mm diaphragm bars will be anchored around the perimeter of a diaphragm by being lapped onto starter bars from walls or beams. These starter bars should project as close as possible to the outside face of the wall or beam, and be hooked down into the wall or beam.

Ideally, starter bars projecting from *in-situ* walls would be installed as straight bars, which are bent down on site after the flooring has been placed, so as to avoid re-bending on site, with all its attendant problems. Especially with the availability and affordability of the threaded Reidbar system, there is absolutely no valid reason whatsoever for the cold re-bending of any reinforcing on site whatsoever, even with precast shear wall panels.

Where 16 mm bars and larger are required to tie compression struts around the perimeter of a diaphragm, explicit checks of the end anchorage capability of the details under reversing seismic loading should be carried out. Bull [3] covers some of these details in depth.

Sometimes, one sees very large diameter bars, even 32 mm, specified in 65 mm thick toppings, to resist diaphragm ‘chord’ forces. This is highly suspect – there is a very real tendency for the large bar to buckle in compression, particularly after a couple of cycles of tension loading, not to mention violation of code provisions limiting the diameter of reinforcing bars relative to concrete thickness. A far better approach is to include an actual beam to act as the chord, complete with stirrups to prevent bar buckling.

### Proper Compaction of Concrete in Diaphragms

Far too often in NZ, the proper compaction of concrete on site is neglected, especially concrete that will be required to form a diaphragm. It is as if many of the people placing the concrete and supervising its placement view an immersion vibrator as a levelling or concrete movement device and nothing more, and they have no comprehension of the need for sound dense concrete to not only develop the required concrete strength, but also to provide durability and resistance to moisture transfer.

The proper use of an immersion vibrator on site should be one of the simplest tasks to be achieved, but it isn’t.

For *in-situ* work, all too often large ‘boney’ areas of uncompacted concrete are exposed upon removal of the formwork. Worse is the *in-situ* component on top of precast floor units or composite metal decking, where the screeded top surface and the stay in place underside prevent exposure of any uncompacted concrete.

In many of the photos showing the placing of topping on precast floor units and even composite metal decking one sees in industry journals, there are workmen, concrete pump hoses, rakes and screeds all present, but no one compacting the concrete with an immersion vibrator. And ‘self-compacting’ concrete is not being used.

Even when one can get the concrete in precast and composite slabs to be vibrated, there is a recurring problem with regard to screeding and the working face. As concrete trucks change over at the pump, screeding proceeds right to the edge of the placed concrete, even though the last several hundred millimetres width of concrete could not have been vibrated. But when one asks the workmen to compact that unvibrated concrete once the new concrete starts to be placed, they refuse, because it has already been screeded.

These practices have to stop. Unless self-compacting concrete is being used, all concrete that is placed on site must be fully compacted with immersion vibrators, and the placement, compaction and screeding must be done in a sensible staged manner so that there are no uncompacted zones, even if that means some re-screeding.

And, of course, all diaphragm concrete must be properly cured, especially given that diaphragm concrete is relatively thin, with a very large surface area to volume ratio.

### Steps in Diaphragms

Steps in diaphragms occasionally occur. Often, steps occur in the top floor of podium structures, due to the slope of the surrounding land, and architectural requirements. Such floors are often subject to very large transfer diaphragm forces, and the effect of steps must be properly accounted for.

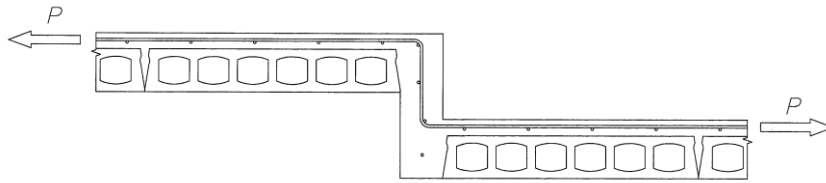

**Figure 14(a): Inadequate detailing of stepped diaphragm.**

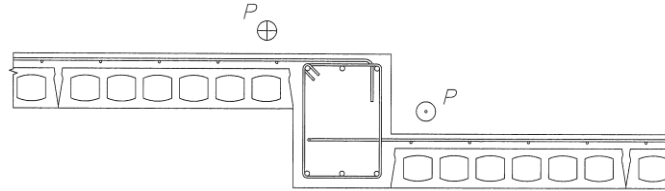

**Figure 14(b): Stepped diaphragm - force transfer along step.**

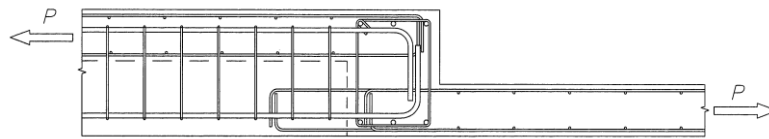

**Figure 14(c): Stepped diaphragm - force transfer across step.**

Figure 14(a) shows the type of diaphragm step detail the author has seen proposed on more than one occasion. It is nonsensical, but ‘convenient.’ There is no way that any appreciable force, particularly a tension force, can be transmitted transverse to such a step, unless the diaphragm was extremely thick, and the corners of the step were able to be detailed as reliable opening/closing moment joints.

Figure 14(b) shows a detail which can be used to transfer forces parallel to the step, provided the beam forming the step is properly designed for the resultant actions and adequately supported by columns or walls.

Figure 14(c) shows the likely detailing required where forces transverse to a step must be transferred across it. Either side of the step, the slab is solid *in-situ*, and closely spaced beams are installed on the left hand side, to transmit the forces from the high slab to the low slab. Slab reinforcement from the lower slab is extended well into these beams, to allow for the proper (concentrated) tension load transfer. The eccentric load transfer generates a moment that must be resisted by the beams and slabs in accordance with their relative thickness. Again, the beams forming the step should be properly supported by columns or walls.

### Saw Cuts in Diaphragms

In shopping malls and car park buildings in particular, diaphragms, particularly those consisting of *in-situ* toppings on precast floor units, are often subject to all sorts of saw cuts in an attempt to ‘control’ cracking for non-structural purposes.

Why cut through a perfectly good structural element that has cost the client a lot of money to have had installed? If diaphragm toppings and slabs must be saw cut in such a manner, then their strength should be assessed on the thickness that is left *under* the saw cuts, *not* the initial gross thickness.

In the first instance, careful consideration must be given to the total size of the building and floor plates, taking into account shrinkage and thermal effects. Very large floor plates should be broken up into completely independent structures, with

appropriate sliding joints at the interface.

As with all structural concrete, the concrete used in diaphragms should have the minimum water and cement contents consistent with other material performance criteria, to ensure shrinkage is minimised. Consider the use of Denka or Onoda expansion agents. Diaphragm concrete must be fully compacted, and well cured. Use superplasticizers to achieve workability, not water.

### Giving Diaphragms the Attention They Deserve

To reiterate, floor diaphragms are a critical component of all buildings subjected to seismic loading. Often, the derivation of the loads they are subject to is difficult, and their proper analysis and design can be extremely complex and difficult.

Diaphragms must have design time and resources allocated to them sufficient to deal with the real complexities they present, and diaphragms must be treated with the same respect that we demand is paid to the main frames, walls and bracing of a building.

The author has seen one large complex diaphragm, which contained numerous steps, large openings and complex load paths ‘designed’ by another engineer in less than two hours. The ‘design’ consisted of a small increase in topping thickness and mesh size. In reality, to have properly and rigorously analysed and detailed that diaphragm would have taken weeks, and may well have required significant changes to the structure.

Fees and programmes will have to expand to allow for the proper analysis and design of all diaphragms in a building.

If clients, architects and project managers don’t want this expenditure of time and money, then they will have to conceive of extremely simple buildings, with repetitive floor diaphragms and lateral load resisting elements throughout their height.

## ANALYTICAL METHODS

### Simple Hand Methods

Simple methods treating a floor diaphragm as a simply supported beam or cantilever are only applicable for the most simple of diaphragms (rectangles) and support conditions, with very small openings placed in locations where they have very little effect on the strength of the diaphragm.

### Conventional Strut & Tie Analysis

The conventional, rigorous Strut & Tie (S&T) method can be applied to analyse complex diaphragms subject to inertial and transfer forces. However, the S&T method cannot automatically identify the compatibility forces that may exist in a slab on its own – a separate 3D building analysis is required, and if this analytical model incorporates rigid diaphragms, significant over-estimates of the compatibility forces can occur.

Whereas the S&T method can be used to arrive at a safe design for even very complex diaphragms, it usually requires a great deal of effort, and *every load case* for one diaphragm requires *its own unique S&T model*.

The more complex a diaphragm becomes, the more difficult it is to arrive at these unique models, and in many instances, an initial linear finite element analysis should be done using a suitable program to identify an appropriate layout of struts and ties based on the principal stress components. In addition, if the support conditions change to accommodate changes to the location of walls or braces, or simply to make the diaphragm ‘work’ as part of the design process, completely new models must be developed and analysed, one for each load case, whereas the Truss Method proposed in this paper requires only one model that can be quickly modified and re-run, for all load cases.

The relatively large spacing of nodes used in most conventional S&T models usually results in highly concentrated points of load transfer to the reinforcing steel in areas of solid continuous slab, whereas, in reality, the load transfer is much more distributed.

The Truss Method described below can be used to model every floor diaphragm in the 3D analytical model of a tall building in which compatibility effects are likely to be significant. The conventional S&T method cannot be incorporated into a 3D model. Compatibility effects will be accounted for by the conventional S&T method if a separate 3D model of the building is developed and analysed, with the forces transferred in and out of lateral load resisting elements then used as input into an S&T model for each significant floor. However, in buildings where compatibility effects are likely to be significant, studies by the author indicate that if rigid diaphragms are assumed in this separate 3D model, the maximum compatibility effects may be over-estimated by 50%. Although that would generally be conservative, it may make the detailing of the diaphragm at the most heavily loaded floors difficult or even impractical.

### Non-linear Finite Element Methods

Normal finite element analyses using linear elastic triangular and rectangular finite elements can be used to model the geometry and stiffness of a diaphragm. However, deriving useful design information on the internal forces acting within the diaphragm from such analyses is problematic, at best.

Advanced non-linear finite element programs may allow some useful information on the internal forces to be derived, but these programs are very expensive, difficult to use for all but experienced operators, and require significant processing

resources and time for each analysis, along with considerable post-processing time.

One of the most useful suites of non-linear programs for the analysis and design of floor diaphragms appears to be Ruaumoko [16, 17].

For her PhD studies into seismic forces acting on diaphragms, Gardiner [18] used lattice elements in Ruaumoko as one analytical tool. She used concrete and steel lattice elements in parallel to model the non-linear behaviour of reinforced concrete diaphragms.

### The Truss Method

The Truss Method is essentially a linear finite element method of analysis that uses simple truss elements instead of triangular or rectangular elements, and is at the same time a type of strut and tie analysis. As such, it complies with requirements in NZS3101: 2006 [1] to use strut and tie models for the analysis and design of certain aspects of diaphragm behaviour. It can be implemented on any basic structural analysis package such as Microstran [19] or SpaceGass [20] which incorporates compression-only elements.

The method allows simple analyses similar to the more complex analyses that can be done on Ruaumoko [16] using lattice elements.

Just as, with care, a two way slab can be analysed under gravity loads as an equivalent grillage of beams, each representing a tributary width of slab, the Truss Method allows a diaphragm to be analysed for in-plane loads by treating it as an orthogonal grillage of truss elements, each representing a tributary width of slab, with compression-only pairs of diagonals throughout the grillage to allow for diagonal strut action. It is assumed that the reinforcement in the diaphragm is placed orthogonally.

The refinement of the truss is a matter of judgement – fine enough to allow the diaphragm geometry and behaviour to be effectively modelled, but not so fine as to produce an overwhelming amount of output data.

Supports for 2D truss diaphragms can be modelled in two ways, depending on the circumstances. In general, all the supports in a 2D truss model should not be ‘rigid,’ because the load distribution to the supports and the internal truss forces will be inaccurate.

For the single level diaphragm example springs were used to conveniently model the stiffness of the cantilever shear walls below that provide lateral support. If a 2D truss is being used to analyse a diaphragm in a multi-level building that has been analysed independently using a separate 3D model (a model that usually includes infinitely rigid diaphragms), spring supports can be used to support the diaphragm. At any level, the seismic force transferred by the diaphragm to (and in some cases from) each supporting wall/brace/frame equals the *vector* difference between the shears in the wall/brace/frame above and below the diaphragm. (Beware of situations, such as with transfer diaphragms, where the shears change direction, and hence the vector sum means the two shears add together). The stiffness of the spring supports can be adjusted so that the force transfer to each wall/brace/frame support matches that in the 3D model.

Alternatively, ‘reactions’ from each wall/brace/frame can be used as ‘supports’ to the diaphragm, using the simple method described in Appendix A.

Trusses can be included in 3D models to represent all of the floor diaphragms.

Multiple load cases can be handled by the one model, unlike the conventional S&T method. Provided changes to geometry

or support conditions do not require a redefinition of the main grillage, modifications to the model can be made and quickly re-analysed, unlike the conventional S&T method.

For each load case, the location of ‘struts’ and ‘ties’ is automatically determined by the analysis, based on the requirements for equilibrium. Drag beam requirements are clearly indicated, and forces around openings and at re-entrant corners are automatically produced, and the analysis indicates how far those actions must be developed past the opening or corner.

Because most floor diaphragms are flat, the truss model will be ‘flat,’ and two dimensional. However, complex diaphragms that incorporate steps, and are hence three dimensional, can be modelled through the addition of beam elements and rigid links to model the steps.

Openings and re-entrant corners are automatically accounted for in the geometry. If parts of the diaphragm are likely to be ineffectual because of damage caused by plastic hinge growth in reinforced concrete beams or other precast floor damage, truss elements in those areas can be removed.

The Truss Method handles highly concentrated force transfer around openings and at re-entrant corners like the conventional S&T method, but where there are large areas of slab, the Truss Method allows for much more distributed force transfer, approximating continuous shear flow, providing the grillage is fine enough.

With the Truss Method, the design procedure for the diaphragm is similar to the S&T method. The shear strength,  $v_c$ , is taken to be zero, and all actions, including shears, are resisted by strut and tie action.

This method is not, of course, merely confined to diaphragms, and can be used, with caution, to analysis complex beams and walls that are more often analysed using S&T methods. At the very least, it can be used to determine the location of the struts and ties, before carrying out a more rigorous S&T analysis.

The Truss Method is described in detail in the following main section.

### **A Single Floor Model, or Multiple Levels?**

In most instances, the floor diaphragm is offset to the top of the supporting beams that form part of the lateral load resisting system. Therefore, part of the diaphragm will act as a flange to the beams. For the sake of simplicity in this paper, it is assumed that any ‘flange effects’ and secondary moments in the beams due to diaphragm actions will be considered separately, and the beams and diaphragm members can be assumed to lie in the same plane. Rigid offsets can be used to model this offset between the diaphragm and the beam centrelines, but this is a significant complication.

One significant advantage of the Truss Method is that it can be incorporated directly into a full 3D model of the building as a whole, with trusses at each floor level that will automatically account for all forces and compatibility effects acting on the diaphragms.

For a building with a single diaphragm level, in lieu of a 3D model of the building incorporating the diaphragm, springs representing the stiffness of the lateral load resisting elements can be used as the supports to the 2D diaphragm truss model.

For any 2D diaphragm truss model, rigid supports should not be used, because in general, an inaccurate distribution of reactions and hence diaphragm actions will result.

For buildings with multiple floors, and in which compatibility effects are negligible, each floor can be modelled as an isolated diaphragm. It is difficult to calculate directly the

actual stiffness that each floor will ‘feel’ from the lateral load resisting elements. It is suggested that as a starting point, the stiffness of the spring supports should be calculated as if this floor was a single storey, with the floor below as ground level, and then the stiffness should be ‘tuned’ so that the reactions match the forces entering the lateral load resisting elements at that level, as indicated by the overall 3D building model.

For buildings in which compatibility effects are likely to be significant, the author recommends creating a 3D model of the building that incorporates trusses at each floor level to represent the diaphragms, despite the effort involved.

Once the model is created, all load cases can be handled with the single model, and all compatibility effects are automatically and accurately accounted for.

Otherwise, each floor (or representative floor for a group) must be analysed separately, for each separate load case. Forces representing the ‘reactions’ from each lateral load resisting element at each floor level within the separate 3D model of the building must be extracted, and used as input for each conventional S&T model for each load case.

As stated above, if the separate 3D model incorporates rigid diaphragms, compatibility effects can be significantly overestimated. Studies on a 30 storey building with shear wall core and perimeter frame carried out by the author show that infinitely rigid diaphragms increase the very significant compatibility effects at the top floor by 50%, over those obtained using very rigid trusses to model the finite floor stiffness.

## **THE TRUSS METHOD FOR THE ANALYSIS AND DESIGN OF DIAPHRAGMS**

### **The Truss Method**

The Truss Method is best described by way of example.

Consider a fixed base, cantilever reinforced concrete shear wall. This simple wall is considered in the first instance, because it allows a check of the accuracy of the method with regard to deflections, and internal force distribution.

The wall height is 9.25 m, the length 3 m and the thickness 300 mm (Figure 15). Load cases consist of one 1000 kN point load pushing against the left hand side of the wall, at a height of 9 m (Unit Load A), and one 1000 kN point load pulling from the right hand side of the wall, at a height of 9 m (Unit Load B).

To create the 2D truss model in Microstran [19], the wall was ‘cut’ into a series of 500 mm strips horizontally and vertically. Truss elements were placed between node points at the intersections of the centrelines of these strips. Pairs of compression-only diagonals were then added to every bay of the grillage. All base nodes were restrained with rigid supports in the horizontal and vertical directions.

Truss elements capable of resisting axial loads only were used in this example. Pin ended beam elements can also be used, but ensure at every free node that the end of one member meeting at the node is not pinned, to avoid local instability.

For this exercise, gross sections were considered, with Young’s Modulus  $E_c = 2.7 \times 10^7$  kN/m<sup>2</sup>, and Poisson’s Ratio,  $\nu = 0.2$ . The horizontal and vertical truss element properties were those for a 500 mm wide by 300 mm thick rectangle. The diagonal dimension (or inclined width) of each bay in the grillage is  $500\sqrt{2} = 707$  mm. (Refer following paragraph). Assigning 75% of this dimension as tributary to each diagonal leads to the properties of each diagonal element being those for a 530 mm wide by 300 mm thick rectangle.

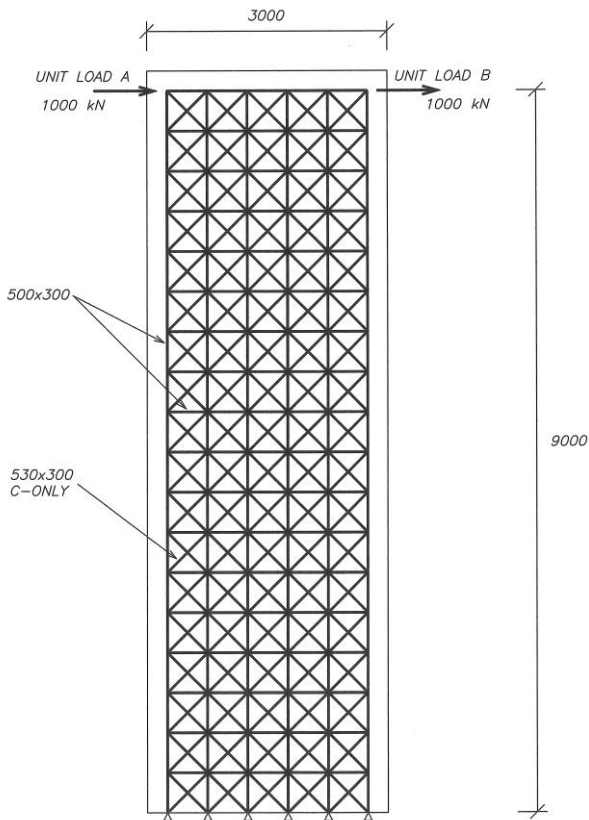

Figure 15: Shear wall test of truss method.

For the Truss Method, the size of the grillage is a matter of judgement. Fine enough to allow the geometry to be accurately modelled, and realistic internal structural actions to occur. Experience in comparing Truss Method deflections with ‘exact’ solutions such as in this example, or with finite element analyses, indicates that until further studies indicate otherwise, for an ‘uncracked’ diaphragm the rectilinear truss elements should have the full tributary width assigned to them, and compression-only diagonals should have 75% of the ‘inclined’ width assigned to them.

The theoretical horizontal deflection of this cantilever wall at the height of the loads, taking into account flexural and shear deformations, is 14.4 mm. The deflection for the truss model was 14.8 mm, which was in good agreement.

Figures 16 and 17 show the truss member forces at the top of the wall for Unit Loads A & B respectively. Tension forces are positive, compression forces are negative. The ‘struts’ and ‘ties’ automatically adjust for each load case. Figure 18 shows the truss member forces at the base of the wall for Unit Load A, and the corresponding forces were almost identical for Unit Load B.

The distribution of forces is consistent with conventional reinforced concrete beam theory and design, assuming the shear strength of the concrete,  $v_c$ , equals zero.

The quantity of reinforcement required for each orthogonal tie is simply the tensile axial force divided by the yield stress of the reinforcement reduced by the capacity reduction factor, and this reinforcement can be distributed across the depth of the truss member. Simple checks as to the rate at which the tension force is increasing along a strip, and whether major loads are introduced at discrete points, can readily be done to determine if the bond stress is likely to be exceeded, and if so, more detailed nodal checks as per the S&T method can be carried out.

The concrete stresses for both the orthogonal and diagonal struts can be easily derived, and checked against the allowable, including allowance for slenderness and buckling if required. If the stresses are high, the interaction of the components of orthogonal and diagonal compression stress may need to be checked.

For this particular example, the tie forces at the base and the magnitude of the concrete stresses indicate that the wall thickness should be increased, or column boundary elements introduced at each end.

**Comparison with Strut and Tie Examples**

The Truss Method was tested against several S&T models presented by Reineck [21].

For a cantilever shear wall with two openings, subjected to five load cases involving various combinations of vertical and horizontal point loads, reasonable agreement in the strut and tie forces for each load case was achieved. Whereas the S&T method required five complex models to be developed, the Truss Method required only one model. A major difference in the results between the Truss Method and the S&T method was that clear of openings, the Truss Method showed a realistic, near uniform shear flow in the outer vertical members, instead of highly discrete zones of force transfer.

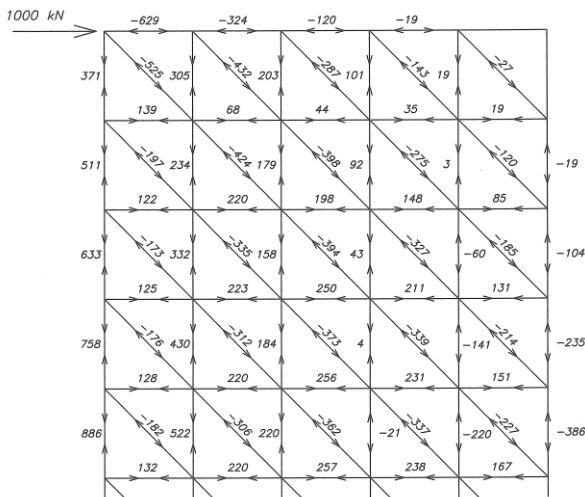

Figure 16: S&T forces at top of shear wall - unit load A.

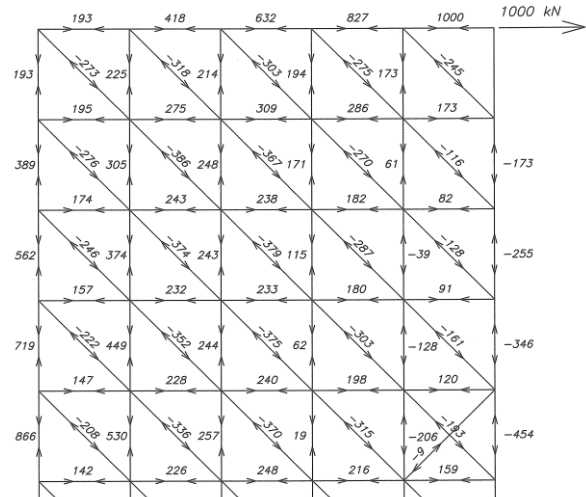

Figure 17: S&T forces at top of shear wall - unit load B.



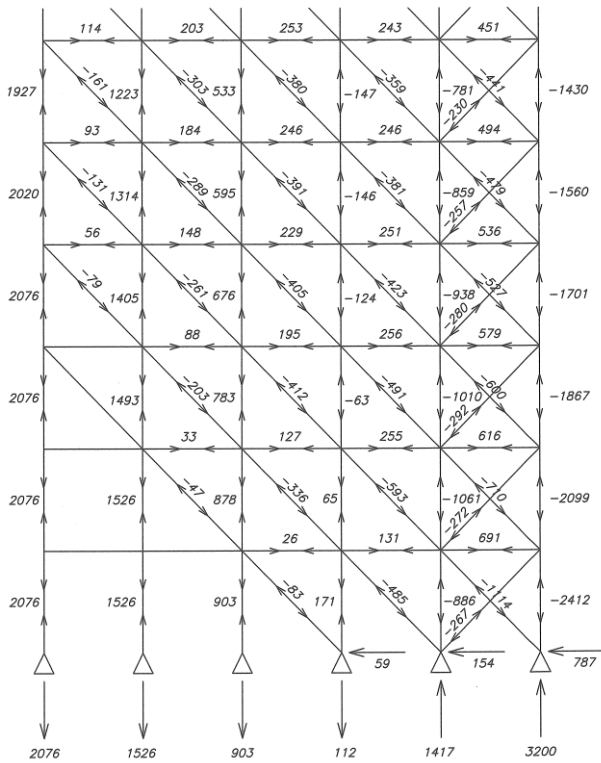

Figure 18: S&T forces at the wall base - unit loads A & B.

For a deep beam with one large opening and a reduced section at one end, and subject to a single vertical point load over the opening, the reactions were, of course, the same for both methods, but the distribution of internal forces was significantly different. The author believes the Truss Method produced the more accurate distribution. The S&T method assumed the point load over the opening was resisted by two opposing diagonal struts, tied just above the opening, whereas the Truss Method showed diagonal struts, plus significant negative bending moments as the concrete beside and above the opening was able to act like a deep portal frame.

**Diaphragm Example**

Figure 19 shows the plan view of a suspended reinforced concrete First Floor in a theoretical two storey retail building. A steel structure forms the upper walls and roof, and the weight of this was assumed lumped at the First Floor level as an additional superimposed dead load (SDL) for the analysis and design of the diaphragm.

The location is Auckland, with Site Subsoil Class C, and  $\mu=1.25$  for the main structure and the diaphragm. The first period,  $T_1$ , was assumed to be 0.1 seconds. The floor consists of a cast *in-situ* reinforced concrete ribbed slab, spanning one way between beams. This would be constructed efficiently using modern formwork systems and a skilled workforce. Four reinforced concrete shear walls are assumed to provide all the lateral load resistance.

At the re-entrant corner, a 'stiffener' beam running parallel with the floor system has been introduced, to ensure the corner is strengthened in both directions.

There are three large floor penetrations. One of these is adjacent to the left hand shear wall. This affects not only the load transfer from the diaphragm to the wall, but also compromises the stability of the wall. As a consequence, two 1200x400 return flanges have been introduced to stiffen the ends of the wall out of plane. Slenderness effects in the wall will be checked in the horizontal direction. These return flanges were ignored in the analysis, however, because it was assumed that the squat nature of the walls, and the effect of shear deformations and foundation flexibility on the stiffness of the walls meant that the actual impact of the flanges on overall force distribution would be negligible.

The floor penetration adjacent to one of the perimeter beams mean that the slenderness of that beam would have to be checked, especially when subjected to compressive diaphragm 'chord' actions.

In reality, the 400x400 columns shown are probably too small for a sound, seismic resistant design. Consistent with good Californian design, a structure such as this, where shear walls are used to resist 100% of the code specified seismic loads, should still be able to develop sufficient frame action so that if the shear walls were removed, the frames can resist 25% of the code specified seismic loads.

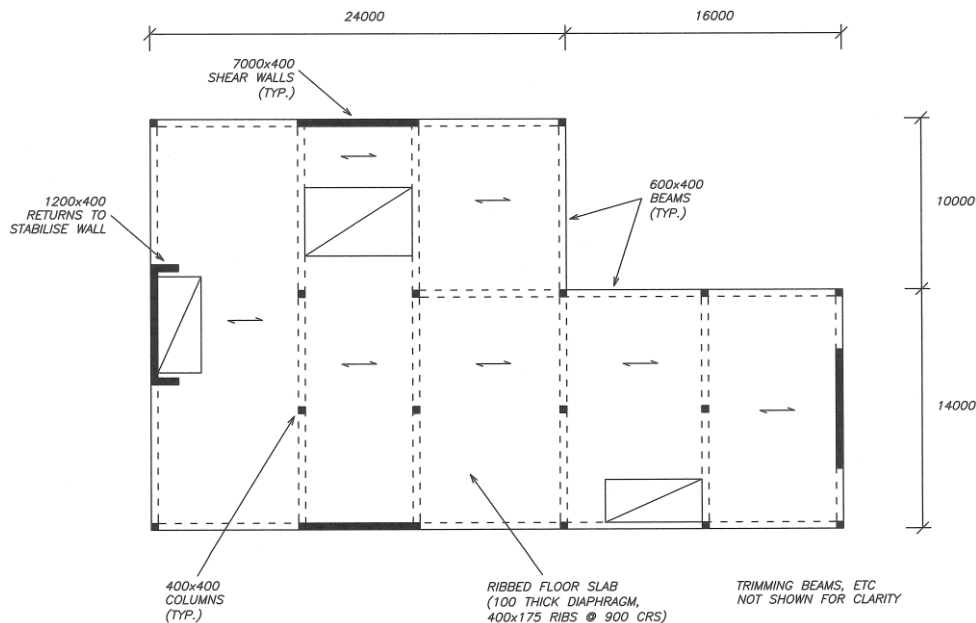

Figure 19: Diaphragm example – geometry.

Figure 20 shows the proposed truss model laid over the actual geometry. The ribs of the floor system have been ignored in the assignment of member properties, and for the purposes of this exercise, the number of different section sizes has been minimised. For the analysis of a real building diaphragm, more section types should be used for greater accuracy.

Figure 21 shows the 2D truss layout alone. Multiple springs are used to represent each shear wall, the spring stiffness having been easily derived for a cantilever shear wall, adjusted to allow for shear deformations and foundation flexibility.

The total seismic weight tributary to the First Floor was calculated, based on the weight of the main reinforced concrete structure, an SDL of 0.75 kPa to represent the steel structure above, an SDL of 0.75 kPa for the First Floor, and a live load contribution of 0.6 kPa (being derived from a design live load of 4.0 kPa).

The horizontal design action (base shear) coefficient for this 'one mass level building' ( $C_d(T_1)$ ) equals 0.27, whereas  $C_{dia}$  derived by the Cowie *et al* method was 0.25. The 0.27 value was used as the seismic coefficient for this analysis.

Because this is essentially an elastic building and overstrength actions are not being applied, +/- 0.1b eccentricities of seismic loading should be applied. For that, a minimum of eight load cases would be required, to account for earthquakes acting in both plus and minus principal directions as well as the eccentricities. Numerous additional load cases would be required to account for the requirement of 100% actions for one principal direction combined with 30% actions for the other principal direction, because of the elastic/nominal ductile response.

To reduce these to four load cases with the resultant acting through the centre of mass (E+X, E-X, E+Y, E-Y), the seismic forces were scaled up to account for the eccentricities and 100% + 30% requirement.

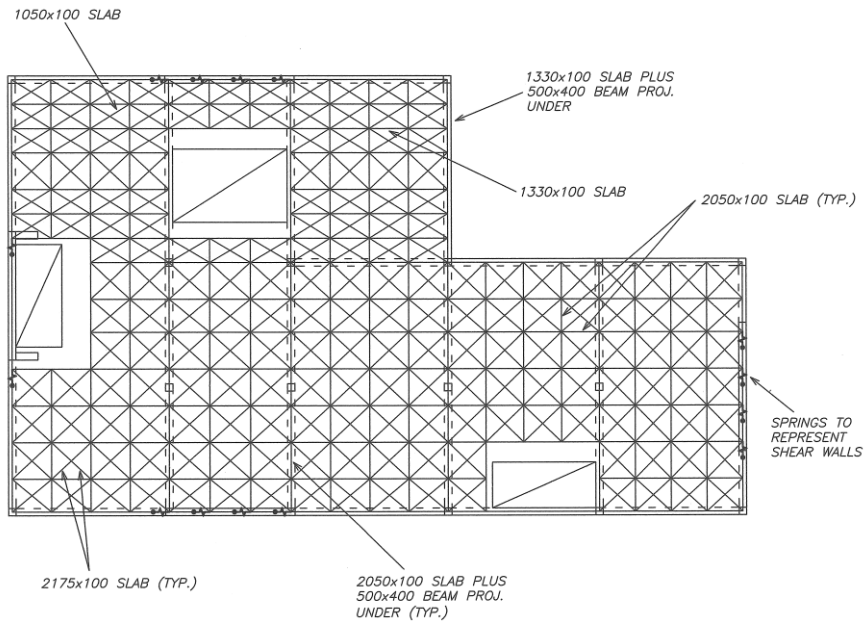

Figure 20: Diaphragm example - truss overlaid on geometry.

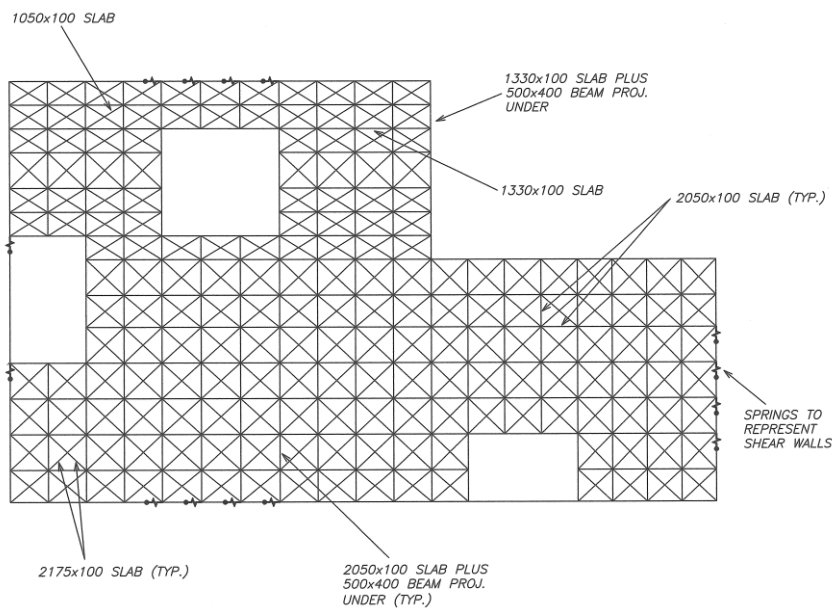

Figure 21: Diaphragm example - truss model with spring supports.

Because there are two shear walls in each direction, and these walls are located at the extremities, a 20% increase in base shear should cover the +/- 0.1b eccentricity requirement, and from experience, a 10% increase should cover the 100% + 30% requirement. These should be checked in more detail for the actual analysis of a real building.

The seismic weight is 6770 kN. The scaling factors and seismic design coefficient combine to produce a total seismic load on the diaphragm for each direction of  $E_u = 1.20 \times 1.10 \times 0.27 \times 6770 = 2413 \text{ kN}$ .

This was distributed to each node point of the truss, based on approximate tributary areas to each node. Again, this was a simplifying assumption for this example. For a real diaphragm analysis, a more accurate distribution of loads based on the tributary mass to each node should be made.

An interesting problem developed when the model was initially run. Previously, models derived using the Truss Method had always run and converged.

For this particular example, the iterative 'non-linear' analysis required because of the presence of the compression-only diagonals would not converge in the first instance. However, solution was achieved by adjusting the Displacement Control in the Non-Linear Analysis Parameters one 'notch' above minimum.

In most instances, even for highly irregular diaphragms with numerous openings and spring supports, non-linear convergence will be achieved without any adjustments to these non-linear analysis parameters, other than perhaps excluding P-Δ and P-δ effects. Should adjustments to the non-linear convergence controls be required, refer to the recommendations in the relevant software user manual, and then check the output for signs of ill-conditioning of the stiffness matrices, and inaccuracies in the reactions, which is advice that actually applies for all non-linear analyses.

Figure 22 shows the truss forces for the load case E+Y in the right hand part of the diaphragm, with the seismic load in the positive Y direction. Figure 23 is for the load case E-Y, with the seismic load in the negative Y direction. The four reactions combined represent the horizontal force into the shear wall.

These forces can readily be used to design the required diaphragm reinforcement, and check the compression stresses in the diaphragm. Major 'chord' forces can be seen, and it can clearly be seen how the loads onto the right hand shear wall are 'collected' by the beam projecting from both ends of the wall, as well as being introduced directly into the wall itself.

**Practical Considerations in Modelling a Diaphragm as a Truss**

Just as with the S&T method, the diagonal members must not be 'too flat' or 'too steep.' If so, dependable strut action cannot be relied upon. Consistent with the NZS3101:2006 [1] provisions for the S&T method, the diagonals must not be closer than 25° to the horizontals or verticals, and the closer to 45° the better.

When modelling a 'flat diaphragm,' the truss model should be purely 2D, and all of the truss members should, in general, be fully pinned truss elements, subject to no bending moments or shears, and with no moment transfer at the joints.

The programs most likely to be used to analyse a diaphragm truss model in NZ at present are Microstran [19] and SpaceGass [20]. For a model incorporating compression-only members, an iterative non-linear analysis will have to be performed. These usually incorporate 'P-Delta' and 'P-delta' effects. The P-Delta effect accounts for the additional actions due to displacement of the nodes of the structure. The P-delta effect accounts for the second order effects due to lateral displacement of the members between the nodes, with bending moments increasing in the presence of axial compression, and reducing with the presence of axial tension. If members are too slender with respect to the applied loads, they will become unstable within the analysis itself.

If the axial compression in a truss member exceeds the Euler buckling load, the member will become unstable during the analysis.

In a real precast concrete or composite metal deck diaphragm, the concrete thickness acting as the diaphragm cannot buckle in plane because of its continuity, and, subject to proper design, will not buckle out of plane because of the flexural stiffness of the precast floor units or the composite steel slab.

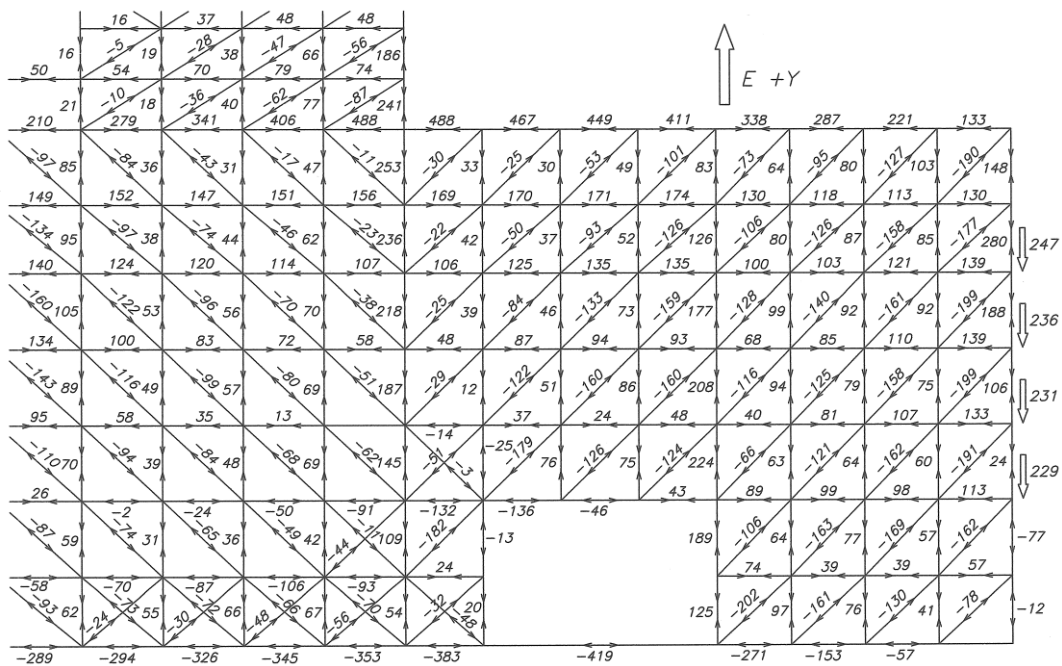

Figure 22: Diaphragm example - S&T forces at RHS - load case E+Y.

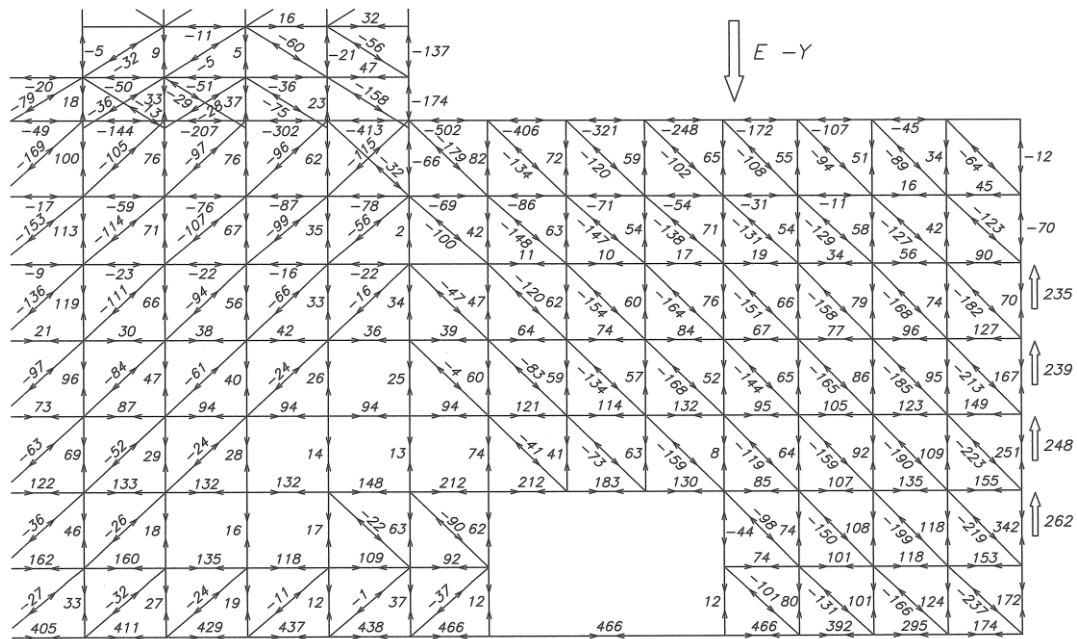

Figure 23: Diaphragm example - S&T forces at RHS - load case E-Y.

For a 2D truss model, once the diaphragm is ‘cut up’ into discrete truss members, buckling of the truss members in the non-linear iterative analysis should not be a problem, provided the properties of the truss members are correctly oriented, with their ‘wide’ dimension in plane, and their ‘thin’ dimension out of plane.

Alternatively, the second moments of area of the various truss members could be arbitrarily increased to ensure buckling cannot occur in the model.

For a 3D truss model used to model a stepped diaphragm, with the vertical support from walls and columns accurately included, the truss members will, in general, have to have their second moment of area for the out of plane direction increased to prevent buckling.

In general, the truss model will incorporate gross section properties, or if the engineer so desires, some uniform reduction in gross properties to allow for some cracking. This ‘uniform’ approach to cracking and section properties is consistent with most reinforced concrete analysis, and not dissimilar to the S&T method.

However, some engineers may wish to allow for greater cracking of those truss members subject to the greatest tension forces. For a typical model with multiple load cases, trying to iterate by hand is impractical. Therefore, consideration should be given to using a non-linear finite element analysis program such as SAP 2000 Advanced [22] or ETABS Ultimate [11], which can allow for a more complex, non-linear definition of material and section properties, including cracking under tensile load. Such analyses should only be carried out by engineers suitably trained and experienced in using these non-linear features, and the work must be properly checked.

## CONCLUSIONS

As an alternative to the conventional Strut and Tie method for the analysis and design of diaphragms, the author has developed a Truss Method which allows complex diaphragms to be modelled and analysed in an efficient manner consistent with common design office methods. The diaphragm is modelled as a single truss, typically with multiple bays in both principal directions, and this single model can handle multiple load cases. This method effectively constitutes a type of linear finite element analysis using truss elements, and is also a type

of strut and tie analysis. The analysis automatically determines the struts and ties for each load case. The results of the analysis are in a form that can readily be used to design the diaphragm elements.

Floor diaphragms form a critical component of seismic resistant buildings, as evidenced by the collapse of the CTV Building, which caused over 60% of the fatalities in Christchurch on 22 February 2011.

Unfortunately, in New Zealand many diaphragms have received little, if any, proper analysis, design and detailing, and this deficiency continues despite the CTV Building collapse.

In many instances, the very concept of the proposed diaphragm, and the layout of the vertical lateral load resisting elements, does not form a rational seismic resistant system.

It is essential that rational diaphragms and layouts of lateral load resisting elements are determined at the earliest stages in the architectural planning of a building, and that the fundamental principles of engineering such as equilibrium, positive load paths, resistance to buckling and proper detailing of reinforced concrete connections are applied to diaphragms in all instances.

Despite the apparent simplicity of diaphragms, accurately determining the loads and the resulting distribution of internal forces acting on them can be difficult and time consuming.

There are three main types of seismic diaphragm action – ‘inertial,’ ‘transfer’ and ‘compatibility.’ Inertial loading is the direct horizontal seismic acceleration onto the floor. Research on the accelerations on individual floors is limited, and guidance in the form of ‘parts and portions’ and other provisions in loading standards can be too conservative or unconservative, depending on the position of the floor. Care must be exercised when determining which guidance to follow. Transfer forces acting where there are significant changes in floor layout and the stiffness of lateral load resisting elements between floors can be relatively straightforward to determine, but very large in size and difficult to design for. Compatibility forces within diaphragms caused as incompatible lateral load resisting elements such as shear walls and moment frames ‘fight’ each other can be very difficult to determine, and can be of large

magnitude.

The inevitable presence of lift, stair and service penetrations in floor slabs has meant that even apparently simple diaphragms should be analysed using relatively time consuming Strut and Tie (S&T) methods, until now. The Strut and Tie method requires the creation of a separate model for each load case. Therefore, in general, multiple models must be developed and solved for each diaphragm, and often additional preliminary analyses are required to determine an appropriate S&T model for each load case.

The Truss Method allows the use of a single model to analyse and design a diaphragm for all lateral load cases.

## REFERENCES

- Standards New Zealand (2006). “NZS3101:2006–Concrete Structures Standard”. Standards New Zealand, Wellington, NZ.
- Standards New Zealand (1997). “NZS3404:1997–Steel Structures Standard”. Standards New Zealand, Wellington, NZ.
- Bull DK (2004). “Understanding the Complexities of Designing Diaphragms in Buildings for Earthquakes”. *Bulletin of the New Zealand Society for Earthquake Engineering*, 37(2): 70-88.
- Moehle J, Hooper J, Kelly D and Meyer T (2010). “NEHRP Seismic Design Technical Brief No. 3 – Seismic Design of Cast-in-Place Concrete Diaphragms, Chords and Collectors”. National Institute of Standards and Technology, MD, USA.
- Sabelli R, Sabol T and Easterling W (2011). “NEHRP Seismic Design Technical Brief No. 5 – Seismic Design of Composite Steel Deck and Concrete-filled Diaphragms”. National Institute of Standards and Technology, MD, USA.
- Cowie K, Hicks S, MacRae G, Clifton GC and Fussell A (2013). “Seismic Design of Composite Metal Deck and Concrete Filled Diaphragms – A Discussion Paper”. *Steel Innovations Conference, Christchurch, NZ*, Paper 24.
- Cowie KA, Fussell AJ, Clifton GC, MacRae GA and Hicks SJ (2014). “Seismic Design of Composite Metal Deck and Concrete-Filled Diaphragm – A Discussion Paper”. *NZSEE Annual Conference, Auckland, NZ*.
- Uma SR, Zhao JX and King AW (2009). “Floor Response Spectra for Ultimate and Serviceability Limit States of Earthquakes”. *NZSEE Annual Conference, Christchurch, NZ*.
- Scarry JM (2002). “An Open Letter to IPENZ on the Parlous State of the Structural Engineering Profession and the Construction Industry in New Zealand”. First Version.
- Scarry JM (2002). “An Open Letter to IPENZ on the Parlous State of the Structural Engineering Profession and the Construction Industry in New Zealand”. Second Version
- CSI. “ETABS – A Finite Element Structural Analysis Program for Buildings”. Computers and Structures Inc, CA, USA.
- Standards New Zealand (2004). “NZS1170.5:2004 – Structural Design Actions, Part 5: Earthquake Actions – New Zealand”. Standards New Zealand, Wellington.
- Gardiner DR, Bull DK and Carr AJ (2008). “Internal Forces of Concrete Floor Diaphragms in Multi-Storey Buildings”. *NZSEE Annual Conference, Wairakei, NZ*.
- Paulay T and Priestley MJN (1992). “*Seismic Design of Reinforced Concrete and Masonry Buildings*”. John Wiley & Sons.
- Wyllie LA and LaPlante RW (2003). “*The Designer’s Responsibility for Rebar Design*”. Concrete Reinforcing Steel Institute, IL, USA.
- Carr AJ. “*Ruaumoko – Program for the time history analysis of non-linear two-dimensional structures*”. University of Canterbury, Christchurch, NZ.
- Carr AJ. “*Ruaumoko 3D – Program for the Time History Analysis of Non-linear Three-dimensional Structures*”. University of Canterbury, Christchurch, NZ.
- Gardiner DR (2011). “*Design Recommendations and Methods for Reinforced Concrete Floor Diaphragms Subjected to Seismic Forces*”. PhD Thesis, University of Canterbury, Christchurch, NZ.
- Engineering Systems. “*Microstran Version 9 – A general Structural Analysis Program for Frame and Truss Structures*”. Engineering Systems Pty Ltd, USA.
- Integrated Technical Software. “*SpaceGass Version 11 – A General Structural Analysis Program for Frame and Truss Structures*”. Integrated Technical Software Pty Ltd, USA.
- Reineck KH (2002). “*SP-208 Examples for the Design of Structural Concrete with Strut and Tie Models*”. American Concrete Institute, MI, USA.
- CSI. “*SAP2000 Advanced/Ultimate – A General Finite Element Structural Analysis Program incorporating Non-linear Material Behaviour*”. Computers and Structures, Inc, CA, USA.

## APPENDIX A – USING FORCES DERIVED FROM A 3D ANALYSIS AS ‘SUPPORTS’

Assume the floor shown in Figure 19 is one of several similar floors in a multi-level building. A 3D ETABS analysis of the building has been carried out. In the ETABS model, the shear walls provide all of the lateral resistance, and infinitely rigid diaphragms were applied at each floor. For simplicity, there are four load cases (E+X, E-X, E+Y, E-Y), just as in the example above.

Consider load case E+Y, and assume that for the floor diaphragm that is to be analysed the inertial floor load and ‘reactions’ from the shear walls are as shown in Figure 24. (These are the same as in one of the examples presented in the paper, to allow comparison of the results).

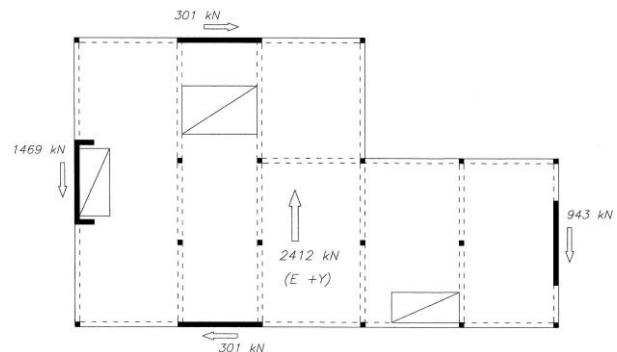

Figure 24: Diaphragm example - overall reactions – load case E+Y.

The loads and reactions are in equilibrium, but these cannot all be simply entered as forces in a 2D truss model without

supports – the model would not be stable, and the analysis would be terminated. Bearing in mind that the shear walls connect to the truss diaphragm over several nodes, and each ‘reaction’ will be distributed between those nodes, the way to create a useful model is to delete two of the reaction forces, and in their place, install some ‘simple supports.’ Equilibrium will ensure that the ‘simple support’ reactions will equal the missing ‘reactions’ from the 3D analysis. Only one arrangement of simple supports is required – the truss model with two simple supports used in the example below worked for all four load cases.

In Figure 25, two simple supports have been applied to the truss model. The 301 kN ‘reactions’ from the top and bottom walls have been applied as four nodal forces of 75.25 kN.

On the LHS, no ‘reaction’ force has been applied. On the RHS,  $\frac{3}{4}$  of the 943 kN reaction has been applied to three of the four nodes connected to the shear wall. The inertial load of 2412 kN was distributed to each node, in the same way as it was in the example above.

When the 2D truss model is analysed, the X direction reaction at the LHS support is zero, as it should be, and the Y direction reaction equals 1469 kN, exactly the same as the ‘deleted’ reaction from the 3D analysis. The Y direction reaction at the RHS support is 236 kN, which equals the missing part of the reaction force.

Figure 26 shows the truss actions at the RHS end of the diaphragm. They are almost identical to those shown in Figure 22.

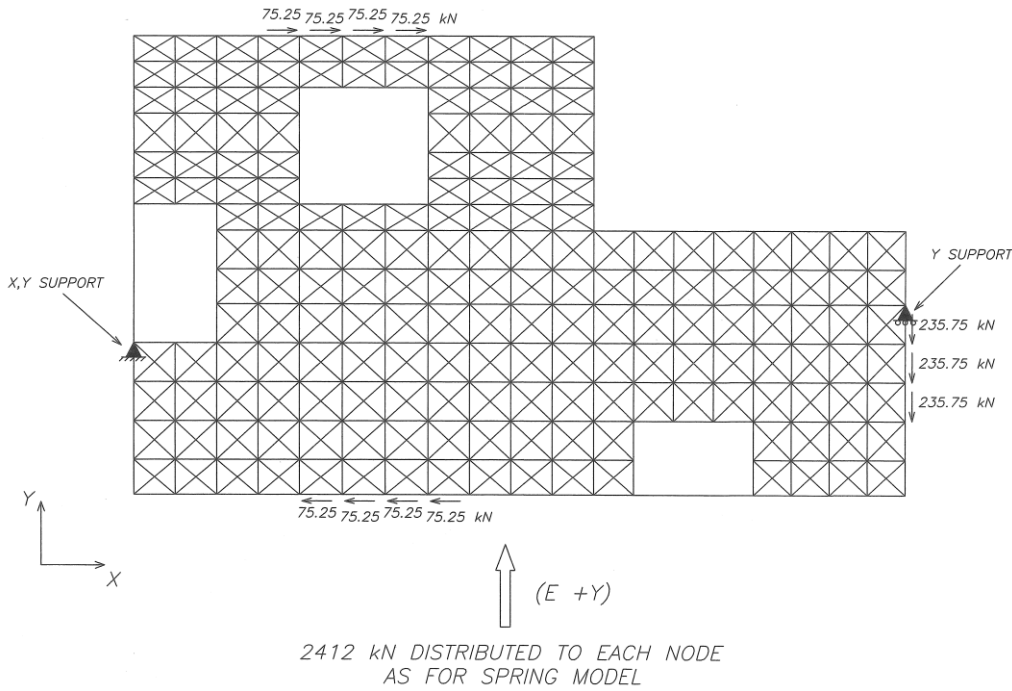

Figure 25: Diaphragm example - alternate truss model with reactions as ‘supports’.

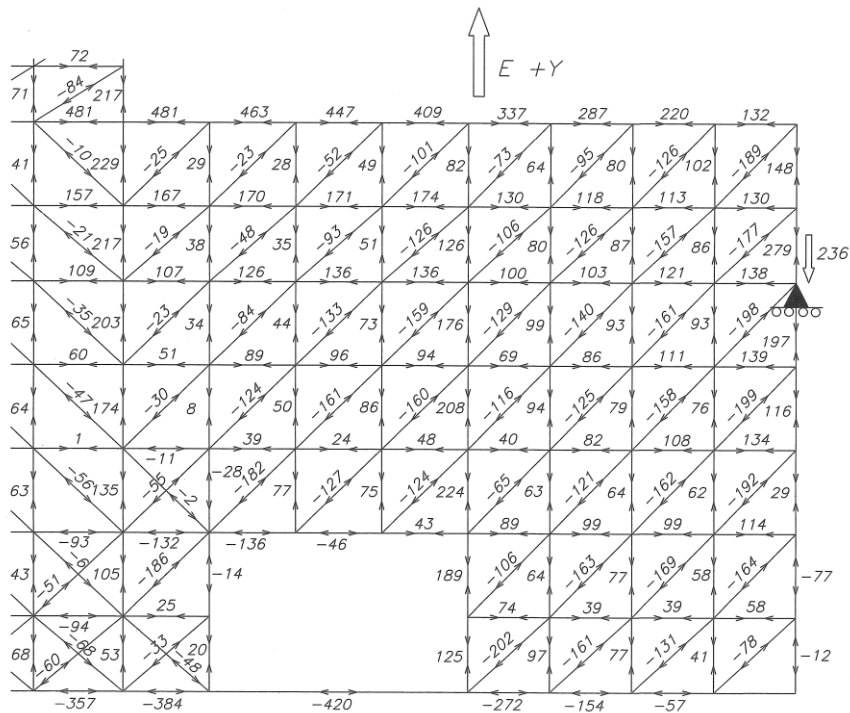

Figure 26: Diaphragm example - alternate truss model - S&T forces at RHS - load case E+Y.