



Product catalogue

Submersible drainage pumps SX, 50 Hz



Flygt



ITT Industries
Engineered for life



Introduction

The SX range is a compact high performance range of submersible pumps in stainless steel. The pumps can handle suspended solids up to 20 mm, depending on pump size.

- Delivery: up to 410 l/min
- Head: up to 21 m

Applications

- Routine and general maintenance of basements
- Drainage of underpasses and yards, tanks and reservoirs, ditches and trenches
- Removal of waste water from washing machines and washing stations
- Transfer of raw water
- Transfer of clean or contaminated water
- Emergency drainage in case of flooding
- Fountains

Product identity

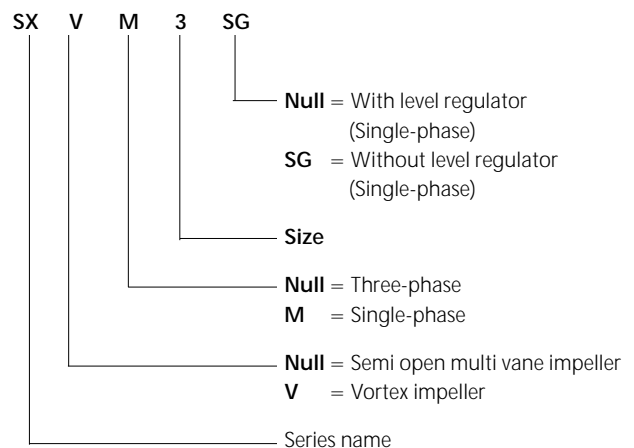



SX 2, SX 3, SXV 3

Product

Submersible stainless steel pump suitable for a variety of drainage applications.

Process data

Liquid temperature	max 40°C
Max size of suspended solids:	
SX 2, 3	10 mm
SXV 3	20 mm

Motor data

Dry motor for submersible duty. Single-phase motor has built in capacitor.	
Frequency	50 Hz
Insulation class	B (125°C)
Protection	IP68
Immersion depth	max 5 m

Cable

H07RN-F	10 m
---------	------

Control

Single-phase	Built in level regulator
Three-phase	To be provided

Performance curves

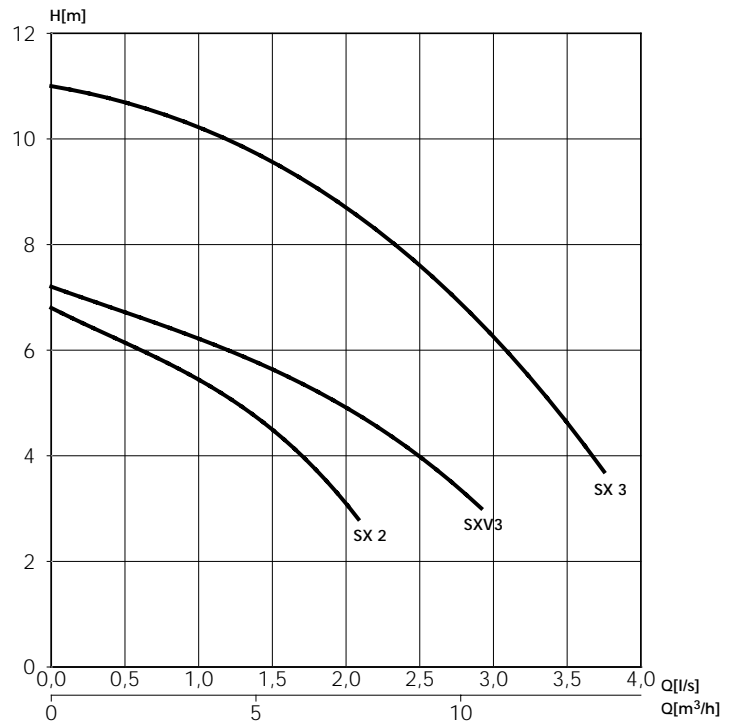

Design

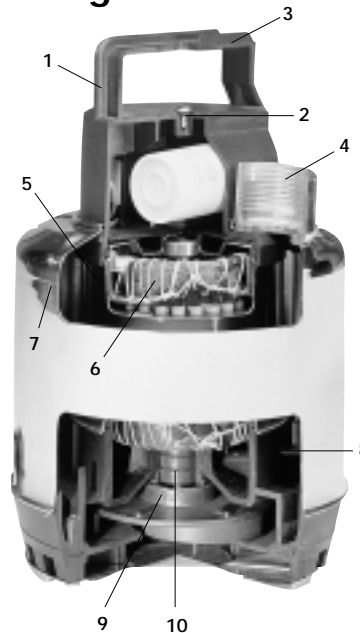

1. Lifting handle, fiberglass-reinforced noryl.
2. Testing hole to check hermetic seal of motor gaskets by compressed air.
3. Cable clamp for adjusting the float.
4. Delivery outlet.
5. Motor housing with enclosed upper bearing, seamless & stainless steel.*
6. Dry winding motor, class B windings.
7. External sleeve, one-piece, seamless and stainless steel.*
8. Pump body, fiberglass-reinforced noryl.
9. Triple lip seal.
10. Shaft, stainless steel.*

*AISI 304–DIN 1.4301

Motor rating

Pump type	Power kW	Capacitor		Input current A	
		µF	V	Single-phase 230 V	Three-phase 380-415 V
SXM 2	0.25	6	450	1.5	
SXM 3	0.55	16	450	3.7	1.4
SXVM 3	0.55	16	450	3.7	1.4

Dimensions and weight

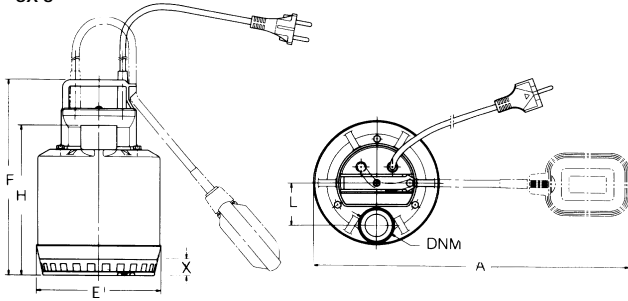
 SX 2
 SX 3

SX V3

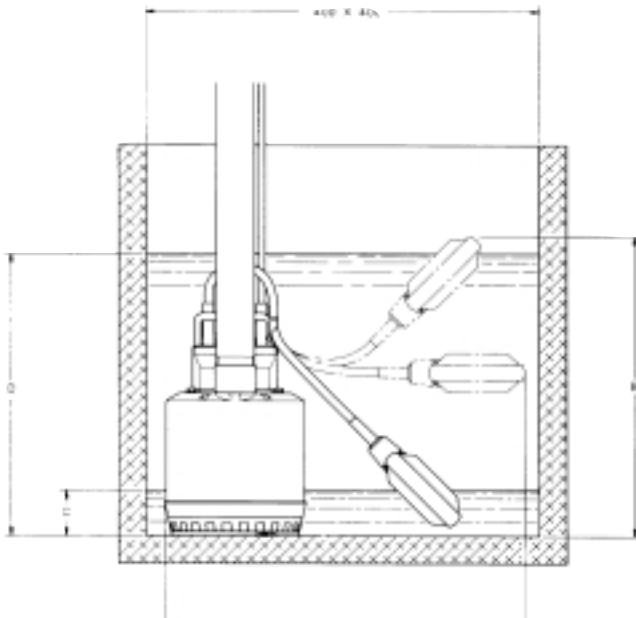
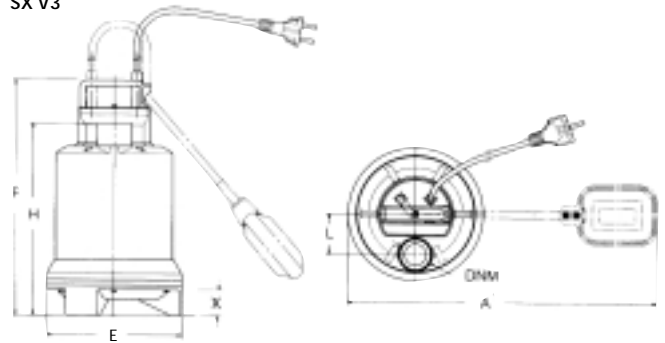

Pump type	Dimensions in mm									DNM	Weight kg
	A	B	C Stop level	D Start level	E	F	H	L	X		
SXM 2	390	330	50	310	155	245	188	54	20	G 1"1/4	4
SXM 3	390	370	90	350	155	285	228	54	20	G 1"1/4	6
SXVM 3	390	395	115	375	175	310	252	54	50	G 1"1/4	6
SX 2					155	245	188	54	20	G 1"1/4	4
SX 3					155	285	228	54	20	G 1"1/4	6
SXV 3					175	310	252	54	50	G 1"1/4	6

Accessories

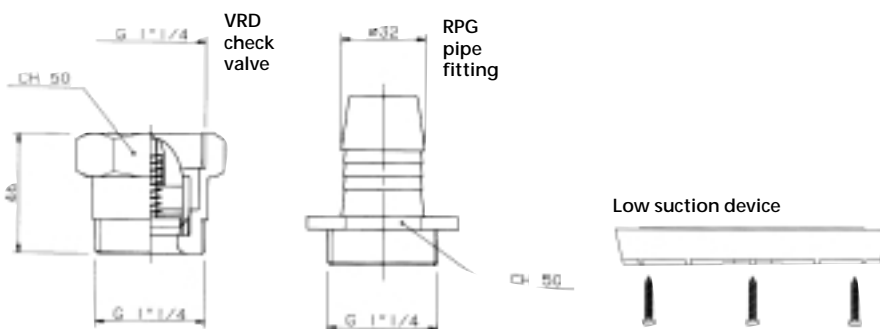



Design

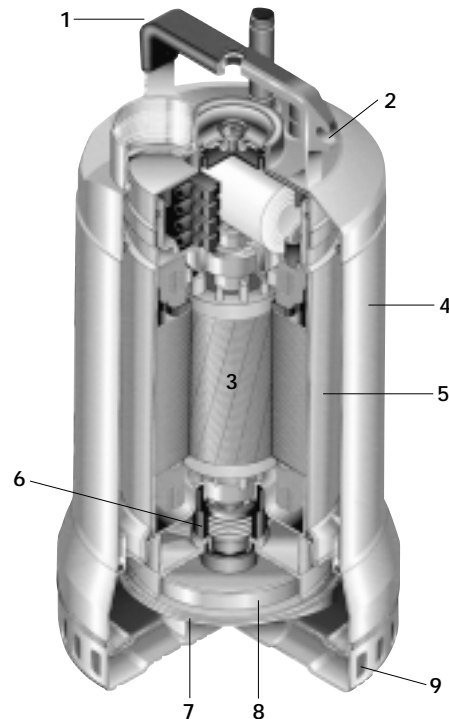

SX 5, 7, 11, 15

Product

Submersible stainless steel pump suitable for a variety of drainage applications.

Process data

Liquid temperature max 50°C
 Max size of suspended solids: 8 mm

Motor data

Dry motor for submersible duty. Single-phase motor has built in capacitor, except SX 11, which has the control box on the cable.

Frequency 50 Hz
 Insulation class F(155°C)
 Protection IP68
 Max immersion depth 7 m

Cable

H07RN-F 10 m

Control

Single-phase Built in level regulator
 Three-phase To be provided

1. Lifting handle, stainless steel*, coated with polyacetal resin.
2. Cable clamp for adjusting the float.
3. Dry winding motor, class F windings.
4. Cooling jacket, stainless steel.*
5. Motor casing and pump body, stainless steel.*
6. Sealing system, double seal with oil chamber.
7. Impeller, open type in stainless steel.*
8. Diffuser plate, stainless steel* coated with polyurethane.
9. Strainer, minimum liquid level 25 mm, suspended solids up to 8 mm.

* AISI 304-DIN 1.4301

Motor rating

Pump type		Capacitor			Input current	
Single-phase 220-240 V	Three-phase 220-240 V 380-415 V	kW	µF	V	Single-phase 220-240 V	Three-phase 380-415 V
SXM 5	SX5	0.55	16	450	3.4	1.35
SXM 7	SX 7	0.75	22	450	5.1	2.1
SXM 11	SX11	1.1	30	450	6.7	2.6
	SX15	1.5				3.7

Performance curve

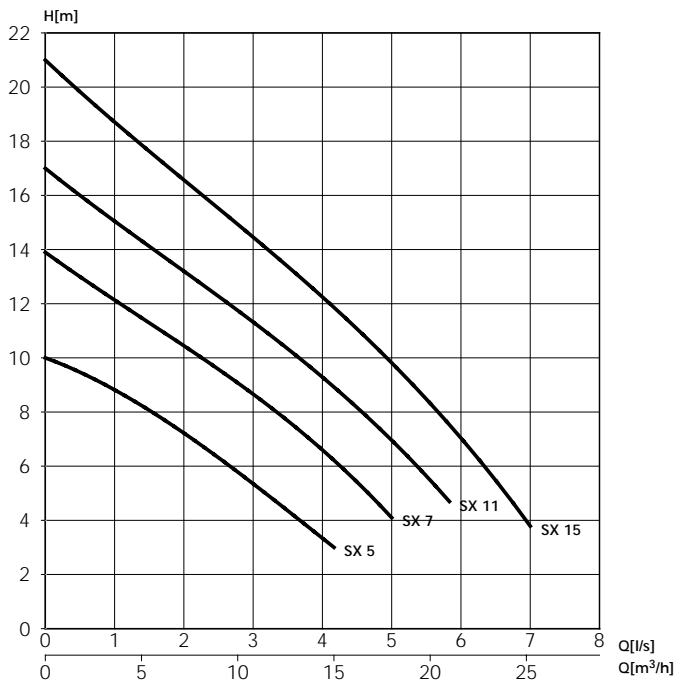

Dimensions and weight

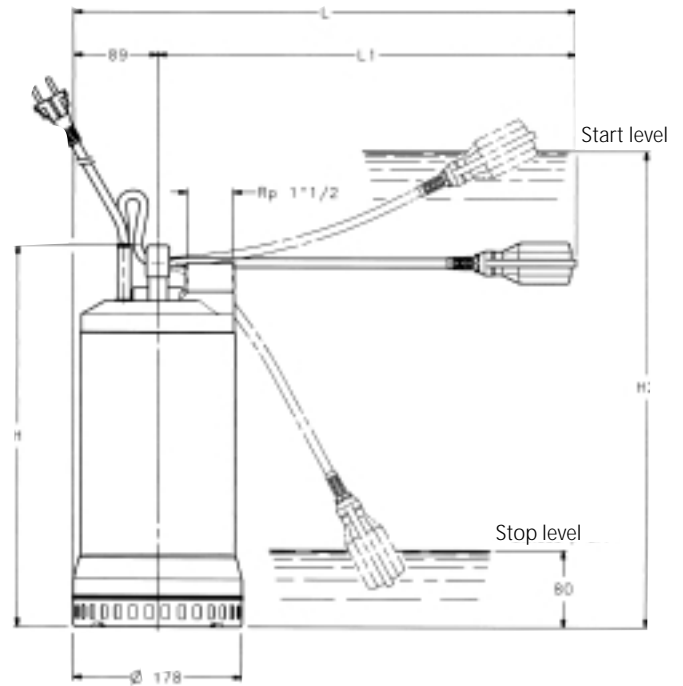

Pump type	Dimensions in mm				Weight kg
	H	H2	L	L1	
SXM 5	343	425	459	370	12
SXM 7	388	485	514	425	14.5
SXM 11	388	485	514	425	17
SX 5	343				11
SX 7	358				13
SX 11	388				15
SX 15	388				16.5