

**SLV EURO SPOT spot for 1-phase high-voltage bus bar**  
QPAR51, white, max. 25W, incl. 1-phase adapter

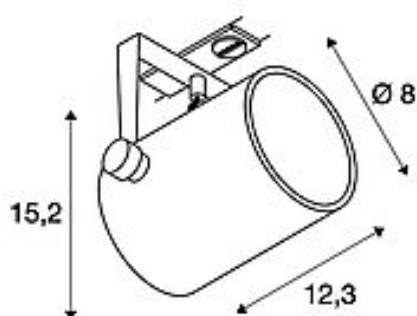

Article number	143811
Product family	EURO SPOT QPAR51
Feed-in capability	No
Lampholder / Socket	GU10
Number of light sources	1
Lamp included	No
Tilt range	90 Degree
Rotation range	350 Degree
Length	12.5 cm
Height	16 cm
Diameter	8 cm
Net weight	0.481 kg
Gross weight	0.619 kg
Voltage	230V ~50Hz
Max. wattage	25 Watt
Protection class	I
Energy efficiency class	A++
Way of mounting	Surface mounted / Ceiling track / Wall track
Lamp	QPAR51
Colour	white
Form	cylindric
Light distribution type 1	direct
Material	Aluminium/glass

#### Articles of this series

- 
- |        |                                                                                             |
|--------|---------------------------------------------------------------------------------------------|
| 143814 | EURO SPOT spot for 240V 1-phase track, QPAR51, silver-grey, max. 25W, incl. 1-phase adapter |
|--------|---------------------------------------------------------------------------------------------|
- 
- |        |                                                                                        |
|--------|----------------------------------------------------------------------------------------|
| 153850 | EURO SPOT, spot for 240V 3-phase track, QPAR51, black, max. 25W, incl. 3-phase adapter |
|--------|----------------------------------------------------------------------------------------|
- 
- |        |                                                                                        |
|--------|----------------------------------------------------------------------------------------|
| 153851 | EURO SPOT, spot for 240V 3-phase track, QPAR51, white, max. 25W, incl. 3-phase adapter |
|--------|----------------------------------------------------------------------------------------|
- 
- |        |                                                                                              |
|--------|----------------------------------------------------------------------------------------------|
| 153854 | EURO SPOT, spot for 240V 3-phase track, QPAR51, silver-grey, max. 25W, incl. 3-phase adapter |
|--------|----------------------------------------------------------------------------------------------|

Adjustable high-voltage spot EURO SPOT with suitable adapter for the 240V 1-phase track system. Thanks to the GU10 socket installed in the cylindrical aluminium lamp head, the luminaire is suitable for halogen and LED lamps with a diameter of up to 5cm. This luminaire is suitable for lamps of energy classes: E - A++

#### Notes

---

---

---