



VR (STR-1)

The STR-1 transformer speed controllers are based on the principle of voltage control with auto-transformers. They are applicable to voltage-controllable motors (230 V, 50/60 Hz) to control in steps the rotational speed (of fans, pumps, etc.).

When choosing a controller it is important to know the maximum current intensity consumption on the taps. The indicated maximum current can be taken from each tap.

Features

- < 230 Vac - 50/60 Hz - from 0,8 up to 20 A
- < Enclosure: plastic (R-ABS, UL94-V0, grey RAL 7035) or sheet steel (RAL 7032, polyester powder coating)
- < IP54
- < Switch: 5 positions with Off-position
- < Several voltage ranges possible
- < Indicator light
- < Current fuse
- < 230 Vac, unregulated output
- < Ready mounted cable glands
- < Maximal ambient temperature: 35 °C

	Imax (A)	Fuse (A)
STR-1-10L10	1,0	(5*20 mm) 1,25
STR-1-08L22	0,8	(5*20 mm) 1,5
STR-1-15L22	1,5	2,0
STR-1-22L22	2,2	3,15
STR-1-35L22	3,5	5,0
STR-1-50L22	5,0	8,0
STR-1-75L22	7,5	10,0
STR-1100L22	10,0	(6*32 mm) 16,0
STR-1130L22	13,0	20,0
STR-1160L20	16,0	25,0
STR-1200L20	20,0	30,0

Wiring diagram

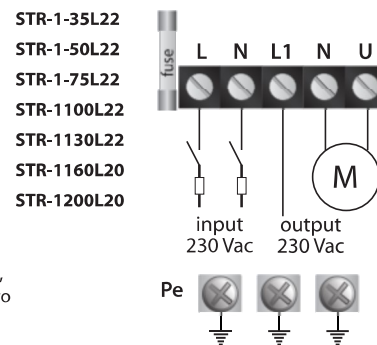
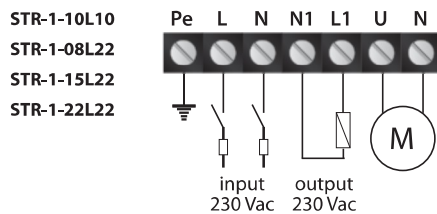

Type L22: by exchanging the fastonclip connectors on the transformer, one can adjust the order of switching and the voltage corresponding to each step of the switch.

Dimensions & fixing

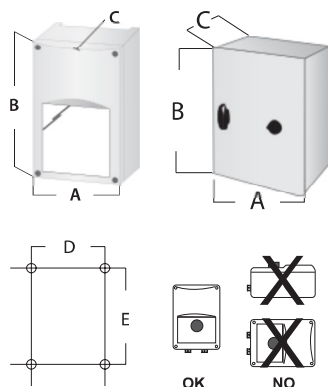

	A	B	C	D	E	net weight	gross weight	enclosure
STR-1-10L10	84	160	88	71	108	1,0 kg	1,1 kg	plastic
STR-1-08L22	115	205	100	98	140	1,6 kg	1,6 kg	plastic
STR-1-15L22	115	205	100	98	140	2,1 kg	2,1 kg	plastic
STR-1-22L22	115	205	100	98	140	4,3 kg	4,3 kg	plastic
STR-1-35L22	170	255	140	155	194	4,7 kg		plastic
STR-1-50L22	170	255	140	155	194	5,0 kg		plastic
STR-1-75L22	200	305	140	183	236	7,8 kg	7,9 kg	plastic
STR-1100L22	300	325	185	255	255	12,9 kg		steel
STR-1130L22	300	325	185	255	255	15,0 kg	15,1 kg	steel
STR-1160L20	300	425	235	255	355	18,4 kg		steel
STR-1200L20	300	430	235	255	355	21,0 kg		steel